

7558541/2023/EEMRT-ENE51

NOTE: 1. DRAWING APPROVAL SUBJECT TO VALID TYPE TEST
REPORTS, TO BE CHECKED DURING ACCEPTANCE TESTS
2. FOR EPC CONTRACTS ONLY



GREEN SECURE ENERGY SYSTEMS

Drawing approval subject to valid vendor registration

DOCUMENT:	STANDARD DRAWING
OWNER:	M/s. AP TRANSCO
PRODUCT:	BATTERY CHARGER WITH DCDB
CHARGER RATING:	220V DC / 200AH, 22A FC & 25A FCBC BATTERY CHARGER

**Chief Engineer/Projects
APTRANSCO/VS/Vijayawada.**

2. FOR EPC CONTRACTS ONLY



GREEN SECURE ENERGY SYSTEMS

BATTERY CHARGER PANEL

This Battery charger is designed to feed the load & to charge the battery both continuously with rated current at rated voltage. This is floor mounting freestanding type cabinet made of CRCA sheet with 2.5mm load bearings and 2mm non-load bearing and removable side doors. The heavy components like transformers, chokes are mounted at the backside on channel platform. Natural air cooling (Exhaust fans are mounted to forcibly cool the power devices, transformers, and others if the cooling fans fails it doesn't affect the system), All the other components will be mounted on a component plate and Mounting channel to the possible extent. The control Switches, Meters, Indicating Lamp, annunciator are mounted on front door with legends. Bottom gland plate is provided to take all connections from the bottom TB. The panel will have louvers for good ventilation. The panel will be chemically treated before it is painted by powder coating of shade 631 of IS-5.

The Float and Float cum Boost Charger will be connected to AC input power through individual circuit breaker CB-101/102. The transformer TRF1/TRF7 step down the AC input to the required level and this AC power is fed to the respective power bridge (SCR (TH1-TH3/TH4-TH6)). The transformer (Tfr-2 & 8) has winding of 20V for supplying power to control circuit and (Tfr-3-6 & 9-12)24V for triggering circuit. The overall system is protected against overload and short circuit by fuses, circuit breakers, contactors with thermal overload relays OLR1 & OLR2. The Charger control & triggering PCB-1 and Control & triggering PCB-2 provide the regulation and current limit to the Charger circuit, in addition to supplying gate pulses to the power SCRs. The output voltage of Float Charger, independent of AUTO/Manual selection, is adjusted by using the potentiometer P1. The output Float voltage of FCBC in VRLA mode can be adjusted independent of AUTO/Manual selection is adjusted by using Potentiometer P2. The output Boost Voltage of FCBC in VRLA mode can be adjusted independent of AUTO/Manual selection is adjusted by using the Potentiometer P3. For NVRLA mode, float voltage of FCBC can be adjusted by using Potentiometer P4 (In NVRLA mode FCBC works only in Manual Mode). For NVRLA mode, Boost voltage of FCBC can be adjusted by varying potentiometer P5 (In NVRLA mode FCBC works only in Manual Mode). Equalizing voltage in NVRLA can be adjusted by varying P6. Potentiometer P7 (FCBC) is used to increase or decrease current setting of the Battery current Limit circuit. NVRLA & Auto mode are selected charger should work in Float mode.

The potentiometers provided externally (P1, P2, P3, P4, P5) work in parallel with the Internal Potentiometers provided on the PCB s. Hence, the Internal and external Potentiometers act as a combined unit and so, any change in the settings of either the external Potentiometers (P1, P2, P3, P4, and P5) or the internal Potentiometers mounted on the PCBs will cause change in the Set Voltage values.

The DC power is filtered and smoothened using filter chokes L-11 & L-21 and DC capacitors Bank FC1/FC2. Normally the charger will charge the battery in constant current mode when battery is highly discharged. Once the battery is charged then it will be charging in constant voltage mode. While charging in constant voltage mode charger will be supplying trickle current to meet the leakage current and any loads connected to the battery.

Drawing approval subject to valid vendor registration

Important points:

1. The float charger (FC) has an internal Charging Voltage setting and the charging voltage is decided by the external Potentiometer P1 only, irrespective of the position of selector switches SW1, SW2.
2. The Float charger has an internal current setting of 12 Amps DC for battery current (set by potentiometer VR8 on card GSSCB02B-1 which when rotated in clockwise fashion increases the set value and vice versa)

2. FOR EPC CONTRACTS ONLY

**GREEN SECURE ENERGY SYSTEMS**

which acts as a Pickup current beyond which, the FCBC will start automatically in Boost mode and feed the battery, while the Float charger keeps feeding the load.

3. The FCBC has two internal Charging Voltage settings for AUTO mode only. One for VRLA Float and the other for VRLA boost. These charging voltage settings are decided by the internal Potentiometer VR1 for VRLA Float and Potentiometer VR4 for VRLA Boost. This makes the charger operation not possible for NVRLA battery in AUTO mode. NVRLA battery can be charged in Manual mode only.

4. The FCBC has an internal current setting which acts as a Drop Off current Set Value, below which the FCBC switches off the Boost voltage. This setting (battery current /Float charger output current drop off value) is set at 6 Amps DC by potentiometer VR11 on card GSSCB02B-2. The set value can be increased by turning the pot in clockwise fashion and vice versa.

Auto Operation

For AUTO operation of the charger, the AUTO/MANUAL FLOAT/MANUAL BOOST selector switch (SW2) must be kept in AUTO position.

When the selector switch SW2 is in AUTO mode, the Float charger works in float mode and will feed the Loads as well as the battery through the K3 contactor which shall be in closed condition as per the internal logic of the control card of the float charger. But if the Battery charging current exceeds 12 amps the Following actions take place.

1. K3 contactor will drop and simultaneously, the FCBC will start charging the Battery in the boost mode automatically and will improve the battery voltage.
2. The Float charger continues to feed the Loads at Float voltage.
3. When K3 is OFF, if the Mains supply fails, a permanent connection of Tap Cell to the load is provided to prevent loss of DC voltage to loads.
4. As soon as the battery charging current falls below a preset value of 6 amps the FCBC will stop its action, the K3 contactor will pick up again and the battery and load will be fed from the Float Charger (FC) and normalcy will be restored.
5. In the AUTO mode, if the Float charger becomes faulty, the FCBC will act as a Float charger only and will feed the Loads and the battery.
6. Similarly, in AUTO mode, if the FCBC becomes faulty, the Float charger will work in FLOAT mode and will feed the load and battery.

Drawing approval subject to valid vendor registration

Manual Mode

The charger has a selector switch SW1 by which either VRLA mode or NVRLA mode can be selected. Once this switch is selected in either VRLA mode or NVRLA mode, the next step is to select either AUTO mode or Manual Float mode or Manual Boost mode.

If the Manual Float mode is selected in SW2 and SW1 is selected in VRLA, the Potentiometer P2 will decide the set voltage. If SW2 is in Manual Boost mode and SW1 is in VRLA, Potentiometer P3 will decide the set voltage. If the Manual Float mode is selected in SW2 and SW1 is selected in NVRLA, the Potentiometer P4 will decide the set voltage. If the Manual Boost mode is selected in SW2 and SW1 is selected in NVRLA, the

75585 11/2023/EEMRT-ENCL-01, TO BE CHECKED DURING ACCEPTANCE TESTS

2. FOR EPC CONTRACTS ONLY



GREEN SECURE ENERGY SYSTEMS

Potentiometer P5 will decide the set voltage. If the Manual Equalize Mode is selected in SW2 and SW1 is selected in NVRLA, the Potentiometer P6 will decide the set voltage.

INTERLOCKING CONTACTOR (K3) OPERATION:

When the selector switch SW2 is in auto position, Provision is made to close the K3 for various condition of operation. The contactor operates on battery through potential free contact of FC & FCBC output voltage

sensing boards GSS-0718-1D and GSS-0718-2D relay board FFR-1/FFR-2. The precautions are taken for the following conditions.

- a. In case of mains power supply failure or any system abnormality signals received through GSS-0718-1D/2D, FFR-1/FFR-2 relays, the contactor K3 is energized, and it is ensured that the Load Bus is fed from the Battery.
- b. In Float cum boost charger, if SF4-SF6 is blown or charger fails (when the battery is fed from float cum boost charger FCBC), the contactor K3 closes through FCBC output relay sensing board FFR-1 & 2 so that the battery is connected to float charger.
- c. If float Charger or Float cum Boost charger failed, then also the contactor K3 is closed and providing full battery voltage to load.
- d. If float charger fails, then the Float cum Boost Charger should come in to Float mode automatically (whatever may be the mode selector switch position of SW1 & SW2) and supplies Load requirement by closing the contactor K3.

Logic matrix for FC & FCBC operations (For VRLA mode)

Condition of AC Supply	Mode	Condition of FC	Condition of FCBC	Battery Current	Interlocking contactor-K3	Load	Battery
AC supply available	Auto	Healthy	Healthy	Less than set value	ON	Supplied by FC (On float voltage)	On float voltage (By FC)
AC supply available	Auto	Healthy	Healthy	Greater than set value	OFF	Supplied by FC (On float voltage)	On boost voltage (by FCBC)
AC supply available	Auto	Fail	Healthy	Less/greater than set value	ON	Supplied by FCBC (On float voltage)	On float voltage (By FCBC)
AC supply available	Auto	Healthy	Fail	Less/greater than set value	ON	Supplied by FC (On float voltage)	On float voltage (By FC)
AC supply available	Manual float	Healthy	Healthy	Less/greater than set value	ON	Supplied by FCBC (On float voltage) and FC should be automatically off	On float voltage (By FCBC)
AC supply available	Manual boost	Healthy	Healthy	Less/greater than set value	OFF	Supplied by FC (On float voltage)	On boost voltage (by FCBC)
AC supply available	Manual float/boost	Fail	Healthy	Less/greater than set value	ON	Supplied by FCBC (On float voltage)	On float voltage (By FCBC)
AC supply available	Manual float/boost	Healthy	Fail	Less/greater than set value	ON	Supplied by FC (On float voltage)	On float voltage (By FC)
AC supply available	Any mode	Fail	Fail	Less/greater than set value	ON	Supplied by battery	On discharge
AC supply fail	Any mode	Healthy	Healthy	Less/greater than set value	ON	Supplied by battery	On discharge

NOTE: 1. DRAWING APPROVAL SUBJECT TO VALID TYPE TEST

75585/11/2023/EEMRT-ENR54 REPORTS, TO BE CHECKED DURING ACCEPTANCE TESTS

2. FOR EPC CONTRACTS ONLY

**GREEN SECURE ENERGY SYSTEMS****Logic matrix for FC & FCBC operations (For Tubular mode)**

Condition of AC Supply	Mode	Condition of FC	Condition of FCBC	Interlocking contactor-K3	Load	Battery
AC supply available	Manual float	Healthy	Healthy	OFF	Supplied by FC (On float voltage)	On float voltage (By FCBC)
AC supply available	Manual float	Healthy	Fail	ON	Supplied by FC (On float voltage)	On float voltage (By FC)
AC supply available	Manual float	Fail	Healthy	ON	Supplied by FCBC (On float voltage)	On float voltage (By FCBC)
AC supply available	Manual boost	Healthy	Healthy	OFF	Supplied by FC (On float voltage)	On boost voltage (by FCBC)
AC supply available	Manual boost	Healthy	Fail	ON	Supplied by FC (On float voltage)	On float voltage (By FC)
AC supply available	Manual boost	Fail	Healthy	ON	Supplied by FCBC (On float voltage)	On float voltage (By FCBC)
AC supply available	Any Mode	Fail	Fail	ON	Supplied by battery	On discharge
AC supply fail	Any Mode	Healthy	Healthy	ON	Supplied by battery	On discharge

No auto mode selection for a NVRLA battery.

Chief Engineer/Projects
APTRANSCO/VS/Vijayawada.

Drawing approval subject to valid vendor registration

NOTE: 1. DRAWING APPROVAL SUBJECT TO VALID TYPE TEST

735854172023/REPORTS/NO.01 CHECKED DURING ACCEPTANCE TESTS

2. FOR EPC CONTRACTS ONLY



GREEN SECURE ENERGY SYSTEMS

TECHNICAL SPECIFICATION

Type : FLOAT & FLOAT CUM BOOST CHARGER
Rating : 220V 22A FC & 25A FCBC with DCDB and battery bank.
Technology : Thyristor based technology, for 220V/200Ah VRLA/NVRLA

AC INPUT :

1. Voltage : 415VAC $\pm 15\%$
 2. Frequency : 50Hz $\pm 5\%$
 3. Phase, Wires : 3 Phase, 4Wire
 4. Operating temperature: 0 $^{\circ}$ c to +50 $^{\circ}$ c

DC OUTPUT :

SL.NO	DESCRIPTION	VRLA	NVRLA
1	No. of cells	110	110
2	Float voltage	247.5V	247.5C
3	Boost voltage	253V	302.5V
4	Equalizing Voltage		302.5V
5	Charger output voltage	247.5V	247.5V
6	Charger output current - FC	22A	22A
7	Charger output current - FCBC	25A	25A
8	Ripple	Less than 2% RMS	
9	Efficiency	$\geq 85\%$ at full Load	
10	Voltage Regulation	$\pm 1\%$	

Drawing approval subject to valid vendor registration

Chief Engineer/Projects
APTRANSCO/VS/Vijayawada.

NOTE: 1. DRAWING APPROVAL SUBJECT TO VALID TYPE TEST

7358541/2023/EMP/PROJ/01 TO BE CHECKED DURING ACCEPTANCE TESTS

2. FOR EPC CONTRACTS ONLY



GREEN SECURE ENERGY SYSTEMS

METERS :

SLNO	Meter Description	Type	Class	Qty
1	AC VAF meter	Digital	1	1
2	FC VA METER	Digital	1	3
3	FCBC VA METER	Digital	1	1
4	BATTERY VA METER	Digital	1	1
5	LOAD VA METER	Digital	1	1
6	Earth Leakage Ammeter	Analog	0.5	1

INDICATIONS: Clustered LED will be provided for the following condition:

- | | |
|--------------------|-------------------------------|
| 1. L1-L3 | : Phase indicating lamp (RYB) |
| 2. L4 | : Float ON |
| 3. L5 | : Boost ON |
| 4. L6 | : K3(Contactor ON) |
| 5. DCDB & FDR 1-36 | : DCDB Incomer & Feeder ON |

ALARM ANNUNCIATOR WITH RS485 WILL BE PROVIDED FOR THE FOLLOWING CONDITIONS WITH AUDIO ALARM WITH PFCs FOR ABNORMALITIES:

- AC mains fail
- FC AC I/P Circuit Breaker Trip/Fail
- FCBC AC I/P Circuit Breaker Trip/Fail
- FC DC O/P Circuit Breaker Trip/Fail
- FCBC DC O/P Circuit Breaker Trip/Fail
- DC under voltage.
- DC over voltage.
- Battery earth fault.
- FC Rectifier/Thyristor Fuse Fail
- FCBC Rectifier/Thyristor Fuse Fail
- FC Filter/Capacitor Fuse Fail
- FCBC Filter/Capacitor Fuse Fail
- DC Contactor Off
- Battery I/P Circuit Breaker Trip/Off
- DC Fail
- Phase fail/Phase reversal.

Chief Engineer/Projects
APTRANSCO/VS/Vijayawada

Drawing approval subject to valid vendor registration

NOTE: 1. DRAWING APPROVAL SUBJECT TO VALID TYPE TEST REPORTS, TO BE CHECKED DURING ACCEPTANCE TESTS
2. FOR EPC CONTRACTS ONLY



GREEN SECURE ENERGY SYSTEMS

PROTECTION:

Following Protections will be provided in the system.

1. AC Input protection MCCB for both FC & FCBC
2. Protective Relay (Over / Under Voltage, Over / Under Frequency, Phase (Failure, Sequence)).
3. Battery current limiter.
4. Fuses & MCCBs for over load and short circuits (for both AC & DC).
5. DC Short Circuit Protection.
6. Relay protection for over voltage and under voltages for both FC & FCBC.
7. Galvanic isolation by transformer
8. DC output protection MCCB for both FC & FCBC
9. Fast acting semiconductor fuses for both FC & FCBC
10. Charger over load protection
11. MCCB for Battery input protection
12. Blocking diodes

Chief Engineer/Projects
APTRANSCO/VS/Vijayawada.

CONTROLS & SWITCHES:

1. Auto/float/boost mode selector switch
2. VRLA/NVRLA mode selector switch
3. Potentiometers & Selector switch for float/boost/equalizing voltage variations of $\pm 10\%$
4. MCB for Door lamp /Heater/ socket power supply
5. MCCB for AC input and DC output and also for battery

DCDB incomer	:	100A 3P MCCB
FEEDER1-12	:	20A 2P MCB
FEDDER13-36	:	10A 2P MCB
4-20mA Transducer for DC earth leakage – 1 No.		

7358741/2023/AMR/15151

NOTE: 1. DRAWING APPROVAL SUBJECT TO VALID TYPE TEST REPORTS, TO BE CHECKED DURING ACCEPTANCE TESTS
2. FOR EPC CONTRACTS ONLY



GREEN SECURE ENERGY SYSTEMS

SPECIAL FEATURES: The following features are provided in the system

1. Soft starting on DC side.
2. Class-F insulation with class –F temperature limits for all magnetic materials.
3. Charger and battery current limiting feature
4. Filters to reduce ripple.
5. Automatic Float to Boost changeover based
On current drawn by Battery.
6. Space Heaters and thermostat for
Temperature.

GENERAL:

- | | | |
|-----------------------------------|---|--|
| 1. Cabinet | : | Freestanding cabinet, floor mounting type. |
| 2. CRCA Sheet Thickness | : | 2.5 mm for load bearing sections. |
| | : | 2.0 mm for non-load bearing sections. |
| | : | 3.0 mm for cable gland plate. |
| 3. Cabinet Dimensions | : | As per G.A drawings enclosed. |
| 4. Cable entry | : | Bottom |
| 5. Paint | : | Interior/Exterior:631 of IS-5 |
| 6. Paint thickness | : | 80-120microns |
| 7. Protection | : | IP42 |
| 8. Temperature range of operation | : | 0-50°C |
| 9. Earth Bus Bar (Tinned Copper) | : | 25 x 3 Sq.mm. |
| 10. Input & output terminals | : | Screw & Stud type. |
| 11. Nature of Cooling | : | Natural Air Cooling. (If exhaust fan fails system
Doesn't get affected) |

* * *

Chief Engineer/Projects
APTRANSCO/VS/Vijayawada.

Drawing approval subject to valid vendor registration

7558541/2023/EEMRT-ENE51

NOTE: 1. DRAWING APPROVAL SUBJECT TO VALID TYPE TEST REPORTS, TO BE CHECKED DURING ACCEPTANCE TESTS
 2. FOR EPC CONTRACTS ONLY

TABLE OF CONTENTS

Drawing approval subject to valid vendor registration

SL NO.	DRAWING FILE.	SHEET NO.	REVISION DETAILS	
			R0	R1
1	TITLE PAGE.	01	21.06.2023	26.06.2023
2	TABLE OF CONTENTS.	02	21.06.2023	26.06.2023
3	GENERAL SPECIFICATION	03	21.06.2023	26.06.2023
4	SINGLE LINE DIAGRAM.	04	21.06.2023	26.06.2023
5	GENERAL ARRANGEMENT.	05	21.06.2023	26.06.2023
6	AC POWER CIRCUIT FOR FC & FCBC	06	21.06.2023	26.06.2023
7	DC CIRCUIT	07	21.06.2023	26.06.2023
8	METER CIRCUIT	08	21.06.2023	26.06.2023
9	FEEDER CIRCUIT	09	21.06.2023	26.06.2023
10	CONTROL & TRIGGER CIRCUIT	10	21.06.2023	26.06.2023
11	FUSE FAILURE RELAY CIRCUIT	11	21.06.2023	26.06.2023
12	ALARM ANNUNCIATOR	12	21.06.2023	26.06.2023
13	ALARM ANNUNCIATOR	13	21.06.2023	26.06.2023
14	PFC TERMINALS	14	21.06.2023	26.06.2023
15	TERMINAL BLOCK DETAILS	15	21.06.2023	26.06.2023
16	TERMINAL BLOCK DETAILS	16	21.06.2023	26.06.2023

**Chief Engineer/Projects
 APTRANSCO/VIS/Vijayawada**

ALL INFORMATION CONTAINED IN THIS DOCUMENT IS CONFIDENTIAL AND COPYRIGHT THEREOF IS RESERVED BY GREEN SECURE ENERGY SYSTEMS, THEY SHALL NOT BE USED FOR ANY PURPOSE OTHER THAN FOR WHICH THEY ARE SUPPLIED AND SHALL NOT BE COPIED OR REPRODUCED WITHOUT WRITTEN PERMISSION.

			OWNER	APTRANSCO	 GREEN SECURE ENERGY SYSTEMS,.	DRN	DP	SCALE	NTS
							CHD	DP	DATE
01	26.06.2023	STANDARD DRAWING			TITLE	APPD	RJR	SHEET NO.	
00	21.06.2023	STANDARD DRAWING						02 OF 16	
REV	DATE	MODIFICATIONS	ALL DIMENSIONS ARE IN MM UNLESS OTHERWISE SPECIFIED.			PAGE TYPE	TABLE OF CONTENTS		
							DRAWING No.	APT STD	REV. 01

7558541/2023/EEMRT-ENE51

ALL INFORMATION CONTAINED IN THIS DOCUMENT IS CONFIDENTIAL AND COPYRIGHT THEREOF IS RESERVED BY GREEN SECURE ENERGY SYSTEMS, THEY SHALL NOT BE USED FOR ANY PURPOSE OTHER THAN FOR WHICH THEY ARE SUPPLIED AND SHALL NOT BE COPIED OR REPRODUCED WITHOUT WRITTEN PERMISSION.

NOTE: 1. DRAWING APPROVAL SUBJECT TO VALID TYPE TEST REPORTS, TO BE CHECKED DURING ACCEPTANCE TESTS

2. FOR EPC CONTRACTS ONLY

	ROTARY SWITCH WITHOUT OFF		LIGHT EMITTING DIODE		SEMI CONDUCTOR FUSE
	ROTARY SWITCH WITH OFF		LIMIT SWITCH		SHUNT
	AC PLUG WITH SWITCH		MINIATURE CIRCUIT BREAKER	//	SINGLE PHASE
	BATTERY		MODULED CASE CIRCUIT BREAKER		SPACE HEATER
	CAPACITOR (NON POLARIZED)		'NORMALLY OPEN' CONTACT		TERMINAL BLOCK
	CHOKE		'NORMALLY CLOSE' CONTACT		THERMOSTAT
	CONTACTOR/RELAY COIL		'NORMALLY OPEN' PUSH BUTTON	///	THREE PHASE
	CURRENT TRANSFORMER		'NORMALLY CLOSE' PUSH BUTTON		THYRISTOR
	DIODE		ROTARY ON/OFF SWITCH		VARIABLE RESISTOR
	EARTH(GROUND)		ON/OFF TOGGLE SWITCH		SURGE PROTECTION DEVICE
	RESISTOR		OVER LOAD RELAY		
	ELECTROLYTIC CAPACITOR		PANEL ILLUMINATION LAMP		
	HRC FUSE LINK		POTENTIAL TRANSFORMER		
	GLASS FUSE		POTENTIOMETER		
	HRC FUSE		COOLING FAN		
	HOOTER				
	INDICATION LAMP				

**Chief Engineer/Projects
APTRANSCO/VS/Vijayawada.**

Drawing approval subject to valid vendor registration

			OWNER	APTRANSCO	GREEN SECURE ENERGY SYSTEMS,.			DRN	DP	SCALE	NTS	
								CHD	DP	DATE	26.06.2023	
01	26.06.2023	STANDARD DRAWING			TITLE	220VDC / 200Ah, 22A FC & 25A FCBC WITH DCDB			APPD	RJR	SHEET NO.	
00	21.06.2023	STANDARD DRAWING				PAGE TYPE	BASIC SYMBOLS			DRAWING No.		
REV	DATE	MODIFICATIONS	ALL DIMENSIONS ARE IN MM UNLESS OTHERWISE SPECIFIED.						APT STD	REV.	01	

ALL INFORMATION CONTAINED IN THIS DOCUMENT IS CONFIDENTIAL AND COPYRIGHT THEREOF IS RESERVED BY GREEN SECURE ENERGY SYSTEMS, THEY SHALL NOT BE USED FOR ANY PURPOSE OTHER THAN FOR WHICH THEY ARE SUPPLIED AND SHALL NOT BE COPIED OR REPRODUCED WITHOUT WRITTEN PERMISSION.

NOTE: 1. DRAWING APPROVAL SUBJECT TO VALID TYPE TEST REPORTS, TO BE CHECKED DURING ACCEPTANCE TESTS
 2. FOR EPC CONTRACTS ONLY

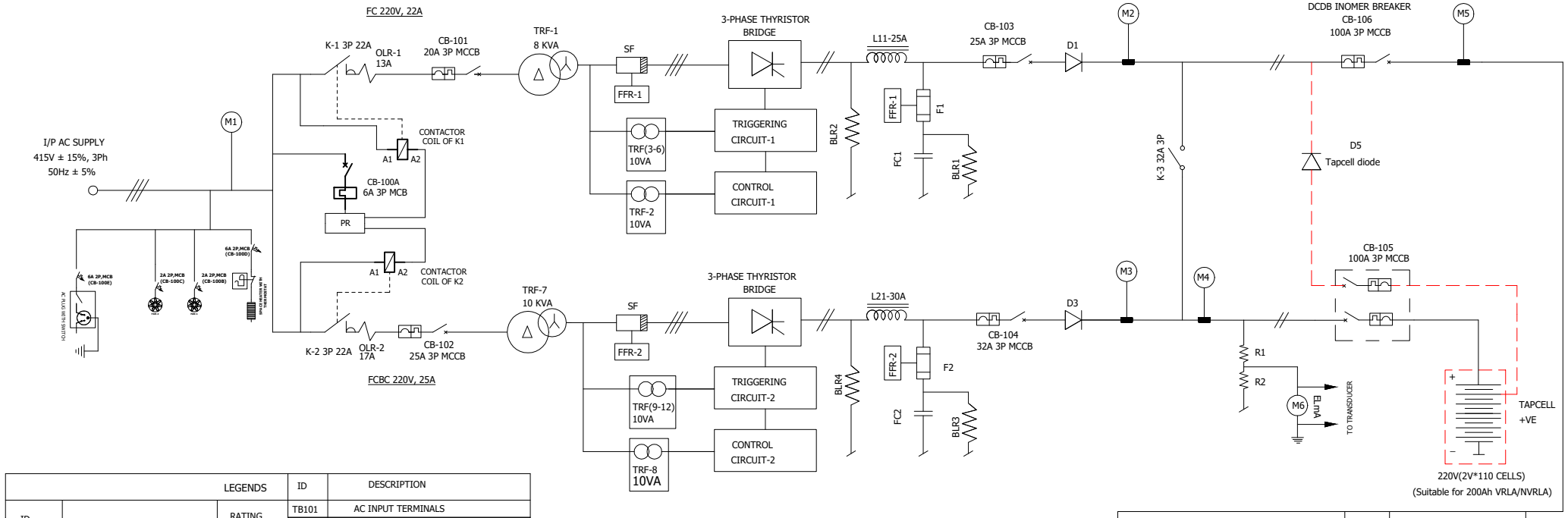

LEGENDS		ID	DESCRIPTION
ID	RATING	TB101	AC INPUT TERMINALS
		TB102	BATTERY TERMINALS
		TB103	FEEDER TERMINALS
CB-100A	CHARGER ON/OFF BREAKER 6A 3P MCB	TB104	PFC TERMINALS
CB-100B	FAN 1 CIRCUIT BREAKER 6A 2P MCB	TB105	RS-485 TERMINALS
CB-100C	FAN 2 CIRCUIT BREAKER 6A 2P MCB	TB106	TRANSDUCER TERMINALS
CB-100D	THERMOSTAT BREAKER 6A 2P MCB	TB107	ANNUNCIATOR AUX SUPPLY
CB-100E	BREAKER FOR SWITCH BOARD (6A) 6A 2P MCB	DLS	DOOR LIMIT SWITCH
CB-101	FC INPUT BREAKER 20A 3P MCCB	M1	AC DIGITAL MULTIFUNCTION METER
CB-102	FCBC INPUT BREAKER 20A 3P MCCB	M2	FC MULTIFUNCTION METER(DC DIGITAL)
CB-103	FC OUTPUT BREAKER 25A 3P MCCB	M3	FCBC MULTIFUNCTION METER(DC DIGITAL)
CB-104	FCBC OUTPUT BREAKER 32A 3P MCCB	M4	BATTERY CHARGE/DISCHARGE METER(DC DIGITAL)
CB-105	BATTERY BREAKER 100A 3P MCCB	M5	LOAD MULTIFUNCTION METER(DC DIGITAL)
CB-106	DCDB INCOMER 100A 3P MCCB	M6	EARTH LEAKAGE METER(ANALOG)
K1	FC AC CONTACTOR 22A 3P	P1	FLOAT VOLTAGE ADJUST POT(FC)
K2	FCBC AC CONTACTOR 22A 3P	P2	FLOAT VOLTAGE ADJUST POT(VRLA)(FCBC)
K3	DC CONTACTOR 32A 3P	P3	BOOST VOLTAGE ADJUST POT(VRLA)(FCBC)
L1-L3	R,Y,B INDICATION	P4	FLOAT VOLTAGE ADJUST POT(NVRLA)(FCBC)
L4 & L5	FLOAT ON & BOOST ON	P5	BOOST VOLTAGE ADJUST POT(NVRLA)(FCBC)
L6	DC CONTACTOR ON	P6	EQUALIZE VOLTAGE ADJUST POT(NVRLA)(FCBC)
FDR1-36	FEEDER ON LEDS	P7	BATTERY CURRENT LIMIT
SW1	VRLA/NVRLA MODE SELECTOR SWITCH		
SW2	FLOAT/ BOOST OF VRLA & FLOAT/ BOOST/EQUALIZE OF NVRLA SELECTOR SWITCH		
SW2	AUTO/MANUAL FLOAT/MANUAL BOOST SELECTOR SWITCH		
PR	Protective Relay(Over / Under Voltage, Over / Under Frequency, Phase (Failure, Sequence))		
DCDB	DCDB INCOMER ON LED		

Drawing approval subject to valid vendor registration

Chief Engineer/Projects
APTRANSCO/VS/Vijayawada.

OWNER	APTRANSCO	DRN	DP	SCALE	NTS
		CHD	DP	DATE	26.06.2023
01	26.06.2023	STANDARD DRAWING	APPD	RJR	SHEET NO.
00	21.06.2023	STANDARD DRAWING			04 OF 16
REV	DATE	MODIFICATIONS	TITLE	PAGE TYPE	SINGLE LINE DIAGRAM
		ALL DIMENSIONS ARE IN MM UNLESS OTHERWISE SPECIFIED.			DRAWING No. APT STD
					REV. 01

NOTE: 1. DRAWING APPROVAL SUBJECT TO VALID TYPE TEST REPORTS, TO BE CHECKED DURING ACCEPTANCE TESTS

GENERAL ARRANGEMENT

2. FOR EPC CONTRACTS ONLY

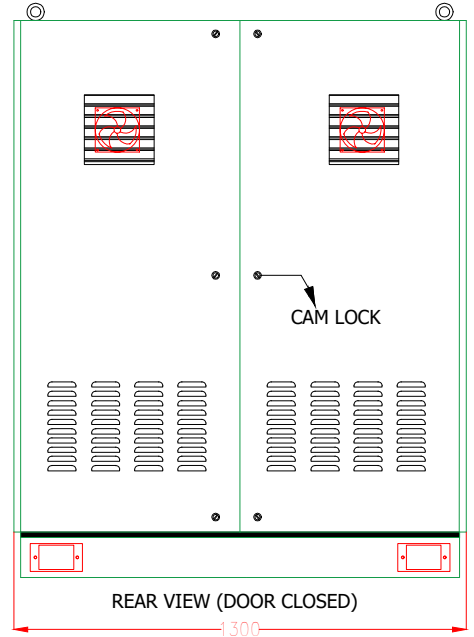
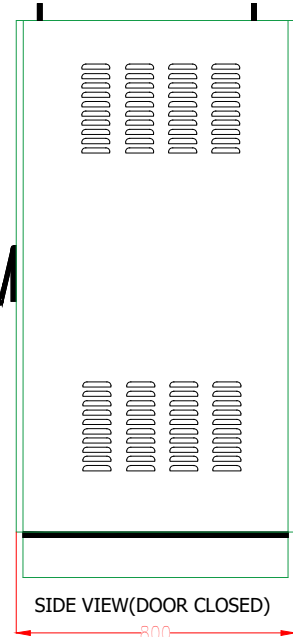
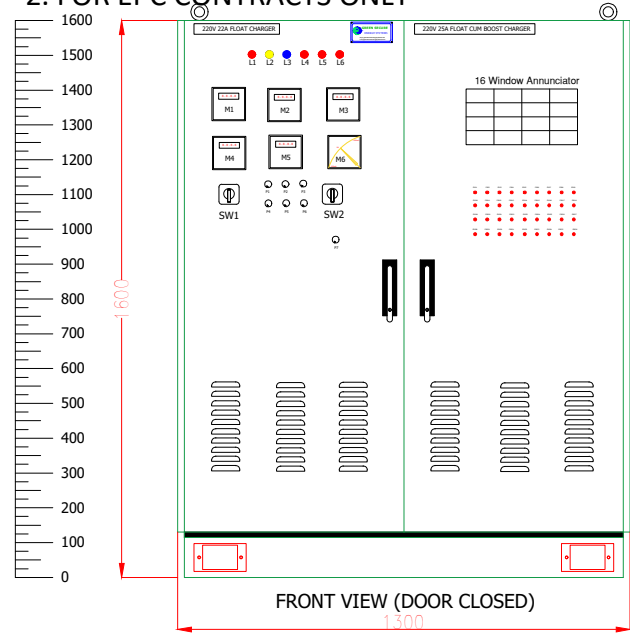

Drawing approval subject to valid vendor registration

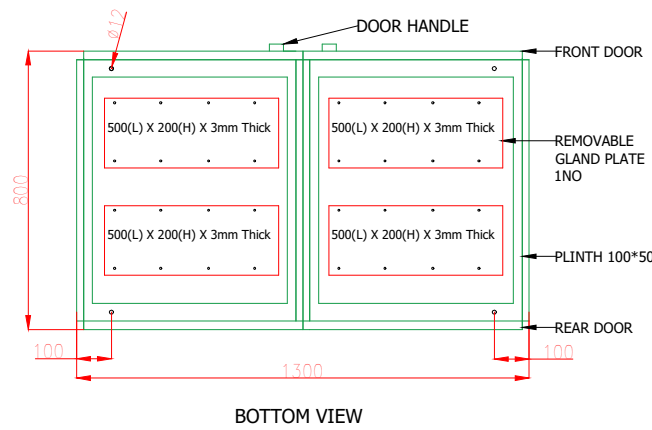

- NOTE :**
- PANEL WIDTH & DEPTH DIMENSIONS ARE INCLUDING DOORS
 - FRONT & REAR HINGED DOORS WITH FIXED SIDE DOORS.
 - MATERIAL : CRCA SHEET STEEL
 - GLAND PLATE : 3mm
 - LOAD BEARING : 2.5mm
 - NON -LOAD BEARING : 2mm
 - PAINT : 631 of IS-5
 - CABLE ENTRY : FROM BOTTOM
 - EARTH BUSBAR : 25 X 3 TINNED COPPER
 - IP PROTECTION : IP42

		LEGENDS		ID	DESCRIPTION
ID		RATING	TB101	AC INPUT TERMINALS	
			TB102	BATTERY TERMINALS	
CB-100A	CHARGER ON/OFF BREAKER	6A 3P MCB	TB103	FEEDER TERMINALS	
CB-100B	THERMOSTAT BREAKER	6A 2P MCB	TB104	PFC TERMINALS	
CB-100C	FAN 1 CIRCUIT BREAKER	6A 2P MCB	TB105	RS-485 TERMINALS	
CB-100D	FAN 2 CIRCUIT BREAKER	6A 2P MCB	TB106	TRANSDUCER TERMINALS	
CB-100E	BREAKER FOR SWITCH BOARD (6A)	6A 2P MCB	TB107	ANNUNCIATOR AUX SUPPLY	
CB-101	FC INPUT BREAKER	20A 3P MCCB	DLS	DOOR LIMIT SWITCH	
CB-102	FCBC INPUT BREAKER	20A 3P MCCB	M1	AC DIGITAL MULTIFUNCTION METER	
CB-103	FC OUTPUT BREAKER	32A 3P MCCB	M2	FC MULTIFUNCTION METER(DC DIGITAL)	
CB-104	FCBC OUTPUT BREAKER	32A 3P MCCB	M3	FCBC MULTIFUNCTION METER(DC DIGITAL)	
CB-105	BATTERY BREAKER	100A 3P MCCB	M4	BATTERY CHARGE/DISCHARGE METER(DC DIGITAL)	
CB-106	DCDB INCOMER	100A 3P MCCB	M5	LOAD MULTIFUNCTION METER(DC DIGITAL)	
K1	FC AC CONTACTOR	18A 3P	M6	EARTH LEAKAGE METER(ANALOG)	
K2	FCBC AC CONTACTOR	18A 3P	P1	FLOAT VOLTAGE ADJUST POT(FC)	
K3	DC CONTACTOR	32A 3P	P2	FLOAT VOLTAGE ADJUST POT(VRLA)(FCBC)	
L1-L3	R,Y,B INDICATION		P3	BOOST VOLTAGE ADJUST POT(VRLA)(FCBC)	
L4 & L5	FLOAT ON & BOOST ON		P4	FLOAT VOLTAGE ADJUST POT(NVRLA)(FCBC)	
L6	DC CONTACTOR ON		P5	BOOST VOLTAGE ADJUST POT(NVRLA)(FCBC)	
FDR1-36	FEEDER ON LEDS		P6	EQUALIZE VOLTAGE ADJUST POT(NVRLA)(FCBC)	
SW1	VRLA/NVRLA MODE SELECTOR SWITCH		P7	BATTERY CURRENT LIMIT	
SW2	FLOAT/ BOOST OF VRLA & FLOAT/ BOOST/EQUALIZE OF NVRLA SELECTOR SWITCH				
	AUTO/MANUAL FLOAT/MANUAL BOOST SELECTOR SWITCH				
PR	Protective Relay(Over / Under Voltage, Over / Under Frequency, Phase (Failure, Sequence))				
DCDB	DCDB INCOMER ON LED				

Chief Engineer/Projects
APTRANSCO/VS/Vijayawada.

OWNER	APTRANSCO	DRN	DP	SCALE	NTS
DATE	26.06.2023	CHD	DP	DATE	26.06.2023
MODIFICATIONS	STANDARD DRAWING	APPD	RJR	SHEET NO.	05 OF 16
	STANDARD DRAWING	DRAWING No.	APT STD	REV.	01
ALL DIMENSIONS ARE IN MM UNLESS OTHERWISE SPECIFIED.		TITLE	220VDC / 200Ah, 22A FC & 25A FCBC WITH DCDB		
REV	DATE	PAGE TYPE	GENERAL ARRANGEMENT		

ALL INFORMATION CONTAINED IN THIS DOCUMENT IS CONFIDENTIAL AND COPYRIGHT THEREOF IS RESERVED BY GREEN SECURE ENERGY SYSTEMS. THEY SHALL NOT BE USED FOR ANY PURPOSE OTHER THAN FOR WHICH THEY ARE SUPPLIED AND SHALL NOT BE COPIED OR REPRODUCED WITHOUT WRITTEN PERMISSION.

558541/2023/EEMRT-ENE51

AC CIRCUIT FOR FC & FCBC

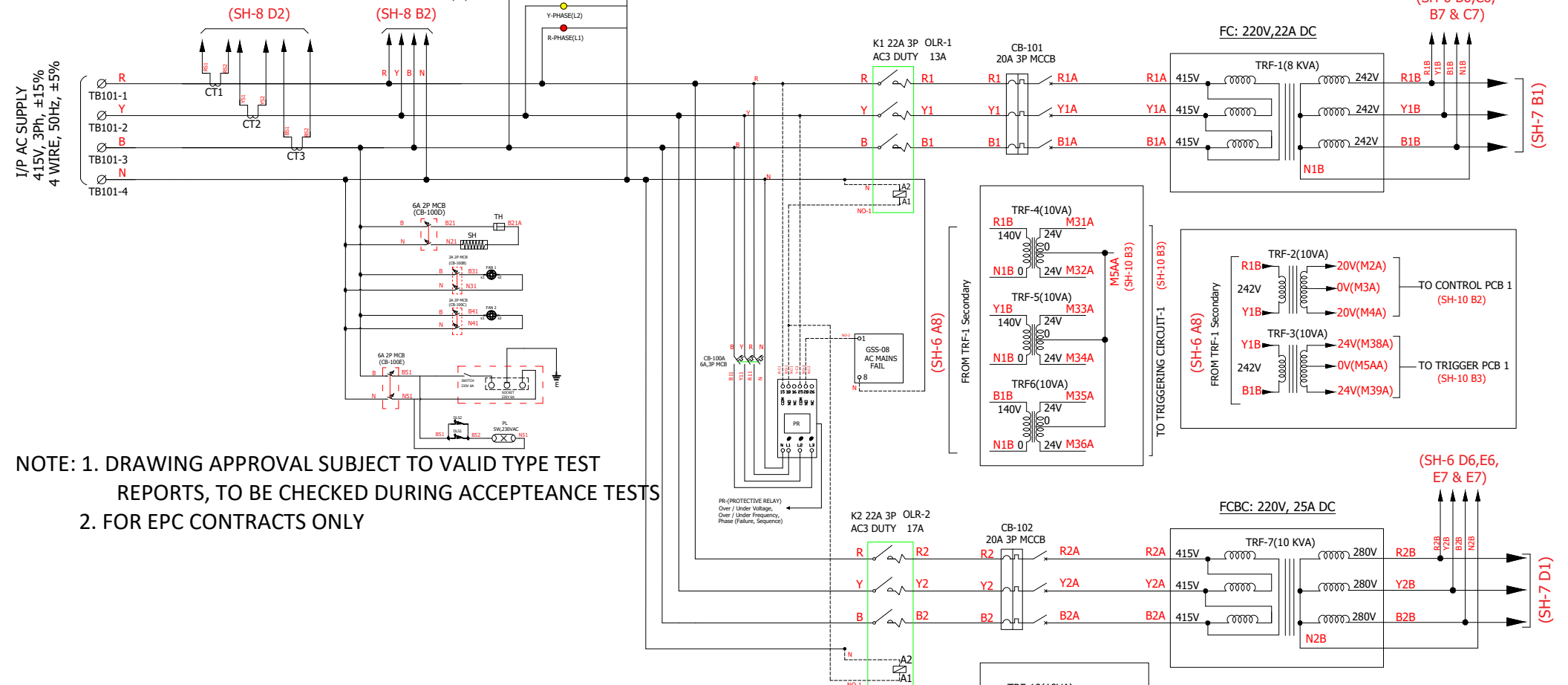

NOTE: 1. DRAWING APPROVAL SUBJECT TO VALID TYPE TEST REPORTS, TO BE CHECKED DURING ACCEPTANCE TESTS
 2. FOR EPC CONTRACTS ONLY

Drawing approval subject to valid vendor registration

Chief Engineer/Projects
APTRANSCO/VS/Vijayawada.

ALL INFORMATION CONTAINED IN THIS DOCUMENT IS CONFIDENTIAL AND COPYRIGHT THEREOF IS RESERVED BY GREEN SECURE ENERGY SYSTEMS, THEY SHALL NOT BE USED FOR ANY PURPOSE OTHER THAN FOR WHICH THEY ARE SUPPLIED AND SHALL NOT BE COPIED OR REPRODUCED WITHOUT WRITTEN PERMISSION.

OWNER	APTRANSCO
DATE	26.06.2023
DATE	21.06.2023
MODIFICATIONS	STANDARD DRAWING
MODIFICATIONS	STANDARD DRAWING
ALL DIMENSIONS ARE IN MM UNLESS OTHERWISE SPECIFIED.	

TITLE	220VDC / 200Ah, 22A FC & 25A FCBC WITH DCDB	
	PAGE TYPE	AC CIRCUIT FOR FC & FCBC

DRN	DP	SCALE	NTS
CHD	DP	DATE	26.06.2023
APPD	RJR	SHEET NO.	
DRAWING No.		06 OF 16	
APT STD		REV.	01

7558541/2023/EMBT/ENF51

ALL INFORMATION CONTAINED IN THIS DOCUMENT IS CONFIDENTIAL AND COPYRIGHT THEREOF IS RESERVED BY GREEN SECURE ENERGY SYSTEMS. THEY SHALL NOT BE USED FOR ANY PURPOSE OTHER THAN FOR WHICH THEY ARE SUPPLIED AND SHALL NOT BE COPIED OR REPRODUCED WITHOUT WRITTEN PERMISSION.

NOTE: 1. DRAWING APPROVAL SUBJECT TO VALID TYPE TEST REPORTS, TO BE CHECKED DURING ACCEPTANCE TESTS
2. FOR EPC CONTRACTS ONLY
DC CIRCUIT FOR FC & FCBC

Chief Engineer/Projects
APTRANSCO/VS/Vijayawada.

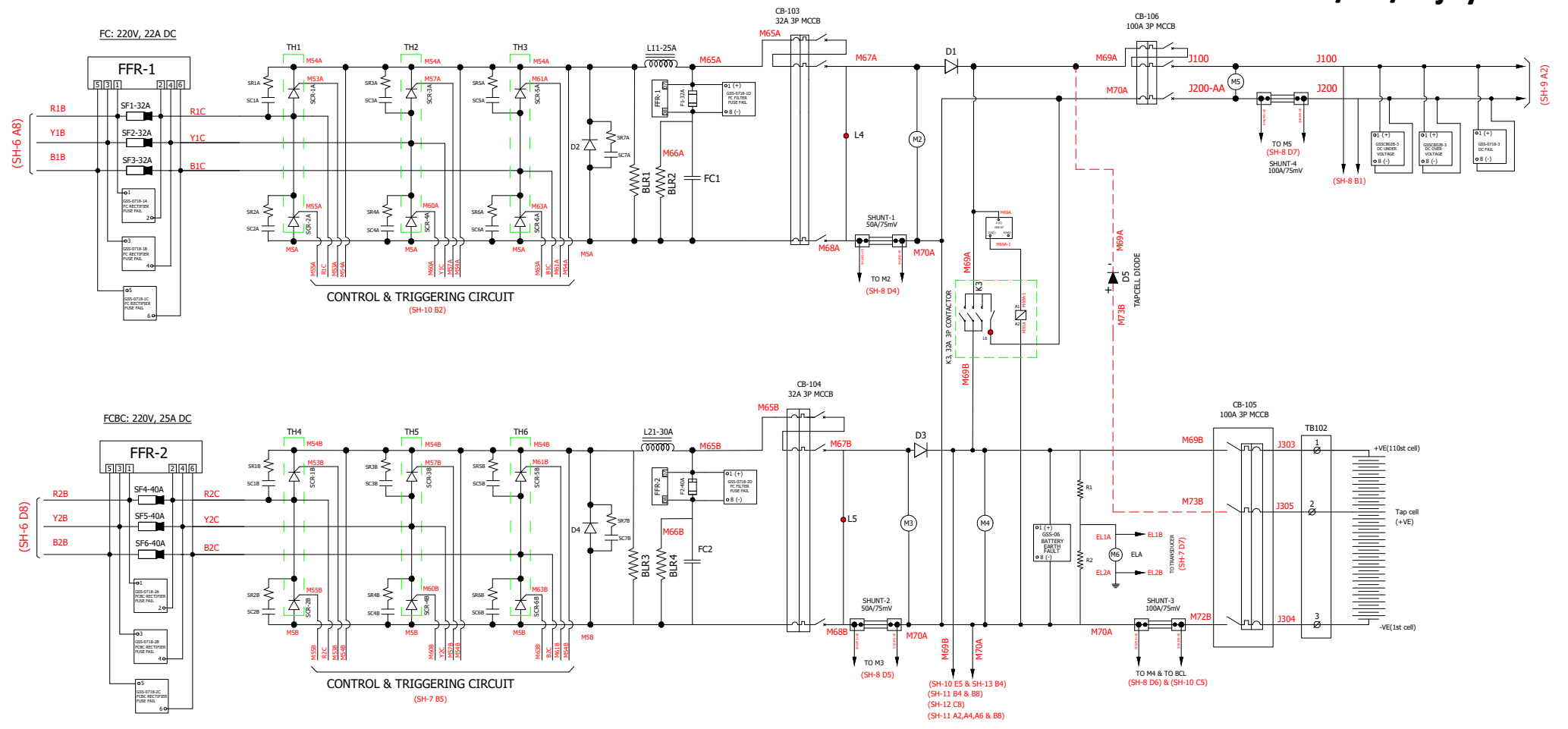

Drawing approval subject to valid vendor registration

OWNER	APTRANSCO
DATE	26.06.2023
DATE	21.06.2023
MODIFICATIONS	
ALL DIMENSIONS ARE IN MM UNLESS OTHERWISE SPECIFIED.	

TITLE	220VDC / 200Ah, 22A FC & 25A FCBC WITH DCDB	
	PAGE TYPE	DC CIRCUIT FOR FC & FCBC

DRN	DP	SCALE	NTS
CHD	DP	DATE	26.06.2023
APPD	RJR	SHEET NO.	
DRAWING No.		07 OF 16	
APT STD		REV.	01

7558541/2023/EE/PT-ENE51

ALL INFORMATION CONTAINED IN THIS DOCUMENT IS CONFIDENTIAL AND COPYRIGHT THEREOF IS RESERVED BY GREEN SECURE ENERGY SYSTEMS, THEY SHALL NOT BE USED FOR ANY PURPOSE OTHER THAN FOR WHICH THEY ARE SUPPLIED AND SHALL NOT BE COPIED OR REPRODUCED WITHOUT WRITTEN PERMISSION.

NOTE: 1. DRAWING APPROVAL SUBJECT TO VALID TYPE TEST REPORTS, TO BE CHECKED DURING ACCEPTANCE TESTS
2. FOR EPC CONTRACTS ONLY

METER CIRCUIT

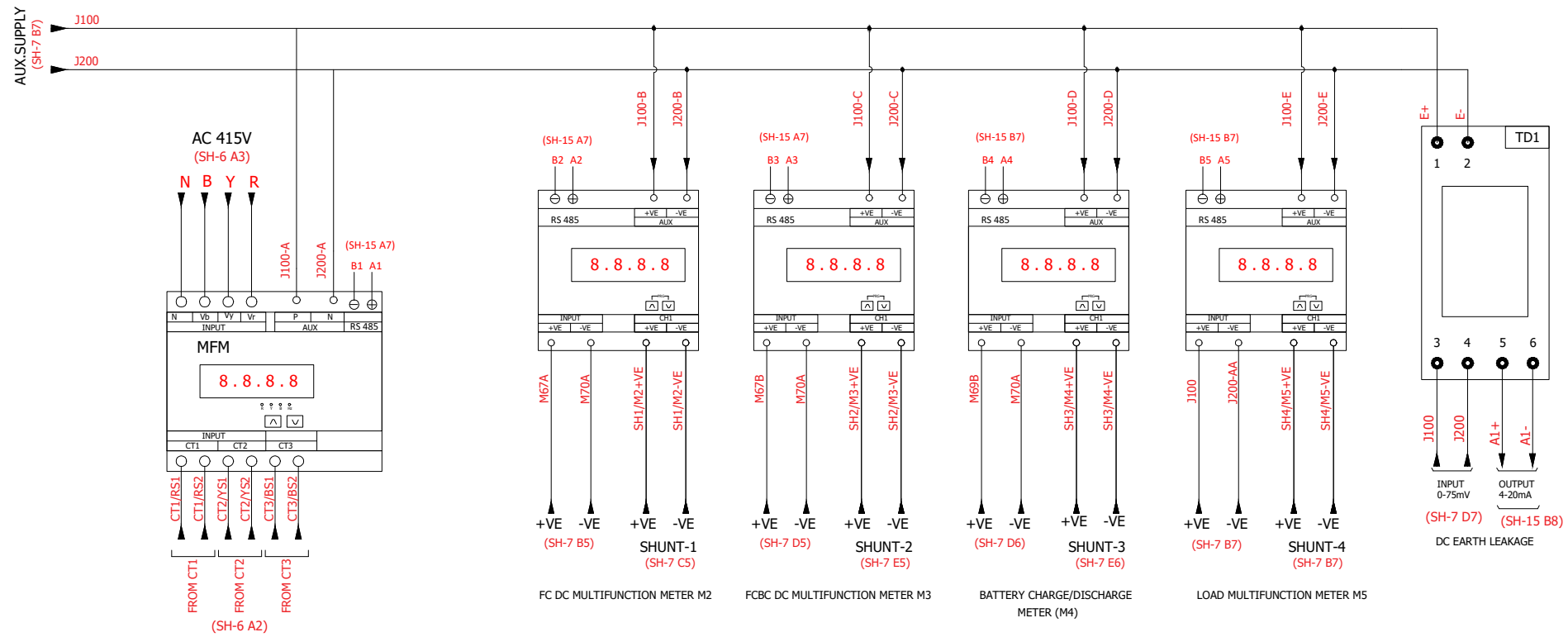

AC MULTI FUNCTION METER (M1)

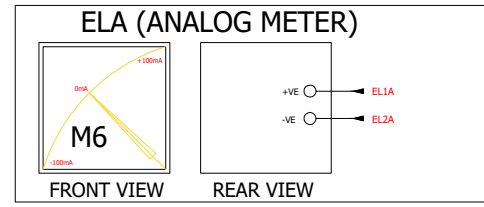

**Chief Engineer/Projects
APTRANSCO/VS/Vijawada.**

Drawing approval subject to valid vendor registration

OWNER	APTRANSCO	DRN	DP	SCALE	NTS
DATE	26.06.2023	CHD	DP	DATE	26.06.2023
MODIFICATIONS	STANDARD DRAWING	APPD	RJR	SHEET NO. 08 OF 16	
ALL DIMENSIONS ARE IN MM UNLESS OTHERWISE SPECIFIED.		DRAWING No. APT STD		REV.	01
TITLE		PAGE TYPE		METER CIRCUIT	
220VDC / 200Ah, 22A FC & 25A FCBC WITH DCDB					



GREEN SECURE ENERGY SYSTEMS,.

ALL INFORMATION CONTAINED IN THIS DOCUMENT IS CONFIDENTIAL AND COPYRIGHT THEREOF IS RESERVED BY GREEN SECURE ENERGY SYSTEMS, THEY SHALL NOT BE USED FOR ANY PURPOSE OTHER THAN FOR WHICH THEY ARE SUPPLIED AND SHALL NOT BE COPIED OR REPRODUCED WITHOUT WRITTEN PERMISSION.

58541/2023/EEMRT-ENE51

NOTE: 1. DRAWING APPROVAL SUBJECT TO VALID TYPE TEST REPORTS, TO BE CHECKED DURING ACCEPTANCE TESTS
2. FOR EPC CONTRACTS ONLY

100

Chief Engineer/Projects
APTRANSCO/VS/Vijayawada.

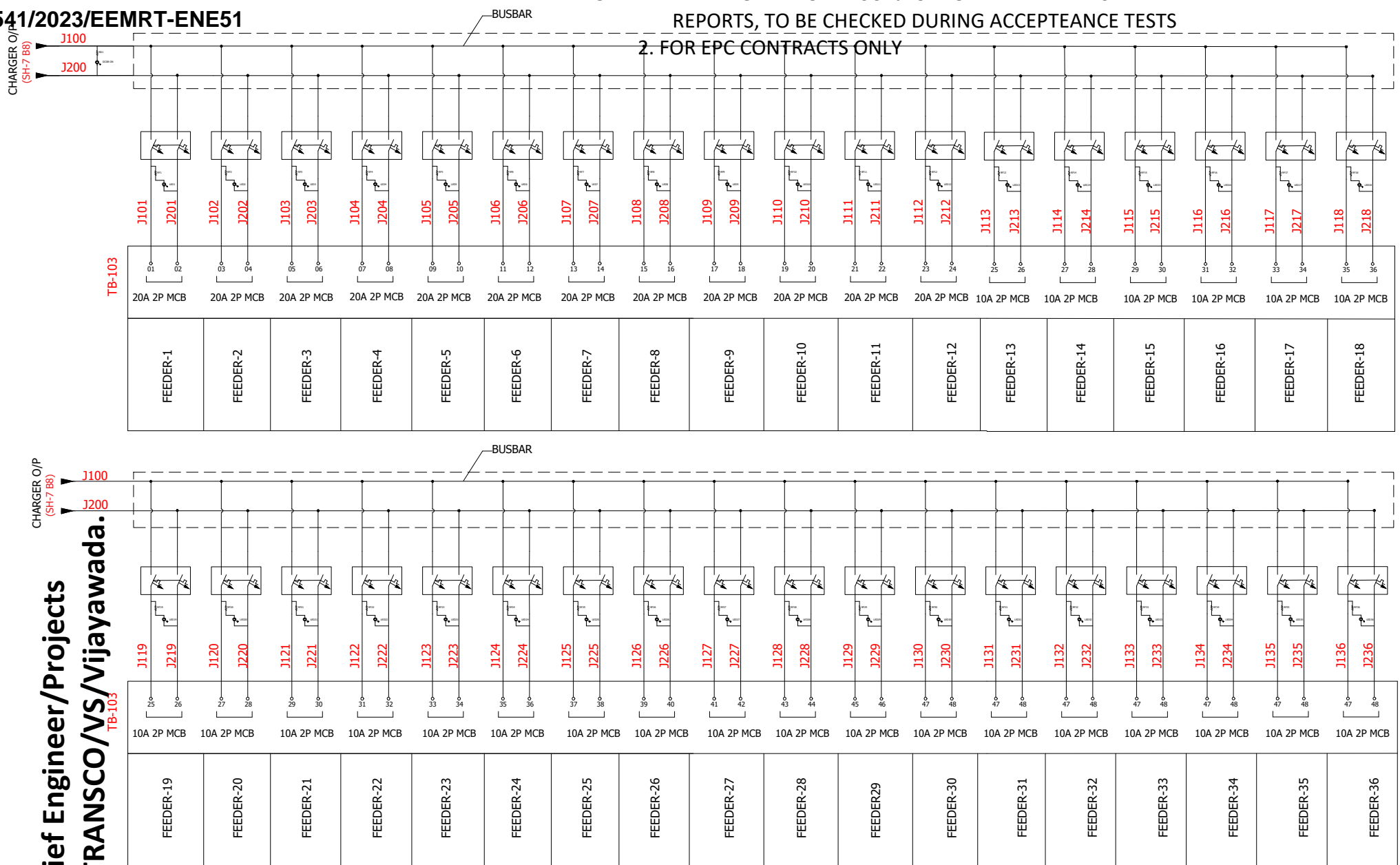

01	26.06.2023	STANDARD DRAWING
00	21.06.2023	STANDARD DRAWING
REV	DATE	MODIFICATIONS

OWNER	APTRANSCO
ALL DIMENSIONS ARE IN MM UNLESS OTHERWISE SPECIFIED.	

TITLE	220VDC / 200Ah, 22A FC & 25A FCBC WITH DCDB
PAGE TYPE	FEEDER CIRCUIT

DRN	DP	SCALE	NTS
CHD	DP	DATE	26.06.2023
APPD	RJR	SHEET NO.	
DRAWING No.		09 OF 16	
APT STD		REV.	01

7558541/2023/EEMRT-ENE51

NOTE: 1. DRAWING APPROVAL SUBJECT TO VALID TYPE TEST REPORTS, TO BE CHECKED DURING ACCEPTANCE TESTS

2. FOR EPC CONTRACTS ONLY

CONTROL & TRIGGER CIRCUIT

Chief Engineer/Projects
APTRANSCO/VS/Vijayawada.

Drawing approval subject to valid vendor registration

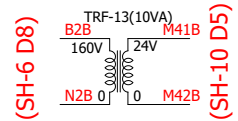
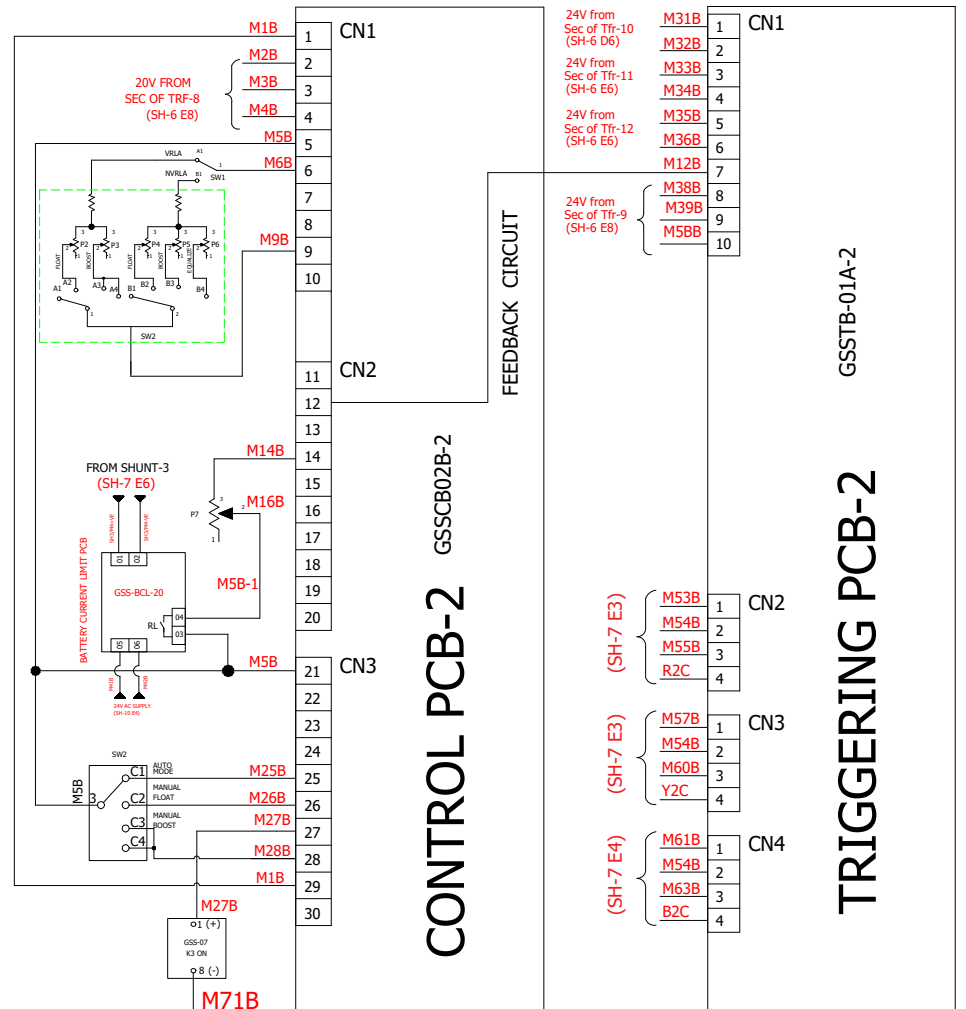
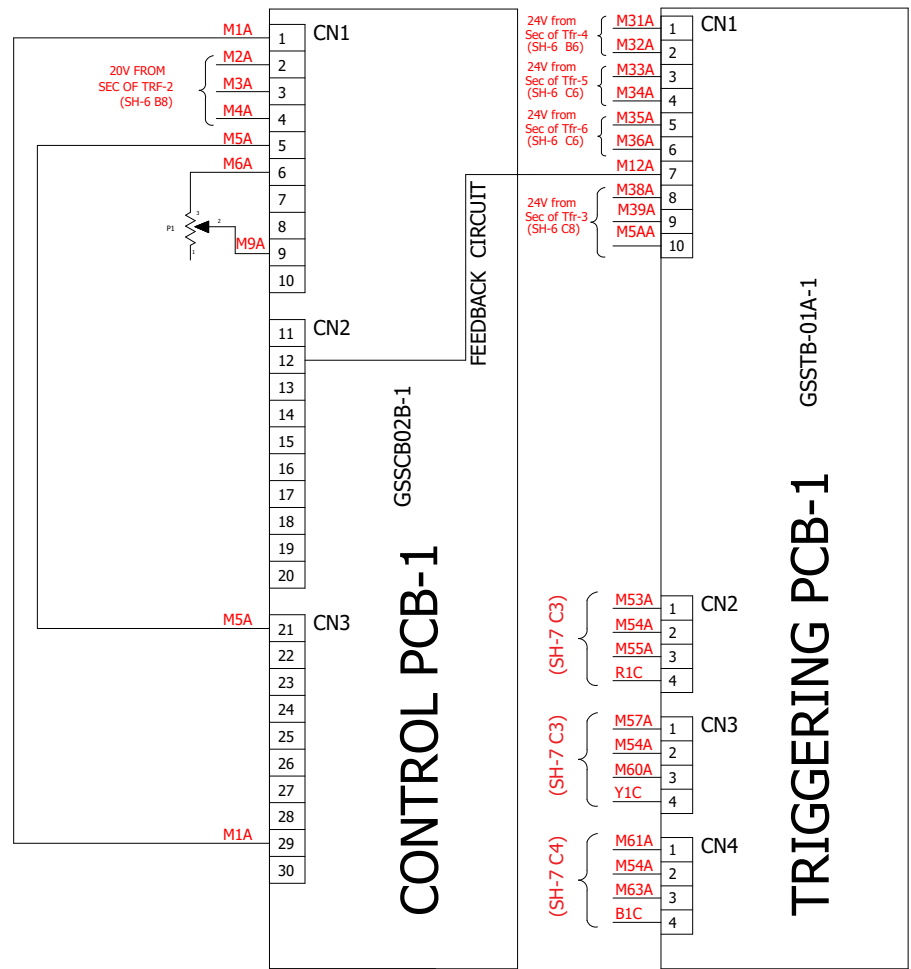

NOTE: SW1: LOCK & KEY TYPE SELECTOR SWITCH

ALL INFORMATION CONTAINED IN THIS DOCUMENT IS CONFIDENTIAL AND COPYRIGHT THEREOF IS RESERVED BY GREEN SECURE ENERGY SYSTEMS. THEY SHALL NOT BE USED FOR ANY PURPOSE OTHER THAN FOR WHICH THEY ARE SUPPLIED AND SHALL NOT BE COPIED OR REPRODUCED WITHOUT WRITTEN PERMISSION.

OWNER	APTRANSCO
DATE	26.06.2023
MODIFICATIONS	STANDARD DRAWING
DATE	21.06.2023
MODIFICATIONS	STANDARD DRAWING
ALL DIMENSIONS ARE IN MM UNLESS OTHERWISE SPECIFIED.	

TITLE	220VDC / 200Ah, 22A FC & 25A FCBC WITH DCDB	
	PAGE TYPE	CONTROL & TRIGGER CIRCUIT

DRN	DP	SCALE	NTS
CHD	DP	DATE	26.06.2023
APPD	RJR	SHEET NO. 10 OF 16	
DRAWING No. APT STD		REV.	01

NOTE: 1. DRAWING APPROVAL SUBJECT TO VALID TYPE TEST

FUSE FAILURE RELAY CIRCUIT

2. FOR EPC CONTRACTS ONLY

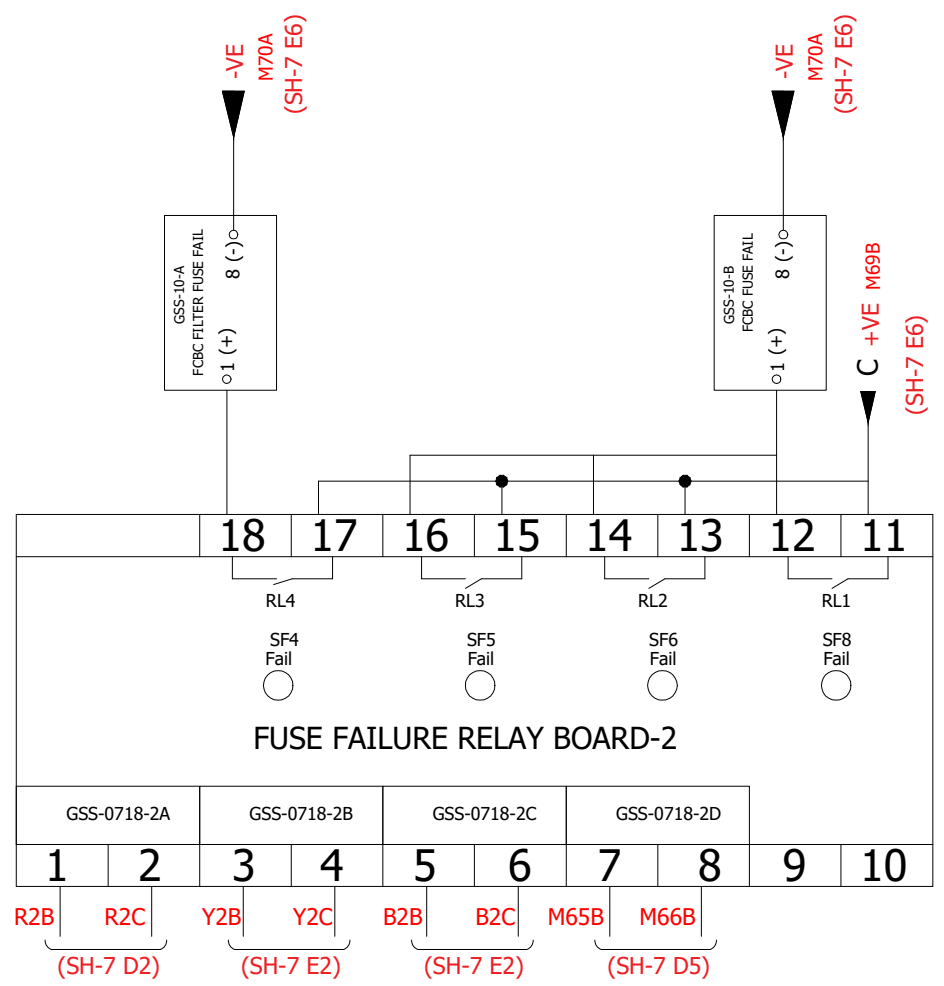
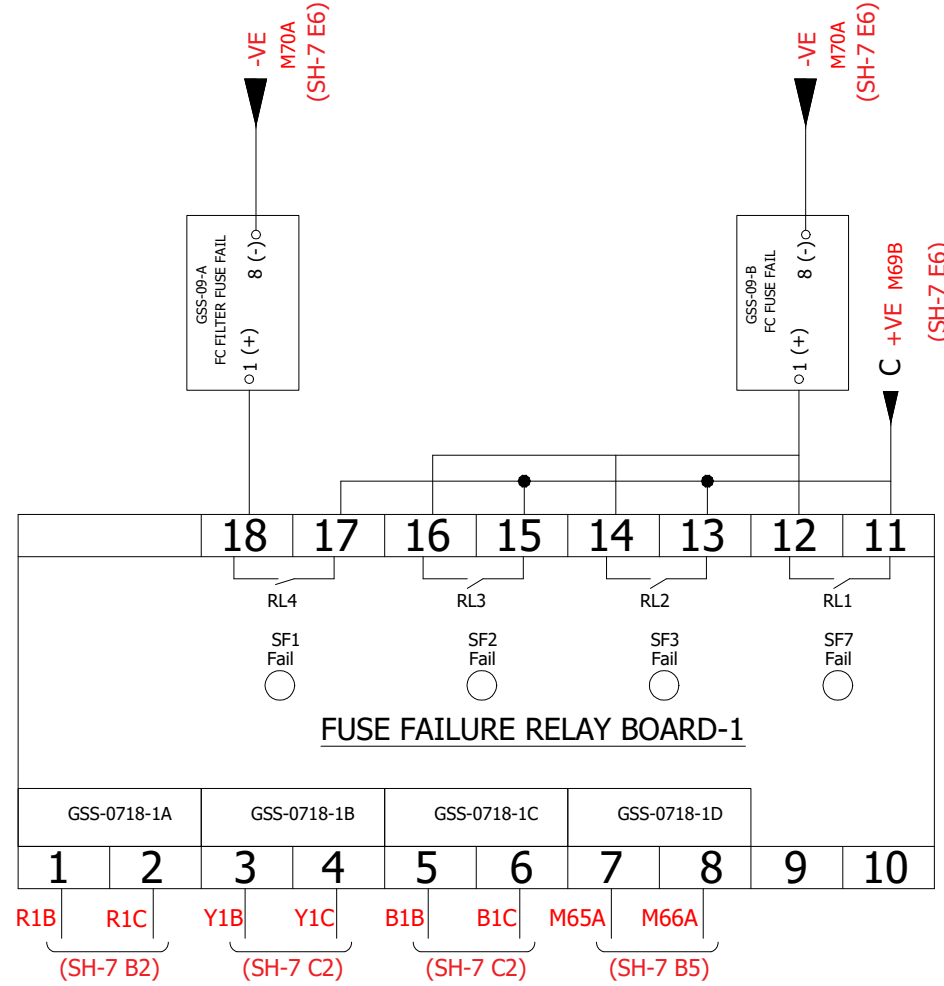

Drawing approval subject to valid vendor registration

**Chief Engineer/Projects
APTRANSCO/Vs/Vijayawada.**

01	26.06.2023	STANDARD DRAWING	OWNER	APTRANSCO	GREEN SECURE ENERGY SYSTEMS,.	DRN	DP	SCALE	NTS	
00	21.06.2023	STANDARD DRAWING					CHD	DP	DATE	26.06.2023
REV	DATE	MODIFICATIONS	ALL DIMENSIONS ARE IN MM UNLESS OTHERWISE SPECIFIED.			TITLE	APPD	RJR	SHEET NO. 11 OF 16	
						PAGE TYPE	DRAWING No. APT STD		REV.	01
						220VDC / 200Ah, 22A FC & 25A FCBC WITH DCDB				
						FUSE FAILURE RELAY CIRCUIT				

ALL INFORMATION CONTAINED IN THIS DOCUMENT IS CONFIDENTIAL AND COPYRIGHT THEREOF IS RESERVED BY GREEN SECURE ENERGY SYSTEMS. THEY SHALL NOT BE USED FOR ANY PURPOSE OTHER THAN FOR WHICH THEY ARE SUPPLIED AND SHALL NOT BE COPIED OR REPRODUCED WITHOUT WRITTEN PERMISSION.

NOTE: 1. DRAWING APPROVAL SUBJECT TO VALID TYPE TEST

7558541/2023/EMPT-EN-51 CHECKED DURING ACCEPTANCE TESTS

ALARM ANNUNCIATOR

2. FOR EPC CONTRACTS ONLY

FAULT COMMON(FC)

IC: INITIATING CONTACTS

X21

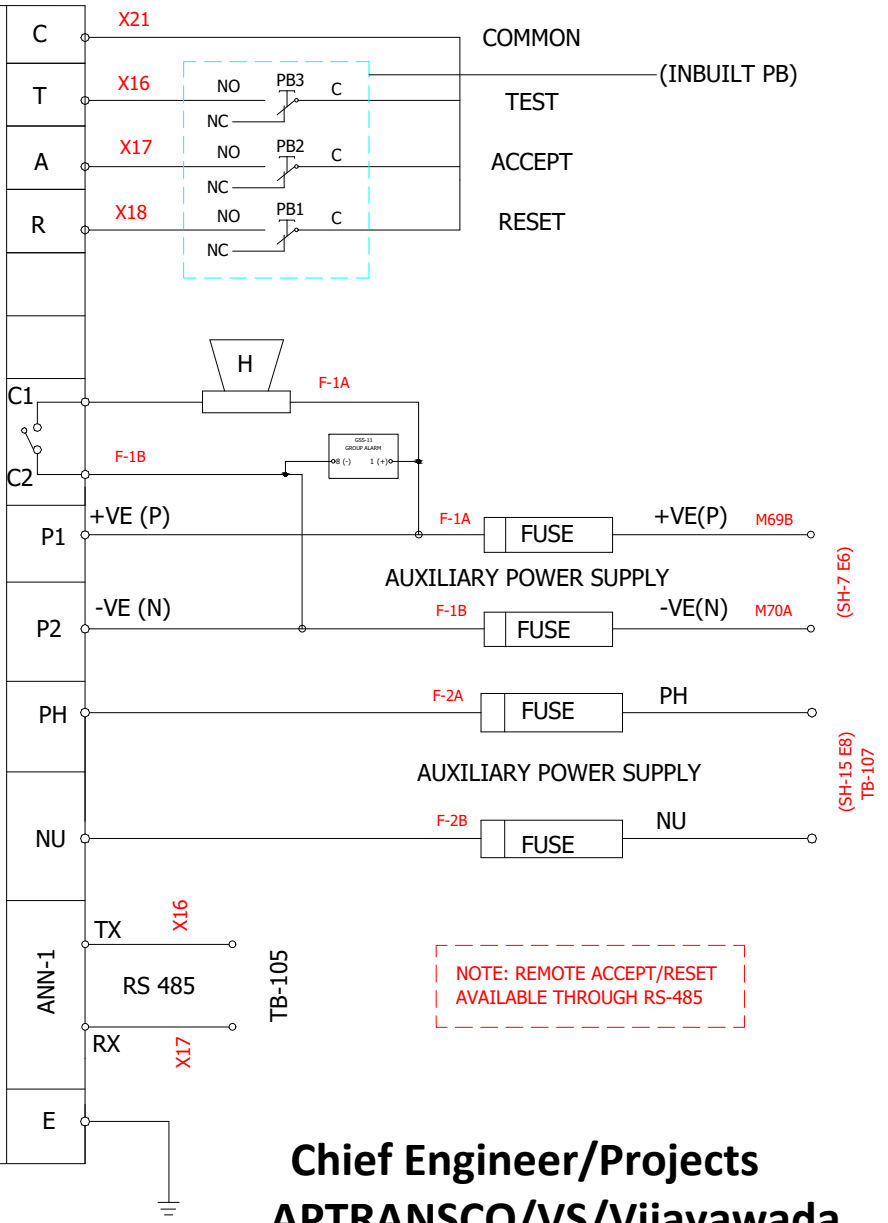
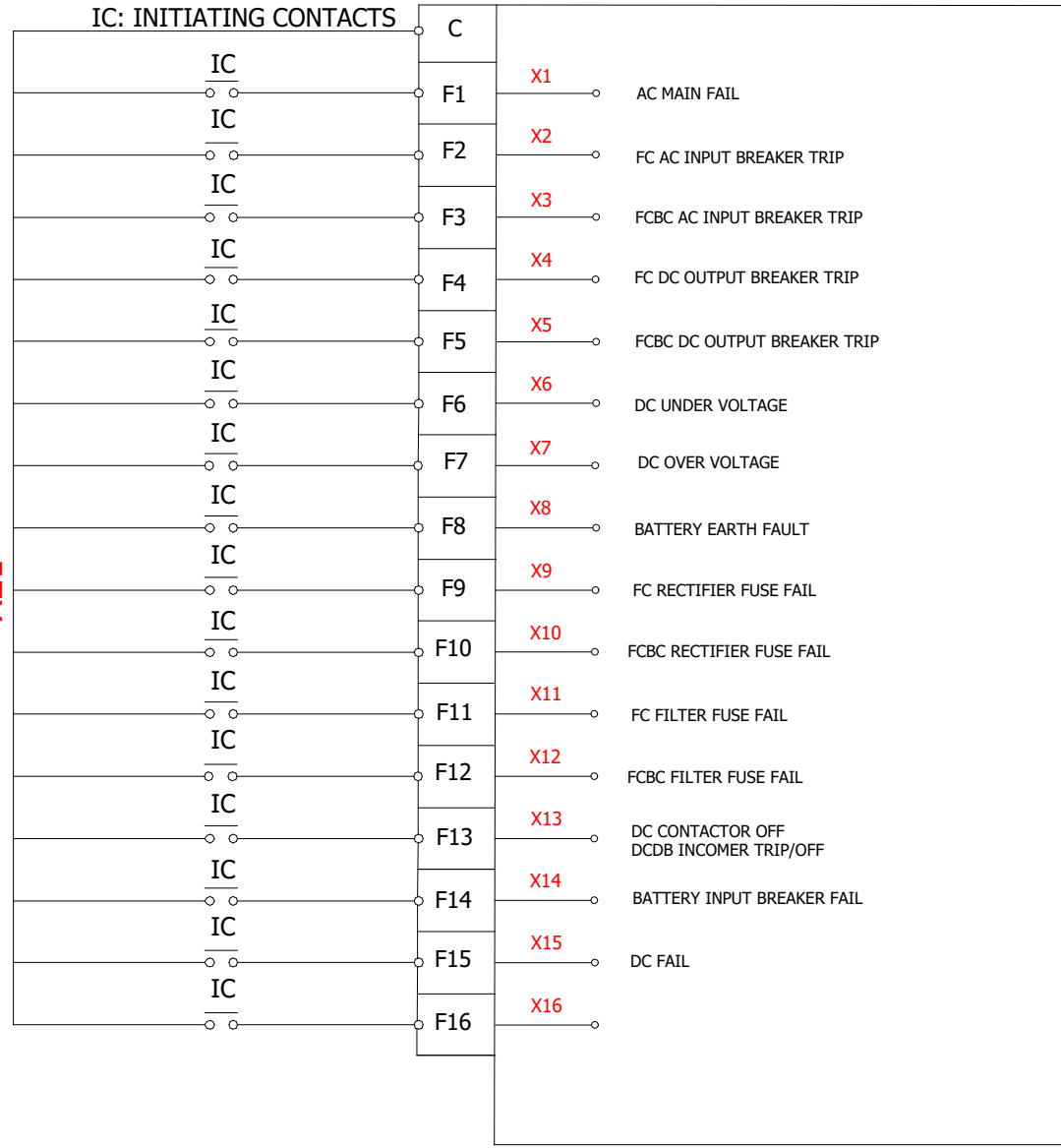

NOTE: REMOTE ACCEPT/RESET AVAILABLE THROUGH RS-485

Chief Engineer/Projects
APTRANSCO/VS/Vijayawada.

ALL INFORMATIONS CONTAINED IN THIS DOCUMENT IS CONFIDENTIAL AND COPYRIGHT THEREOF IS RESERVED BY GREEN SECURE ENERGY SYSTEMS, THEY SHALL NOT BE USED FOR ANY PURPOSE OTHER THAN FOR WHICH THEY ARE SUPPLIED AND SHALL NOT BE COPIED OR REPRODUCED WITHOUT WRITTEN PERMISSION.

OWNER	APTRANSCO	GREEN SECURE ENERGY SYSTEMS,.	DRN	DP	SCALE	NTS
REV	DATE		MODIFICATIONS	CHD	DP	DATE
01	26.06.2023	STANDARD DRAWING	APPD	RJR	SHEET NO.	
00	21.06.2023	STANDARD DRAWING	DRAWING No.		12 OF 16	
ALL DIMENSIONS ARE IN MM UNLESS OTHERWISE SPECIFIED.			APT STD	REV.	01	
TITLE	220VDC / 200Ah, 22A FC & 25A FCBC WITH DCDB		PAGE TYPE	ALARM ANNUNCIATOR		

NOTE: 1. DRAWING APPROVAL SUBJECT TO VALID TYPE TEST

REPORTS, TO BE CHECKED DURING ACCEPTANCE TESTS

2. FOR EPC CONTRACTS ONLY

ALARM ANNUNCIATOR

Chief Engineer/Projects APTRANSCO/VS/Vijayawada.

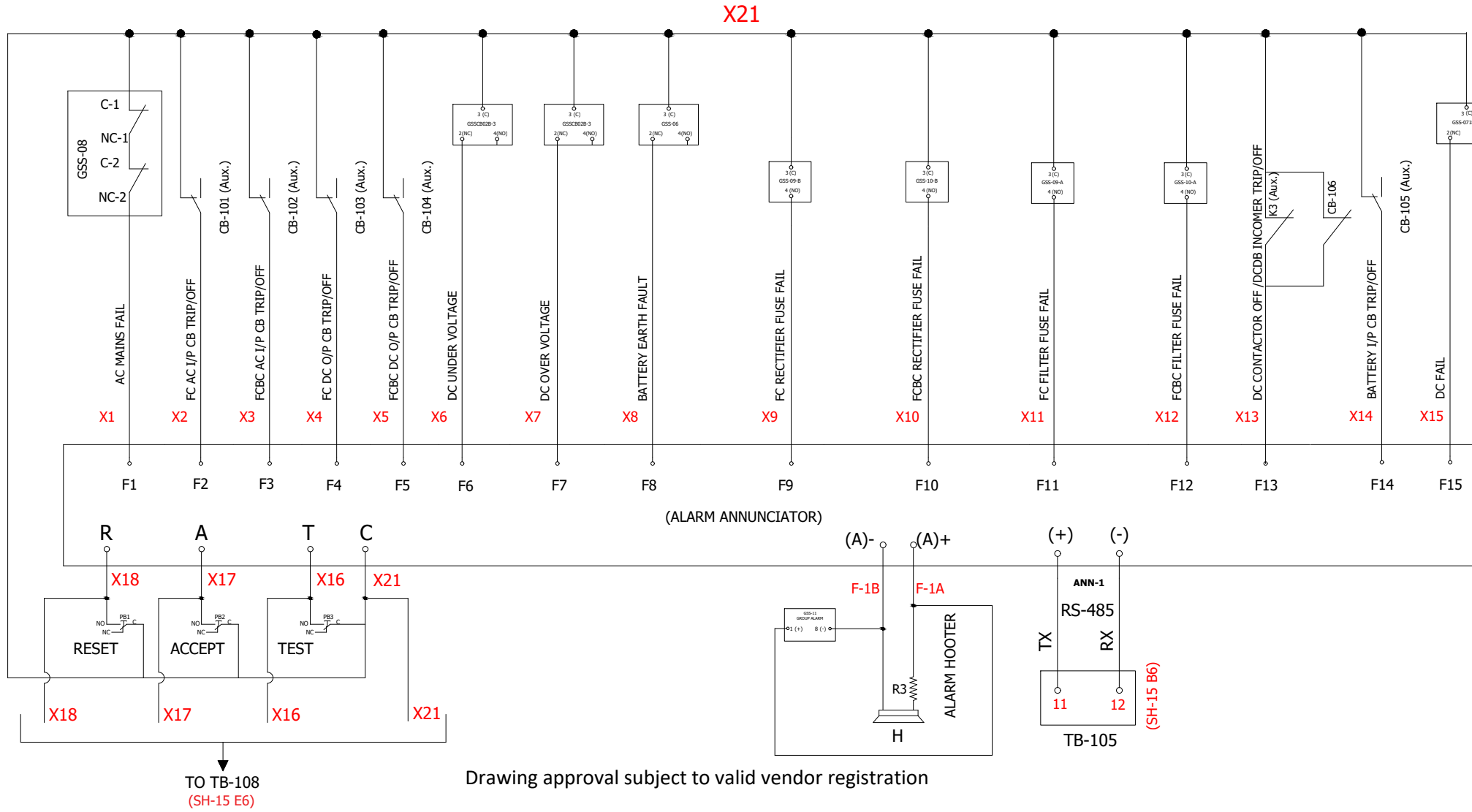

TO TB-108
(SH-15 E6)

Drawing approval subject to valid vendor registration

OWNER	APTRANSCO
DATE	26.06.2023
DATE	21.06.2023
MODIFICATIONS	
ALL DIMENSIONS ARE IN MM UNLESS OTHERWISE SPECIFIED.	

TITLE	220VDC / 200Ah, 22A FC & 25A FCBC WITH DCDB	
	PAGE TYPE	ALARM ANNUNCIATOR

DRN	DP	SCALE	NTS
CHD	DP	DATE	26.06.2023
APPD	RJR	SHEET NO.	
DRAWING No.		13 OF 16	
APT STD		REV.	01

ALL INFORMATION CONTAINED IN THIS DOCUMENT IS CONFIDENTIAL AND COPYRIGHT THEREOF IS RESERVED BY GREEN SECURE ENERGY SYSTEMS. THEY SHALL NOT BE USED FOR ANY PURPOSE OTHER THAN FOR WHICH THEY ARE SUPPLIED AND SHALL NOT BE COPIED OR REPRODUCED WITHOUT WRITTEN PERMISSION.

NOTE: 1. DRAWING APPROVAL SUBJECT TO VALID TYPE TEST REPORTS, TO BE CHECKED DURING ACCEPTANCE TESTS

2. FOR EPC CONTRACTS ONLY

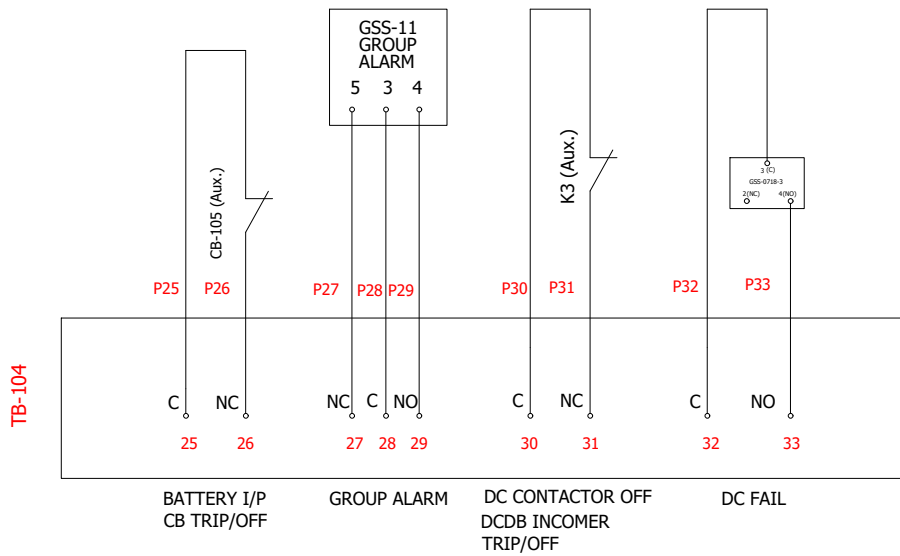
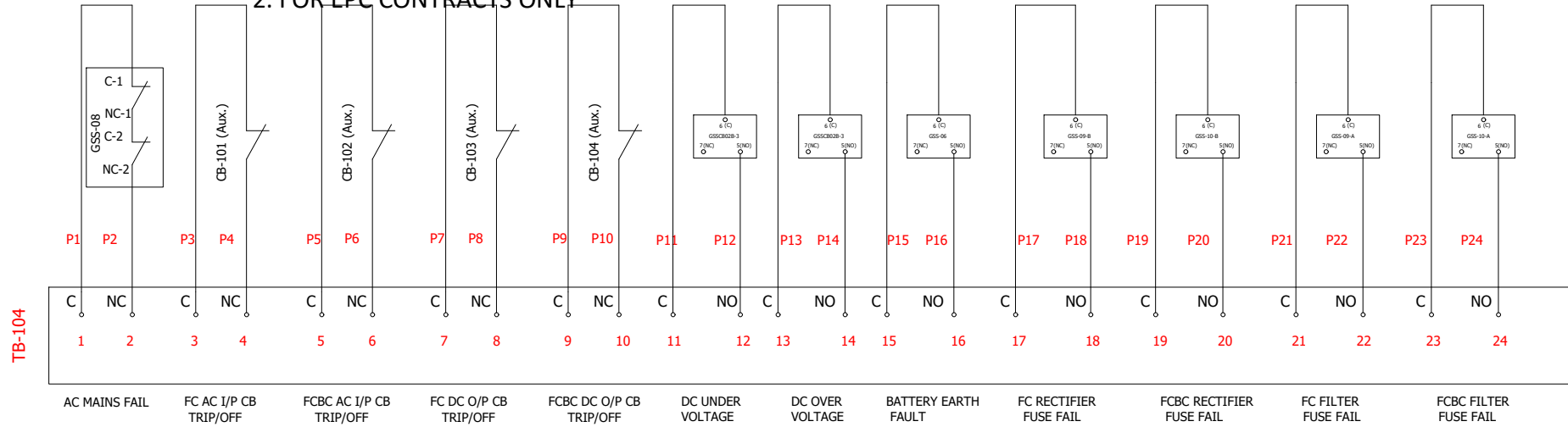

Drawing approval subject to valid vendor registration

Chief Engineer/Projects
APTRANSCO/VS/Vijayawada.

01	26.06.2023	STANDARD DRAWING	OWNER	APTRANSCO		DRN	DP	SCALE	NTS
00	21.06.2023	STANDARD DRAWING				CHD	DP	DATE	26.06.2023
REV	DATE	MODIFICATIONS	ALL DIMENSIONS ARE IN MM UNLESS OTHERWISE SPECIFIED.			TITLE	APPD	RJR	SHEET NO. 14 OF 16
					PAGE TYPE	PFC TERMINALS		DRAWING No.	APT STD
								REV.	01

ALL INFORMATION CONTAINED IN THIS DOCUMENT IS CONFIDENTIAL AND COPYRIGHT THEREOF IS RESERVED BY GREEN SECURE ENERGY SYSTEMS. THEY SHALL NOT BE USED FOR ANY PURPOSE OTHER THAN FOR WHICH THEY ARE SUPPLIED AND SHALL NOT BE COPIED OR REPRODUCED WITHOUT WRITTEN PERMISSION.

NOTE: 1. DRAWING APPROVAL SUBJECT TO VALID TYPE TEST REPORTS, TO BE CHECKED DURING ACCEPTANCE TESTS

2. FOR EPC CONTRACTS ONLY

CHARGER TERMINAL DETAILS

RS-485 TERMINALS

TB-105

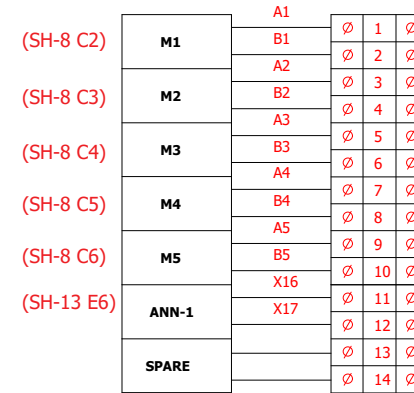

TRANSDUCER TERMINALS

TB-106

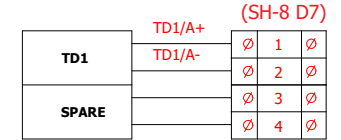

BATTERY TERMINALS

TB-102

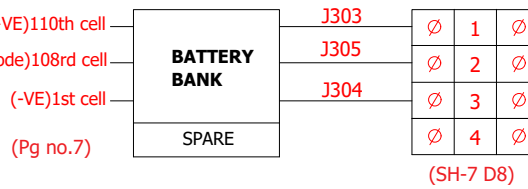

AC INPUT TERMINALS

TB-101

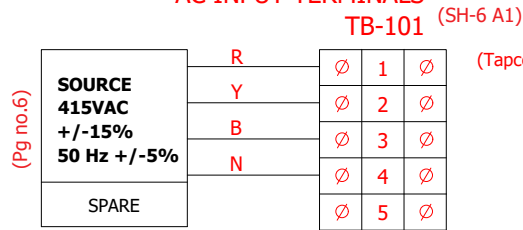

FEEDER TERMINALS

TB-103

FEEDER 1	J101	∅ 1	∅
FEEDER 1	J201	∅ 2	∅
FEEDER 2	J102	∅ 3	∅
FEEDER 2	J202	∅ 4	∅
FEEDER 3	J103	∅ 5	∅
FEEDER 3	J203	∅ 6	∅
FEEDER 4	J104	∅ 7	∅
FEEDER 4	J204	∅ 8	∅
FEEDER 5	J105	∅ 9	∅
FEEDER 5	J205	∅ 10	∅
FEEDER 6	J106	∅ 11	∅
FEEDER 6	J206	∅ 12	∅
FEEDER 7	J107	∅ 13	∅
FEEDER 7	J207	∅ 14	∅
FEEDER 8	J108	∅ 15	∅
FEEDER 8	J208	∅ 16	∅
FEEDER 9	J109	∅ 17	∅
FEEDER 9	J209	∅ 18	∅
FEEDER 10	J110	∅ 19	∅
FEEDER 10	J210	∅ 20	∅
FEEDER 11	J111	∅ 21	∅
FEEDER 11	J211	∅ 22	∅
FEEDER 12	J112	∅ 23	∅
FEEDER 12	J212	∅ 24	∅

TB-103

FEEDER 13	J113	∅ 25	∅
FEEDER 13	J213	∅ 26	∅
FEEDER 14	J114	∅ 27	∅
FEEDER 14	J214	∅ 28	∅
FEEDER 15	J115	∅ 29	∅
FEEDER 15	J215	∅ 30	∅
FEEDER 16	J116	∅ 31	∅
FEEDER 16	J216	∅ 32	∅
FEEDER 17	J117	∅ 33	∅
FEEDER 17	J217	∅ 34	∅
FEEDER 18	J118	∅ 35	∅
FEEDER 18	J218	∅ 36	∅
FEEDER 19	J119	∅ 37	∅
FEEDER 19	J219	∅ 38	∅
FEEDER 20	J120	∅ 39	∅
FEEDER 20	J220	∅ 40	∅
FEEDER 21	J121	∅ 41	∅
FEEDER 21	J221	∅ 42	∅
FEEDER 22	J122	∅ 43	∅
FEEDER 22	J222	∅ 44	∅
FEEDER 23	J123	∅ 45	∅
FEEDER 23	J223	∅ 46	∅
FEEDER 24	J124	∅ 47	∅
FEEDER 24	J224	∅ 48	∅

TB-103

FEEDER 25	J125	∅ 49	∅
FEEDER 25	J225	∅ 50	∅
FEEDER 26	J126	∅ 51	∅
FEEDER 26	J226	∅ 52	∅
FEEDER 27	J127	∅ 53	∅
FEEDER 27	J227	∅ 54	∅
FEEDER 28	J128	∅ 55	∅
FEEDER 28	J228	∅ 56	∅
FEEDER 29	J129	∅ 57	∅
FEEDER 29	J229	∅ 58	∅
FEEDER 30	J130	∅ 59	∅
FEEDER 30	J230	∅ 60	∅
FEEDER 31	J131	∅ 61	∅
FEEDER 31	J231	∅ 62	∅
FEEDER 32	J132	∅ 63	∅
FEEDER 32	J232	∅ 64	∅
FEEDER 33	J133	∅ 65	∅
FEEDER 33	J233	∅ 66	∅
FEEDER 34	J134	∅ 67	∅
FEEDER 34	J234	∅ 68	∅
FEEDER 35	J135	∅ 69	∅
FEEDER 35	J235	∅ 70	∅
FEEDER 36	J136	∅ 71	∅
FEEDER 36	J236	∅ 72	∅
SPARE		∅ 73	∅
SPARE		∅ 74	∅
SPARE		∅ 75	∅
SPARE		∅ 76	∅

PFC TERMINALS

TB-104

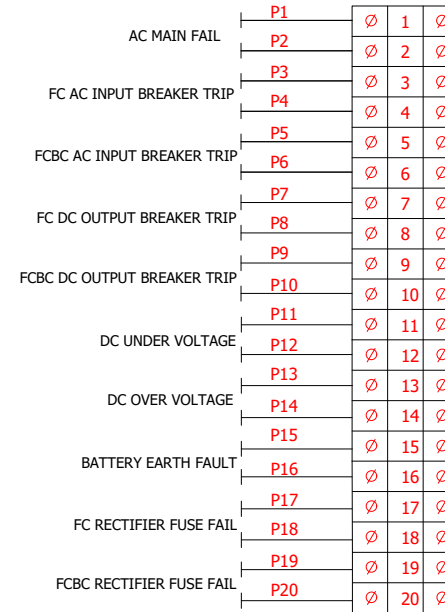

PFC TERMINALS

TB-104

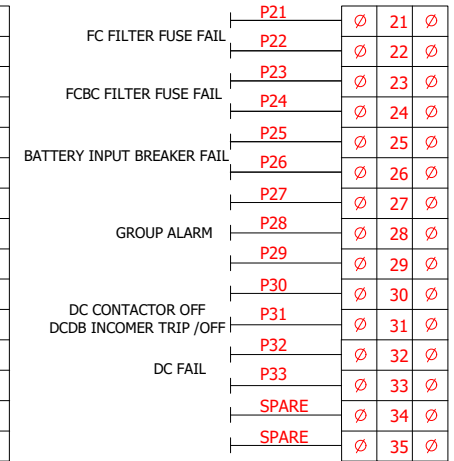

ANNUNCIATOR AC AUX SUPPLY TERMINALS

TB-107

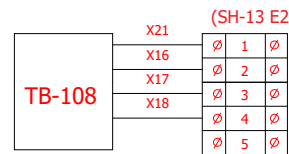
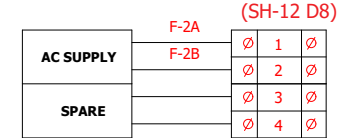

Chief Engineer/Projects

APTRANSCO/Vs/Vijayawada



GREEN SECURE ENERGY SYSTEMS,.

DRN	DP	SCALE	NTS
CHD	DP	DATE	26.06.2023
APPD	RJR	SHEET NO.	
DRAWING No.		15 OF 16	
APT STD	REV.	01	

ALL DIMENSIONS ARE IN MM UNLESS OTHERWISE SPECIFIED.

TITLE PAGE TYPE TERMINAL BLOCK DETAILS

220VDC / 200Ah, 22A FC & 25A FCBC WITH DCDB

01	26.06.2023	STANDARD DRAWING
00	21.06.2023	STANDARD DRAWING
REV	DATE	MODIFICATIONS

ALL INFORMATIONS CONTAINED IN THIS DOCUMENT IS CONFIDENTIAL AND COPYRIGHT THEREOF IS RESERVED BY GREEN SECURE ENERGY SYSTEMS, THEY SHALL NOT BE USED FOR ANY PURPOSE OTHER THAN FOR WHICH THEY ARE SUPPLIED AND SHALL NOT BE COPIED OR REPRODUCED WITHOUT WRITTEN PERMISSION.

NOTE: 1. DRAWING APPROVAL SUBJECT TO VALID TYPE TEST

REPORTS, TO BE CHECKED DURING ACCEPTANCE TESTS
2. FOR EPC CONTRACTS ONLY

BATTERY CHARGER

TERMINAL GROUP	CABLE SIZE	TYPE	CABLE SIZE
TB-101	Wire Range:1.5 - 35 Sq.mm Current (A):125A Voltage (V):1000V	STUD TYPE	U10-AWG POWER CABLE
TB-102	Wire Range:6.0 - 70 Sq.mm Current (A):192A Voltage (V):1000V	STUD TYPE	U8-AWG POWER CABLE
TB-103	Wire Range:1.5 - 10 Sq.mm Current (A):57A Voltage (V):1000V	STUD TYPE	4 Sq.mm (20A FEEDER) 2.5 Sq.mm (10A FEEDER)
TB-104	Wire Range:0.2 - 4.0 Sq.mm Current (A):32A Voltage (V):1000V	SCREW TYPE	1.5 Sq.mm
TB-105	Wire Range:0.2 - 4.0 Sq.mm Current (A):32A Voltage (V):1000V	SCREW TYPE	1.5 Sq.mm
TB-106	Wire Range:0.2 - 4.0 Sq.mm Current (A):32A Voltage (V):1000V	SCREW TYPE	1.5 Sq.mm
TB-107	Wire Range:0.2 - 4.0 Sq.mm Current (A):32A Voltage (V):1000V	SCREW TYPE	1.5 Sq.mm
TB-108	Wire Range:0.2 - 4.0 Sq.mm Current (A):32A Voltage (V):1000V	SCREW TYPE	1.5 Sq.mm

Chief Engineer/Projects
APTRANSCO/VS/Vijayawada.

OWNER APTRANSCO



GREEN SECURE ENERGY SYSTEMS,.

DRN	DP	SCALE	NTS
CHD	DP	DATE	26.06.2023
APPD	RJR	SHEET NO.	
DRAWING No.		16 OF 16	
APT STD		REV.	01

TITLE

220VDC / 200Ah, 22A FC & 25A FCBC WITH DCDB

PAGE TYPE

TERMINAL BLOCK DETAILS

ALL DIMENSIONS ARE IN MM UNLESS OTHERWISE SPECIFIED.

01	26.06.2023	STANDARD DRAWING
00	21.06.2023	STANDARD DRAWING
REV	DATE	MODIFICATIONS

ALL INFORMATIONS CONTAINED IN THIS DOCUMENT IS CONFIDENTIAL AND COPYRIGHT THEREOF IS RESERVED BY GREEN SECURE ENERGY SYSTEMS, THEY SHALL NOT BE USED FOR ANY PURPOSE OTHER THAN FOR WHICH THEY ARE SUPPLIED AND SHALL NOT BE COPIED OR REPRODUCED WITHOUT WRITTEN PERMISSION.

NOTE: 1. DRAWING APPROVAL SUBJECT TO VALID TYPE TEST
REPORTS, TO BE CHECKED DURING ACCEPTANCE TESTS
2. FOR EPC CONTRACTS ONLY

Drawing approval subject to valid vendor registration

 Bill of Material- Battery Charger with Integral DCDB					
SL.NO	PART ID	DESCRIPTION	TYPE/RATING	MAKE	QTY
1	PANEL ENCLOSURE	Cubicle, Free standing, Floor Mounting, Hinged type front & back doors with 3 point lock arrangement.	Dimension : H :1600 W:1300 D:800 (HxWxD in mm) Paint Finish : To 631 OF IS-5 ,Protection : IP-42 Base Frame : RAL 9005, Black	MJN /HD SHEET METAL	1
2	ANN	ANNUNCIATOR	16 WINDOW(INBUILT HOOTER) with RS-485	SECO / MINLEC	1
3	BLR2, BLR4	BLEEDER RESISTOR	RATING: 1K ohm, 100W	NANDALALA	2
4	BLR1, BLR3	BLEEDER RESISTOR	RATING: 2K ohm, 100W	NANDALALA	2
6	BB	BUS BAR	SIZE: 25 X 6 Sqmm TINNED COPPER	GREEN SECURE	1
7	CT 1-3	CURRENT TRANSFORMER	RATING:50/5A CLASS 1BURDEN:1.5VA	REPUTED	3
8	CC PCB	CONTROL CIRCUIT PCB	POT PANEL MOUNT 20K	GREEN SECURE	1
9	CC PCB	CONTROL CIRCUIT PCB	TYPE: GSSCB02B-2	GREEN SECURE	1
10	CC PCB	CONTROL CIRCUIT PCB	TYPE: GSSCB02B-3	GREEN SECURE	1
11	D1 TO D5	DIODE MODULE	RATING: 100A	SEMIKRON / NAINA / RUTTONSHA	5
12	DC PCB	BATTERY CURRENT LIMITER PCB	TYPE:GSS-BCL-20	GREEN SECURE	1
13	DLS	DOOR LIMIT SWITCH	RATING: 230VAC, 6A, 1C/O,	SURAJ	2
14	EF	EARTH FAULT	TYPE:GSS-06	GREEN SECURE	1
15	FFR1	FUSE FAILURE RELAY	TYPE:GSS-0718-1A	GREEN SECURE	1
16		FUSE FAILURE RELAY	TYPE:GSS-0718-1B	GREEN SECURE	1
17		FUSE FAILURE RELAY	TYPE:GSS-0718-1C	GREEN SECURE	1
18		FUSE FAILURE RELAY	TYPE:GSS-0718-1D	GREEN SECURE	1
19	FFR2	FUSE FAILURE RELAY	TYPE:GSS-0718-2A	GREEN SECURE	1
20		FUSE FAILURE RELAY	TYPE:GSS-0718-2B	GREEN SECURE	1
21		FUSE FAILURE RELAY	TYPE:GSS-0718-2C	GREEN SECURE	1
22		FUSE FAILURE RELAY	TYPE:GSS-0718-2D	GREEN SECURE	1
23	AC MAILS FAILS	AC MAILS FAILS	TYPE:GSS-08	GREEN SECURE	1
24		FC FILTER FUSE FAIL	TYPE:GSS-09-A	GREEN SECURE	1
25		FC FUSE FAIL	TYPE:GSS-09-B	GREEN SECURE	1
26		FCBC FILTER FUSE FAIL	TYPE:GSS-10-A	GREEN SECURE	1
27		FCBC FUSE FAIL	TYPE:GSS-10-B	GREEN SECURE	1
28	GRP ALARM	GROUP ALARM	TYPE:GSS-11	GREEN SECURE	1
29	FILTER	MESH FILTER	7"	POWERMATT / ELECTROD	2
30	FAN1-FAN2	COOLING FAN	RATING: 230V AC 6"	HICOOL	2
31	FC1, FC2	FILTER CAPACITOR	RATING: 4700µF/350V DC	ALCON / SARADA	2
32	K1	AC CONTACTOR	22A 3P ,COIL : 230V AC, AC3 DUTY	ABB/L&T/C&S/SIEMENS/SCHNEIDER	1
33	OLR-1	OVER LOAD RELAY	RATING :12.5... 18A	ABB/L&T/C&S/SIEMENS/SCHNEIDER	1

Chief Engineer/Projects
APTRANSCO/VS/Vijayawada.

NOTE: 1. DRAWING APPROVAL SUBJECT TO VALID TYPE TEST
REPORTS, TO BE CHECKED DURING ACCEPTANCE TESTS
2. FOR EPC CONTRACTS ONLY

34	K2	AC CONTACTOR	22A 3P ,COIL : 230V AC, AC3 DUTY	ABB/L&T/C&S/SIEMENS/SCHNEIDER	1
35	OLR-2	OVER LOAD RELAY	RATING :17 ... 24A	ABB/L&T/C&S/SIEMENS/SCHNEIDER	1
36	K3	DC CONTACTOR	32A 3P ,COIL : 220V DC 1 NO + 1NC	ABB/L&T/C&S/SIEMENS/SCHNEIDER	1
37	K3 ON	DC CONTACTOR ON	TYPE:GSS-07	ABB/L&T/C&S/SIEMENS/SCHNEIDER	1
38	L - 11	FC INDUCTOR(CHOKE)	RATING : 150V DC 25A,Inductance : 4mH	ABB/L&T/C&S/SIEMENS/SCHNEIDER	1
39	L - 21	FCBC INDUCTOR(CHOKE)	RATING : 150V DC 40A,Inductance : 4mH	ABB/L&T/C&S/SIEMENS/SCHNEIDER	1
40	L1,L2,L3	CLUSTER LED LAMP INDICATIONS	RATING: 230V AC, COLOR: RYB, YELLOW,BLUE	JIGO / SIEMENS / TEKNIC	1set
41	L4,L5,L6	CLUSTER LED LAMP INDICATIONS	RATING: 220V DC, COLOR: RED	JIGO / SIEMENS / TEKNIC	3
42	DCBD &H1-36	CLUSTER LED LAMP INDICATIONS	RATING:5mm RED	JIGO / SIEMENS / TEKNIC	36
43	M1	AC VOLTMETER	Input : 0-500V AC 3Ph,Auxiliary : 80-300V AC,Class :1, 96*96, Digital Type	ELMEASURE /EIC/MULTISPAN	1
44	M2,M3,M4 &M5	MULTIFUNCTION METER	Input : 0-300V DC Range : 0-100A Auxiliary : 80-300V AC/DC Class :1,96*96, Digital Type	ELMEASURE /EIC/MULTISPAN	4
45	M6	EARTH LEAKAGE METER	Range :100ma-0-100ma ,Class : 0.5, Size : 96*96,Type : Analog	ELMEASURE /EIC/MULTISPAN	1
46	PR	PROTECTIVE RELAY	Over / Under VoltagePhase (Failure, Sequence):2C/O	SELEC	1
47	P1-P7	POTENTIO METER	POT PANEL MOUNT 20K	GREEN SECURE	7
48	CB-100A	CHARGER ON/OFF Breaker	6A AC, 3P MCB	ABB/L&T/C&S/SIEMENS/SCHNEIDER	1
49	CB-100B	FAN1 BREAKER	2A AC, 2P MCB	ABB/L&T/C&S/SIEMENS/SCHNEIDER	1
50	CB-100C	FAN2 BREAKER	2A AC, 2P MCB	ABB/L&T/C&S/SIEMENS/SCHNEIDER	1
51	CB-100D	THERMOSTAT BREAKER	6A AC, 2P MCB	ABB/L&T/C&S/SIEMENS/SCHNEIDER	1
52	CB-100E	BREAKER FOR SWITCH BOARD(6A)	6A AC, 2P MCB	ABB/L&T/C&S/SIEMENS/SCHNEIDER	1
53	CB-101	FC INPUT BREAKER	20A 3P MCCB	ABB/L&T/C&S/SIEMENS/SCHNEIDER	1
54	CB-102	FCBC INPUT BREAKER	20A 3P MCCB	ABB/L&T/C&S/SIEMENS/SCHNEIDER	1
55	CB-103	FC OUTPUT BREAKER	32A 3P MCCB	ABB/L&T/C&S/SIEMENS/SCHNEIDER	1
56	CB-104	FCBC OUTPUT BREAKER	32A 3P MCCB	ABB/L&T/C&S/SIEMENS/SCHNEIDER	1
57	CB-105	BATTERY BREAKER	100A 3P MCCB	ABB/L&T/C&S/SIEMENS/SCHNEIDER	1
58	CB-106	DCDB INCOMER BREAKER	100A 3P MCCB	ABB/L&T/C&S/SIEMENS/SCHNEIDER	1
59	FEEDERS	FDR 1-12	20A DC, 2P MCB	ABB/L&T/C&S/SIEMENS/SCHNEIDER	12
60	FDR	FDR 13-36	10A DC, 2P MCB	ABB/L&T/C&S/SIEMENS/SCHNEIDER	24
62	R1-R2	Resistor	RESISTOR-2.5K-25W	NANDALALA	2
63	R3	Resistor	RESISTOR-1K-25W	NANDALALA	1
64	SC PCB	SNUBBER CIRCUIT PCB	TYPE:GSS-05	GREEN SECURE	1
65	SW1	SELECTOR SWITCH(LOCK & KEY TYPE)	25A 1P 2WAY	SALZER	1
66	SW2	SELECTOR SWITCH	25A 4P 4WAY	SALZER	1
67	SHUNT 1-2	SHUNT	RATING: 50A/75mV	KEW / MECO/RISHAB	2
68	SHUNT 3-4	SHUNT	RATING: 100A/75mV	KEW / MECO/RISHAB	2
69	SC	AC SOCKET WITH SWITCH	RATING: 230V, 6A	ANCHOR / GM	1
70	SF1 TO SF3	SEMICONDUCTOR FUSES WITH BASE	RATING: 32A	BUSSMAN	3
71	SF4 TO SF6	SEMICONDUCTOR FUSES WITH BASE	RATING: 40A	BUSSMAN	3
72	F1	HRC FUSE LINKS	RATING: 32A	BUSSMAN	1

Chief Engineer/Projects
APTRANSCO/VS/Vijayawada.

NOTE: 1. DRAWING APPROVAL SUBJECT TO VALID TYPE TEST
REPORTS, TO BE CHECKED DURING ACCEPTANCE TESTS
2. FOR EPC CONTRACTS ONLY

73	F2	HRC FUSE LINKS	RATING: 32A	BUSSMAN	1
74		BASE FOR FUSE LINKS	RATING: 32A	BUSSMAN	1
75		BASE FOR FUSE LINKS	RATING: 40A	BUSSMAN	1
76	TRF-1	TRANSFORMER-FC	KVA RATING : 8 KVA, PRI : 415V +/-15% 50Hz ,SEC : 242V 50Hz,TYPE : DELTASTAR	REPUTED	1
77	TRF-2	TRANSFORMER	RATING : 10VA, PRI : 242V +/-15% 50Hz 1Ph+N,SEC : 20V-0-20V	REPUTED	1
78	TRF-3	TRANSFORMER	RATING : 10VA, PRI : 242V +/-15% 50Hz 1Ph+N,SEC : 24V-0-24V	REPUTED	1
79	TRF 4,5,6	TRANSFORMER	RATING : 10VA, PRI : 140V +/-15% 50Hz 1Ph+N,SEC : 24V-0-24V	REPUTED	3
80	TRF-7	TRANSFORMER-FCBC	KVA RATING : 10 KVA,PRI : 415V +/-15% 50Hz,SEC : 280V 50Hz,TYPE : DELTASTAR	REPUTED	1
81	TRF-8	TRANSFORMER	RATING : 10VA, PRI : 280V +/-15% 50Hz 1Ph+N,SEC : 20V-0-20V	REPUTED	1
82	TRF-9	TRANSFORMER	RATING : 10VA, PRI : 280V +/-15% 50Hz 1Ph+N,SEC : 24V-0-24V	REPUTED	1
83	TRF 10,11,12,13	TRANSFORMER	RATING : 10VA, PRI : 160V +/-15% 50Hz 1Ph+N,SEC : 24V-0-24V	REPUTED	4
84	TH1-TH3	THYRISTOR MODULE(SCR1A-6A)	RATING: 100A/1600 PIV (with Heat sink 150mm)	SEMIKRON / NAINA / RUTTONSHA	3
85	TH4-TH6	THYRISTOR MODULE(SCR1B-6B)	RATING: 100A/1600 PIV (with Heat sink 150mm)	SEMIKRON / NAINA / RUTTONSHA	3
86	TC PCB	TRIGGERING CIRCUIT PCB	TYPE: GSSTB-01A-1	GREEN SECURE	1
87	TC PCB	TRIGGERING CIRCUIT PCB	TYPE: GSSTB-01A-2	GREEN SECURE	1
88	TD1	Transducer	Input : 0-75mA,Auxiliary : 80-276 V AC/DC,Output : 4-20mA	SECURE / RISHABH	1
89	X-1	AC I/P TERMINALS	CSTSN6U-35mm ² M6 STUD NUT DRIVER OPERATED TB	CONNECTWELL	5
90	X-2	BATTERY TERMINALS	CBB70-70 mm ² FD THRU BOLT/NUT TERMINAL BLOCK	CONNECTWELL	4
91	X-3	FEEDER TERMINALS	CSTSN6U-35mm ² M6 STUD NUT DRIVER OPERATED TB	CONNECTWELL	50
92	X-4	PFC TERMINALS	CTS4UN,4 mm ² FEED THRU SCREW CLAMP TERMINAL	CONNECTWELL	35
93	X-5	RS-485 TERMINALS	CTS4UN,4 mm ² FEED THRU SCREW CLAMP TERMINAL	CONNECTWELL	12
94	X-6	TRANSDUCER TERMINALS	CTS4UN,4 mm ² FEED THRU SCREW CLAMP TERMINAL	CONNECTWELL	4
95	X-7	AC AUX SUPPLY OF ANNUNCIATOR	CTS4UN,4 mm ² FEED THRU SCREW CLAMP TERMINAL	CONNECTWELL	4
96	X-8	ANNUNCIATOR TERMINALS	CTS4UN,4 mm ² FEED THRU SCREW CLAMP TERMINAL	CONNECTWELL	5
97		END PLATE		CONNECTWELL	16
98		MARKER PRINTED		CONNECTWELL	8

Drawing approval subject to valid vendor registration

Chief Engineer/Projects
APTRANSCO/VS/Vijayawada.