



NOTE: 1. Drawings Approval subject to valid type test reports, to be checked during

acceptance tests.  
2. For EPC contractors only.

NOTES :-

1. MAKE OF BUSHING: IEC/MODERN/ABL/BHEL/CJI
2. ALL FERROUS PARTS EXPOSED TO THE ATMOSPHERE SHALL BE PAINTED WITH P.U. PAINT SHADE 631 OF IS:5
3. ALL HARDWARE SHALL BE HOT DIP GALVANIZED.
4. ALL GASKETS SHALL BE FIXED IN PROPERLY MACHINED GROOVES.
5. ALL GASKETS SHALL BE MADE OF NITRILE BUTYL RUBBER.
6. TRANSFORMER OIL AS PER IEC : 60296.
7. PRIMARY WINDING SHALL BE BAR TYPE.
8. SECONDARY SHALL BE TOTALLY ENCASED IN RIGID METALLIC SHELL.
- \* QUANTITY OF OIL :- 90 LITRES APPROX.
- \* TOTAL WEIGHT OF CT :- 350 kg. APPROX.
- \* TOTAL CREEPAGE DISTANCE:- 4495 mm. MINIMUM

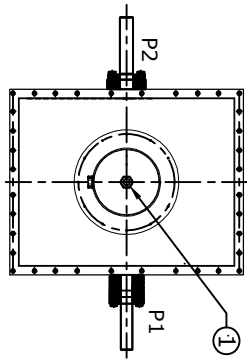

675 ± 75

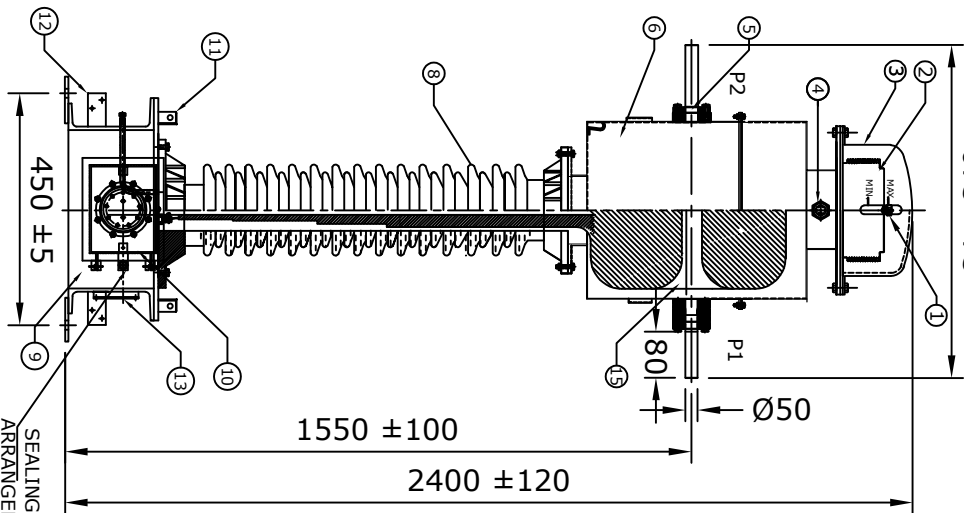

Drawing approval subject to valid vendor registration

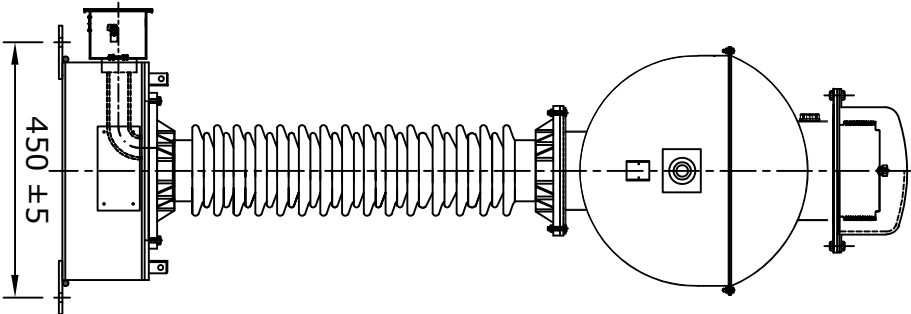

S.No.	DESCRIPTION	MATERIAL	QTY
1	OIL FILLING PORT	M.S	1
2	BELLOW	S.S	1
3	BELLOW DOME	M.S/AL.	1
4	OIL LEVEL INDICATOR	BRASS/AL.	1
5	PRIMARY TERMINAL	ALUMINIUM	2
6	OIL TANK WITH COVER	M.S	1
7	SECONDARY TERMINAL	BRASS	---
8	BUSHING	PORCELAIN	1
9	BASE	M.S	1
10	SECONDARY TERMINAL BOX	M.S	1
11	LIFTING HOOK	M.S	4
12	EARTHING FLAT 80X50X8THICK.	M.S	2
13	NAME AND RATING PLATE	ALUMINIUM	1
14	MOUNTING HOLE, Ø16mm±2	M.S	4
15	OIL DRAIN PLUG	M.S	1

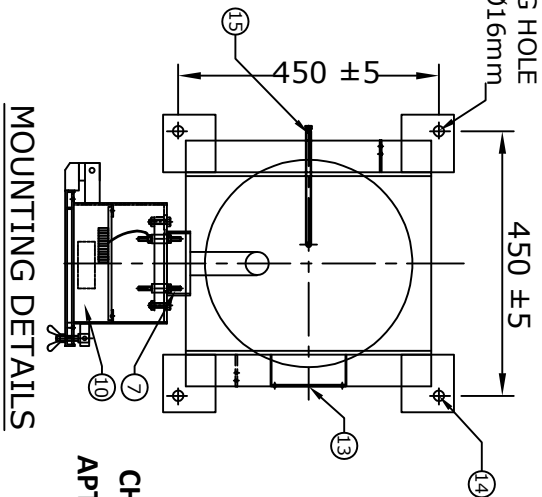

MOUNTING DETAILS

CHIEF ENGINEER/PROJECTS  
APTRANSCO/VS/VIJAYAWADA

RATIO : 500-600-800/1-1A, 300-500-600-800/1A

UNLESS OTHERWISE SPECIFIED  
1. ALL DIMENSIONS ARE IN mm  
2. TOLERANCE WHEREVER NOT INDICATED: ±5%

DATE	NAME	MATERIAL
DGN 13.07.2023	SFS	
DRN 13.07.2023	AKASH	SEE TABLE
CHD 13.07.2023	BLS	

DATE	NAME	MATERIAL
DGN 13.07.2023	SFS	
DRN 13.07.2023	AKASH	SEE TABLE
CHD 13.07.2023	BLS	

TITLE

SECTIONAL ARRANGEMENT DRAWING  
FOR 132kV CURRENT TRANSFORMER

SCALE



DRG:NO ME-132CT-SE-01

REV.	REVISION DESCRIPTION	DATED INITIALS
R0	FOR APPROVAL	13.07.2023

DATE	NAME	MATERIAL
DGN 13.07.2023	SFS	
DRN 13.07.2023	AKASH	SEE TABLE
CHD 13.07.2023	BLS	



MEHRU ELECTRICAL & MECHANICAL  
ENGINEERS PVT. LIMITED

NOTE: 1. Drawings Approval subject to valid type test reports, to be checked during acceptance tests.

2. For EPC contractors only.

Drawing approval subject to valid vendor registration

# MEHRU LIVE TANK CURRENT TRANSFORMER

MADE TO IS: 16227

HIGHEST SYSTEM VOLTAGE	145 kV	INSULATION LEVEL	275/650 kV
RATED S.T.C	31.5kA for 1 second	RATED FREQUENCY	50 Hz
NOMINAL SYSTEM VOLTAGE	132 kV	CORE 1	CORE 2
		CORE 1	CORE 3
RATIO	PRIMARY(Amp)	500-600-800	500-600-800
	SECONDARY(Amp)	1	1
SECONDARY TERMINALS	IS1-1S2-1S3-1S4	2S1-2S2-2S3-2S4	3S1-3S2*-3S2-3S3-3S4
RATED BURDEN IN V/A	----	20 VA	10 VA
ACCURACY CLASS	PX/0.5 @5VA	5P	0.2S
ALF / ISF	----	20	≤5 @ All Ratio
Min Knee point voltage	500/600/800 V	----	----
Max Rct @ 75° C	2.5/3/4 Ω	----	----
Max text @ V/k	60/50/37.5 mA	----	----
YEAR OF MANUFACTURE	2023	SERIAL NO.	----

RATED CONTINUOUS THERMAL CURRENT: 120% OF THE RATED PRIMARY CURRENT

\* QUANTITY OF OIL :- 90 LITRES APPROX., \* TOTAL WEIGHT OF CT :- 350 kg. APPROX.

\* TOTAL CREEPAGE DISTANCE :- 4495 mm. MINIMUM

MADE IN INDIA BY

**MEHRU ELECTRICAL AND MECHANICAL ENGINEERS (P) LTD.**

SP-2/180, RIICO INDUSTRIAL AREA, KEHRANI, BHIWADI - RAJASTHAN - 301019

225 ±25

## SUITABLE FOR HOT LINE WASHING CONNECTION DIAGRAM

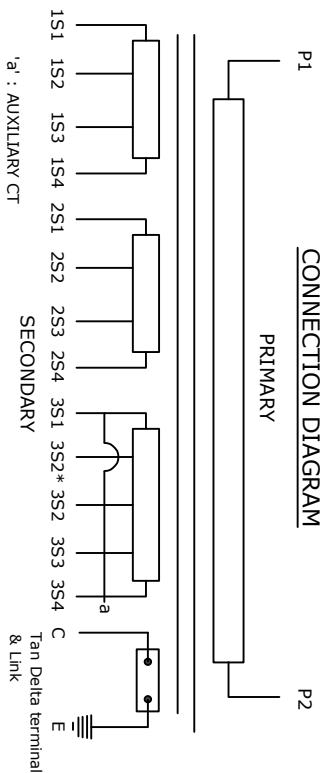

105 ±15

FOR RATIO	PRIMARY CONNECTION	SECONDARY CONNECTION	CORE I	CORE II	CORE III
300/1A	P1 - P2	-----	-----	-----	3S1-3S2* Short 3S2*-a
500/1A	P1 - P2	IS1-1S2	2S1-2S2	3S1-3S2	Short 3S2-a
600/1A	P1 - P2	IS1-1S3	2S1-2S3	3S1-3S3	Short 3S3-a
800/1A	P1 - P2	IS1-1S4	2S1-2S4	3S1-3S4	Short 3S4-a

**CAUTION**  
 I. SHORT CIRCUIT AND EARTH ALL SECONDARY TERMINALS ARE NOT IN USE.  
 II. ALWAYS KEEP TAN DELTA TESTING TERMINAL 'C' SHORTED TO EARTH DURING OPERATION.  
 III. DO NOT REMOVE EARTH LINK WHEN IN OPERATION.

- NOTES:-
- MATERIAL OF NAME PLATE : ALUMINIUM ANODIZED
  - THICKNESS OF NAME PLATE : 1.2 mm.
  - SERIAL NO. SHALL BE ENGRAVED BEFORE DISPATCH.
  - 5VA BURDEN OF DUAL CORE CLASS IS FOR 0.5 ACCURACY CLASS.
  - FACTORY ACCEPTANCE TEST SHALL BE DONE FOR CORE 1 FOR PX & 0.5 AT 5VA

- Minimum 300mm plinth shall be maintained for CT/PT/CVT/Isolators/IV/LA/Breakers in the substation during foundation works to ensure safe live to ground clearance per IE rules.
- Since the supply of terminal connectors is not in the scope of manufacturer as mentioned in the drawings. The EPC contractor shall be instructed to supply the same live with CT/PT/CVT/Isolator/IV/LA/Breaker's requirement and compatibility.

RATIO : 500-600-800/1-1A, 300-500-600-800/1A

UNLESS OTHERWISE SPECIFIED  
 1. ALL DIMENSIONS ARE IN mm  
 2. TOLERANCE WHEREVER NOT INDICATED: ±5%

DATE	NAME	MATERIAL
13.07.2023	SPS	AL. ANODIZED
13.07.2023	AKASH	
13.07.2023	BLS	

CHIEF ENGINEER/PROJECTS

APTRANSCO/VS/VIJAYAWADA

REV.	REVISION DESCRIPTION	DATED INITIALS
R0	FOR APPROVAL	13.07.2023

TITLE	SCALE
NAME PLATE DRAWING FOR 132KV CURRENT TRANSFORMER	N.T.S

DRG.NO ME-132CT-NP-01

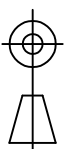

NOTE: 1. Drawings Approval subject to valid type test reports, to be checked during acceptance tests.

2 For EPC contractors only

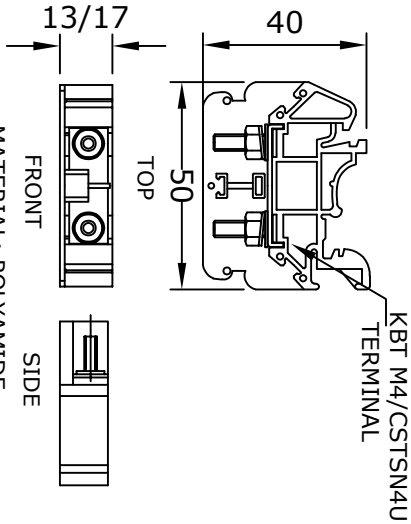
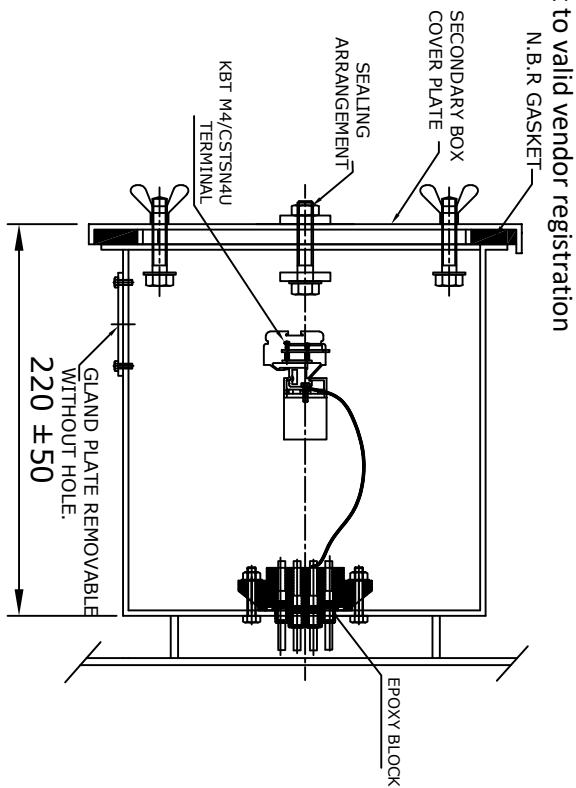
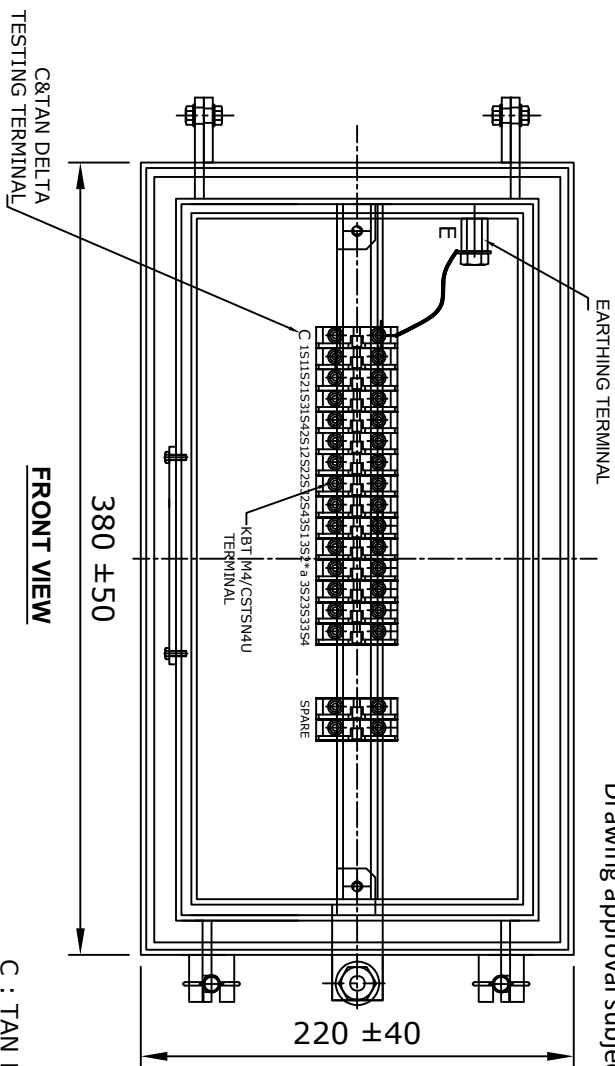

MAKE: ELMEX/CONNECTWELL  
MATERIAL: POLYAMIDE  
**TERMINAL (DETAIL)**

- NOTES:-**
1. SECONDARY TERMINAL BOX SHALL BE PROVIDED WITH REMOVABLE GLAND PLATE WITHOUT HOLE.
  2. SECONDARY TERMINAL BOX SHALL BE PROVIDED WITH COVER.
  3. SHEET THICKNESS FOR TERMINAL BOX SHALL BE 3.0mm & FOR COVER 2.0mm.
  4. MATERIAL OF GASKET : NITRILE BUTYL RUBBER GASKET.
  5. DEGREE OF PROTECTION : IP 55
  6. 20% SPARE TERMINAL SHALL BE PROVIDED.

Drawing approval subject to valid vendor registration

REV.	FOR APPROVAL	DATED
R0		13.07.2023
	REVISION DESCRIPTION	INITIALS

RATIO : 500-600-800/1-1A, 300-500-600-800/1A  
UNLESS OTHERWISE SPECIFIED  
1. ALL DIMENSIONS ARE IN mm  
2. TOLERANCE WHEREVER NOT INDICATED: ±5%

UNLESS OTHERWISE SPECIFIED	DATE	NAME	MATERIAL
DGN.	13.07.2023	SPS	M.S
DRN.	13.07.2023	AKASH	
CHD.	13.07.2023	BIS	

**CHIEF ENGINEER/PROJECTS**  
**APTRANSCO/VS/VIJAYAWADA**

TITLE	SCALE
SECONDARY TERMINAL BOX DRG. FOR 132KV CURRENT TRANSFORMER	N.T.S
DRG.NO	
ME-132CT-STB-01	

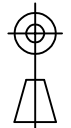

MEHRU ELECTRICAL & MECHANICAL ENGINEERS PVT. LIMITED

NOTE: 1. Drawings Approval subject to valid type test reports, to be checked during acceptance tests.

2.For EPC contractors only.

Guaranteed Technical Particulars for 132kV Current Transformer			
Sl. No.	Item Description	Unit	
<b>E</b>	<b>CURRENT TRANSFORMER</b>		
1	Make		Mehru Electrical & Mechanical Engineers (P) Ltd, Bhiwadi, (Raj), Inida
2	Type and Designation		Outdoor, Oil Cooled Live Tank Type, Current Transformer
3	Applicable standards		IS 16227
4	Class		A
5	Rated Voltage	132 kV	132 kV
6	Rated Primary current	Amps	500-600-800A,300-500-600-800
7	Rated Secondary current	Amps	1
8	Rated output (Burden)	VA	Core 2: 20VA, Core:3: 10VA,
9	Rated output at 0.8 lag. p.f.	VA	N/A
10	Class of accuracy		Core:1 - PX/0.5@5VA, Core: 2 - 5P, Core:-3: 0.2S
11	Accuracy limit factor		Core2: 20
12	Knee point voltage	Volts	Core:1: 500/600/800 V
13	CT Resistance of secondary winding corrected to 75 deg.C	Ohms	Core-1: 2.5/3/4
14	Magnetising current at knee-voltage point		Core-1: 60/50/37.5mA
15	secondary limiting voltage	kV	As per IS 16227
16	Instrument security factor for winding meant for metering		Core-3 : ≤ 5 at all taps
17	One minute Power Frequency withstand test voltage of		
a)	Primary winding	kV (rms)	275
b)	Secondary winding	kV (rms)	3
18	1.2/50Hz Impulse wave withstand voltage of primary winding	kV (peak)	650
19	One minute dry P.F. withstand voltage of primary winding	kV (rms)	275
20	Creepage distance	mm	31mm/kV i.e. 4495mm (Min.)
21	Rated continuous thermal current	Amps	120% of rated primary current
22	Ratios available at highest taps		Yes
23	Rated short time thermal current	kA (rms)	31.5 kA
24	Rated time for above	Sec.	1
25	Rated dynamic current for primary	kA (Peak)	78.75
26	Class of insulation		A
27	Max. Temperature rise over ambient of 50 deg.C at any part of oil	deg.C	50c max
28			
a)	Radio interference voltage		As per IS 16227 Clause 6.11.2 <2500uV
b)	Partial discharge level		<10 pC at Um & <5 pc at 1.2 Um/√3
29	Temp. rise after passing short time thermal current for one second	deg.C	50c max
30	Current density in primary winding at		
a)	Normal rating		0.40 Amp/sqmm (max)
b)	Short time rating of 1 Sec.		16.05 Amp/sqmm(max.)
c)	Dynamic rating		40.13 Amp/sqmm (max.)
31	Type of primary winding		Aluminium
32	No. of primary turns		1

Drawing approval subject to valid vendor registration

**CHIEF ENGINEER/PROJECTS**  
**APTRANSCO/VS/VIJAYAWADA**

NOTE: 1. Drawings Approval subject to valid type test reports, to be checked during acceptance tests.

2.For EPC contractors only.

33	Type of secondary winding		Copper
34	Radio interference voltage	(micro volts)	
a)	with terminal connector mountd		<2500uV
b)	under test condition		<2500uV
35	Mounting details		450±5 x 450±5 mm
36	Source/grade of oil and standard with which it complies		EHV Grade Transformer Oil as per IS 335 /IEC 60296 of any reputed make
37	Quantity of insulating oil	Litres	90 Ltr Approx
38	Weight of Oil	kg	72 kgs Approx
39	Total Weight including Oil	kg	350 kG Approx
40	Overall dimensions (mm)		2400±120 x 675±75 x 450±5 mm
41	Wheather sealed (if so, type of sealing)		Yes, By SS BELLOW
42	Tan delta		<0.005
43	Height of supporting structure		Not in our scope of supply
44	Whether the following are enclosed with the tender		
a)	All type test reports		Yes
b)	Drawings as per the specification		Yes
c)	Technical literature for C.T.		Yes

1. Minimum 300mm plinth shall be maintained for CT/PT/CVT/Isolators/IV/LA/Breakers in the substation during foundation works to ensure safe live to ground clearance per IE rules.
2. Since the supply of terminal connectors is not in the scope of manufacturer as mentioned in the drawings. The EPC contractor shall be instructed to supply the same line with CT/PT/CVT/Isolator/IVT/LA/Breaker's requirement and compatibility.

**CHIEF ENGINEER/PROJECTS  
APTRANSCO/VISVIJAYAWADA**

Drawing approval subject to valid vendor registration