

# 145 KV CURRENT TRANSFORMER TYPE: IMB 145

CLIENT:  
**(AS APPLICABLE)**

END CUSTOMER:  
**APTRANSCO**

W.O. NO.:  
**(AS APPLICABLE)**

PROJECT:  
**(AS APPLICABLE)**

P.O. NO.:  
**(AS APPLICABLE)**

QTY.:  
**(AS APPLICABLE)**

CT RATIO:  
**600-300/1-1-1**

Drawing approval subject to valid vendor registration

SR. NO.	REFERENCE OF STD DRGS/ DOCUMENTS	REV.	DESCRIPTION
1.	1HYT903320-007	A	GENERAL ARRANGEMENT
2.	1HYT903320-008	B	RATING PLATE
3.	1HYT903320-009	B	SECONDARY TERMINAL BOX
4.	1HYT903320-010	B	MAGNETIZATION CURVE

**Chief Engineer/Construction**

NOTE : DRAWING APPROVAL SUBJECT TO VALID TYPE TEST REPORTS, TO BE CHECKED DURING ACCEPTANCE TESTS.

Prepared: SR	Checked: PDS	Approved: SN
Without Sep. PL.: <input type="checkbox"/>	SamePL.Same No.: <input type="checkbox"/>	Sep. PL.Other No.: <input type="checkbox"/>
Derived by:	Supersedes:	Supersedes by:
A 2021-01-11		
B 2021-01-21		

**LIST OF DOCUMENTS FOR IMB 145 TYPE CT**

**1HYT903320-006**

Scale NTS
T.Sh. 1
Sheets 1

We reserve all rights in this document and in the information contained there in Reproduction,use or disclosure to third parties without express authority is strictly forbidden ©ABB.

Ⓐ New drg. prepared.

Ⓑ change in sr no. 2,3,4

This drawing is a COMPUTER ORIGINAL and does not require signature for its authentication



Drawing approval subject to valid vendor registration

This drawing is a COMPUTER ORIGINAL and does not require signature for its authentication

Revision Details:  
A) New drg. prepared.

We reserve all rights in this document and in the information contained therein. Reproduction, use or disclosure to third parties without express authority is strictly forbidden. © ABB

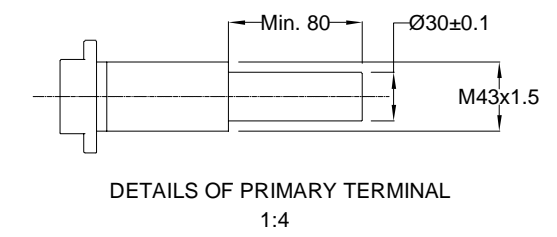
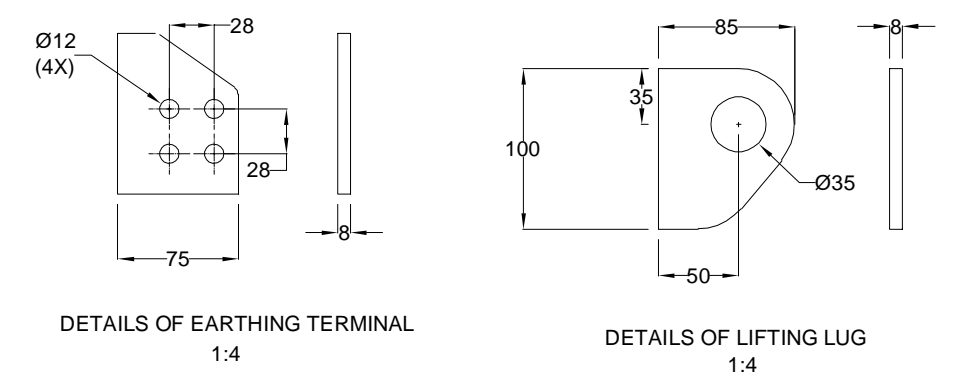
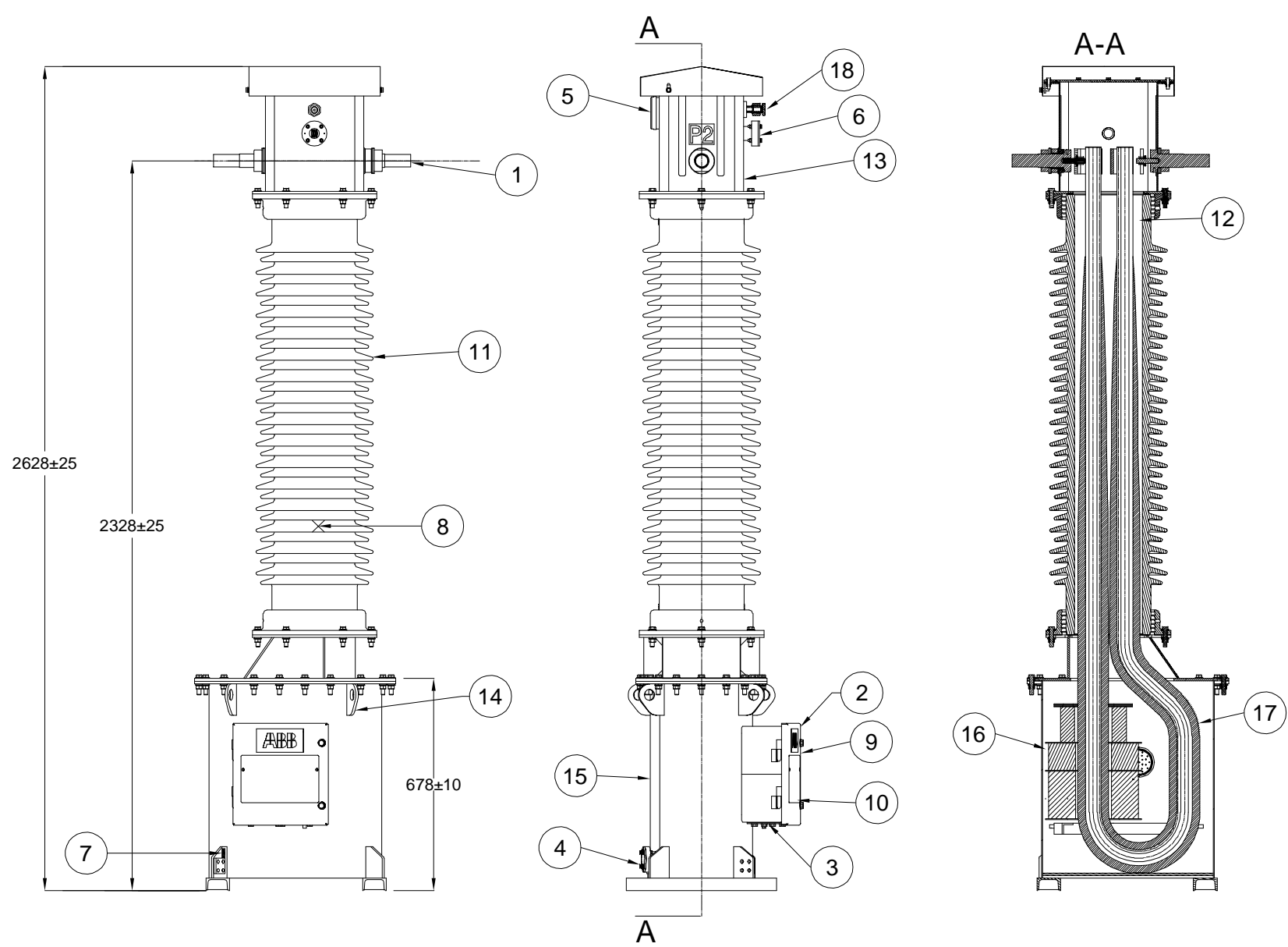

18	PRESSURE RELEASE DEVICE	1	S.S/BRASS
17	PRIMARY WINDING	1	PRIMARY CONDUCTOR (ALU.)
16	CORE STACK	1	-
15	BOTTOM TANK & TANK COVER	1	M.S HDG*
14	LIFTING LUG	4	M.S HDG*
13	TOP CHAMBER	1	M.S HDG*
12	TRANSFORMER OIL	~75 KG	EHV GRADE IEC 60296
11	INSULATOR	1	PORCELAIN
10	RATING PLATE	1	ALU.
9	D3 TERMINAL	1	INSIDE TERMINAL BOX
8	CENTRE OF GRAVITY	-	-
7	EARTH CLAMP	2	S.S WELDED OVER M.S
6	OIL LEVEL INDICATOR	1	TOUGHENED GLASS
5	OIL & NITROGEN FILLING PLUG	1	M.S HDG*
4	OIL DRAIN PLUG WITH BLANKING PLATE	1	M.S HDG*
3	REMOVABLE GLAND PLATE	1	M.S HDG*
2	SECONDARY TERMINAL BOX	1	M.S HDG*
1	PRIMARY TERMINAL	2	ALU.
Sr No.	Item Description	Qty.	Material

\*HOT DIP GALVANIZED ON OUTER SURFACE AND PAINTED ON INNER SURFACE  
INNER SURFACE PAINTED WITH OIL RESISTIVE PAINT

TOTAL WEIGHT 550 kg. APPROX  
CREEPAGE DISTANCE 3625 mm  
ALL FERROUS PARTS EXPOSED TO  
ATMOSPHERE ARE HDG.

GENERAL TOLERANCE AS PER ISO:2768-C.

**NOTE : DRAWING APPROVAL SUBJECT TO VALID TYPE TEST REPORTS, TO BE CHECKED DURING ACCEPTANCE TESTS.**

**Chief Engineer/Construction**

Revision		OUTDOOR 145 kV CURRENT TRANSFORMER TYPE IMB 145	GENERAL ARRANGEMENT DRAWING (For CT with Small Tank)	Prepared: SR	Checked: PDS	Approved: SN	file: 3320-007	Total sh. 1
A	2021-01-11			ABB APPSIL			1HYT903320-007	Sh.No. 1

Drawing approval subject to valid vendor registration

250

**ABB** Current transformer      APPSIL      Production year - YYYY      Made in India

Serial number	nnnnnnn	Type	IMB 145	Frequency	50 Hz
Insulation level	145/275/650	Standard	IEC: 61869-1,2	Temperature range	-5 to +50 °C
Rated pri. normal current	600A	Total mass(Approx)	550 kg	Total creepage minimum	3625mm
Max continous primary current	720A	Insulation oil(Approx)	75 kg	Ith	31.5/1 kA/s
GA Drawing	1HYT903320-007	Suitable for Hot line washing	Yes	Idyn	78.75 kAp

RATIO	600/1	300/1
CORE-1	1S1-1S3	1S1-1S2
CORE-2	2S1-2S3	2S1-2S2
CORE-3	3S1-3S3	3S1-3S2
CORE-4	-	-
CORE-5	-	-

**AUX. REACTOR CONNECTION DETAIL FOR CORE 3 ONLY**

1.CONNECT SHORTING LINK BETWEEN 1X1-3S1 & 1X2-3S3 FOR THE RATIO OF 600/1 RESPECTIVELY. TAKE OUTPUT FROM 1X1-1X2.

2.DO NOT CONNECT SHORTING LINK FOR THE RATIO OF 300/1 .

CORE	CORE-1	CORE-2	CORE-3	CORE-4	CORE-5
I A	600-300/1	600-300/1	600-300/1	-	-
Vk V/ B VA	20	>60(Rct+10)	20	-	-
CI	5P	PX	0.2S	-	-
ISF/ALF	20	-	<5	-	-
Io mA	-	<50/100 at Vk	-	-	-
Rct Ω	-	<6/3	-	-	-

END CUSTOMER: APTRANSCO
ABB WORKS ORDER NO: (AS APPLICABLE)
PROJECT: (AS APPLICABLE)
Caution 1)Ensure D3(Tan Delta) Bushing connection with Earth 2)Secondary terminals must be short circuited before burden is disconnected

Serial number nnnnnnn to be decided when manufactured  
 Production year yyyy = Actual year,date & month of Production  
 Material: Aluminium 2mm Thk.  
 Letter height 3 mm

**NOTE : DRAWING APPROVAL SUBJECT TO VALID TYPE TEST REPORTS, TO BE CHECKED DURING ACCEPTANCE TESTS.**

**Chief Engineer/Construction**

Revision		145 kV OUTDOOR CURRENT TRANSFORMER TYPE IMB 145	RATING PLATE	Prepared: SR	Checked: PDS	Approved: SN	File: 3320-008	Total sh. 1
A	2021-01-11			<b>ABB APPSIL</b>			<b>1HYT903320-008</b>	Sh.No. 1
B	2021-01-21							

This drawing is a COMPUTER ORIGINAL and does not require signatures for its authentication

Revision Details:  
 (B)Core-1 revised

Revision Details:  
 (A)New drg prepared.

We reserve all rights in this document and in the information contained there in. Reproduction, use or disclosure to third parties without express authority is strictly forbidden. © ABB.

NOTE : DRAWING APPROVAL SUBJECT TO VALID TYPE TEST REPORTS, TO BE CHECKED DURING ACCEPTANCE TESTS.

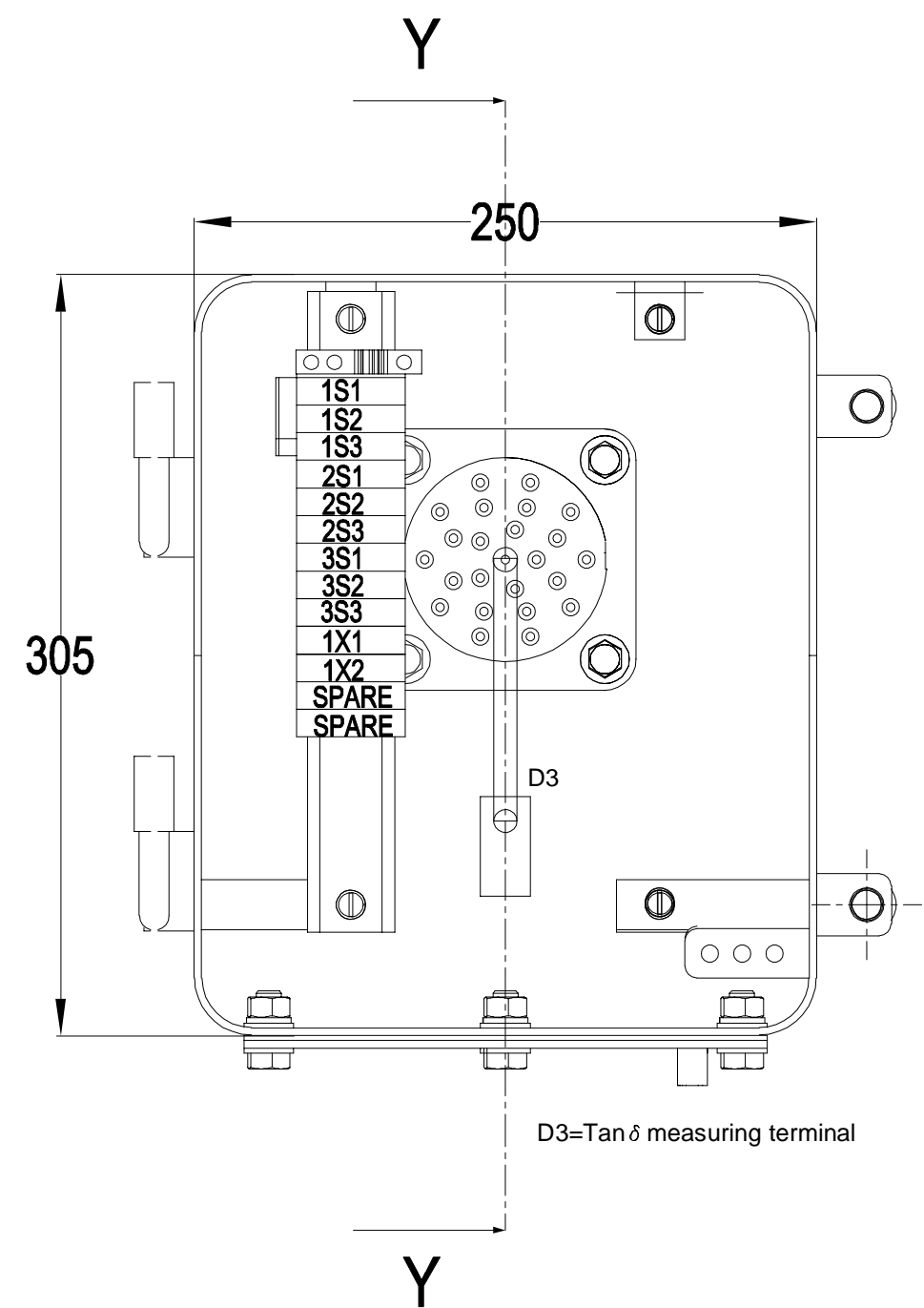
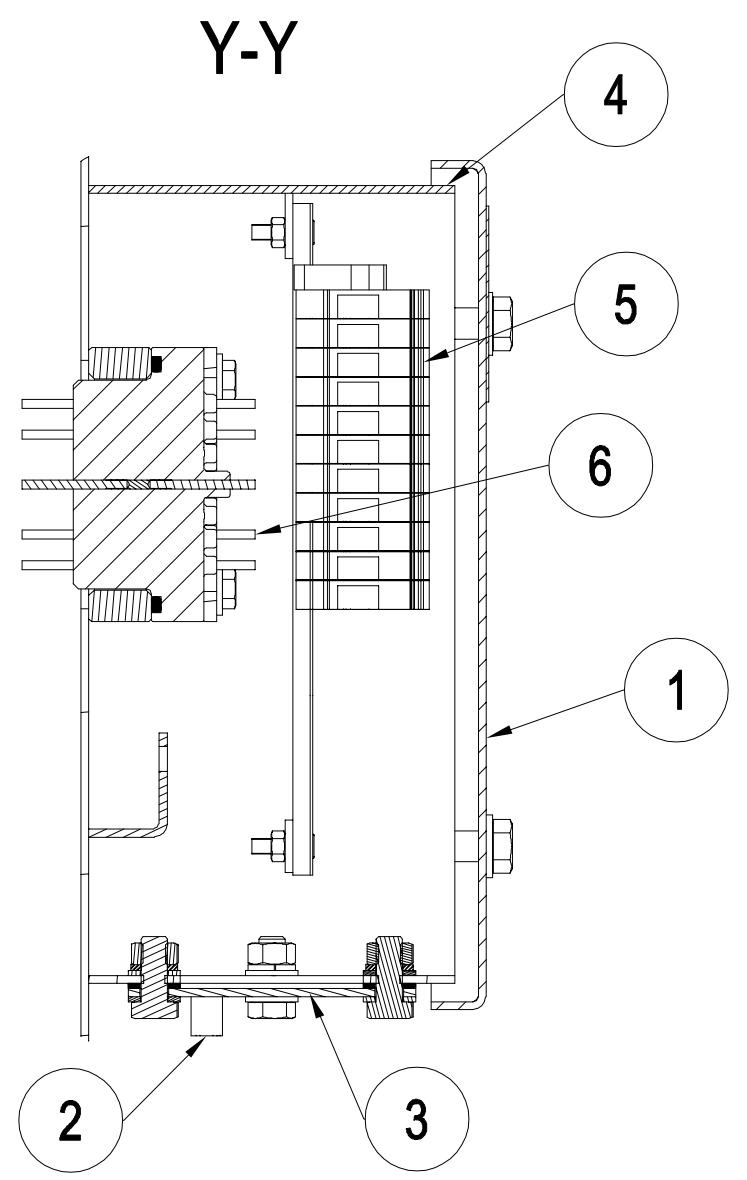

FOR CORE 3 ONLY

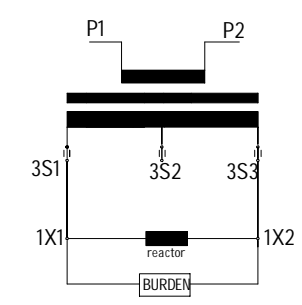

FOR RATION OF 600/1

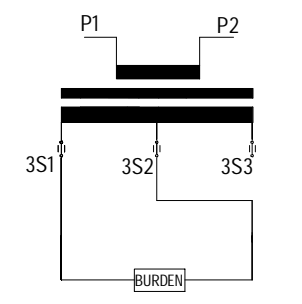

FOR RATIO OF 300/1

Revision Details:  
 (B) Gland plate thickness added  
 (A) New Drawing prepared  
 We reserve all rights in this document and in the information contained there in. Reproduction, use or disclosure to third parties without express authority is strictly forbidden. ©ABB.

**Chief Engineer/Construction**

NOTES :-  
 1) DEGREE OF PROTECTION IP 55  
 2) THE SECONDARY TERMINAL BOX IS HDG  
 3) D3 TERMINAL IS FOR THE MEASUREMENT OF POWER FACTOR AND LOSS ANGLE  
 4) THE BOX IS SUITABLE FOR ACCOMMODATING SECONDARY CABLES OF 1100 V  
 5) STEEL SHEET 3.15 mm THICK HOT ROLLED  
 6) ALL DIMENSIONS ARE IN mm. GENERAL TOLERANCE AS PER ISO: 2768-c  
 7) NO. OF WIRES SHOWN IN THE TERMINAL BLOCK ARE INDICATIVE ONLY

Drawing approval subject to valid vendor registration

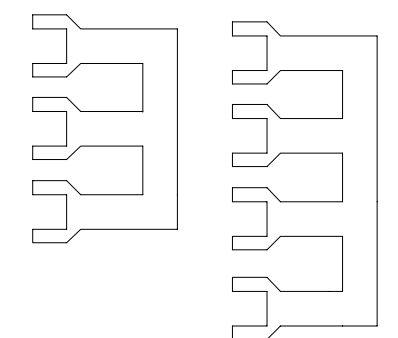

6	COPPER WIRE
5	SERIES TERMINAL STUD TYPE
4	EPDM GASKET
3	UNDRILLED GLAND PLATE (3mm Thk.)
2	DRAIN TUBE
1	COVER
SR NO	ITEM DESCRIPTION

Revision		CURRENT TRANSFORMER TYPE : IMB 145 SEC. TERMINAL BOX : DETAILS	DRAWN: SR	CHECKED: PDS	APPRD.: SN	file: 3320-009	TOTAL SH. 1
A	2021-01-11		<b>ABB APPSIL</b>		<b>1HYT903320-009</b>		Sh. NO. 1
B	2021-01-21						

Item	Core	Current Ratio	Sec. Resistance At 75° C. Ohms	C1	C2
-	1	600/1	-	8.24	0.161
		300/1	-	4.12	0.322
	2	600/1	<6	9.90	0.161
		300/1	<3	8.04	0.322

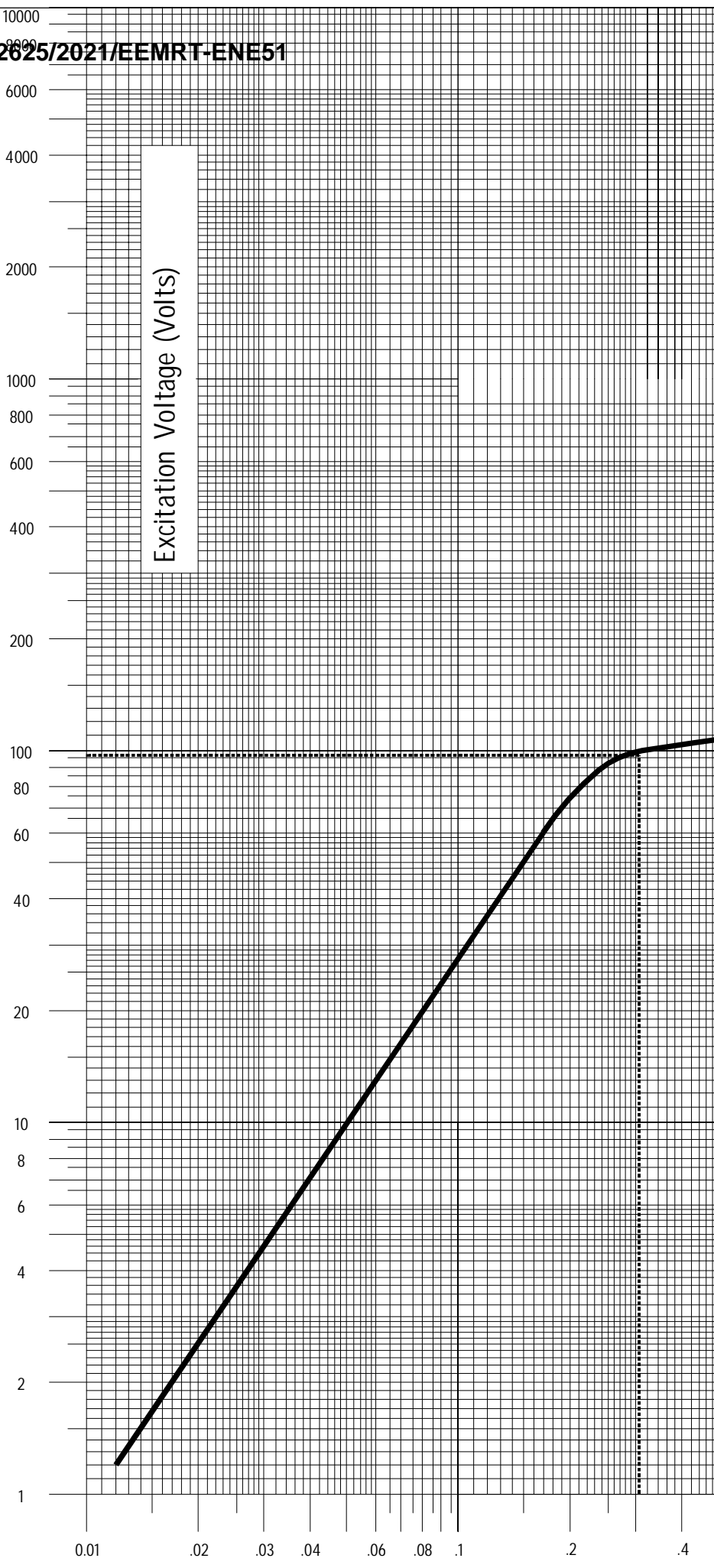

Notes:  
 1. The exciting current calculated from this graph does not take into account the current drawn by the protective device.  
 2. The values on the Voltage scale are to be multiplied by C1, while those on the current scale by C2.

Calculated Excitation Curve of Current Transformer

Type: **IMB145**

CORE 1      RATIO: 600-300/1, CLASS OF ACCURACY: 5P  
 20VA, 5P20

CORE 2      RATIO: 600-300/1, CLASS OF ACCURACY: PX  
 Vk >60(Rct+10) V, Rct < 6/3 Ohms, Io < 50/100mA at Vk

- (A) New drg. prepared.
- (B) Core-1 revised

NOTE : DRAWING APPROVAL SUBJECT TO VALID TYPE TEST REPORTS, TO BE CHECKED DURING ACCEPTANCE TESTS.

Chief Engineer/Construction

This document is COMPUTER ORIGINAL and does not need signature for its authentication

Drn: SR      Chkd: PDS      Apprd: SN



filename: 3320-010

1HYT903320-010

NOTE : DRAWING APPROVAL SUBJECT TO VALID TYPE TEST REPORTS, TO BE CHECKED DURING ACCEPTANCE TESTS.

**Annexure-A**  
**GUARANTEED TECHNICAL PARTICULARS FOR**  
**CURRENT TRANSFORMERS (145kV CT: 600-300/1-1-1 A)**

1	Type of tank/Installation Dead/Live Tank Type	Dead tank, Single phase, Oil Filled, Outdoor Type
2	Type of mounting	Pedestal Mounting
3	Manufacturer's Name and address and Country of Manufacture	APPSIL (Formerly - ABB India Ltd) Maneja, Vadodara – 390013 India
4	Whether Conforming to IEC 61869 standard	Yes
5 a) i)	Primary and Secondary winding made out of	Primary – Aluminum, Secondary – Copper
ii)	Primary windings -Design density for short circuit current -Conductivity of metal used -	Aluminum - 42.8 Amp/mm <sup>2</sup> (approx.) - As per IEC
b) i)	Area of cross section of primary winding	736 mm <sup>2</sup> (approx.)
ii)	Area of cross section of secondary winding	PX : 2.6 mm <sup>2</sup> (approx.) Metering : 0.82 mm <sup>2</sup> (approx.)
c)	Material used for providing secondary terminals	Brass (Primary Terminal will be Al)
d)	Material used for providing secondary terminals	Brass
e)	Whether Primary is Rigid Bar type in case of live tank	Not applicable
6	Rated primary voltage (kV rms)	132 KV / root3
7	Rated highest voltage (kV rms)	145 KV
8	Rated frequency (Hz)	50 Hz
9	Rated primary current (A)	600-300 A
10	Rated secondary current (A)	1
11	Ratio taps (on secondary side only)	On Secondary Side
12	Type of insulation	Class A
13	Seismic acceleration (g)	0.3 g vertical
14	RIV at 1.1 x Rated voltage (mv)	< 500 micro volts
15	Tank material and Tank coating	Mild Steel, HDG
16	Hardware exposed to atmosphere	HDG
17	Bolts, Nuts and Washers	MS Hot dip galvanized.
18	Porcelain housing and it make (Single piece only)	Hollow type, IEC/BHEL/ABIL/ADI/Modern or Equivalent Make
19	Sealing (Nitrogen gas cushion/Metal bellow)	Nitrogen cushion
20	Instrument security factor	<5 (For Metering core only)
21	Whether Tan Delta test tap provided	Yes
22	Whether secondary terminal plate is of molded epoxy resin type	Yes
23	Whether primary terminal bushings are of molded Epoxy cast resin/Glass fiber reinforced Polymer	Molded cast resin & Porcelain
24	Whether all seals are of "O" ring type	Yes "O" ring & Flat gasket
25	Whether all "O" Rings are fixed in machined	Yes

**Chief Engineer/Construction**

4252625/2021/EEMRT/ENES/

## REPORTS, TO BE CHECKED DURING ACCEPTANCE TESTS.

	grooves with adequate space for compression'				
26	Whether the main hollow insulator has the flanges cemented at both ends	Yes			
27	Whether "O" Rings are of Nitrile butyl rubber or Viton	Yes (NBR)			
28	Whether the Short circuit Ampere-turns of the CT being supplied is same as type tested CTs	Yes			
29	Tan Delta	Shall be less than 0.350%			
30	Whether ratio selection is achieved only in secondary	Yes			
31	Whether ratio selection is achieved only in secondary	Yes			
32	Whether Non return drain valve for oil sampling is arranged for 132kV and above CT/IVT	Bolt Type			
33	Acceptable limit of temperature	As per IS/IEC			
34	Partial Discharge Level	< 5 at $U_m \times 1.2/\sqrt{3}$ , < 10 at $U_m$ (where $U_m$ is highest system voltage)			
35	Rated short time withstand current for 1 sec. duration (kA rms)	31.5 kA			
36	Rated dynamic withstand current (kAp)	78.75 kA			
37	Rated continuous thermal current (pu) where pu = rated current	120% of rated primary current			
38	1.2/50 micro second impulse withstand voltage (kVp)	650			
39	One minute power frequency withstand voltage (kV rms) of primary winding (Dry)	275			
40	One minute power frequency withstand voltage of secondary winding (kV rms)	3			
41. a)	Minimum total creepage distance of insulator bushing (mm)	3625 mm (25mm/kV) Porcelain Insulator			
b)	Protected creepage of distance of bushing (mm)	Not Applicable			
42	Details of Cores	Core-I	Core-II	Core-III	
42.1	Current Ratios A/A	600-300 /1	600-300 /1	600-300 /1	
42.2	Output burden (VA)	20	-	20	
42.3	Class of accuracy	5P	PX	0.2S	
42.4	Accuracy limit factor / ISF	20	-	5	
42.5	Min. knee point voltage (kpv) in volts	-	>60 (Rct+10)	-	
42.6	Secondary resistance corrected to 75 deg.C in ohms	-	6-3 Ohms	-	
42.7	Max. Exciting current (mA) at - 20% of knee point voltage - 50% of knee point voltage - 100% of knee point voltage	- - -	- - 50-100	- - -	
42.8	Application	Prot.	PX	Metering	
43	Weight of oil (Kg.)	75 Kg (approx.)			

Drawing approval subject to valid vendor registra

**Chief Engineer/Construction**

**4252625/2021/EEMRT-ENE51**

44	Approximate weight of Copper used (Kgs)	22 Kg.
45	Approximate weight of Steel used (Kgs)	160 kg.
46	Total Weight (Kg.)	550 kG. (approx.)
47	Mounting details	400x500 (Please refer GA enclosed)
48	Overall dimensions	Please refer GA drawing enclosed
49	Characteristics (whether graphs enclosed):	
a)	Ratio and phase angle curves	Yes
b)	Magnetization curves	Yes
c)	Ratio correction factor curves	NA
50	Core	
a)	Area of cross section (sq.cm.)	44.6 sq. cm. (PX Core)
b)	Flux density at rated primary current and rated burden	As per Standard design practice
c)	Grade	M4 (Or equivalent) For PX Core Nano Core For Metering Core

**Chief Engineer/Construction**

**NOTE : DRAWING APPROVAL SUBJECT TO VALID TYPE TEST REPORTS, TO BE CHECKED DURING ACCEPTANCE TESTS.**

Drawing approval subject to valid vendor registration