

145 KV CURRENT TRANSFORMER TYPE: IMB 145

CLIENT:
(AS APPLICABLE)

Drawing approval subject to valid vendor registration

END CUSTOMER:
APTRANSCO

W.O. NO.:
(AS APPLICABLE)

PROJECT:
(AS APPLICABLE)

P.O. NO.:
(AS APPLICABLE)

QTY.:
(AS APPLICABLE)

CT RATIO:
800-500/1-1-1

SR. NO.	REFERENCE OF STD DRGS/ DOCUMENTS	REV.	DESCRIPTION
1.	1HYT903320-012	B	GENERAL ARRANGEMENT
2.	1HYT903320-013	B	RATING PLATE
3.	1HYT903320-014	B	SECONDARY TERMINAL BOX
4.	1HYT903320-015	A	MAGNETIZATION CURVE

Chief Engineer/Construction

NOTE : DRAWING APPROVAL SUBJECT TO VALID TYPE TEST REPORTS, TO BE CHECKED DURING ACCEPTANCE TESTS.

Prepared: SR	Checked: PDS	Approved: SN
Without Sep. PL.: <input type="checkbox"/>	SamePL.Same No.: <input type="checkbox"/>	Sep. PL.Other No.: <input type="checkbox"/>
Derived by:	Supersedes:	Supersedes by:
A 2021-01-11		
B 2021-01-21		

LIST OF DOCUMENTS FOR IMB 145 TYPE CT

1HYT903320-011

Scale NTS
T.Sh. 1
Sheets 1

We reserve all rights in this document and in the information contained there in Reproduction,use or disclosure to third parties without express authority is strictly forbidden ©ABB.

Ⓐ New drg. prepared.

Ⓑ Change in sr no. 1,2,3

This drawing is a COMPUTER ORIGINAL and does not require signature for its authentication



This drawing is a COMPUTER ORIGINAL and does not require signature for its authentication

Revision Details:
Ⓑ Twin terminal provided

Revision Details:
Ⓐ New drg. prepared.

We reserve all rights in this document and in the information contained therein. Reproduction, use or disclosure to third parties without express authority is strictly forbidden. © ABB

Drawing approval subject to valid vendor registration

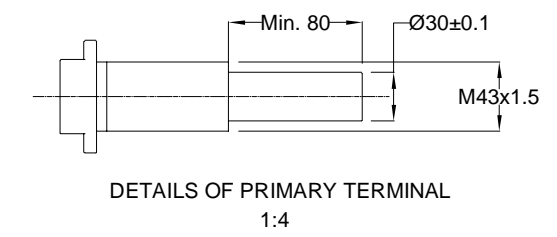
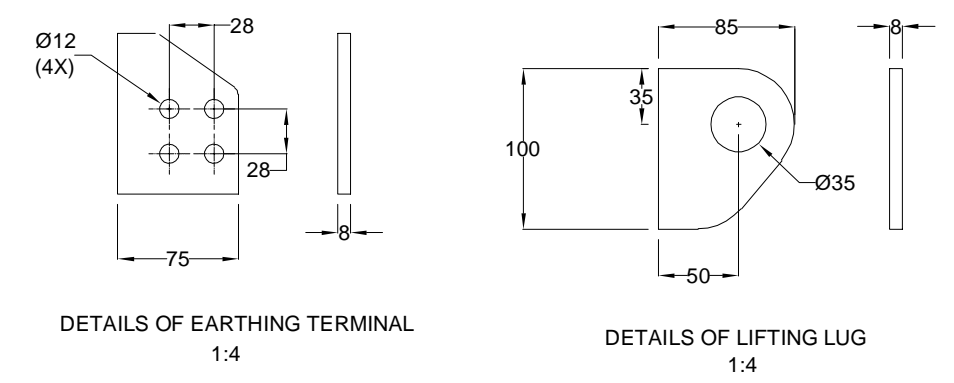
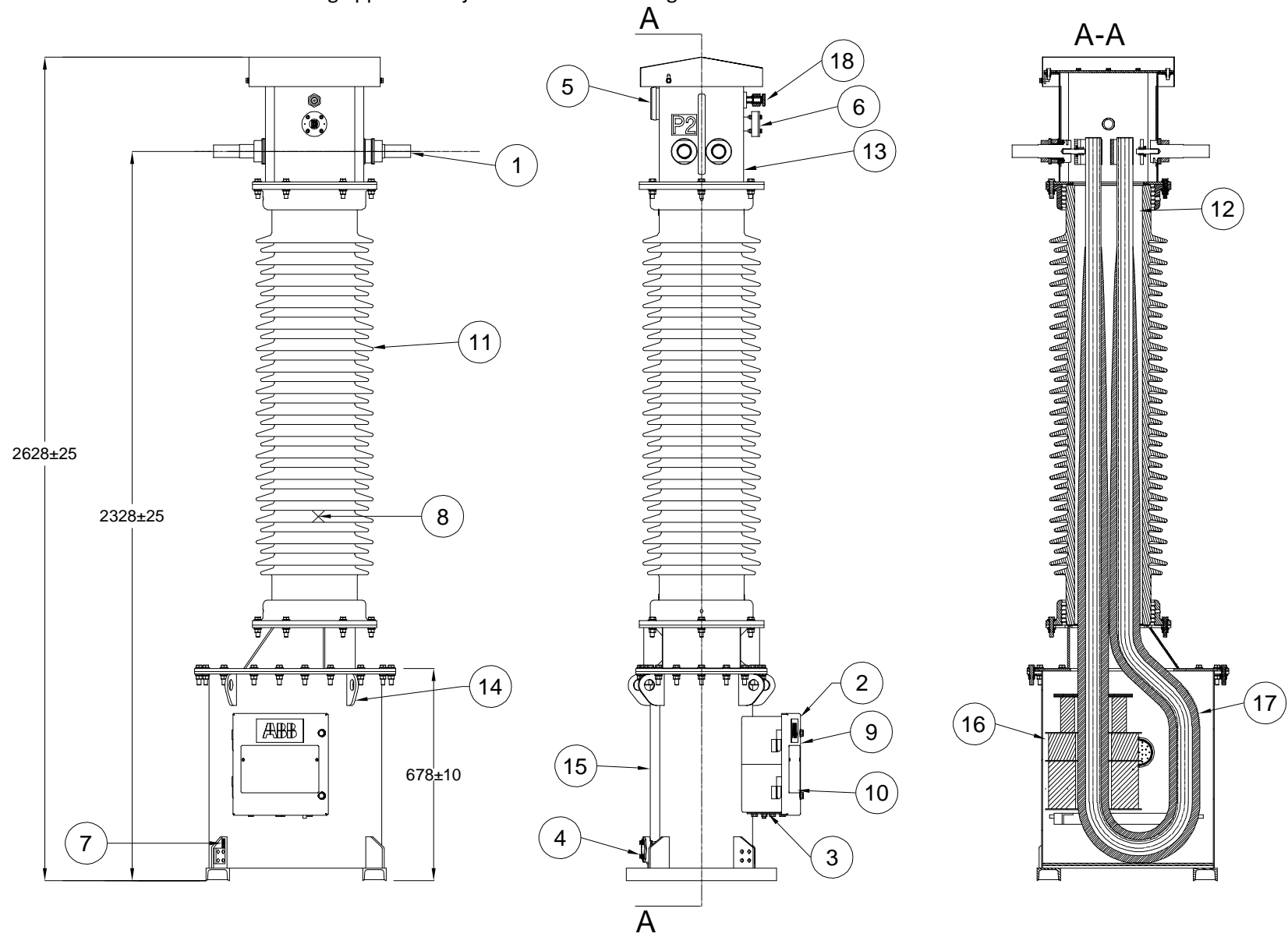

18	PRESSURE RELEASE DEVICE	1	S.S/BRASS
17	PRIMARY WINDING	1	PRIMARY CONDUCTOR (ALU.)
16	CORE STACK	1	-
15	BOTTOM TANK & TANK COVER	1	M.S HDG*
14	LIFTING LUG	4	M.S HDG*
13	TOP CHAMBER	1	M.S HDG*
12	TRANSFORMER OIL	~75 KG	EHV GRADE IEC 60296
11	INSULATOR	1	PORCELAIN
10	RATING PLATE	1	ALU.
9	D3 TERMINAL	1	INSIDE TERMINAL BOX
8	CENTRE OF GRAVITY	-	-
7	EARTH CLAMP	2	S.S WELDED OVER M.S
6	OIL LEVEL INDICATOR	1	TOUGHENED GLASS
5	OIL & NITROGEN FILLING PLUG	1	M.S HDG*
4	OIL DRAIN PLUG WITH BLANKING PLATE	1	M.S HDG*
3	REMOVABLE GLAND PLATE	1	M.S HDG*
2	SECONDARY TERMINAL BOX	1	M.S HDG*
1	PRIMARY TERMINAL	4	ALU.
Sr No.	Item Description	Qty.	Material

*HOT DIP GALVANIZED ON OUTER SURFACE AND PAINTED ON INNER SURFACE
INNER SURFACE PAINTED WITH OIL RESISTIVE PAINT

TOTAL WEIGHT 550 kg. APPROX
CREEPAGE DISTANCE 3625 mm
ALL FERROUS PARTS EXPOSED TO
ATMOSPHERE ARE HDG.

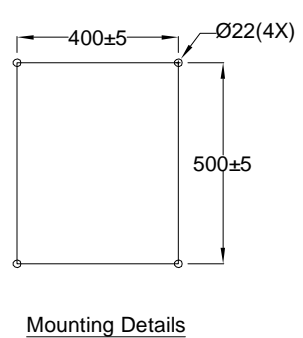

GENERAL TOLERANCE AS PER ISO:2768-C.

NOTE : DRAWING APPROVAL SUBJECT TO VALID TYPE TEST REPORTS, TO BE CHECKED DURING ACCEPTANCE TESTS.

Chief Engineer/Construction

Revision		OUTDOOR 145 kV CURRENT TRANSFORMER TYPE IMB 145	GENERAL ARRANGEMENT DRAWING (For CT with Small Tank)	Prepared: SR	Checked: PDS	Approved: SN	file: 3320-012	Total sh. 1
A	2021-01-11			ABB APPSIL			1HYT903320-012	Sh.No. 1
B	2021-01-21							

Drawing approval subject to valid vendor registration

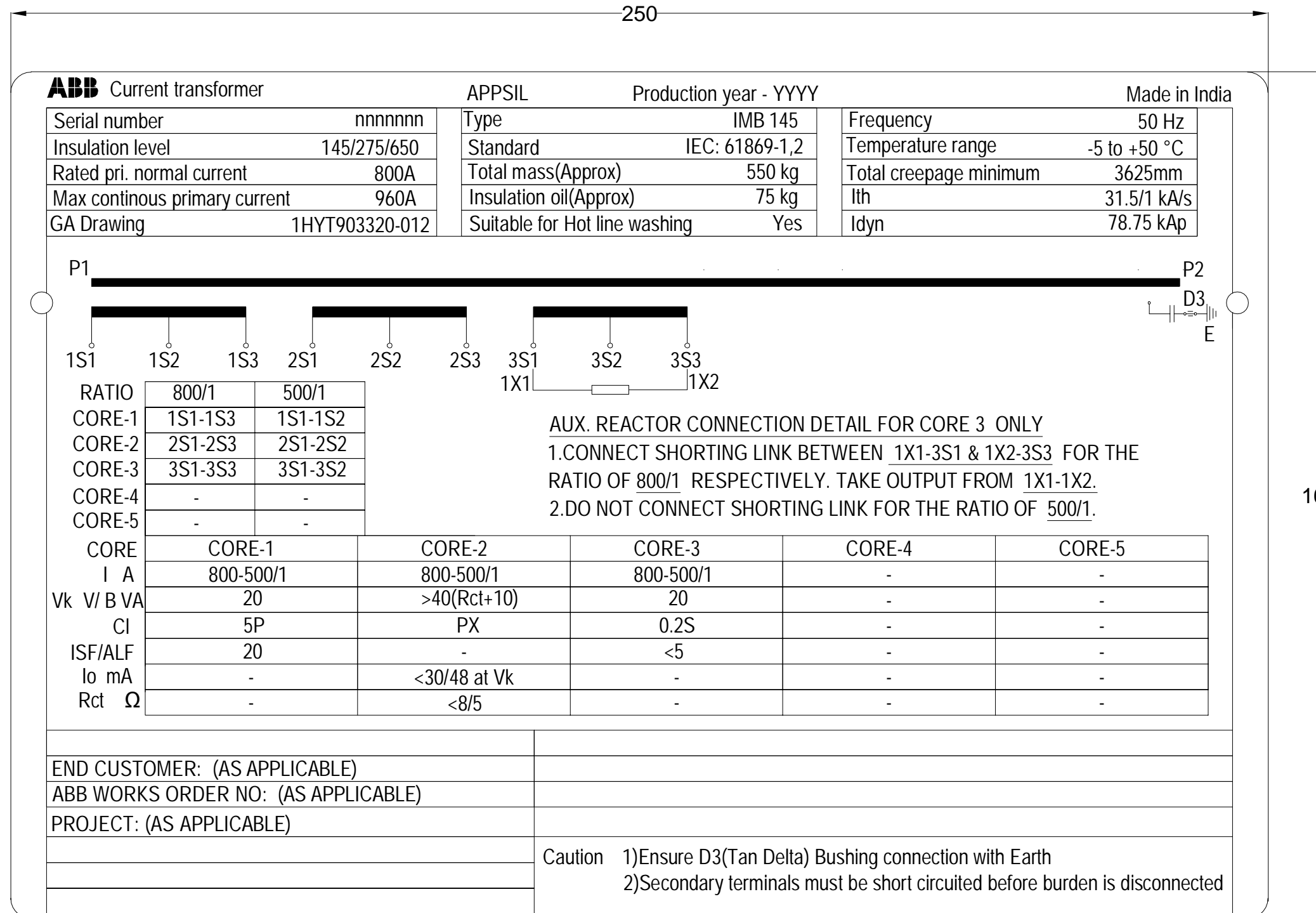

Serial number nnnnnnn to be decided when manufactured
 Production year yyyy = Actual year,date & month of Production
 Material: Aluminium 2mm Thk.
 Letter height 3 mm

NOTE : DRAWING APPROVAL SUBJECT TO VALID TYPE TEST REPORTS, TO BE CHECKED DURING ACCEPTANCE TESTS.

Chief Engineer/Construction

This drawing is a COMPUTER ORIGINAL and does not require signatures for its authentication

Revision Details:
 (B) Reactor added at 800/1 tap

Revision Details:
 (A) New drg prepared.

We reserve all rights in this document and in the information contained there in. Reproduction, use or disclosure to third parties without express authority is strictly forbidden. © ABB.

Revision		145 kV OUTDOOR CURRENT TRANSFORMER TYPE IMB 145	RATING PLATE 2GHV080292P0004	Prepared: SR	Checked: PDS	Approved: SN	File: 3320-013	Total sh. 1
A	2021-01-11			ABB APPSIL			1HYT903320-013	Sh.No. 1
B	2021-01-21							

Drawing approval subject to valid vendor registration

This document is COMPUTER ORIGINAL and does not need signature for its authentication

B

C

D

E

F

A

B

C

D

E

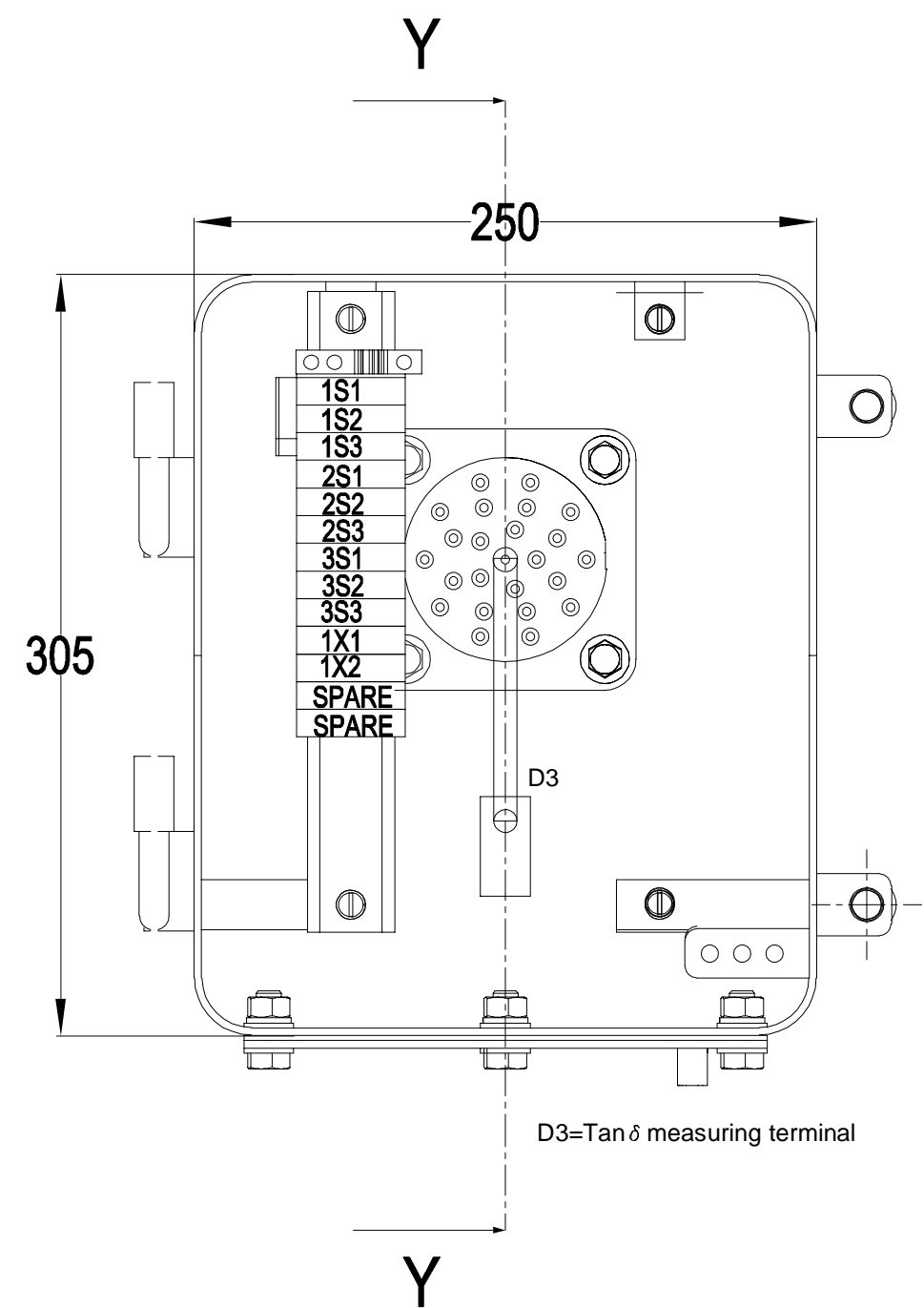
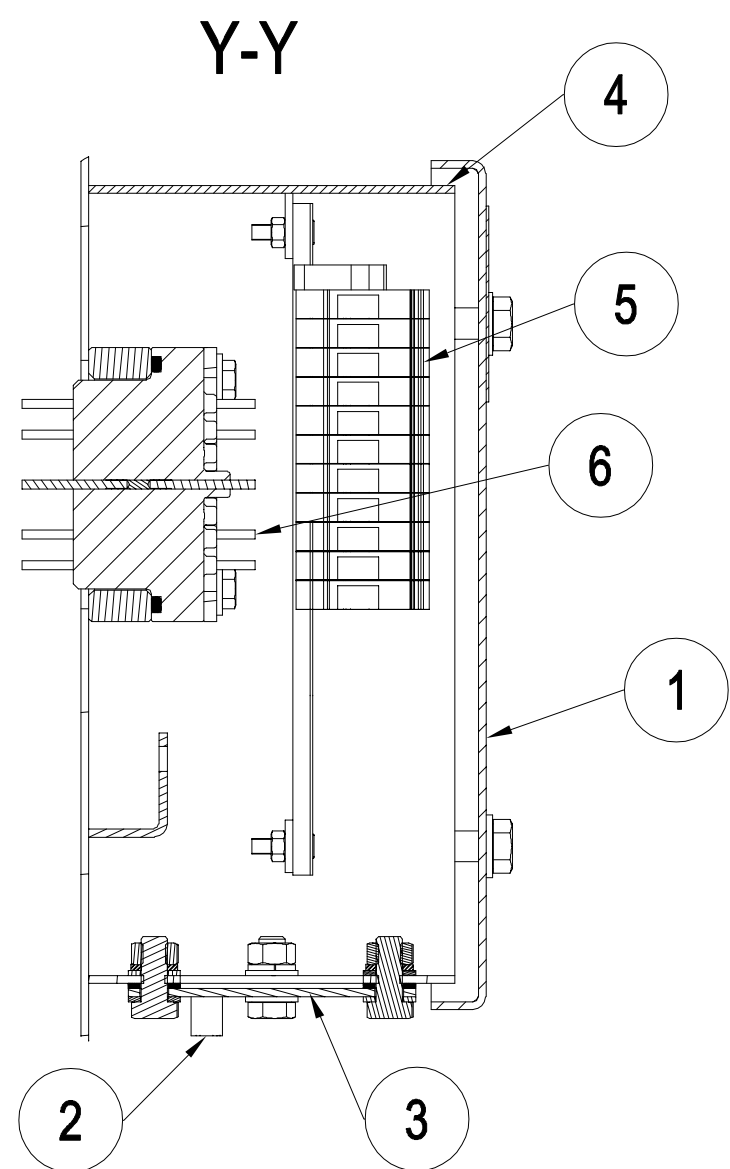

FOR CORE 3 ONLY

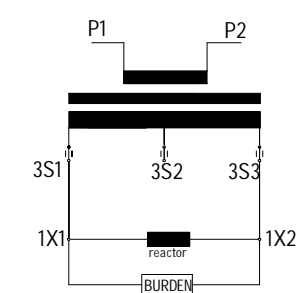

FOR RATIO OF 800/1

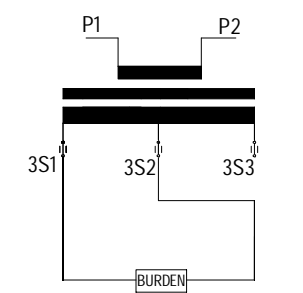

FOR RATIO OF 500/1

Revision Details:
B Reactor added for 800/1 tap. Gland plate thickness added

Revision Details:
A New Drawing prepared

We reserve all rights in this document and in the information contained there in. Reproduction, use or disclosure to third parties without express authority is strictly forbidden ©ABB.

NOTES :-
 1) DEGREE OF PROTECTION IP 55
 2) THE SECONDARY TERMINAL BOX IS HDG
 3) D3 TERMINAL IS FOR THE MEASUREMENT OF POWER FACTOR AND LOSS ANGLE
 4) THE BOX IS SUITABLE FOR ACCOMMODATING SECONDARY CABLES OF 1100 V
 5) STEEL SHEET 3.15 mm THICK HOT ROLLED
 6) ALL DIMENSIONS ARE IN mm. GENERAL TOLERANCE AS PER ISO: 2768-c
 7) NO. OF WIRES SHOWN IN THE TERMINAL BLOCK ARE INDICATIVE ONLY

Chief Engineer/Construction

NOTE : DRAWING APPROVAL SUBJECT TO VALID TYPE TEST REPORTS, TO BE CHECKED DURING ACCEPTANCE TESTS.

6	COPPER WIRE
5	SERIES TERMINAL STUD TYPE
4	EPDM GASKET
3	UNDRILLED GLAND PLATE (3mm Thk.)
2	DRAIN TUBE
1	COVER
SR NO	ITEM DESCRIPTION

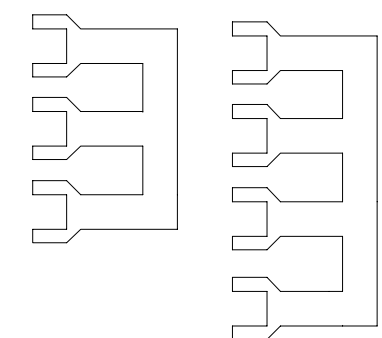

S-Shorting link

Revision		CURRENT TRANSFORMER TYPE : IMB 145 SEC. TERMINAL BOX : DETAILS	DRAWN: SR	CHECKED: PDS	APPRD: SN	file: 3320-014	TOTAL SH. 1
A	2021-01-11		ABB APPSIL		1HYT903320-014		Sh. NO. 1
B	2021-01-21						

4252827/2021/EEMRT-ENE51

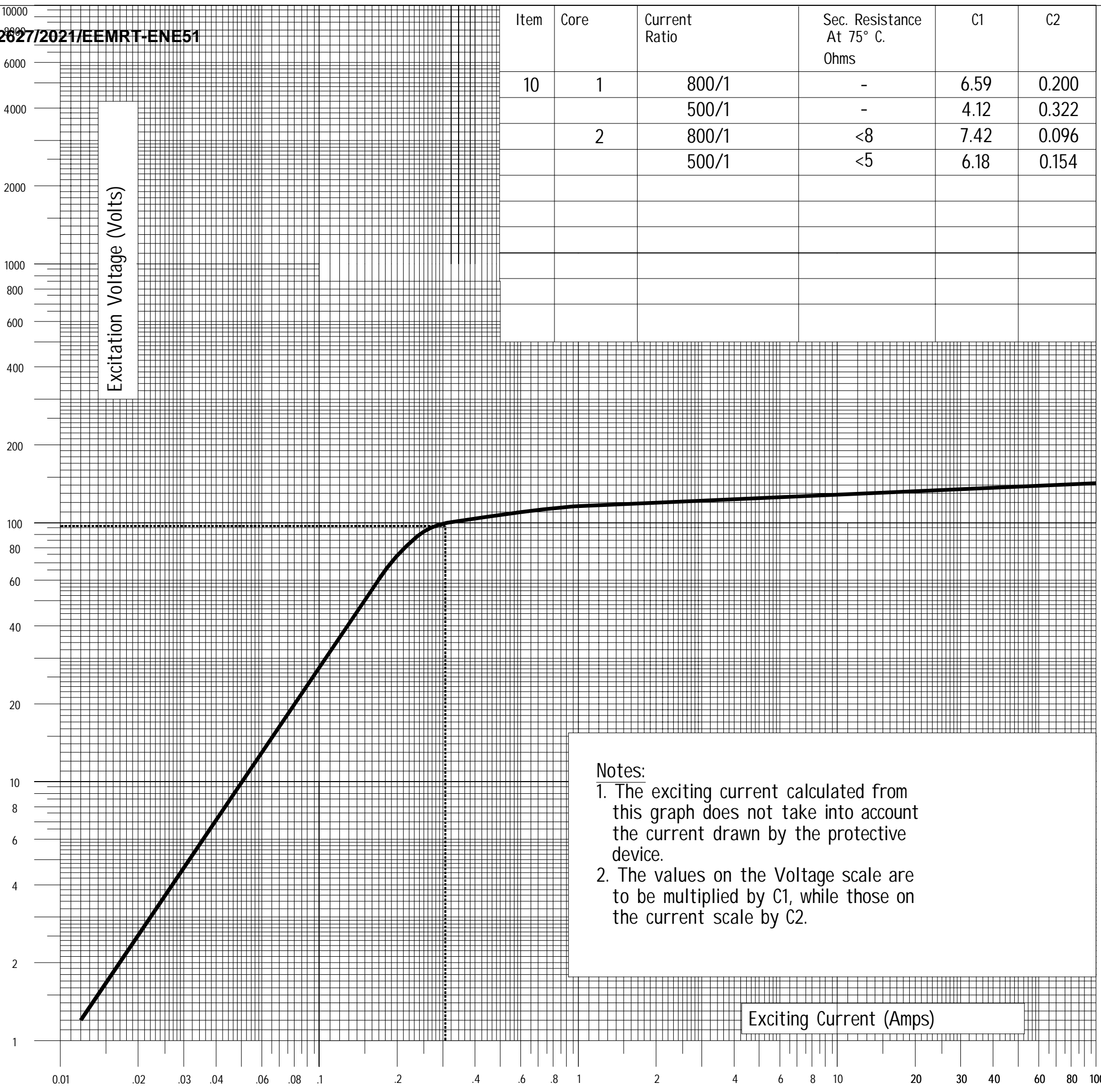

Notes:

1. The exciting current calculated from this graph does not take into account the current drawn by the protective device.
2. The values on the Voltage scale are to be multiplied by C1, while those on the current scale by C2.

Calculated Excitation Curve of Current Transformer

Type: **IMB145**

CORE 1 RATIO: 800-500/1, CLASS OF ACCURACY: 5P
20VA, 5P20

CORE 2 RATIO: 800-500/1, CLASS OF ACCURACY: PX
Vk >40(Rct+10) V, Rct <8/5 Ohms, Io <30/48mA at Vk

(A) New drg.
prepared.

NOTE : DRAWING APPROVAL SUBJECT TO VALID TYPE TEST REPORTS, TO BE CHECKED DURING ACCEPTANCE TESTS.

Chief Engineer/Construction

This document is COMPUTER ORIGINAL and does not need signature for its authentication

Drn: SR Chkd: PDS Apprd: SN



filename: 3320-015

1HYT903320-015

Annexure-A**GUARANTEED TECHNICAL PARTICULARS FOR
CURRENT TRANSFORMERS (145kV CT: 800-500/1-1-1 A)**

1	Type of tank/Installation Dead/Live Tank Type	Dead tank, Single phase, Oil Filled, Outdoor Type
2	Type of mounting	Pedestal Mounting
3	Manufacturer's Name and address and Country of Manufacture	APPSIL (Formerly - ABB India Ltd) Maneja, Vadodara – 390013 India
4	Whether Conforming to IEC 61869 standard	Yes
5 a) i)	Primary and Secondary winding made out of	Primary – Aluminum, Secondary – Copper
ii)	Primary windings -Design density for short circuit current -Conductivity of metal used -	Aluminum - 21.39 Amp/mm ² (approx.) - As per IEC
b)	i) Area of cross section of primary winding	1472 mm ² (approx.)
	ii) Area of cross section of secondary winding	PX : 1.59 mm ² (approx.) Metering : 0.82 mm ² (approx.)
c)	Material used for providing secondary terminals	Brass (Primary Terminal will be Al)
d)	Material used for providing secondary terminals	Brass
e)	Whether Primary is Rigid Bar type in case of live tank	Not applicable
6	Rated primary voltage (kV rms)	132 KV / root3
7	Rated highest voltage (kV rms)	145 KV
8	Rated frequency (Hz)	50 Hz
9	Rated primary current (A)	800-500 A
10	Rated secondary current (A)	1
11	Ratio taps (on secondary side only)	On Secondary Side
12	Type of insulation	Class A
13	Seismic acceleration (g)	0.3 g vertical
14	RIV at 1.1 x Rated voltage (mv)	< 500 micro volts
15	Tank material and Tank coating	Mild Steel, HDG
16	Hardware exposed to atmosphere	HDG
17	Bolts, Nuts and Washers	MS Hot dip galvanized.
18	Porcelain housing and it make (Single piece only)	Hollow type, IEC/BHEL/ABIL/ADI/Modern or Equivalent Make
19	Sealing (Nitrogen gas cushion/Metal bellow)	Nitrogen cushion
20	Instrument security factor	<5 (For Metering core only)
21	Whether Tan Delta test tap provided	Yes
22	Whether secondary terminal plate is of molded epoxy resin type	Yes
23	Whether primary terminal bushings are of molded Epoxy cast resin/Glass fiber reinforced Polymer	Molded cast resin & Porcelain
24	Whether all seals are of "O" ring type	Yes "O" ring & Flat gasket
25	Whether all "O" Rings are fixed in machined grooves with adequate space for compression'	Yes

Chief Engineer/Construction

4252627/2021/EEMRT-ENE51

REPORTS, TO BE CHECKED DURING ACCEPTANCE TESTS.

26	Whether the main hollow insulator has the flanges cemented at both ends	Yes				
27	Whether "O" Rings are of Nitrile butyl rubber or Viton	Yes (NBR)				
28	Whether the Short circuit Ampere-turns of the CT being supplied is same as type tested CTs	Yes				
29	Tan Delta	Shall be less than 0.350%				
30	Whether ratio selection is achieved only in secondary	Yes				
31	Whether ratio selection is achieved only in secondary	Yes				
32	Whether Non return drain valve for oil sampling is arranged for 132kV and above CT/IVT	Bolt Type				
33	Acceptable limit of temperature	As per IS/IEC				
34	Partial Discharge Level	< 5 at $U_m \times 1.2/\sqrt{3}$, < 10 at U_m (where U_m is highest system voltage)				
35	Rated short time withstand current for 1 sec. duration (kA rms)	31.5 kA				
36	Rated dynamic withstand current (kAp)	78.75 kA				
37	Rated continuous thermal current (pu) where pu = rated current	120% of rated primary current				
38	1.2/50 micro second impulse withstand voltage (kVp)	650				
39	One minute power frequency withstand voltage (kV rms) of primary winding (Dry)	275				
40	One minute power frequency withstand voltage of secondary winding (kV rms)	3				
41. a)	Minimum total creepage distance of insulator bushing (mm)	3625 mm (25mm/kV) Porcelain Insulator				
b)	Protected creepage of distance of bushing (mm)	Not Applicable				
42	Details of Cores	Core-I	Core-II	Core-III		
42.1	Current Ratios A/A	800-500 /1	800-500 /1	800-500 /1		
42.2	Output burden (VA)	20	-	20		
42.3	Class of accuracy	5P	PX	0.2S		
42.4	Accuracy limit factor / ISF	20	-	5		
42.5	Min. knee point voltage (kpv) in volts	-	>40 (Rct+10)	-		
42.6	Secondary resistance corrected to 75 deg.C in ohms	-	8-5 Ohms	-		
42.7	Max. Exciting current (mA) at - 20% of knee point voltage - 50% of knee point voltage - 100% of knee point voltage	- - -	- - 30-48	- - -		
42.8	Application	Prot.	PX	Metering		
43	Weight of oil (Kg.)	75 Kg (approx.)				
44	Approximate weight of Copper used (Kgs)	7.0 Kg.				
45	Approximate weight of Steel used (Kgs)	160 kg.				

Chief Engineer/Construction

4252627/2021/EEMRT-ENE51

46	Total Weight (Kg.)	550 kG. (approx.)
47	Mounting details	400x500 (Please refer GA enclosed)
48	Overall dimensions	Please refer GA drawing enclosed
49	Characteristics (whether graphs enclosed):	
a)	Ratio and phase angle curves	Yes
b)	Magnetization curves	Yes
c)	Ratio correction factor curves	NA
50	Core	
a)	Area of cross section (sq.cm.)	33.75 sq. cm. (PX Core)
b)	Flux density at rated primary current and rated burden	As per Standard design practice
c)	Grade	M4 (Or equivalent) For PX Core Nano Core For Metering Core

Chief Engineer/Construction

NOTE : DRAWING APPROVAL SUBJECT TO VALID TYPE TEST REPORTS, TO BE CHECKED DURING ACCEPTANCE TESTS.

Drawing approval subject to valid vendor registration