

NOTE : DRAWING APPROVAL SUBJECT TO VALID TYPE TEST REPORTS, TO BE CHECKED DURING ACCEPTANCE TESTS.



FOR EPC CONTRACTS ONLY

SCHEDULE-II

SCHEDULE OF GUARANTEED TECHNICAL PARTICULARS FOR 120kV 10kA TYPE-SM METAL OXIDE GAPLESS PORCELAIN LIGHTNING ARRESTER

1. Name of Manufacturer : LAMCO INDUSTRIES PRIVATE LIMITED.
H.O & WORKS: SANATHNAGAR-IE, HYD
WORKS: AUTOMOTIVE PARK, TSIIC,
MUPPIREDDYPALLY, T.S, INDIA.
2. Type/ : Station Class Metal Oxide Gapless Lightning Arresters, "MORESTER" type-SM, MODEL-'LMAS'
Model (Drawing No.) : 2211215
3. Applicable standards : IEC 60099-4 of 2014
4. No.of Units & rating of each unit : 2 (60KV)
5. Rated Arrester voltage KVRms : 120 **Drawing approval subject to valid vendor registration**
6. Rated Frequency Hz : 50
7. Max. continuous operating voltage KVRms : 106
8. Temporary PF overvoltage capacity (kVpeak) (with prior duty)
 - a) for 0.1 second KVP : 220
 - b) for 1 second KVP : 212
 - c) for 10 second KVP : 203
 - d) for 100 second KVP : 190
9. Nominal discharge current (8/20us) KA: 10
10. Long duration Energy discharge class : STATION MEDIUM
11. Min. energy discharge capability "(KJ/KV) of Ur" : 7
(for 3 Sequential shots)
12. Seismic acceleration vertical & horizontal : 0.3g
13. Maximum switching current impulse : 280 KVP
residual voltage at 1000A
14. Maximum residual voltage at nominal discharge current of 8/20 us wave
 - a) 5 KA KVpeak : 290
 - b) 10 KA KVpeak : 300
 - c) 20 KA KVpeak : 340
15. Min. prospective symmetrical current kA : 40

Chief Engineer
Projects

16. Max. steep front residual voltage at
10KA with one micro sec. rise time : 333 KV_{peak}
17. Repetitive charge transfer rating Qrs : 1.6C
18. High current short duration (KAp) impulse
withstand level with 4/10 us wave KAP : 100
19. Pressure relief class : A (40 KA)
20. a) Reference voltage Kv : Greater than the rated arrester
voltage at 3mA reference current
b) Reference current mA : 3
c) Leakage current at COV mA : Less than 0.8
21. Minimum Total Creepage distance mm : 4495
22. Insulation withstand voltage of
arrester housing
i) Lightning Impulse withstand
voltage with 1.2/50us wave KV_{peak} : 650
ii) Switching impulse KV_{peak} : Not Applicable
iii) One minute PF withstand Voltage
of housing (Dry & wet) KV_{rms} : 275
23. Weight of complete unit Kgs : 115±10%
24. Overall Height of complete unit
from base to line side mm : 1860 ±72
25. Minimum recommended spacing between
center to center of LA mm : 2000
26. Min.distance between grounded object mm : 1700
27. Clearance required from ground equipment
at various heights of arrester units mm : 1700
28. Earthing arrangement provided for : provided (Ref Drg No:6220154).
earthing side of arrester.
29. Cantilever strength Kg : 500 (deflection 20mm)
30. R.I.V @ 1.1 COV : Less than 2500µV
31. Partial discharge @ 1.05 COV : Less than 10pC

**NOTE : DRAWING APPROVAL SUBJECT TO VALID TYPE TEST REPORTS, TO BE
CHECKED DURING ACCEPTANCE TESTS.**

Chief Engineer
Projects

Drawing approval subject to valid vendor registration

32. Details of metal oxide block :

a) Reference voltage	: 4.5
b) Material	: Zno
c) Diameter	: 64 ±2 mm
d) Height	: 34 ±2 mm

for **LAMCO INDUSTRIES PRIVATE LIMITED.**



(K. ARUN)

SENIOR MANAGER (D&D)

NOTE : DRAWING APPROVAL SUBJECT TO VALID TYPE TEST REPORTS, TO BE CHECKED DURING ACCEPTANCE TESTS.

- 1) Minimum 300mm plinth shall be maintained for CT/PT/CVT/Isolators in the substation during foundation works to ensure safe live to ground clearances as per IE rules.
- 2) Since the supply of terminal connectors is not in the scope of manufacturer as mentioned in the drawings, the EPC contractors shall be instructed to supply the same in line with CT/PT/CVT/Isolators requirement and compatibility.

Chief Engineer
Projects

DRAWING No.: DRAWINGNO.

NOTE : DRAWING APPROVAL SUBJECT TO VALID TYPE TEST REPORTS, TO BE CHECKED DURING ACCEPTANCE TESTS.

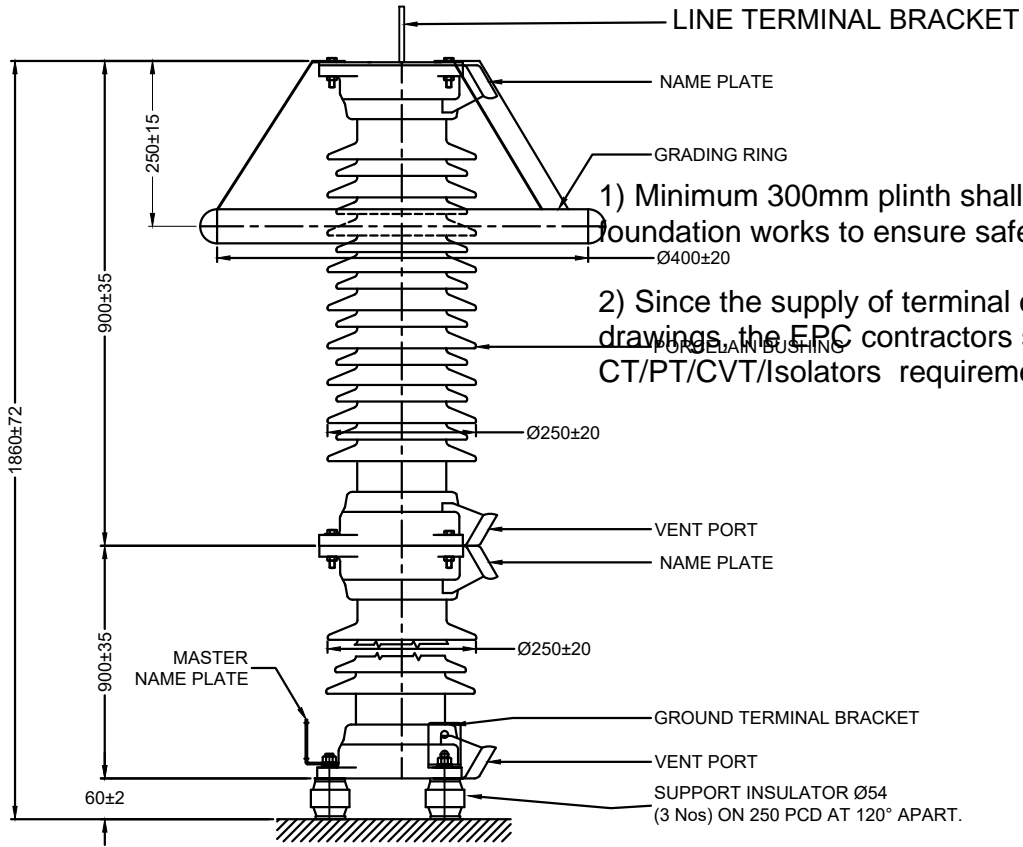

- 1) Minimum 300mm plinth shall be maintained for CT/PT/CVT/Isolators in the substation during foundation works to ensure safe live to ground clearances as per IE rules.
- 2) Since the supply of terminal connectors is not in the scope of manufacturer as mentioned in the drawings, the EPC contractors shall be instructed to supply the same in line with CT/PT/CVT/Isolators requirement and compatibility.

Chief Engineer
Projects

This drawing and design is the property of MEIL and must not be copied or lent without prior permission in writing

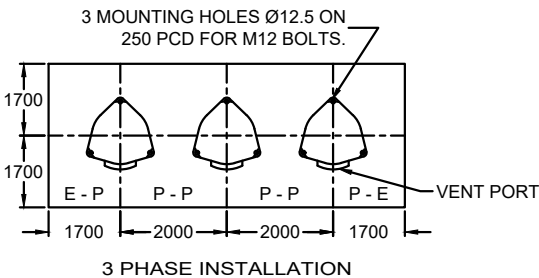

- NOTE :
1. FOR SURGE MONITOR REFER Drg. No. : 4249001A.
 2. FOR INSTALLATION AND INTERCONNECTION REFER Drg. No. : 4320010.
 3. TOTAL CREEPAGE DISTANCE 4495 mm (NOM).
 4. ARRESTER VENT PORTS SHOULD BE DIRECTED TOWARDS SAFE DIRECTION.
 5. WEIGHT OF THE ARRESTER 115±10%Kgs.

00	FIRST SUBMISSION	24.05.2023	K.B	K.A	K.A	K.A
REV.No.	DESCRIPTION	DATE	DRAWN	CHECKED	APPD.	STATUS
OWNER:		TRANSMISSION CORPORATION OF ANDHRA PRADESH LIMITED				
CONTRACTOR:		meil AS APPLICABLE				
PROJECT:		AS APPLICABLE				
L.O.I No.:		AS APPLICABLE				
TITLE:		120KV, 10KA LIGHTNING ARRESTER (MORESTER TYPE LMAS)				
DRAWING No.		SIZE	SCALE	TOTAL SHEETS	SH.No.	REV.
MEIL-APT-1239-GDV-S-2211215		A2	NTS	01	01of01	00

7537595/2023/EEMRT-ENE51

This drawing and design is the property of MEIL and must not be copied or lent without prior permission in writing

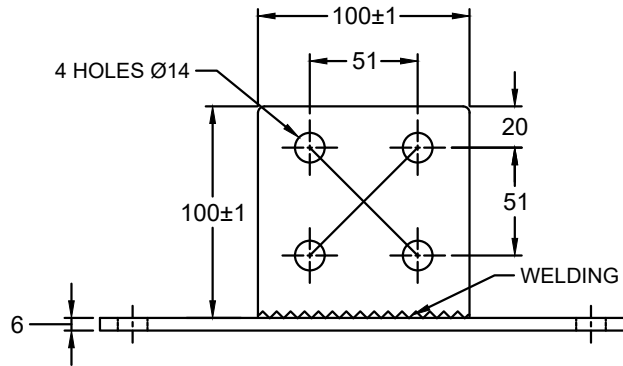
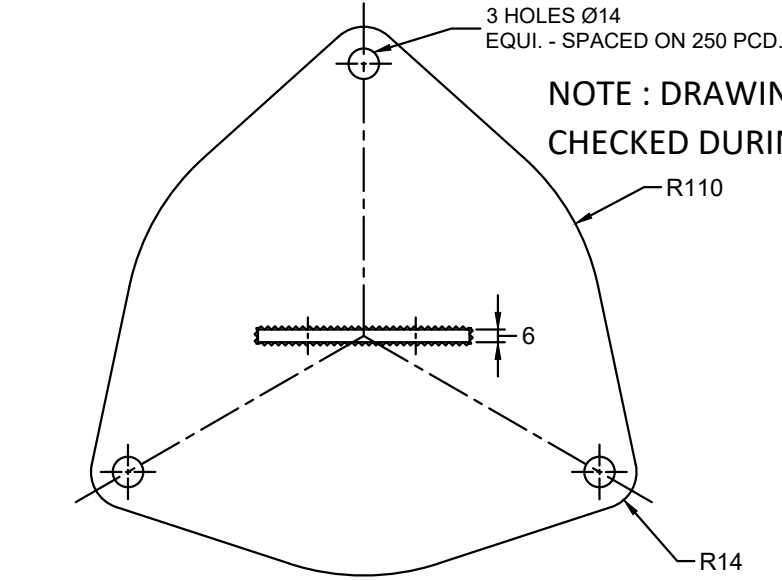

- NOTES :
1. MATERIAL : 6mm THICK M.S. SHEET.
 2. FINISH : HOT DIP GALVANISED.
 3. ALL HOLES Ø14 SIZE, UNLESS OTHER WISE SPECIFIED.
 4. WEIGHT : 1.7 Kgs ±10%

Chief Engineer
Projects

01	FIRST SUBMISSION	12.06.2023	K.B	K.A	K.A	K.A	
REV.No.	DESCRIPTION	DATE	DRAWN	ELE. CHECKED	CIVIL	APPD.	STATUS
OWNER: TRANSMISSION CORPORATION OF ANDHRA PRADESH LIMITED							
CONTRACTOR: AS APPLICABLE							
PROJECT: AS APPLICABLE							
L.O.I No.: AS APPLICABLE							
TITLE: LINE TERMINAL BRACKET							
DRAWING No.		SIZE	SCALE	TOTAL SHEETS	SH.No.	REV.	
MEIL-APT-1239-GDV-S-6220150D		A2	NTS	01	01of01	01	

DRAWING No.: DRAWINGNO.

NOTE : DRAWING APPROVAL SUBJECT TO VALID TYPE TEST REPORTS, TO BE CHECKED DURING ACCEPTANCE TESTS.

This drawing and design is the property of MEIL and must not be copied or lent without prior permission in writing

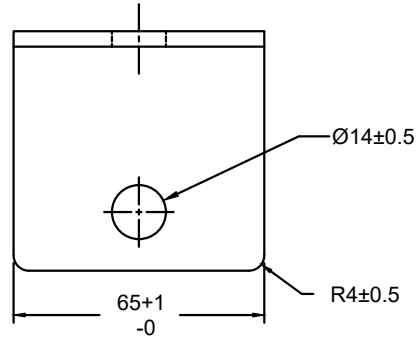

Chief Engineer
Projects

Drawing approval subject to valid vendor registration

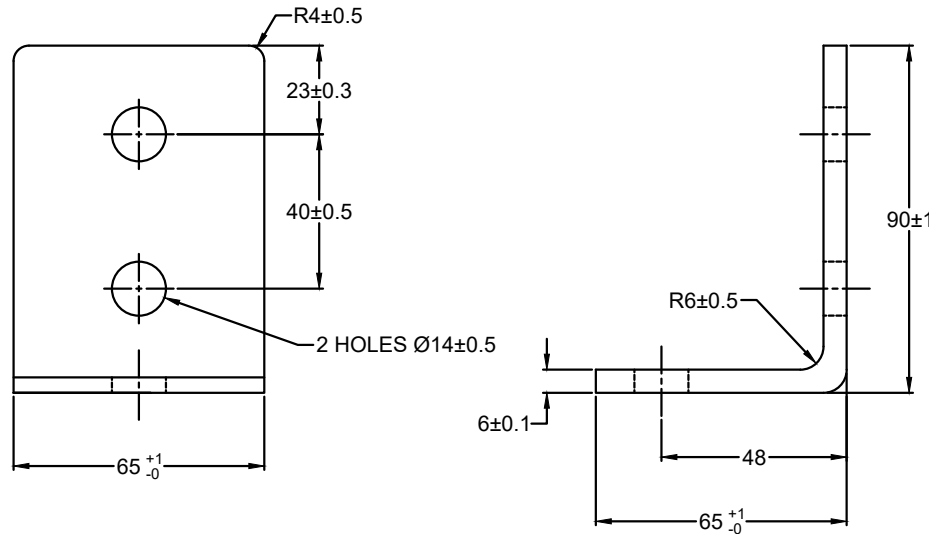

NOTE :

1. MATERIAL : M.S.PLATE.
2. FINISH : HOT DIP GALVANISED.
3. WEIGHT : 400 gms.±10%

REV.No.	DESCRIPTION	DATE	DRAWN	CHECKED	APPD.	STATUS
00	FIRST SUBMISSION	24.05.2023	K.B	K.A	K.A	K.A
				ELE	CIVIL	
OWNER:	TRANSMISSION CORPORATION OF ANDHRA PRADESH LIMITED					
CONTRACTOR:	meil AS APPLICABLE					
PROJECT:	AS APPLICABLE					
L.O.I No.:	AS APPLICABLE					
TITLE:	GROUND TERMINAL BRACKET					
DRAWING No.		SIZE	SCALE	TOTAL SHEETS	SH.No.	REV.
MEIL-APT-1239-GDV-S-6220154		A2	NTS	01	01of01	00

This drawing and design is the property of MEIL and must not be copied or lent without prior permission in writing

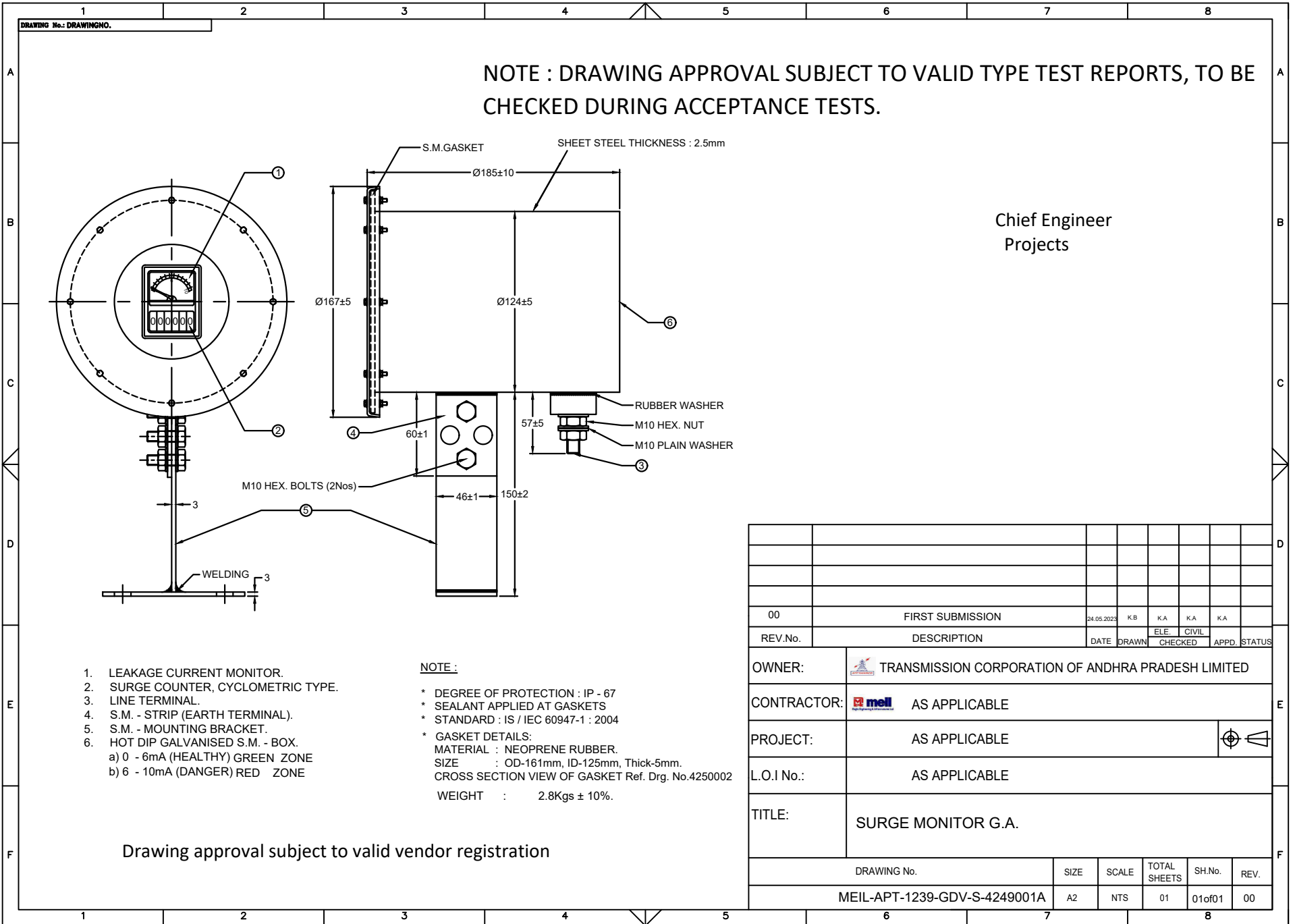

1. LEAKAGE CURRENT MONITOR.
2. SURGE COUNTER, CYCLOMETRIC TYPE.
3. LINE TERMINAL.
4. S.M. - STRIP (EARTH TERMINAL).
5. S.M. - MOUNTING BRACKET.
6. HOT DIP GALVANISED S.M. - BOX.
 - a) 0 - 6mA (HEALTHY) GREEN ZONE
 - b) 6 - 10mA (DANGER) RED ZONE

NOTE :

- * DEGREE OF PROTECTION : IP - 67
- * SEALANT APPLIED AT GASKETS
- * STANDARD : IS / IEC 60947-1 : 2004
- * GASKET DETAILS:
 MATERIAL : NEOPRENE RUBBER.
 SIZE : OD-161mm, ID-125mm, Thick-5mm.
 CROSS SECTION VIEW OF GASKET Ref. Drg. No.4250002
 WEIGHT : 2.8Kgs ± 10%.

Drawing approval subject to valid vendor registration

00	FIRST SUBMISSION	24.05.2023	K.B	K.A	K.A
REV.No.	DESCRIPTION	DATE	DRAWN	CHECKED	APPD. STATUS
OWNER:	TRANSMISSION CORPORATION OF ANDHRA PRADESH LIMITED				
CONTRACTOR:	meil AS APPLICABLE				
PROJECT:	AS APPLICABLE				⊕
L.O.I No.:	AS APPLICABLE				
TITLE:	SURGE MONITOR G.A.				
DRAWING No.		SIZE	SCALE	TOTAL SHEETS	SH.No. REV.
MEIL-APT-1239-GDV-S-4249001A		A2	NTS	01	01of01 00

This drawing and design is the property of MEIL and must not be copied or lent without prior permission in writing

DRAWING No.: DRAWINGNO.

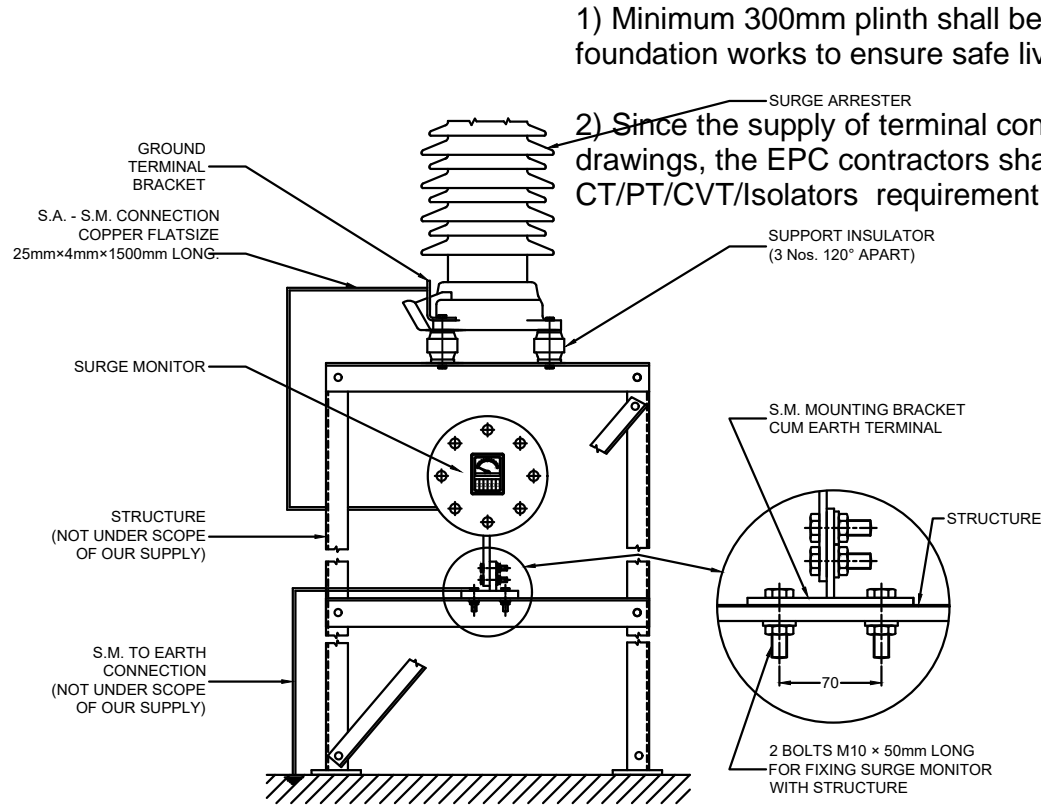

Drawing approval subject to valid vendor registration

NOTE : DRAWING APPROVAL SUBJECT TO VALID TYPE TEST REPORTS, TO BE CHECKED DURING ACCEPTANCE TESTS.

Chief Engineer
Projects

00	FIRST SUBMISSION	24.05.2023	K.B	K.A	K.A	K.A
REV.No.	DESCRIPTION	DATE	DRAWN	CHECKED	APPD.	STATUS
OWNER:	TRANSMISSION CORPORATION OF ANDHRA PRADESH LIMITED					
CONTRACTOR:	meil AS APPLICABLE					
PROJECT:	AS APPLICABLE					
L.O.I No.:	AS APPLICABLE					
TITLE:	METHOD OF CONNECTING SURGE MONITOR WITH SURGE ARRESTER					
DRAWING No.		SIZE	SCALE	TOTAL SHEETS	SH.No.	REV.
MEIL-APT-1239-GDV-S-4320026		A2	NTS	01	01of01	00

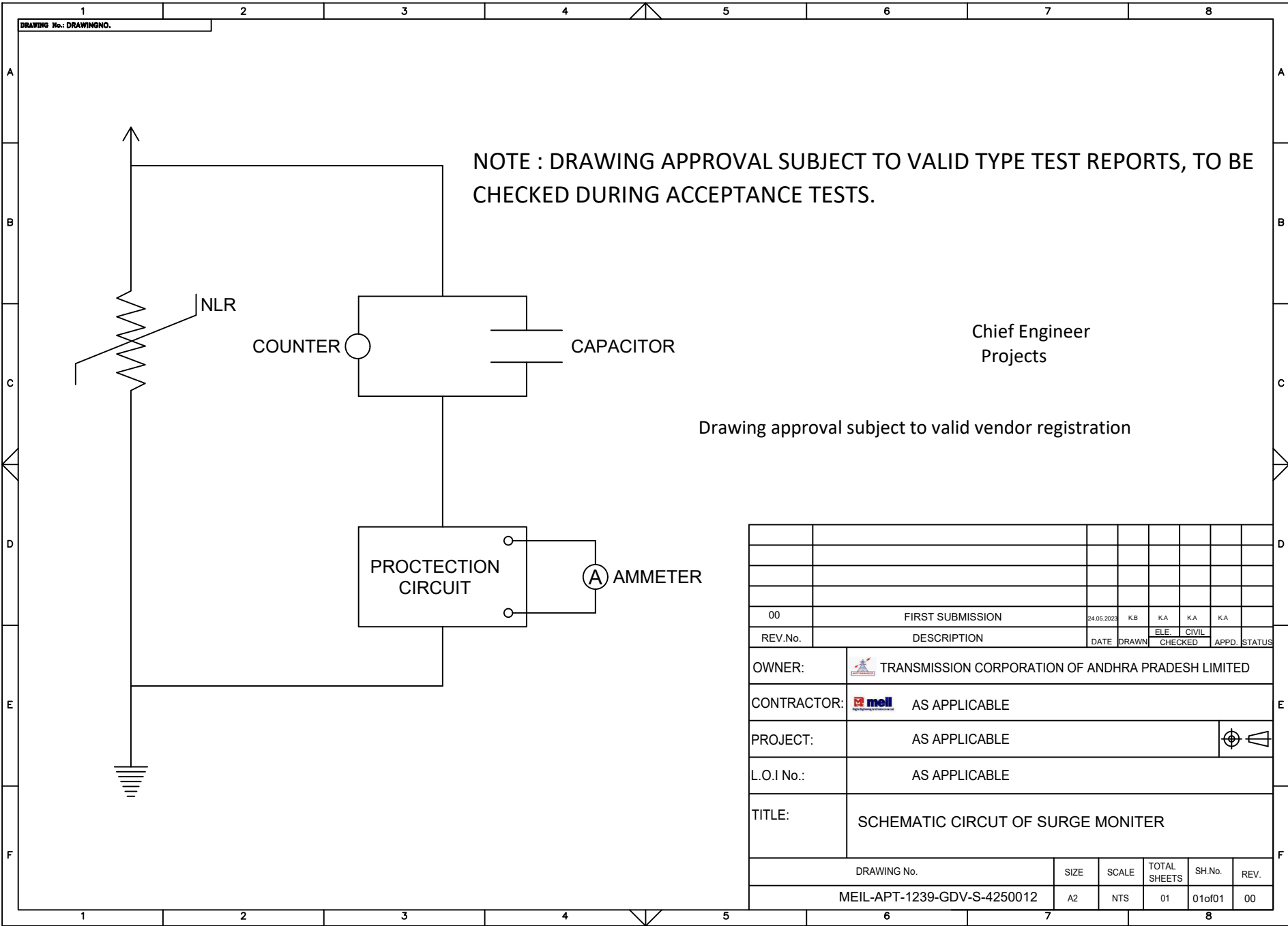

This drawing and design is the property of MEIL and must not be copied or lent without prior permission in writing



NOTE : DRAWING APPROVAL SUBJECT TO VALID TYPE TEST REPORTS, TO BE CHECKED DURING ACCEPTANCE TESTS.

Chief Engineer
Projects

Drawing approval subject to valid vendor registration

00	FIRST SUBMISSION	24.05.2023	K.B	KA	KA	KA	
REV.No.	DESCRIPTION	DATE	DRAWN	ELE. CHECKED	CIVIL	APPD.	STATUS
OWNER:		 TRANSMISSION CORPORATION OF ANDHRA PRADESH LIMITED					
CONTRACTOR:		 AS APPLICABLE					
PROJECT:		AS APPLICABLE					
L.O.I No.:		AS APPLICABLE					
TITLE:		SCHEMATIC CIRCUIT OF SURGE MONITER					
DRAWING No.		SIZE	SCALE	TOTAL SHEETS	SH.No.	REV.	
MEIL-APT-1239-GDV-S-4250012		A2	NTS	01	01 of 01	00	

This drawing and design is the property of MEIL and must not be copied or lent without prior permission in writing

DRAWING No.: DRAWINGNO.

NOTE : DRAWING APPROVAL SUBJECT TO VALID TYPE TEST REPORTS, TO BE CHECKED DURING ACCEPTANCE TESTS.

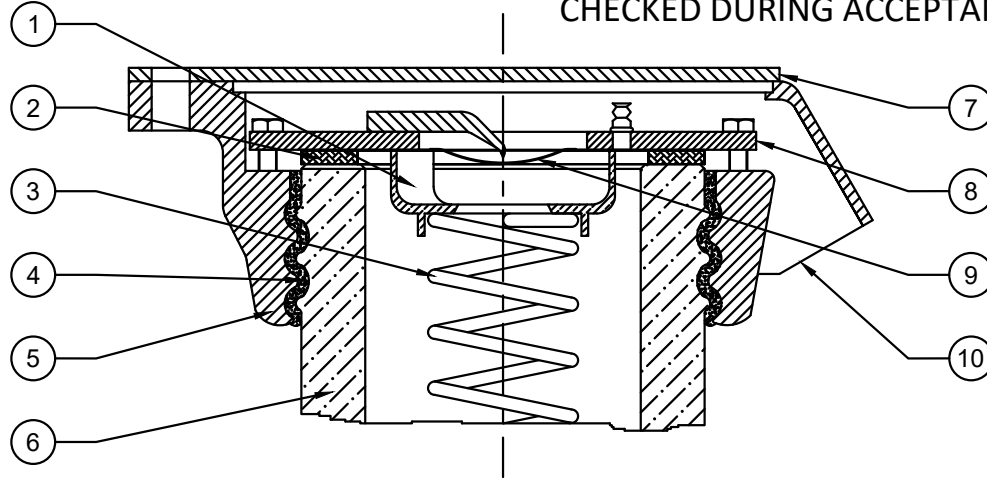

Chief Engineer
Projects

S.No.	ITEM	MATERIAL
1.	SP. SUPPORT.	ALUMINIUM
2.	RUBBER GASKET.	NEOPRENE ,5mm THICK
3.	SPRING.	SPRING STEEL
4.	SULPHUR CEMENT.	SULPHUR CEMENT
5.	CASTING.	ALUMINIUM (LM-6)
6.	BUSHING.	PORCELAIN
7.	END COVER PLATE.	ALUMINIUM
8.	COVER PLATE.	M.S (HOT DIP GALVANIZED)
9.	PRESSURE RELIEF DIAPHRAGM.	BRASS
10.	VENT PORT.	ALUMINIUM

Drawing approval subject to valid vendor registration

00	FIRST SUBMISSION	24.05.2023	K.B	K.A	K.A	K.A
REV.No.	DESCRIPTION	DATE	DRAWN	CHECKED	APPD.	STATUS
OWNER:		TRANSMISSION CORPORATION OF ANDHRA PRADESH LIMITED				
CONTRACTOR:		meil AS APPLICABLE				
PROJECT:		AS APPLICABLE				
L.O.I No.:		AS APPLICABLE				
TITLE:		PRESSURE RELIEF AND SEALING ARRANGEMENT OF MORESTER				
DRAWING No.		SIZE	SCALE	TOTAL SHEETS	SH.No.	REV.
MEIL-APT-1239-GDV-S-4220041		A2	NTS	01	01of01	00

This drawing and design is the property of MEIL and must not be copied or lent without prior permission in writing

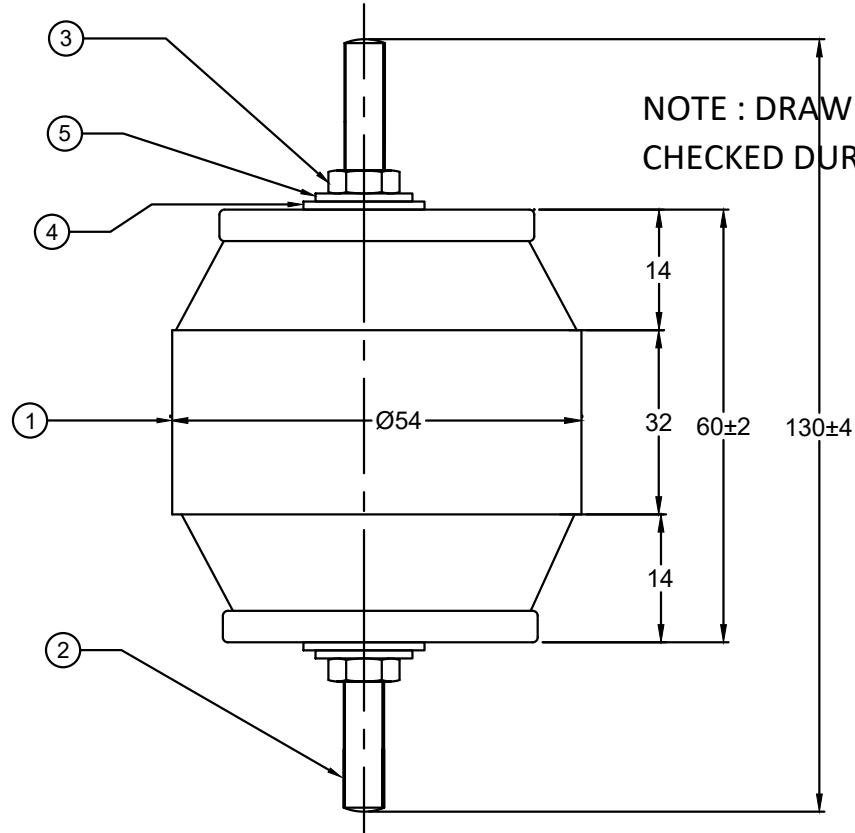

NOTE : DRAWING APPROVAL SUBJECT TO VALID TYPE TEST REPORTS, TO BE CHECKED DURING ACCEPTANCE TESTS.

Chief Engineer
Projects

Drawing approval subject to valid vendor registration

NOTE :
 1. MATERIAL : POLYCRETE
 2. HARDWARE : S.S
 3. WEIGHT : 250 Grms±10%

5	SPRING WASHER M12	S.S.	2
4	PLAIN WASHER M12	S.S.	2
3	NUT M12	S.S.	2
2	STUD M12	S.S.	2
1	INSULATOR	POLYCRETE	1
ITEM	DESCRIPTION	MATERIAL	QTY.

REV.No.	DESCRIPTION	DATE	DRAWN	CHECKED	APPD.	STATUS
01	FIRST SUBMISSION	02.06.2023	K.B	K.A	K.A	K.A

OWNER:	TRANSMISSION CORPORATION OF ANDHRA PRADESH LIMITED				
CONTRACTOR:	meil AS APPLICABLE				
PROJECT:	AS APPLICABLE				
L.O.I No.:	AS APPLICABLE				
TITLE:	SUPPORT INSULATOR - Ø54 MODEL IB-14				
DRAWING No.	SIZE	SCALE	TOTAL SHEETS	SH.No.	REV.
MEIL-APT-1239-GDV-S-6221036	A2	NTS	01	01of01	01

This drawing and design is the property of MEIL and must not be copied or lent without prior permission in writing

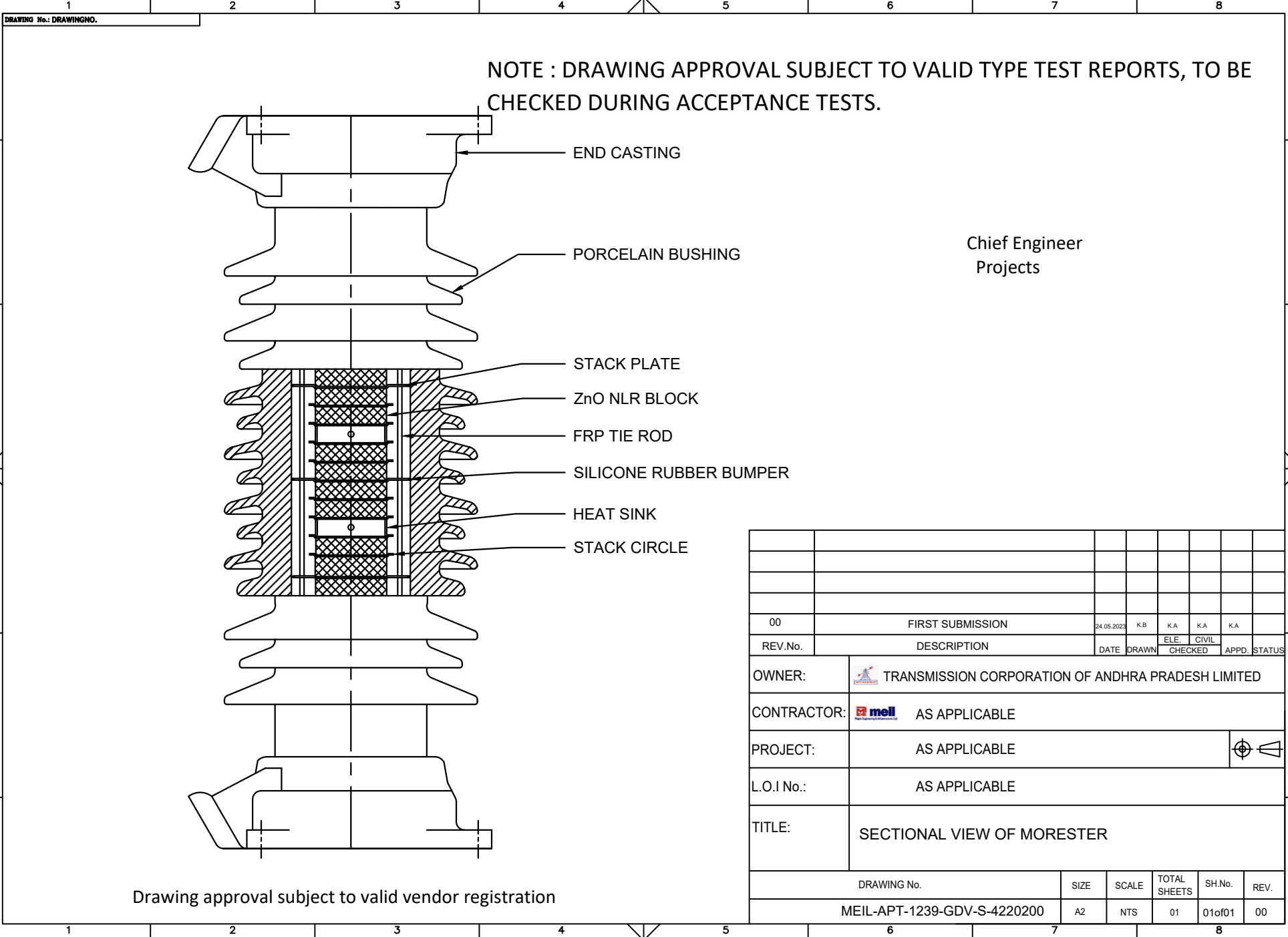

NOTE : DRAWING APPROVAL SUBJECT TO VALID TYPE TEST REPORTS, TO BE CHECKED DURING ACCEPTANCE TESTS.

Chief Engineer
Projects

Drawing approval subject to valid vendor registration

00	FIRST SUBMISSION	24.05.2023	K.B	K.A	K.A	K.A
REV.No.	DESCRIPTION	DATE	DRAWN	CHECKED	APPD.	STATUS
OWNER: TRANSMISSION CORPORATION OF ANDHRA PRADESH LIMITED						
CONTRACTOR: AS APPLICABLE						
PROJECT: AS APPLICABLE						
L.O.I No.: AS APPLICABLE						
TITLE: SECTIONAL VIEW OF MORESTER						
DRAWING No.		SIZE	SCALE	TOTAL SHEETS	SH.No.	REV.
MEIL-APT-1239-GDV-S-4220200		A2	NTS	01	01of01	00

This drawing and design is the property of MEIL and must not be copied or lent without prior permission in writing

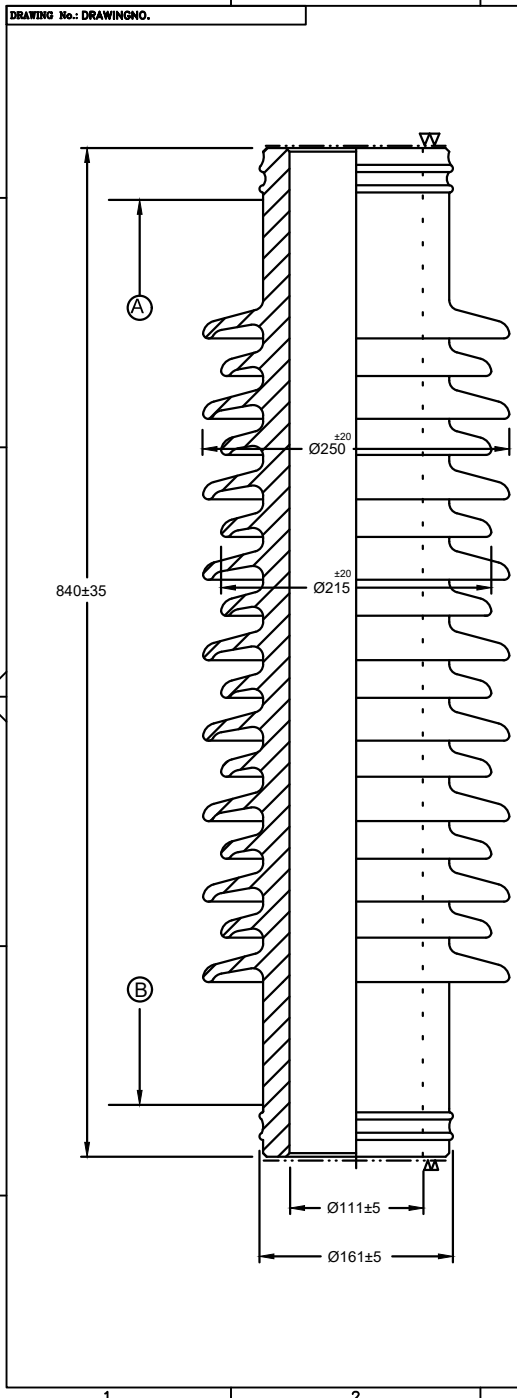

NOTE : DRAWING APPROVAL SUBJECT TO VALID TYPE TEST REPORTS, TO BE CHECKED DURING ACCEPTANCE TESTS.

Chief Engineer
Projects

Drawing approval subject to valid vendor registration

- NOTE :-
1. CREEPAGE DISTANCE FROM A TO B 2250 (NOM).
 2. SURFACES MARKED ▼ UNGLAZED, PARALLEL TO EACH OTHER AND PERPENDICULAR TO AXIS.
 3. GLAZE : DARK BROWN.
 4. BORE SHOULD BE STRAIGHT AND UNIFORM DIA.
 5. APPLICABLE STANDARD -IEC : 62155.
 6. WEIGHT : 40 Kg. ± 10%
 7. CANTILEVER STRENGTH : 500kgf
 8. FOR FLANGES Ref Drg. No. : 2210602C

00	FIRST SUBMISSION	24.05.2023	K.B	K.A	K.A	K.A	
REV.No.	DESCRIPTION	DATE	DRAWN	CHECKED	APPD.	STATUS	
OWNER:		TRANSMISSION CORPORATION OF ANDHRA PRADESH LIMITED					
CONTRACTOR:		AS APPLICABLE					
PROJECT:		AS APPLICABLE					
L.O.I No.:		AS APPLICABLE					
TITLE:		PORCELAIN BUSHING-4872					
DRAWING No.		SIZE	SCALE	TOTAL SHEETS	SH.No.	REV.	
MEIL-APT-1239-GDV-S-6220007		A2	NTS	01	01of01	00	

This drawing and design is the property of MEIL and must not be copied or lent without prior permission in writing

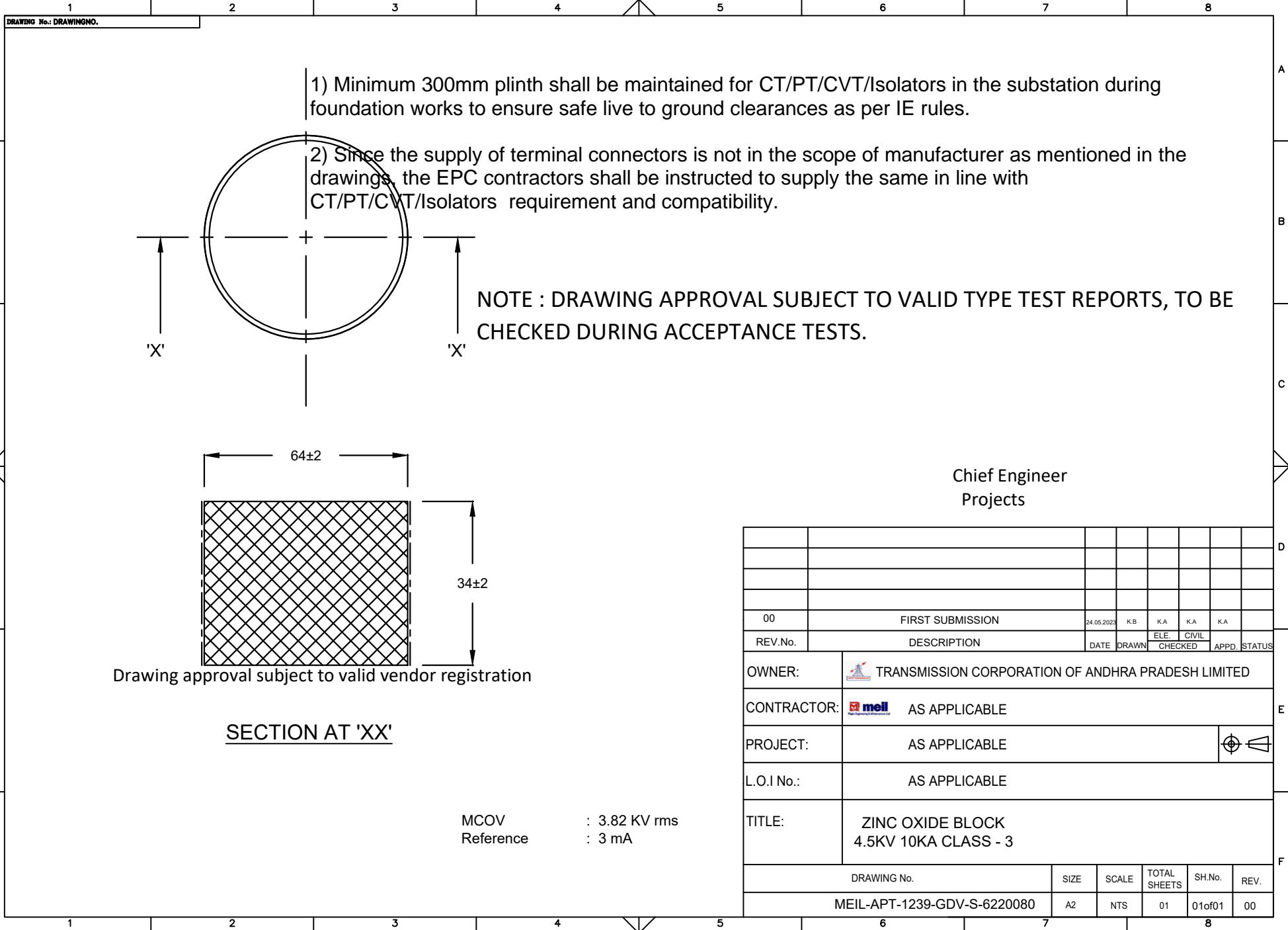

Chief Engineer
Projects

00	FIRST SUBMISSION	24.05.2023	K.B	K.A	K.A	K.A
REV.No.	DESCRIPTION	DATE	DRAWN	CHECKED	APPD.	STATUS
OWNER:		TRANSMISSION CORPORATION OF ANDHRA PRADESH LIMITED				
CONTRACTOR:		AS APPLICABLE				
PROJECT:		AS APPLICABLE				
L.O.I No.:		AS APPLICABLE				
TITLE:		ZINC OXIDE BLOCK 4.5KV 10KA CLASS - 3				
DRAWING No.		SIZE	SCALE	TOTAL SHEETS	SH.No.	REV.
MEIL-APT-1239-GDV-S-6220080		A2	NTS	01	01 of 01	00

This drawing and design is the property of MEIL and must not be copied or lent without prior permission in writing

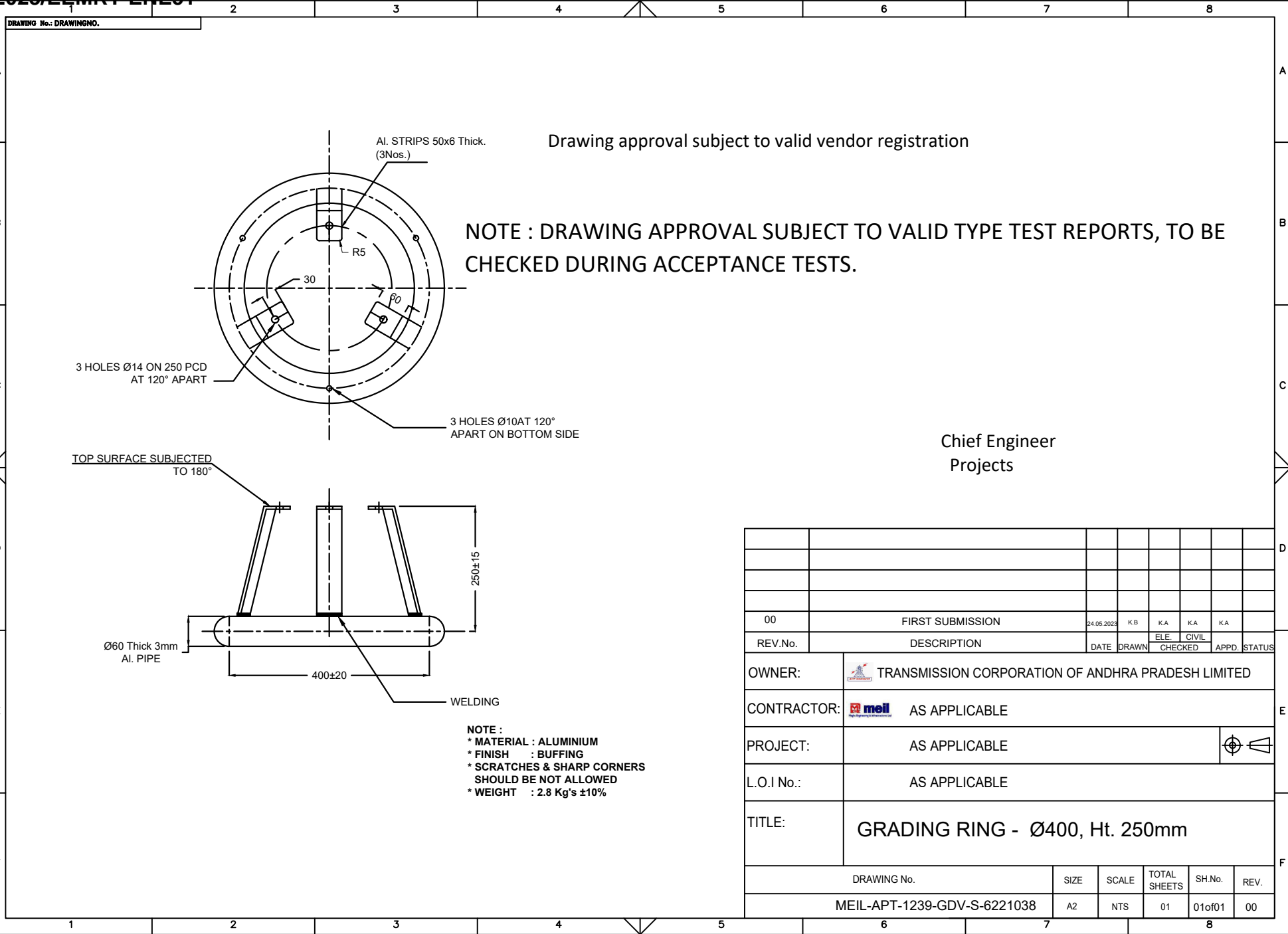

Drawing approval subject to valid vendor registration

NOTE : DRAWING APPROVAL SUBJECT TO VALID TYPE TEST REPORTS, TO BE CHECKED DURING ACCEPTANCE TESTS.

Chief Engineer
Projects

- NOTE :**
- * MATERIAL : ALUMINIUM
 - * FINISH : BUFFING
 - * SCRATCHES & SHARP CORNERS SHOULD BE NOT ALLOWED
 - * WEIGHT : 2.8 Kg's ±10%

00	FIRST SUBMISSION	24.05.2023	K.B	K.A	K.A	K.A
REV.No.	DESCRIPTION	DATE	DRAWN	CHECKED	APPD.	STATUS
OWNER:		TRANSMISSION CORPORATION OF ANDHRA PRADESH LIMITED				
CONTRACTOR:		meil AS APPLICABLE				
PROJECT:		AS APPLICABLE				
L.O.I No.:		AS APPLICABLE				
TITLE:		GRADING RING - Ø400, Ht. 250mm				
DRAWING No.		SIZE	SCALE	TOTAL SHEETS	SH.No.	REV.
MEIL-APT-1239-GDV-S-6221038		A2	NTS	01	01of01	00

This drawing and design is the property of MEIL and must not be copied or lent without prior permission in writing

NOTE : DRAWING APPROVAL SUBJECT TO VALID TYPE TEST REPORTS, TO BE CHECKED DURING ACCEPTANCE TESTS.

Chief Engineer
Projects

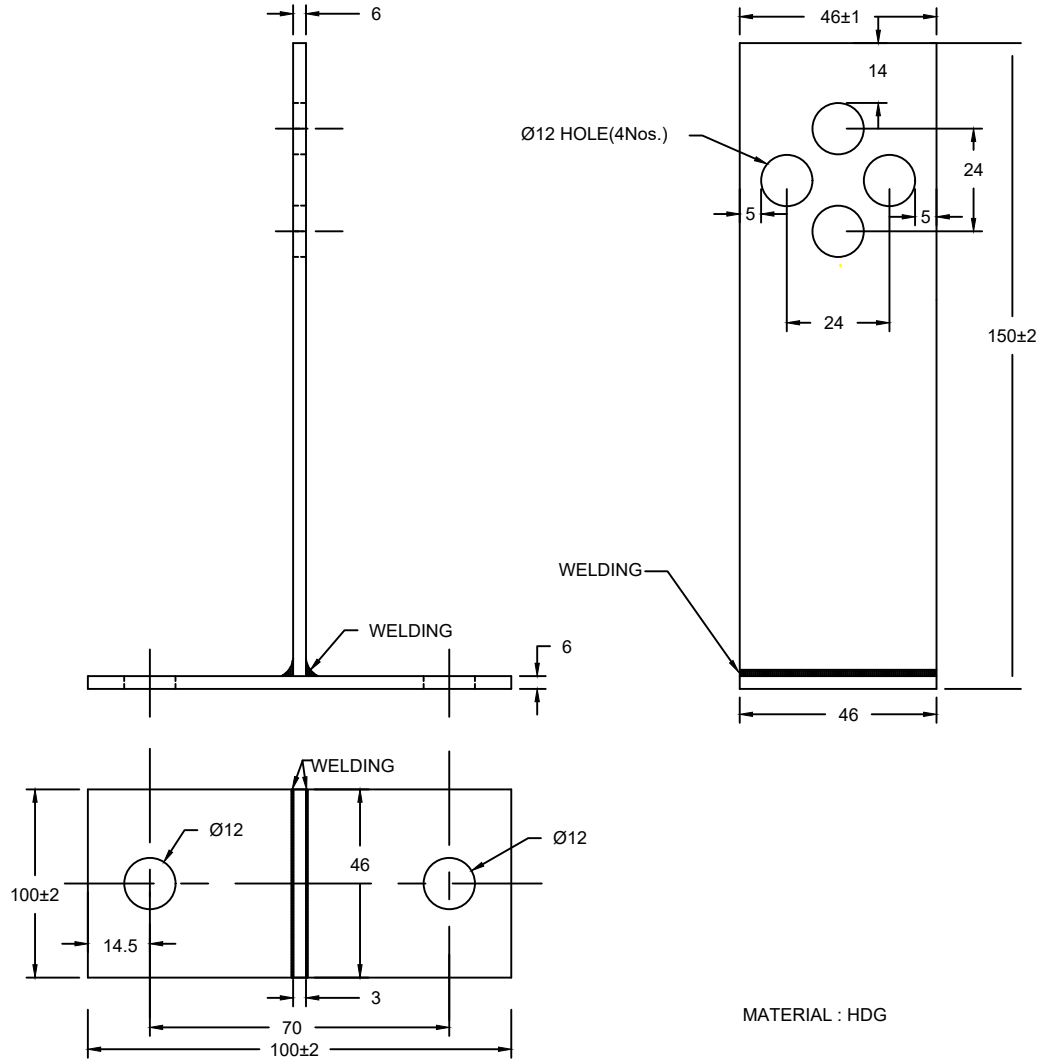

Drawing approval subject to valid vendor registration

00	FIRST SUBMISSION	24.05.2023	K.B	K.A	K.A	K.A
REV.No.	DESCRIPTION	DATE	DRAWN	ELE. CHECKED	CIVIL	APPD. STATUS
OWNER:		TRANSMISSION CORPORATION OF ANDHRA PRADESH LIMITED				
CONTRACTOR:		meil AS APPLICABLE				
PROJECT:		AS APPLICABLE				
L.O.I No.:		AS APPLICABLE				
TITLE:		S.M - MOUNTING BRACKET				
DRAWING No.			SIZE	SCALE	TOTAL SHEETS	SH.No. REV.
MEIL-APT-1239-GDV-S-4250010			A2	NTS	01	01of01 00

This drawing and design is the property of MEIL and must not be copied or lent without prior permission in writing

VOLTAGE GRADIENT (E) VOLT/mm

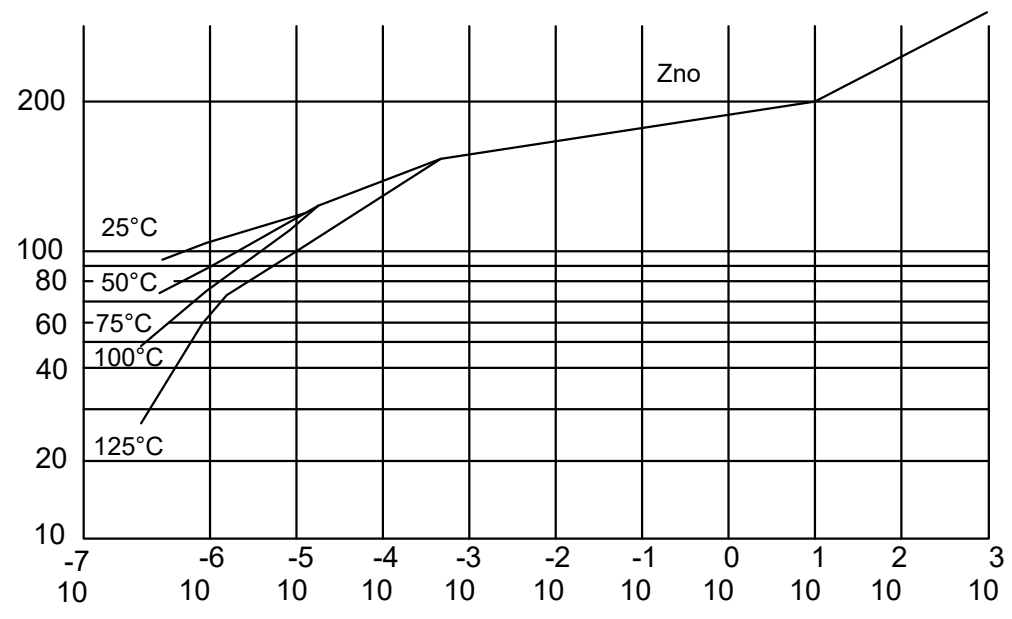

CURRENT DENSITY : AMP /CM (J) ²

Drawing approval subject to valid vendor registration

**CHIEF ENGINEER /PROJECTS
APTRANSCO/VIS/VIJAYAWADA**

00	FIRST SUBMISSION	24.05.2023	K.B	K.A	K.A	K.A
REV.No.	DESCRIPTION	DATE	DRAWN	CHECKED	APPD.	STATUS
	OWNER:	TRANSMISSION CORPORATION OF ANDHRA PRADESH LIMITED				
	CONTRACTOR:	AS APPLICABLE				
	PROJECT:	AS APPLICABLE				
	L.O.I No.:	AS APPLICABLE				
	TITLE:	CHARACTERISTIC CURVES OF ZnO ELEMENTS				
DRAWING No.		SIZE	SCALE	TOTAL SHEETS	SH.No.	REV.
MEIL-APT-1239-GDV-S-8221010		A2	NTS	01	01 of 01	00

This drawing and design is the property of MEIL and must not be copied or lent without prior permission in writing

DRAWING No.: DRAWINGNO.

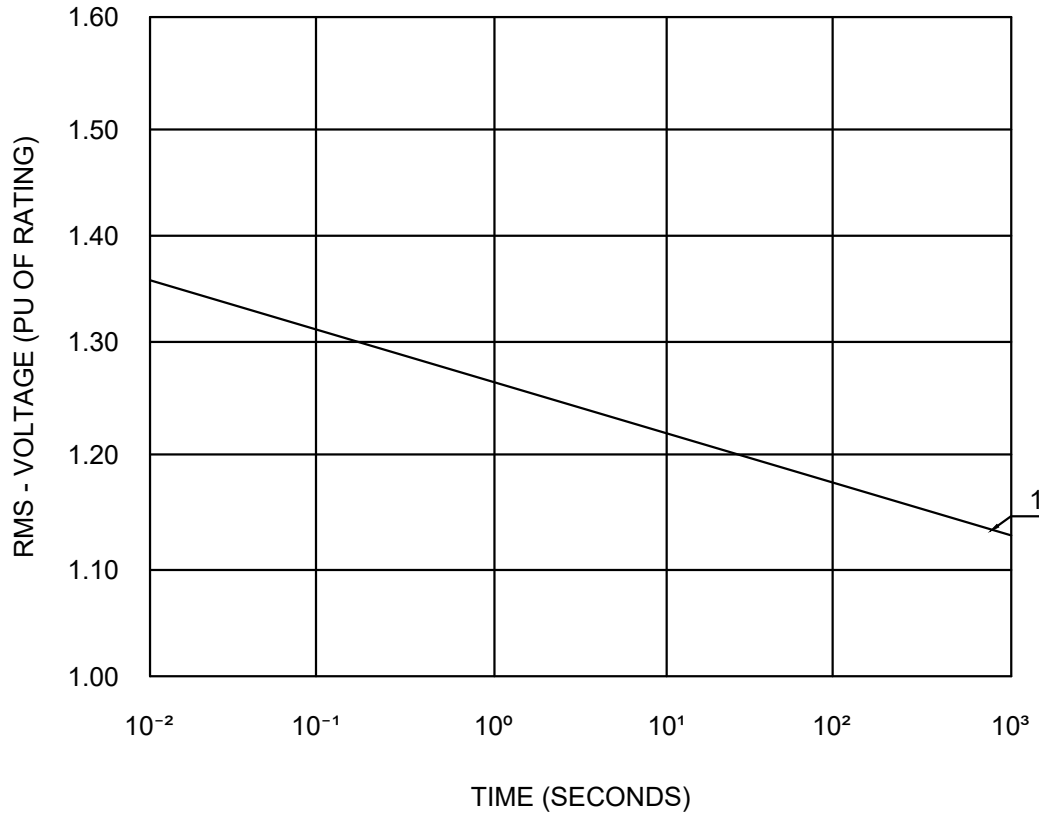

1) TOV CAPABILITY WITHOUT ENERGY ABSORPTION

Drawing approval subject to valid vendor registration

**CHIEF ENGINEER /PROJECTS
APTRANSCO/VISVIJAYAWADA**

REV.No.	DESCRIPTION	DATE	DRAWN	CHECKED	APPD.	STATUS
00	FIRST SUBMISSION	24.05.2023	K.B	K.A	K.A	K.A
				ELE	CIVIL	

OWNER:	TRANSMISSION CORPORATION OF ANDHRA PRADESH LIMITED
CONTRACTOR:	AS APPLICABLE
PROJECT:	AS APPLICABLE
L.O.I No.:	AS APPLICABLE
TITLE:	POWER FREQUENCY VOLTAGE Vs TIME CHARACTERISTICS (10 KA)

DRAWING No.	SIZE	SCALE	TOTAL SHEETS	SH.No.	REV.
MEIL-APT-1239-GDV-S-8221019	A2	NTS	01	01of01	00

DRAWING No.: DRAWINGNO.

NOTE : DRAWING APPROVAL SUBJECT TO VALID TYPE TEST REPORTS, TO BE CHECKED DURING ACCEPTANCE TESTS.

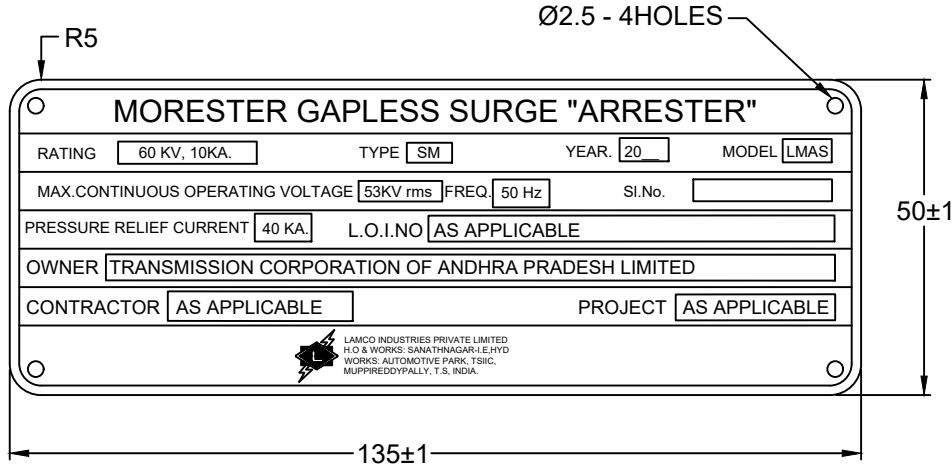

Chief Engineer
Projects

Drawing approval subject to valid vendor registration

- NOTE: ± 0.05
1. MATERIAL : THICKNESS 0.51mm (25SWG) ALUMINIUM SHEET.
 2. PRINTING :
 - a. BORDER LINE AND LETTERS WITH ON BLACK BACKGROUND.
 - b. LETTER 'L' IN MONOGRAM IS BLACK ON WHITE BACK GROUND.
 - c. RECTANGULAR BLANKS WHITE, LETTERS BLACK.
 - d. LETTERS TO BE ETCHED.

01	FIRST SUBMISSION	02.06.2023	K.B	K.A	K.A	K.A	
REV.No.	DESCRIPTION	DATE	DRAWN	ELE CHECKED	CIVIL	APPD.	STATUS
OWNER:	TRANSMISSION CORPORATION OF ANDHRA PRADESH LIMITED						
CONTRACTOR:	AS APPLICABLE						
PROJECT:	AS APPLICABLE						
L.O.I No.:	AS APPLICABLE						
TITLE:	GENERAL NAME PLATE MORESTER						
DRAWING No.		SIZE	SCALE	TOTAL SHEETS	SH.No.	REV.	
MEIL-APT-1239-GDV-S-8004401		A2	NTS	01	01of01	01	

This drawing and design is the property of MEIL and must not be copied or lent without prior permission in writing

This drawing and design is the property of MEIL and must not be copied or lent without prior permission in writing

1) Minimum 300mm plinth shall be maintained for CT/PT/CVT/Isolators in the substation during foundation works to ensure safe live to ground clearances as per IE rules.

2) Since the supply of terminal connectors is not in the scope of manufacturer as mentioned in the drawings, the EPC contractors shall be instructed to supply the same in line with CT/PT/CVT/Isolators requirement and compatibility.

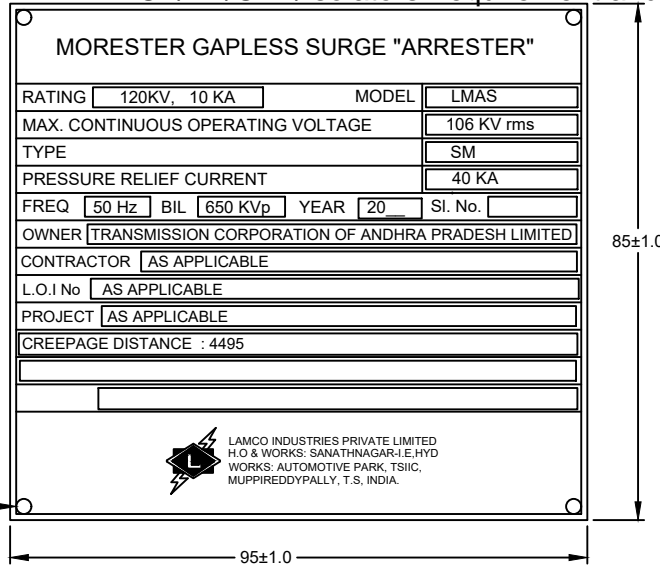

Chief Engineer
Projects

Drawing approval subject to valid vendor registration

- NOTE: ±0.05
- 1) MATERIAL: THICKNESS 0.51mm (25 SWG) ALUMINIUM SHEET.
 - 2) PRINTING:-
 - a) BORDER LINE AND LETTERS WHITE ON BLACK BACKGROUND.
 - b) LETTER 'L' IN MONOGRAM IS BLACK ON WHITE BACKGROUND.
 - c) RECTANGULAR BLANKS WHITE, LETTERS BLACK.
 - d) LETTERS TO BE ETCHED.

Drawing approval subject to valid vendor registration

REV.No.	DESCRIPTION	DATE	DRAWN	ELE. CHECKED	CIVIL	APPD.	STATUS
01	FIRST SUBMISSION	02.06.2023	K.B	K.A	K.A	K.A	
OWNER:		TRANSMISSION CORPORATION OF ANDHRA PRADESH LIMITED					
CONTRACTOR:		AS APPLICABLE					
PROJECT:		AS APPLICABLE					
L.O.I No.:		AS APPLICABLE					
TITLE:		MASTER NAME PLATE MORESTER					
DRAWING No.			SIZE	SCALE	TOTAL SHEETS	SH.No.	REV.
MEIL-APT-1239-GDV-S-8004410			A2	NTS	01	01of01	01