

9192927/2024/EEMRT-ENE51

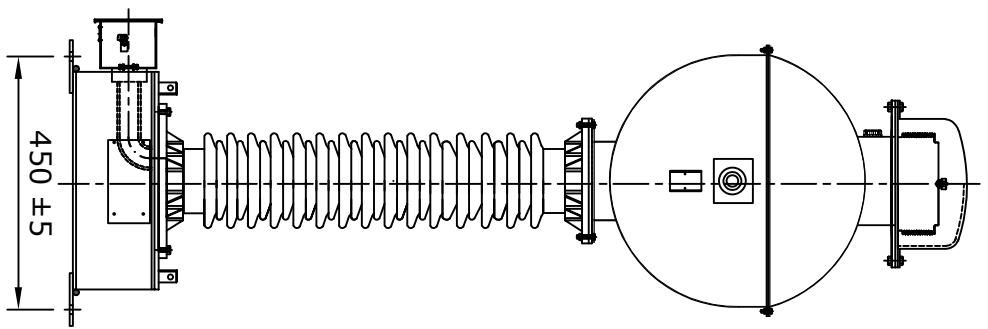
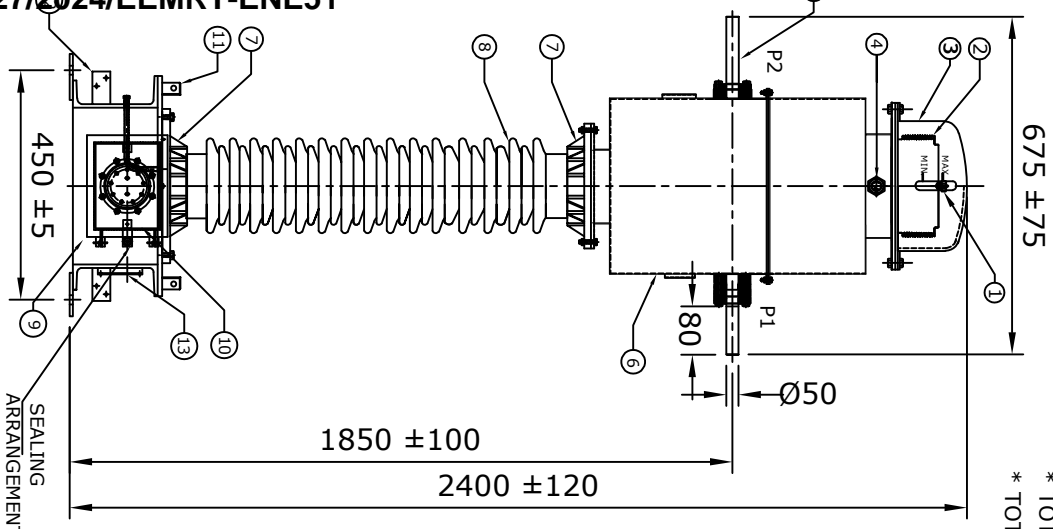
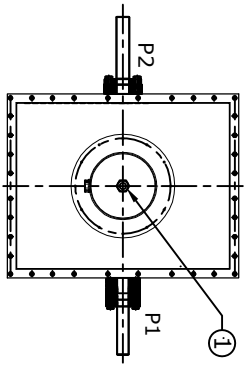

EPC works only

NOTES :-

1. MAKE OF BUSHING: IEC/MODERN/ABIL/BHEL/CJI
 2. ALL FERROUS PARTS EXPOSED TO THE ATMOSPHERE SHALL BE PAINTED WITH P.U. PAINT SHADE 631 OF IS:5
 3. ALL HARDWARE SHALL BE HOT DIP GALVANIZED.
 4. ALL GASKETS SHALL BE FIXED IN PROPERLY MACHINED GROOVES.
 5. ALL GASKETS SHALL BE MADE OF NITRILE BUTYL RUBBER.
 6. TRANSFORMER OIL AS PER IEC : 60296.
 7. PRIMARY WINDING SHALL BE BAR TYPE.
 8. SECONDARY SHALL BE TOTALLY ENCASED IN RIGID METALLIC SHELL.
- * QUANTITY OF OIL :- 90 LITRES APPROX.
 * TOTAL WEIGHT OF CT :- 350 kg. APPROX.
 * TOTAL CREEPAGE DISTANCE:- 3625 mm. MINIMUM

S.No.	DESCRIPTION	MATERIAL	QTY
1	OIL FILLING PORT	M.S	1
2	BELLOW	S.S	1
3	BELLOW DOME	M.S/AL	1
4	OIL LEVEL INDICATOR	BRASS/AL.	1
5	PRIMARY TERMINAL	ALUMINUM	2
6	OIL TANK WITH COVER	M.S	1
7	BUSHING FLANGE (CEMENTED)	GI/CI	2
8	BUSHING	PORCELAIN	1
9	BASE	M.S	1
10	SECONDARY TERMINAL BOX	M.S	1
11	LIFTING HOOK	M.S	4
12	EARTHING FLAT 80X50X8THICK.	M.S	2
13	NAME AND RATING PLATE	ALUMINUM	1
14	MOUNTING HOLE, Ø16mm ±2	M.S	4
15	OIL DRAIN PLUG	M.S	1

MOUNTING HOLE

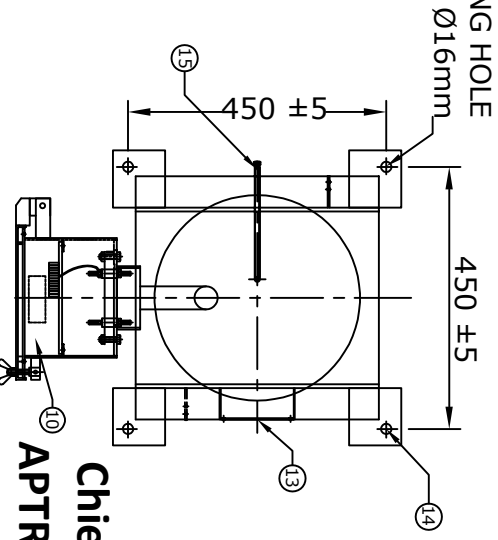

MOUNTING DETAILS

Chief Engineer/Projects
APTRANSCO/VS/Vijayawada

RATIO : 500-600-800/1-1A, 300-500-600-800/1A

UNLESS OTHERWISE SPECIFIED
 1. ALL DIMENSIONS ARE IN mm
 2. TOLERANCE WHENEVER NOT INDICATED: ±5%

REV.	FOR APPROVAL	REVISION DESCRIPTION	DATED	INITIALS
R0			30.05.2023	

DATE	NAME	MATERIAL	SEE TABLE
DGN. 30.05.2023	SFS		
DRN. 30.05.2023	K.S		
CHD. 30.05.2023	BLS		

TITLE	SCALE
GENERAL ARRANGEMENT DRAWING FOR 132KV CURRENT TRANSFORMER	N.T.S

DRG.NO	MEHRU
ME-132CT-GA-01	MEHRU ELECTRICAL & MECHANICAL ENGINEERS PVT. LIMITED

9192927/2024/EEMRT-ENE51

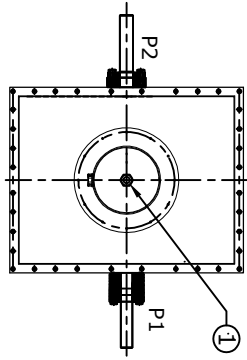

NOTES :-

EPC works only

1. MAKE OF BUSHING: IEC/MODERN/ABL/BHEL/CJI
 2. ALL FERROUS PARTS EXPOSED TO THE ATMOSPHERE SHALL BE PAINTED WITH P.U. PAINT SHADE 631 OF IS:5
 3. ALL HARDWARE SHALL BE HOT DIP GALVANIZED.
 4. ALL GASKETS SHALL BE FIXED IN PROPERLY MACHINED GROOVES.
 5. ALL GASKETS SHALL BE MADE OF NITRILE BUTYL RUBBER.
 6. TRANSFORMER OIL AS PER IEC : 60296.
 7. PRIMARY WINDING SHALL BE BAR TYPE.
 8. SECONDARY SHALL BE TOTALLY ENCASED IN RIGID METALLIC SHELL.
- * QUANTITY OF OIL :- 90 LITRES APPROX.
 * TOTAL WEIGHT OF CT :- 350 kg. APPROX.
 * TOTAL CREEPAGE DISTANCE:- 3625 mm. MINIMUM

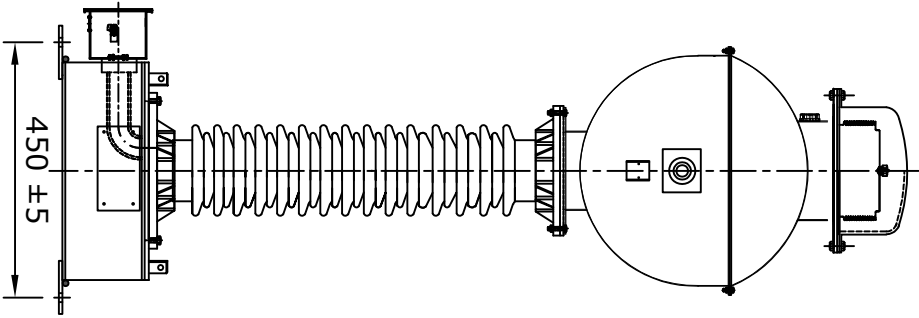
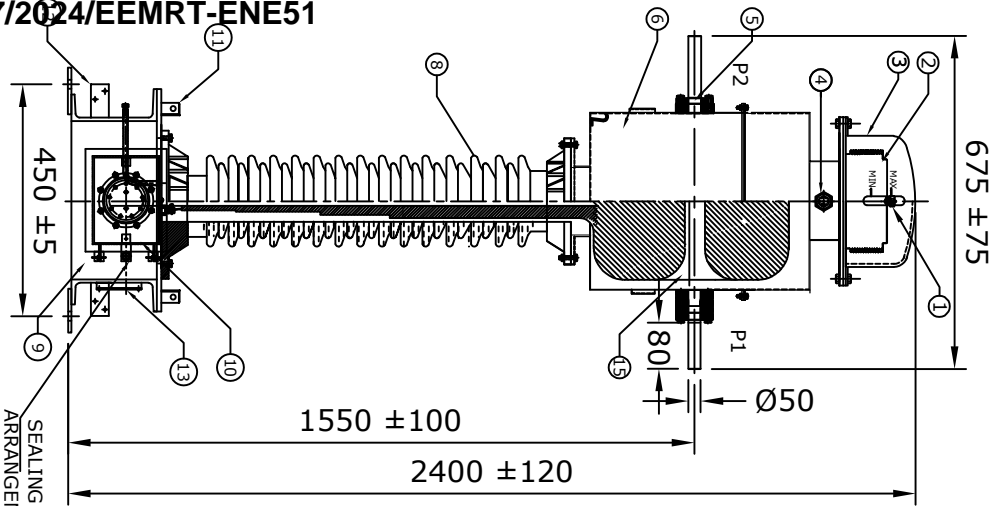

S.No.	DESCRIPTION	MATERIAL	QTY
1	OIL FILLING PORT	M.S	1
2	BELLOW	S.S	1
3	BELLOW DOME	M.S/AL.	1
4	OIL LEVEL INDICATOR	BRASS/AL.	1
5	PRIMARY TERMINAL	ALUMINIUM	2
6	OIL TANK WITH COVER	M.S	1
7	SECONDARY TERMINAL	BRASS	---
8	BUSHING	PORCELAIN	1
9	BASE	M.S	1
10	SECONDARY TERMINAL BOX	M.S	1
11	LIFTING HOOK	M.S	4
12	EARTHING FLAT 80X50X8THICK.	M.S	2
13	NAME AND RATING PLATE	ALUMINIUM	1
14	MOUNTING HOLE, Ø16mm±2	M.S	4
15	OIL DRAIN PLUG	M.S	1

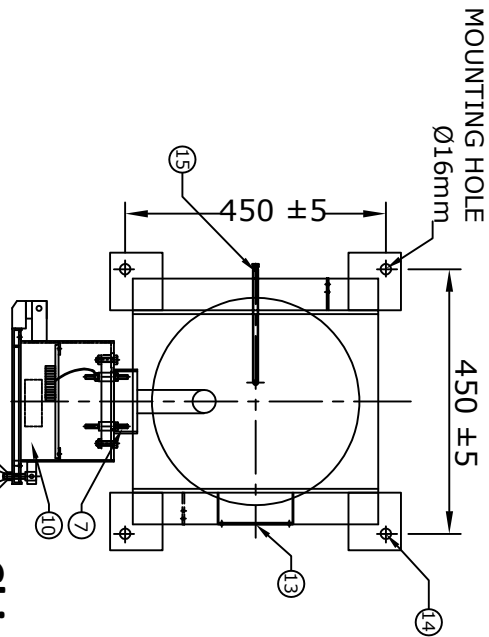

Chief Engineer/Projects
 APTRANSCO/VS/Vijayawada

RATIO : 500-600-800/1-1A, 300-500-600-800/1A

UNLESS OTHERWISE SPECIFIED
 1. ALL DIMENSIONS ARE IN mm
 2. TOLERANCE WHEREVER NOT INDICATED: ±5%

DATE	NAME	MATERIAL
DGN. 30.05.2023	SPS	SEE TABLE
DRN. 30.05.2023	K.S	
CHD. 30.05.2023	BLS	

REV.	FOR APPROVAL	DATED
R0	FOR APPROVAL	30.05.2023
REV.	REVISION DESCRIPTION	INITIALS

TITLE
 SECTIONAL ARRANGEMENT DRAWING
 FOR 132KV CURRENT TRANSFORMER

SCALE	DRG:NO
N.T.S	ME-132CT-SE-01



MEHRU ELECTRICAL & MECHANICAL ENGINEERS PVT. LIMITED



MEHRU LIVE TANK CURRENT TRANSFORMER

MADE TO IS: 16227

HIGHEST SYSTEM VOLTAGE	145 KV	INSULATION LEVEL	275/650 KV	
RATED S.T.C	40KA for 1 second	RATED FREQUENCY	50 Hz	
NOMINAL SYSTEM VOLTAGE	132 KV	CORE 1	CORE 2	CORE 3
RATIO	PRIMARY(Amp)	500-600-800	500-600-800	300-500-600-800
	SECONDARY(Amp)	1	1	1
SECONDARY TERMINALS		1S1-1S2-1S3-1S4	2S1-2S2-2S3-2S4	3S1-3S2*3S2-3S3-3S4
RATED BURDEN IN V.A		----	20 VA	10 VA
ACCURACY CLASS		PX/0.5 @5VA	5P	0.2S
ALF / ISF		----	20	≤5 @ All Ratio
Min Knee point voltage		500/600/800 V	----	----
Max Rct @ 75° C		2.5/3/4 Ω	----	----
Max Iext @ VK		60/50/37.5 mA	----	----
YEAR OF MANUFACTURE	2023	SERIAL NO.		

RATED CONTINUOUS THERMAL CURRENT: 120% OF THE RATED PRIMARY CURRENT
 * QUANTITY OF OIL :- 90 LITRES APPROX., * TOTAL WEIGHT OF CT :- 350 kg. APPROX.
 * TOTAL CREEPAGE DISTANCE :- 3625 mm. MINIMUM

MADE IN INDIA BY
MEHRU ELECTRICAL AND MECHANICAL ENGINEERS (P) LTD.
 SP-2/180,RITCO INDUSTRIAL AREA,KEHRANI, BHIWADI - RAJASTHAN - 301019

225 ±25

EPC works only

SUITABLE FOR HOT LINE WASHING CONNECTION DIAGRAM

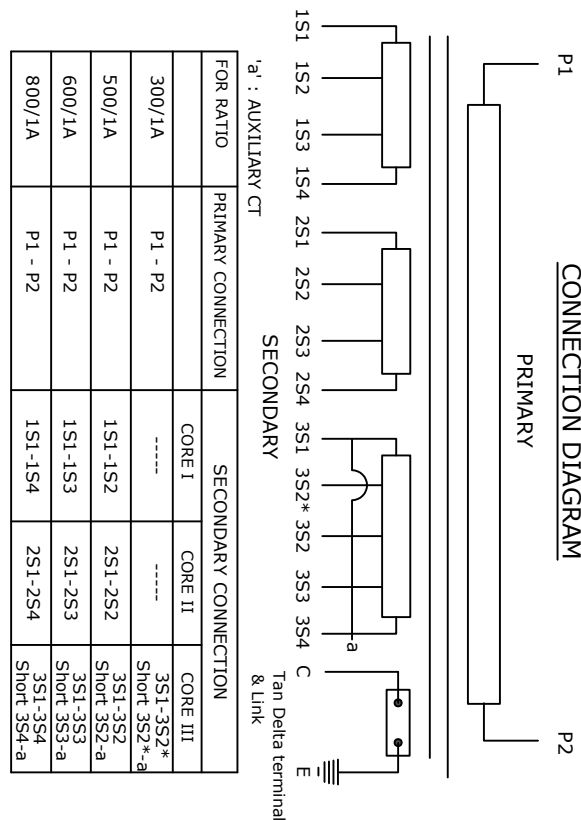

105 ±15

CAUTION
 I. SHORT CIRCUIT AND EARTH ALL SECONDARY TERMINALS ARE NOT IN USE.
 II. ALWAYS KEEP TAN DELTA TESTING TERMINAL 'C' SHORTED TO EARTH DURING OPERATION.
 III. DO NOT REMOVE EARTH LINK WHEN IN OPERATION.

- NOTES:-
1. MATERIAL OF NAME PLATE : ALUMINUM ANODIZED.
 2. THICKNESS OF NAME PLATE : 1.2 mm.
 3. SERIAL NO. SHALL BE ENGRAVED BEFORE DISPATCH.
 4. 5VA BURDEN OF DUAL CORE CLASS IS FOR 0.5 ACCURACY CLASS.
 5. FACTORY ACCEPTANCE TEST SHALL BE DONE FOR CORE 1 FOR PX & 0.5 AT 5VA

REV.	REVISION DESCRIPTION	DATED INITIALS
R0	FOR APPROVAL	30.05.2023

UNLESS OTHERWISE SPECIFIED		DATE	NAME	MATERIAL
1. ALL DIMENSIONS ARE IN mm		30.05.2023	SPS	
2. TOLERANCE WHEREVER NOT INDICATED: ±5%		30.05.2023	K.S	AL. ANODIZED
TITLE		CHD.	30.05.2023	BLS
RATIO : 500-600-800/1-1A, 300-500-600-800/1A				
NAME PLATE DRAWING FOR 132KV CURRENT TRANSFORMER				
SCALE		MEHRU ELECTRICAL & MECHANICAL ENGINEERS PVT. LIMITED		
N.T.S		MEHRU		
DRG.NO		ME-132CT-NP-01		

Chief Engineer/Projects
APTRANSCO/Vs/Vijayawada.

Guaranteed Technical Particulars for 132kV Current Transformer			
Sl. No.	Item Description	Unit	
E	CURRENT TRANSFORMER		
1	Make		Mehru Electrical & Mechanical Engineers (P) Ltd, Bhiwadi, (Raj), Inida
2	Type and Designation		Outdoor, Oil Cooled Live Tank Type, Current Transformer
3	Applicable standards		IS 16227
4	Class		A
5	Rated Voltage	132 kV	132 kV
6	Rated Primary current	Amps	500-600-800A,300-500-600-800
7	Rated Secondary current	Amps	1
8	Rated output (Burden)	VA	Core 2: 20VA, Core;3: 10VA,
9	Rated output at 0.8 lag. p.f.	VA	N/A
10	Class of accuracy		Core:1 - PX/0.5@5VA, Core: 2 - 5P, Core:-3: 0.2S
11	Accuracy limit factor		Core2: 20
12	Knee point voltage for highest tap	Volts	Core:1: 500/600/800 V
13	CT Resistance of secondary winding corrected to 75 deg.C	Ohms	Core-1: 2.5/3/4
14	Magnetising current at knee-voltage point		Core-1: 60/50/37.5mA
15	secondary limiting voltage	kV	As per IS 16227
16	Instrument security factor for winding meant for metering		Core-3 : ≤ 5 at all taps
17	One minute Power Frequency withstand test voltage of		
a)	Primary winding	kV (rms)	275
b)	Secondary winding	kV (rms)	3
18	1.2/50Hz Impulse wave withstand voltage of primary winding	kV (peak)	650
19	One minute dry P.F. withstand voltage of primary winding	kV (rms)	275
20	Creepage distance	mm	25mm/kV i.e. 3625mm (Min.)
21	Rated continuous thermal current	Amps	120% of rated primary current
22	Ratios available at highest taps		Yes
23	Rated short time thermal current	kA (rms)	40 kA
24	Rated time for above	Sec.	1
25	Rated dynamic current for primary	kA (Peak)	100 kAP
26	Class of insulation		A
27	Max. Temperature rise over ambient of 50 deg.C at any part of oil	deg.C	50c max
28			
a)	Radio interference voltage		As per IS 16227 Clause 6.11.2 $<2500\mu V$
b)	Partial discharge level		<10 pC at U_m & <5 pc at $1.2 U_m/\sqrt{3}$
29	Temp. rise after passing short time thermal current for one second	deg.C	50c max
30	Current density in primary winding at		
a)	Normal rating		0.40 Amp/sqmm (max)
b)	Short time rating of 1 Sec.		20.38 Amp/sqmm(max.)
c)	Dynamic rating		50.95 Amp/sqmm (max.)
31	Type of primary winding		Aluminium
32	No. of primary turns		1

Chief Engineer/Projects
APTRANSCO/VS/Vijayawada.

33	Type of secondary winding		Copper
34	Radio interference voltage	(micro volts)	
a)	with terminal connector mountd		<2500uV
b)	under test condition		<2500uV
35	Mounting details		450±5 x 450±5 mm
36	Source/grade of oil and standard with which it complies		EHV Grade Transformer Oil as per IS 335 /IEC 60296 of any reputed make
37	Quantity of insulating oil	Litres	90 Ltr Approx
38	Weight of Oil	kg	72 kgs Approx
39	Total Weight including Oil	kg	350 kG Approx
40	Overall dimensions (mm)		2400±120 x 675±75 x 450±5 mm
41	Wheather sealed (if so, type of sealing)		Yes, By SS BELLOW
42	Tan delta		<0.005
43	Height of supporting structure		Not in our scope of supply
44	Whether the following are enclosed with the tender		
a)	All type test reports		Yes
b)	Drawings as per the specification		Yes
c)	Technical literature for C.T.		Yes

1. Minimum 300mm plinth shall be maintained for CT/PT/CVT/Isolators/IV/LA/Breakers in the Substation during foundation works to ensure safe live to ground clearance as per IE rules.

2. Since the supply of terminal connectors is not in the scope of manufacturer as mentioned in the drawings. The EPC contractor shall be instructed to supply the same in line with CT/PT/CVT/Isolator/IVT/LA/Breakers requirement and compatibility.

Chief Engineer/Projects
APTRANSCO/VS/Vijayawada.