

Drawing approval subject to valid vendor registration

NOTE: 1. DRAWING APPROVAL SUBJECT TO VALID TYPE TEST REPORTS, TO BE CHECKED DURING ACCEPTANCE TESTS
2. FOR EPC CONTRACTS ONLY

S.No.	DESCRIPTION	QTY	MATL
1	H.T TERMINAL Ø30	1	COPPER NICKEL PLATED
2	BELLOW	1	S.S
3	PRESSURE RELEASE DEVICE	1	AL.+BAKELITE
4	BELLOW DOME	1	M.S/AL.
5	OIL LEVEL INDICATOR	1	AL./BRASS
6	OIL EXPANSION CHAMBER	1	M.S
7	BUSHING FLANGE (CEMENTED)	2	GI/CI
8	BUSHING	1	PORCELAIN
9	LIFTING LUG	4	M.S
10	NAME AND RATING PLATE	1	AL. ANODIZED
11	TANK WITH COVER	1	M.S
12	OIL DRAIN PLUG	1	M.S
13	EARTHING FLAT 80x50x8mm THICK.	2	M.S
14	SEC.& EARTHING TERMINAL BOX	1	M.S
15	MOUNTING CHANNEL 75x40	4	M.S
16	BUSHING FLAT GASKET	2	N.B.R

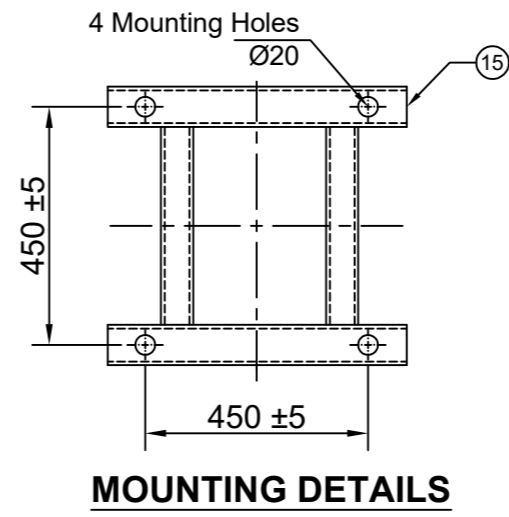
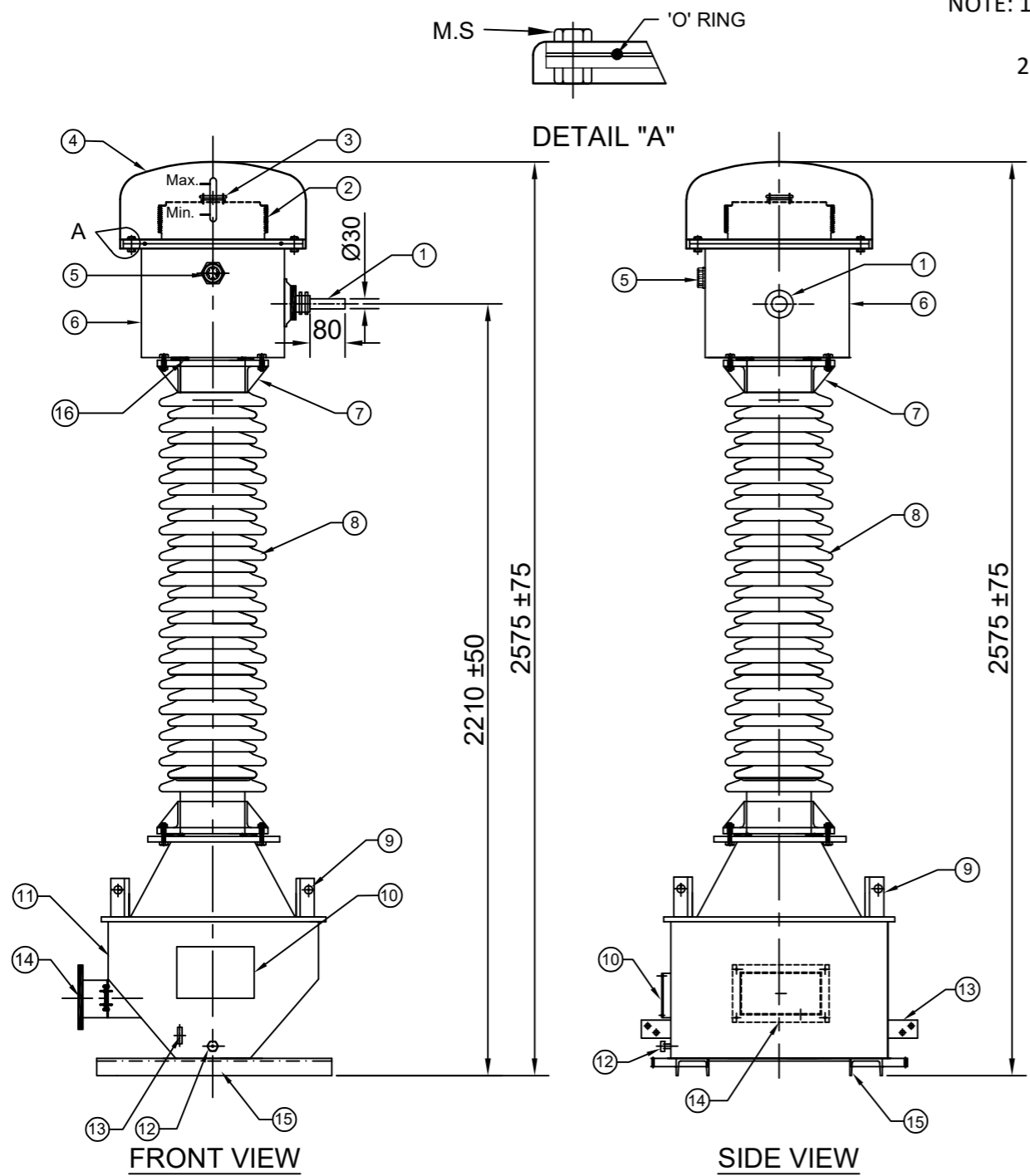

NOTES :

1. ALL FERROUS PARTS EXPOSED TO THE ATMOSPHERE SHALL BE PAINTED WITH P.U PAINT SHADE 631 OF IS: 5.
2. MAKE OF BUSHING: IEC/MODERN/BHEL/ABIL/CJI
3. TOTAL CREEPAGE DISTANCE :- 3625 mm (Min.)
4. QUANTITY OF OIL :-125 LITRES APPROX.
5. TOTAL WEIGHT OF PT : 500 KGS APPROX.
6. ALL HARDWARE SHALL BE HOT DIP GALVANIZED.
7. TRANSFORMER OIL AS PER IEC : 60296.
8. ALL GASKETS SHALL BE FIXED IN PROPERLY MACHINED GROOVES.
9. ALL GASKETS SHALL BE MADE OF NITRILE BUTYL RUBBER.

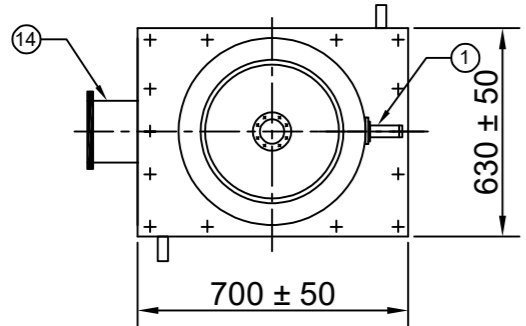

CHIEF ENGINEER
POWER SYSTEMS, PLANNING & DESIGN
APTRANSCO

REV.	REVISION DESCRIPTION	DATED INITIALS
R0	FOR APPROVAL	06.01.2021

CLIENT : TRANSMISSION CORPORATION OF ANDHRA PRADESH LIMITED				PROJECT NAME : AS APPLICABLE	
UNLESS OTHERWISE SPECIFIED	DATE	NAME	MATERIAL	<div style="border: 1px solid black; padding: 5px; display: inline-block;">MEHRU</div> MEHRU ELECTRICAL & MECHANICAL ENGINEERS (P) LTD.	
1. ALL DIMENSIONS ARE IN mm.	DGN. 06.01.2021	SPS	AS ABOVE		
2. TOLERANCE WHEREVER NOT INDICATED ±5%	DRN. 06.01.2021	AKASH			
	CHD. 06.01.2021	BLS			
	SCALE: N.T.S			TITLE : GENERAL ARRANGEMENT DRAWING FOR 132KV POTENTIAL TRANSFORMER	
SHEET No. 1 OF 7				DRG.NO ME-132PT-GA-02	

NOTE: 1. DRAWING APPROVAL SUBJECT TO VALID TYPE TEST REPORTS, TO BE CHECKED DURING ACCEPTANCE TESTS
2. FOR EPC CONTRACTS ONLY

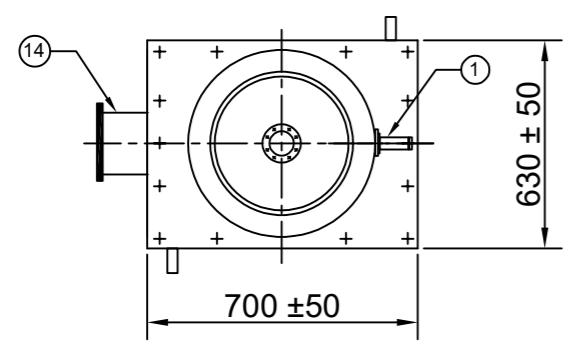
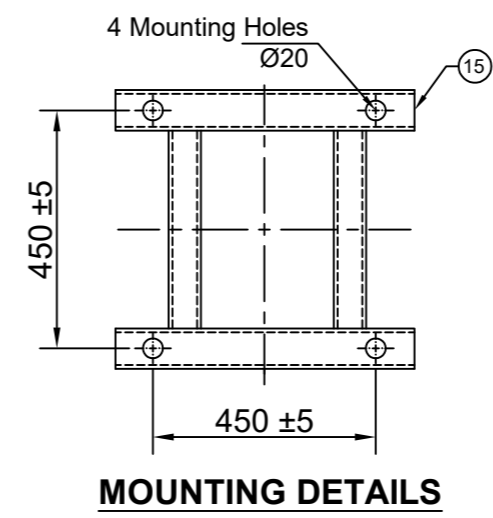
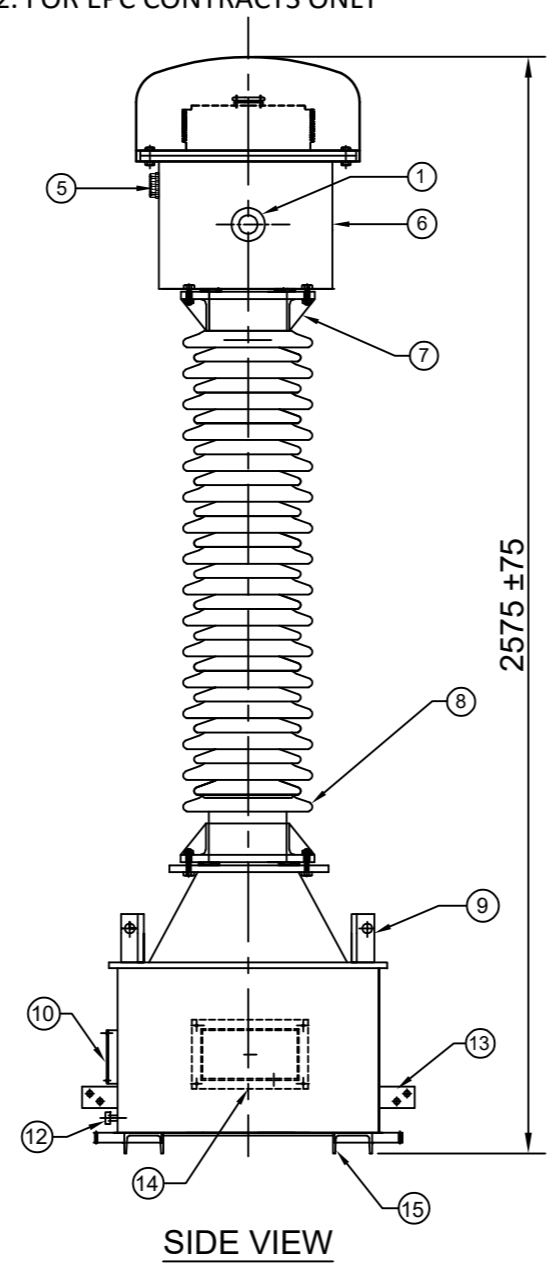
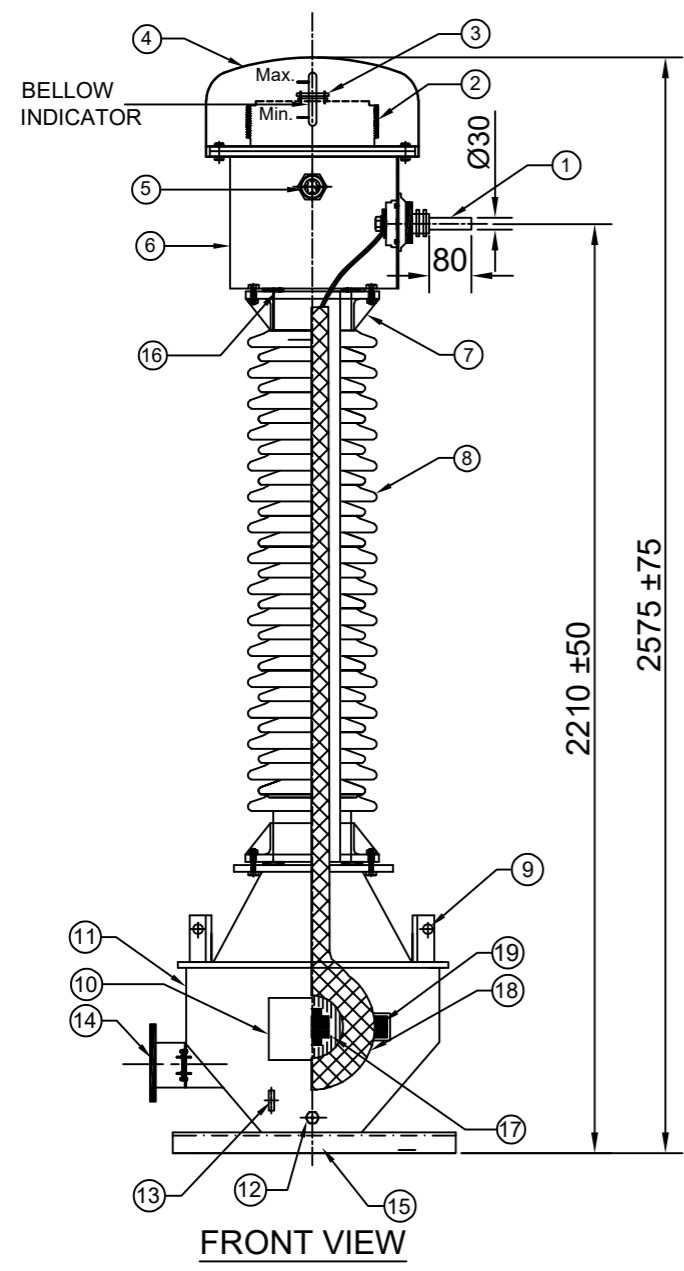

S.No.	DESCRIPTION	QTY	MATL
1	H.T TERMINAL Ø30	1	COPPER NICKEL PLATED
2	BELLOW	1	S.S
3	PRESSURE RELEASE DEVICE	1	AL.+BAKELITE
4	BELLOW DOME	1	M.S/AL.
5	OIL LEVEL INDICATOR	1	AL./BRASS
6	OIL EXPANSION CHAMBER	1	M.S
7	BUSHING FLANGE (CEMENTED)	2	GI/CI
8	BUSHING	1	PORCELAIN
9	LIFTING LUG	4	M.S
10	NAME AND RATING PLATE	1	AL. ANODIZED
11	TANK WITH COVER	1	M.S
12	OIL DRAIN PLUG	1	M.S
13	EARTHING FLAT 80x50x8mm THICK.	2	M.S
14	SEC.& EARTHING TERMINAL BOX	1	M.S
15	MOUNTING CHANNEL 75x40	4	M.S
16	BUSHING FLAT GASKET	2	N.B.R
17	LT COIL WITH PAPER INSULATION	1	COPPER
18	HT COIL WITH PAPER INSULATION	1	COPPER
19	STACK LAMINATION		CRGO

NOTES :

- ALL FERROUS PARTS EXPOSED TO THE ATMOSPHERE SHALL BE PAINTED WITH P.U PAINT SHADE 631 OF IS: 5.
- MAKE OF BUSHING: IEC/MODERN/BHEL/ABIL/CJI
- TOTAL CREEPAGE DISTANCE :- 3625 mm (Min.)
- QUANTITY OF OIL :-125 LITRES APPROX.
- TOTAL WEIGHT OF PT : 500 KGS APPROX.
- ALL HARDWARE SHALL BE HOT DIP GALVANIZED.
- TRANSFORMER OIL AS PER IEC : 60296.
- ALL GASKETS SHALL BE FIXED IN PROPERLY MACHINED GROOVES.
- ALL GASKETS SHALL BE MADE OF NITRILE BUTYL RUBBER.

CHIEF ENGINEER
POWER SYSTEMS, PLANNING & DESIGN
APTRANSCO

Drawing approval subject to valid vendor registration

R0	FOR APPROVAL	06.01.2021
REV.	REVISION DESCRIPTION	DATED INITIALS

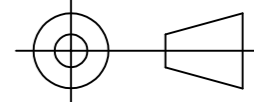
CLIENT : TRANSMISSION CORPORATION OF ANDHRA PRADESH LIMITED				PROJECT NAME : AS APPLICABLE	
UNLESS OTHERWISE SPECIFIED 1. ALL DIMENSIONS ARE IN mm. 2. TOLERANCE WHEREVER NOT INDICATED ±5%	DGN.	06.01.2021	SPS	AS ABOVE	<div style="border: 1px solid black; padding: 2px; display: inline-block;">MEHRU</div> MEHRU ELECTRICAL & MECHANICAL ENGINEERS (P) LTD.
	DRN.	06.01.2021	AKASH		
	CHD.	06.01.2021	BLS		
	SCALE:	N.T.S			
TITLE :			SECTIONAL ARRANGEMENT DRAWING FOR 132KV POTENTIAL TRANSFORMER		
SHEET No. 2 OF 7			 DRG.NO ME-132PT-SE-02		

MEHRU VOLTAGE TRANSFORMER

SR.No.		REF.STD.	IS: 16227
TYPE	Outdoor Oil Cooled	RATIO	132 kV / $\sqrt{3}$
Highest System Voltage	145 kV		110V/ $\sqrt{3}$
PHASE	Single	BURDEN	10 VA
Insulation level	275/650 kV	CLASS	0.2
Thermal Burden	10 VA	Simultaneous Burden	10 VA
Frequency	50 Hz	Type	Earthed
Voltage Factor	1.2	TIME CONT. &	1.5
		TIME FOR	30 Sec
		YEAR OF MFG.	2021

TOTAL WEIGHT OF VT : 500 KGS APPROX.
 QUANTITY OF OIL :-125 LITRES APPROX. TOTAL CREEPAGE DISTANCE :- 3625 mm (Min.)

MADE IN INDIA BY
MEHRU ELECTRICAL AND MECHANICAL ENGINEERS (P) LTD.
 SP-2/180, RIICO INDUSTRIAL AREA KHARANI EXT. BHIWADI-301019, RAJ. (INDIA)

SUITABLE FOR HOT LINE WASHING CONNECTION DIAGRAM

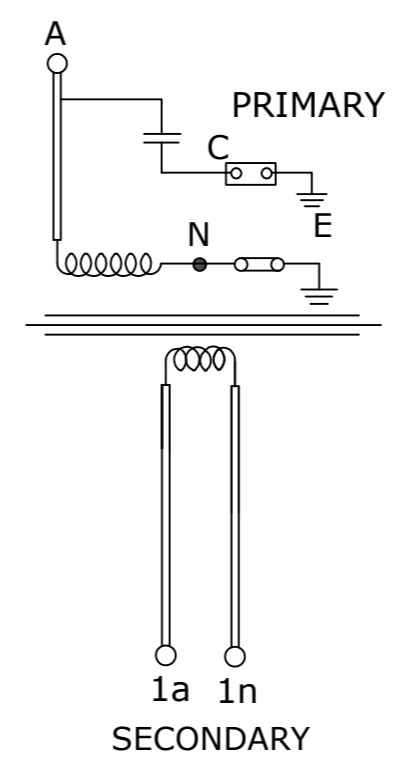

CAUTION :
 1. KEEP OPEN ALL SECONDARIES TERMINALS ARE NOT IN USE.
 2. ALWAYS KEEP NEUTRAL TERMINAL 'N' AND TAN DELTA TESTING TERMINAL 'C' SHORTED TO EARTH DURING OPERATION
 3. DO NOT REMOVE EARTH LINK WHEN IN OPERATION.

115 ±10

195 ±15

NOTES:-

1. THICKNESS OF RATING PLATE 1.2 mm
2. MATERIAL OF NAME PLATE SHALL BE AL. ANODIZED.
3. SERIAL NUMBER SHALL BE ENGRAVING BEFORE THE DISPATCH.

NOTE: 1. DRAWING APPROVAL SUBJECT TO VALID TYPE TEST REPORTS, TO BE CHECKED DURING ACCEPTANCE TESTS
 2. FOR EPC CONTRACTS ONLY

Drawing approval subject to valid vendor registration

CHIEF ENGINEER
POWER SYSTEMS, PLANNING & DESIGN
APTRANSCO

REV.	REVISION DESCRIPTION	DATED INITIALS
R0	FOR APPROVAL	06.01.2021

CLIENT : TRANSMISSION CORPORATION OF ANDHRA PRADESH LIMITED				PROJECT NAME : AS APPLICABLE	
UNLESS OTHERWISE SPECIFIED 1. ALL DIMENSIONS ARE IN mm. 2. TOLERANCE WHEREVER NOT INDICATED ±5%	DGN.	06.01.2021	SPS	MATERIAL AL.ANODIZED	 MEHRU ELECTRICAL & MECHANICAL ENGINEERS (P) LTD.
	DRN.	06.01.2021	AKASH		
	CHD.	06.01.2021	BLS		
	SCALE:	N.T.S			
TITLE :				NAME PLATE DRAWING FOR 132KV POTENTIAL TRANSFORMER	
SHEET No.				3 OF 7	
				 DRG.NO ME-132PT-NP-02	

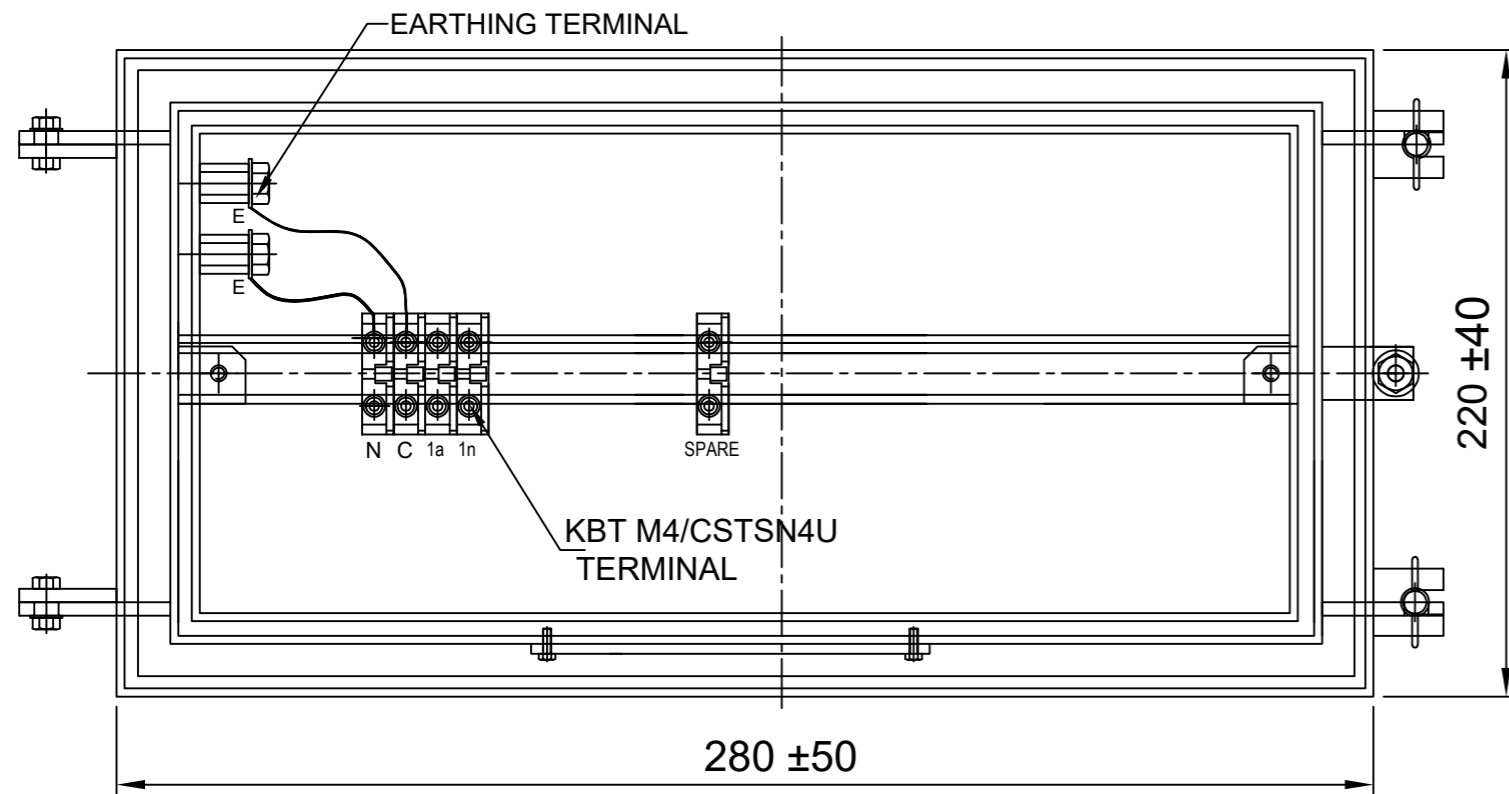

FRONT VIEW

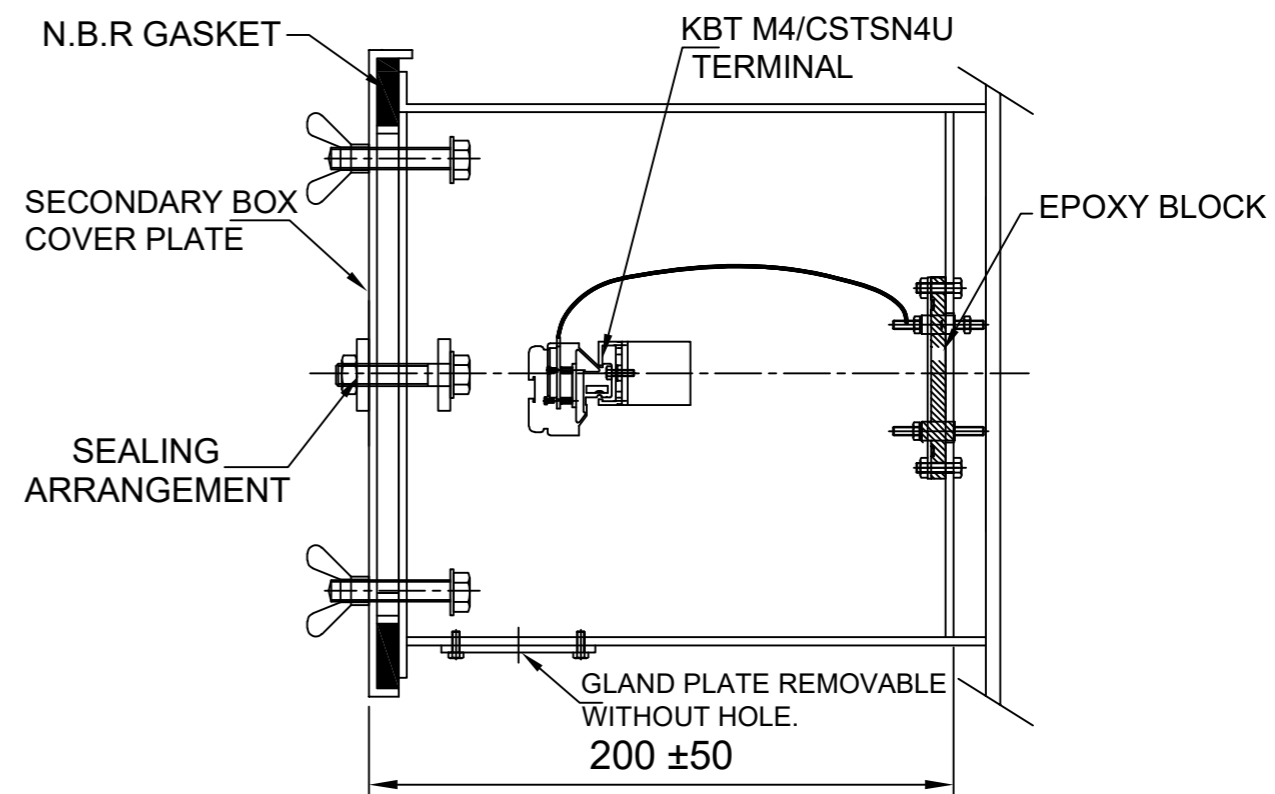

SIDE VIEW

'N' : NEUTRAL TERMINAL
'C' : TAN DELTA TESTING TERMINAL

NOTES:-

1. SECONDARY TERMINAL BOX SHALL BE PROVIDED REMOVABLE GLAND PLATE WITHOUT HOLE.
2. SECONDARY TERMINAL BOX SHALL BE PROVIDED WITH COVER.
3. M.S SHEET THICKNESS FOR TERMINAL BOX 3.0mm. & FOR COVER 2.0mm.
4. MATERIAL OF GASKET: NITRILE BUTYL RUBBER GASKET.
5. DEGREE OF PROTECTION : IP 55
6. 20% SPARE TERMINAL SHALL BE PROVIDED.

- NOTE: 1. DRAWING APPROVAL SUBJECT TO VALID TYPE TEST REPORTS, TO BE CHECKED DURING ACCEPTANCE TESTS
2. FOR EPC CONTRACTS ONLY

Drawing approval subject to valid vendor registration

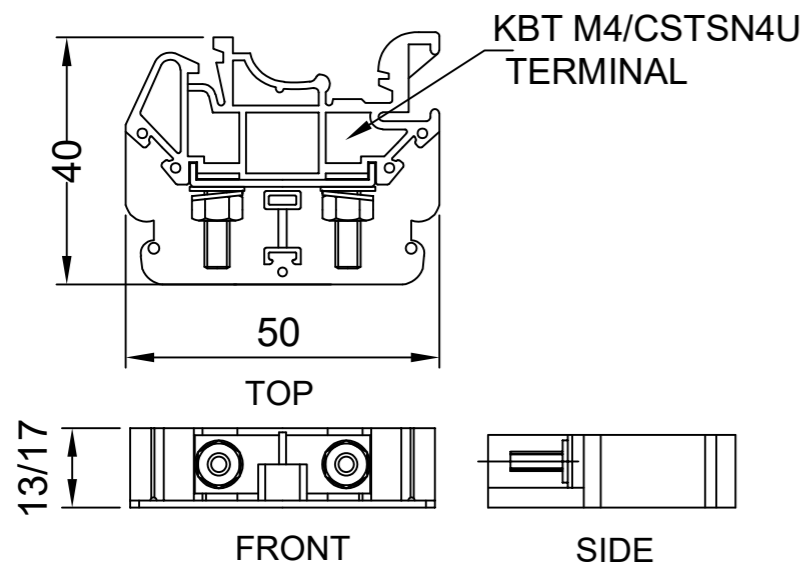

MATERIAL: POLYAMIDE
MAKE: ELMEX/CONNECTWELL
TERMINAL (DETAIL)

**CHIEF ENGINEER
POWER SYSTEMS, PLANNING & DESIGN
APTRANSCO**

REV.	REVISION DESCRIPTION	DATED INITIALS
R0	FOR APPROVAL	06.01.2021

CLIENT : TRANSMISSION CORPORATION OF ANDHRA PRADESH LIMITED PROJECT NAME : AS APPLICABLE				<div style="border: 1px solid black; padding: 2px; display: inline-block;">MEHRU</div> MEHRU ELECTRICAL & MECHANICAL ENGINEERS (P) LTD.
UNLESS OTHERWISE SPECIFIED	DATE	NAME	MATERIAL	
1. ALL DIMENSIONS ARE IN mm. 2. TOLERANCE WHEREVER NOT INDICATED ±5%	DGN. 06.01.2021 DRN. 06.01.2021 CHD. 06.01.2021 SCALE: N.T.S	SPS AKASH BLS	M.S	
TITLE : SECONDARY TERMINAL BOX DRAWING FOR 132KV POTENTIAL TRANSFORMER				
SHEET No. 4 OF 7				DRG.NO ME-132PT-STB-02

GUARANTEE TECHNICAL PARTICULARS OF 132kV POTENTIAL TRANSFORMER		
		Drawing approval subject to valid vendor registration
S.NO	DESCRIPTION	132kV
1	Type	Mehru Electrical & Mechanical Engineers (P) Ltd, Bhiwadi, (Raj), Inida
2	Manufacturer's type designation	Outdoor, Oil Cooled, Electromagnetic Type, Voltage Transformer
3	Mounting of tank (bottom)	Bottom
4	System rated voltage/highest voltage (kv)	132/145
5	Rated primary voltage (kv)	132 kV/ $\sqrt{3}$
6	Secondary winding details	
	(a)No.ofsecondary windings	1
	(b)Rated secondary voltage(V)	110V/ $\sqrt{3}$
	©Rated burden VA (simultaneous)	10VA
	(d)Class of accuracy	Wdg:1: - 0.2
7	Maximum ratio error with % rated burden and 5 % normal primary voltage	In limits as per IS 16227

8	Maximum phase angle error with % rated burden and 5 % normal primary voltage	In limits as per IS 16227
9	Temperature rise at 1.1 times rated voltage with rated burden deg.C	50deg C
10	Rated voltage factor and time	1.2 continuous & 1.5 for 30 seconds
11	Temperature rise for item-10 above deg.C	50deg C
12	Impulse withstand test voltage (kv) peak	650
13	One minute power frequency withstand test voltage on secondary (kv rms)	3
14	One minute power frequency withstand test voltage on primary (kv rms)	275
15	Total creepage distance of the bushing mm	25 mm/kV i.e. 3625 mm
16	Grade of oil	EHV IS 335/IEC 60296
17	Quantity of insulating oil (Litres)	125Ltr Approx
18	Weight of oil (kg)	100 kgs Approx
19	Total weight including oil (kg)	500kG Approx
20	Whether sealed (if so type of sealing)	Yes, SS BELLOW
21	Over all dimensions	
	Height (mm)	2575±75mm

NOTE: 1. DRAWING APPROVAL SUBJECT TO VALID TYPE TEST

4714164/2021/EEMRT-ENE51 REPORTS, TO BE CHECKED DURING ACCEPTANCE TESTS

2. FOR EPC CONTRACTS ONLY

	Length (mm)	450±5mm
	Breadth (mm)	450±5mm
22	Weight of Steel	115 kgs (Approx.)
	Weight of copper	11 kgs (Approx.)
a)	Radio interference voltage	As per IS 16227 Clause 6.11.2 <2500uV
b)	Partial discharge level	<10 pC at Um & <5 pc at 1.2Um/√3
	Tan delta	<0.005

**CHIEF ENGINEER
POWER SYSTEMS, PLANNING & DESIGN
APTRANSCO**

Drawing approval subject to valid vendor registration