

7459819/2023/RENT/GEN/51 PERFORMANCE TESTS.

PAVANI POWER SYSTEMS PVT. LTD.,



TRANSMISSION CORPORATION OF ANDHRA PRADESH LTD.

GUARANTEED TECHNICAL PARTICULARS FOR 145KV 1200A DB WITH EARTH SWITCH ISOLATOR

S.No	DESCRIPTION	GUARANTEED VALUE
1	Type / Installation	"DBR" Double Break Center post rotating type" / Outdoor installation
2	Manufacturer's Name and Country of Manufacture	PAVANI POWR SYSEM PVT LTD. INDIA
3	Standards according to which the isolators are manufactured	IS: 9921 - Part-I to V / IEC:62271-102
4	Miximum design voltage at which the isolator can operate (kV)	145
5	Frequency (Hz)	50
6	Rated voltage (kV)	145
7	Maximum current that can be safely interrupted by the isolator Inductive (A & % PF) Capacitive (A & % PF)	Inductive- 0.7 Amps at 0.15 p.f. Capacitive- 0.7 Amps at 0.15 p.f.
8	Continuous current rating Nominal (Amps) under site conditions	1200
9	Rated short time current	MAIN SWITCH / EARTH SWITCH.
	i) For 3 seconds (kA rms)	40KA 3.Sec.
	ii) For 1 second (kA rms)	Not Applicable
	iii) Rated peak short time current (kVp)	100
10	Current density at the minimum cross-section of	Contact sizes indicated in Annexure - III of specification & as per the property of materials.
	a) Moving blade (Amps/ Sq.mm) Cu. Tube	2.0 Amps / Sq.mm for HDE Cu. Tube
	b) Terminal pad : Aluminum Flat	1.0 Amp/ Sq.mm for EC grade Alu. Flat
	c) Contacts : Cu.Flat	1.6 Amps/Sq.mm for HDE Cu. Flat
	d) Terminal connector : Aluminm Casting	1.0 Amps/Sq.mm for Alu. Alloy.
11	Maximum Temp. Rise of current carrying parts when carrying rated current continuously (deg.C)	Within the specified limits of IS: 9921 - PartII/ IEC-62271-102
13	Insulation Levels	
	i) Impulse withstand voltage (kV peak) phase to earth across isolating distance:	650/ 750 kV peak
	ii) Switching surge withstand voltage (kV peak) phase to earth across isolating distance	Not applicable
	iii) Power frequency withstand voltage (kV rms) Phase to earth across isolating distance	275/ 315 kV rms
14	Minimum clearance in air	
	i) Between poles (mm)	2700mm (For Phase spacing of 3000 mm)
	ii) Between live parts and earth (mm)	1300 mm (Equal to dry arcing distance of insulators selected)
	iii) Between live parts when switch is open	
	a) On the same pole (mm)	2135
	b) Between adjacent poles (mm)	3000

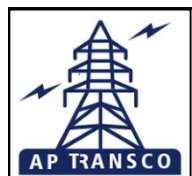

TRANSMISSION CORPORATION OF ANDHRA PRADESH LTD.

GUARANTEED TECHNICAL PARTICULARS FOR 145KV 1200A DB WITH EARTH SWITCH ISOLATOR

S.No	DESCRIPTION		GUARANTEED VALUE
15	Rated mechanical terminal load		:
	i)	Load along the terminal connector side (Kg.)	: 51
	ii)	Load across the terminal connector side (Kg.)	: 18
16	Torque required to operated the switch in Kg.m		: 35
17	Design and Construction		:
	i)	No. of insulators per pole	: Three
	ii)	No. of breaks per pole	: Two
	iii)	Type of closing / opening mechanism (Horizontal/Vertical break straight etc.)	: Horizontal break for isolator
	iv)	Contacts	:
	a)	Material and grade	: Hard drawn electrolytic copper flat, contact area is silver plated (15 Microns)
	b)	Cross-sectional area (mm)	: 768 Sq.mm for 1200 Amps
	v)	Moving blades	:
	a)	Material and grade	: Hard drawn electrolytic copper flat, contact area is silver plated (15 Microns)
	b)	Cross-sectional area (mm)	: 643 Sq.mm for 1200 Amps
	vi)	Contact support	:
	a)	Material and size of channel/block	: 4 mm thick, MS HDG
	b)	Material and size of plate	: 6 mm thick, MS HDG Plate
	vii)	Rain hood - Material grade and size	: 1mm GI Sheet
	viii)	Turn and twist mechanism	:
	a)	Material and size of clamps	: 40 x 8 mm thick, MS HDG flat.
	b)	Maerial size of springs	: 3.0 mm Stainless steel wire
	c)	Whether springs are encased	: Not encased.
	ix)	Nuts and Bolts	:
	a)	Size, material and grade in live parts	: Less than M12: Stainless steel
	b)	Size, material and grade in other parts	: M12 and above: MS HDG.
	x)	Insulator base plate / channel material and size of plate below insulators	: 225 x 75, 10mm Thk MS HDG channel
	xi)	Bearings	:
	a)	Material and size of housing	: MS HDG suitable for 40 ID taper roller/ ball bearing.
	b)	No. of bearings, location and size	: 2 Nos . Below centre rotating post insulator.

1). Minimum 300 mm Plinth shall be maintained for Current transformers in the substation during foundation works to ensure safe live to ground clearances as per IE rules.

2). Since the supply of terminal connectors is not in the scope of CT Manufacturer as mentioned in the drawings, the EPC contractors shall be instructed to supply the same in line with the CT requirement and compatibility.

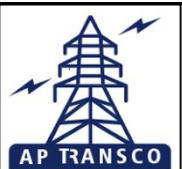

TRANSMISSION CORPORATION OF ANDHRA PRADESH LTD.

GUARANTEED TECHNICAL PARTICULARS FOR 145KV 1200A DB WITH EARTH SWITCH ISOLATOR

S.No	DESCRIPTION	GUARANTEED VALUE
xii)	Tandem pipe	:
	a) Size, class and No. of pipes	: 32mm NB Class B,GI Pipe for Main switch-2Nos for Earth switch-1No.
	b) Size of shackle, screw	: Suitable for 32mm NB GI Pipe
	c) No. of bearings/bush and its material and size	: Not applicable
xiii)	Type of interlock	: Electrical interlock between isolator and correspondin breaker / Mechanical interlock between M.S & E.S.
xiv)	Down pipe size and class	: 50 NB Class B GI pipe
xv)	Type of universal/swivel joint	:
	a) Between bearing and down pipe	: Universal Joint (MS HDG)
	b) Between down pipe and operating mechanism	: Vernier flange
xvi)	Operating mechanism	: Manual operated mechanism for main switch and earth switch.
	a) Control cabinet material and thickness	: 3.mm THK Aluminum Sheet
	b) Degree of protection	: IP: 55 as per IS: 2147
	c) Type, size and No. of cable glands	: Double compression type 2Nos. 19 mm (Contractor scope of supply)
	d) Whether removable gland plate provided	: Yes, provided.
	e) Make, type, rating and quantity of motors	: Not applicable
	f) Auxiliary blocks	: 6 NO + 6 NC Contacts for main switch, & earth switch. 10 Amps, 2 A DC Breaking with 2A - 1 No.
	g) Terminal blocks	: UBT-4
	h) Insulated wires	: 1100 V grades, 2.5 Sq. mm PVC cable
	i) HRC Fuse	: FTC / GE / S&S or Eqvt.
	j) Space Heater	: Not applicable
	k) Interlocks	: Not applicable
xvii)	Base:	:
	a) Size of steel section used	: 145x80x5mm Rectangle box profile(M.S.HDG)
	b) Overall sie	: 145 x 80 x 2400 mm
	c) Total weight.	: 65Kgs (Approx.) one pole
	Name of the firm	: For Pavani Power Systems Pvt. Ltd.
	Signature of Bidder	: 
	Designation & Seal	: (T. SESHAGIRI RAO) Managing Director
	Date	: 18-05-2023

NOTE : DRAWING APPROVAL SUBJECT TO VALID TYPE TEST REPORTS, TO BE CHECKED DURING ACCEPTANCE TESTS.

7459819/2023/FEMRT-ENE51

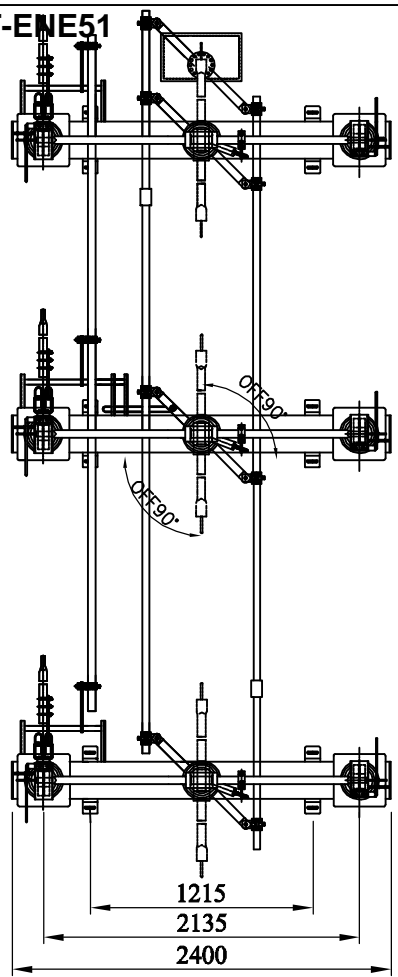
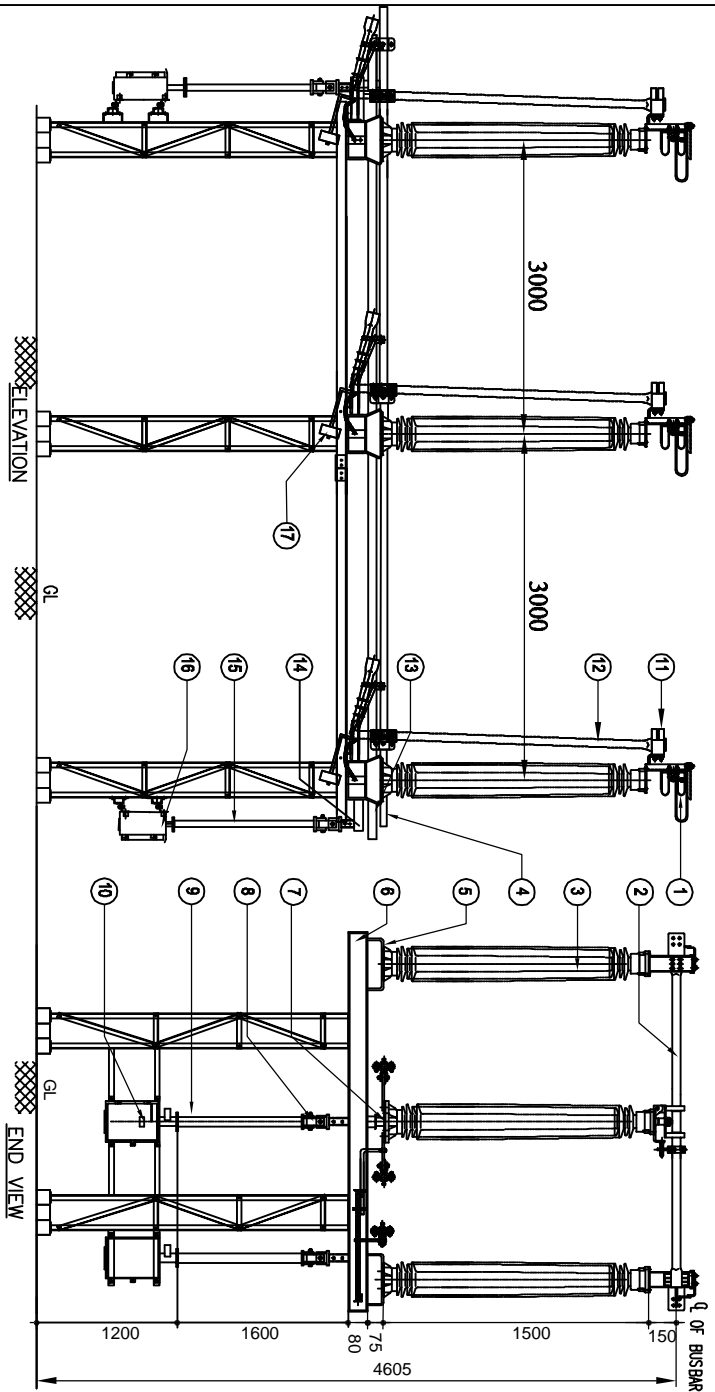

INSULATOR FIXING DETAILS

Drawing approval subject to valid vendor registration

Nos. 818HOLES ON 184 P.C.D.



ANOS. 916 TAP HOLES ON 127 P.C.D.

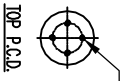

1215

2135

2400

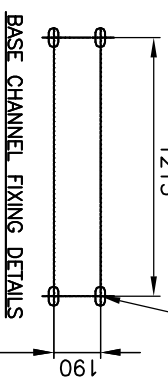

Chief Engineer
Projects

PART LIST:

1. FIXED CONTACT ASSEMBLY
2. MOVING CONTACT ASSEMBLY
3. INSULATOR STACK (COSTUMER SCOPE)
4. TANDEM PIPE FOR ISOLATOR (32NB, CLASS "B" G.I PIPE)
5. ELEVATOR CHANNEL (220 X 75MM X 10MM THK M.S HDG)
6. BASE CHANNEL (145 X 80 X 5MM THK. M.S HDG)
7. ROTATING STOOL BASE WITH LEVER ARM & CLAMP (M.S HDG)
8. OPERATING PIPE CONNECTING BUSH (M.S HDG)
9. DOWN PIPE FOR ISOLATOR (50NB CLASS"B" G.I PIPE)
10. MANUAL OPERATING MECHANISM FOR ISOLATOR
11. E.S FIXED CONTACT ASSEMBLY
12. E.S MOVING CONTACT ASSEMBLY
13. TANDEM PIPE FOR E.S (32NB CLASS "B" G.I PIPE)
14. TOP OPERATING MECHANISM FOR EARTH SWITCH (M.S HDG)
15. DOWN PIPE FOR E.S (50NB CLASS "B" G.I PIPE)
16. MANUAL OPERATING MECHANISM FOR E.S
17. COUNTER WEIGHT FOR E.S (Per pole 5Kgs Approx.)

REFERENCE DRAWINGS:

1. FOR ISOLATOR CONTACT ASSEMBLY (1200 AMPS)
2. FOR EARTH SWITCH CONTACT ASSEMBLY
3. FOR MANUAL OPERATED MECHANISM FOR MAIN SWITCH
4. FOR MANUAL OPERATED MECHANISM FOR EARTH SWITCH
5. FOR MECHANICAL INTERLOCK BETWEEN ISOLATORS AND EARTH SWITCH.
6. FOR NAME PLATE DETAILS

NOTE: 1. ALL DIMENSIONS ARE IN MILLIMETERS

2. THE INDICATED DIMENSIONS ARE SUBJECT TO THE MANUFACTURING TOLERANCE:

- UP TO 50mm -----±3%; 51 TO 100mm ----- ±2%
- 101 TO 300mm -----± 1%; ABOVE 300mm -----±0.5%
- 3. SHORT TIME CURRENT RATING 40KA rms. FOR 3 Sec.
- 4. MIN. CREEPAGE DISTANCE 3625 mm(25mm/KV)
- 5. APPLICABLE STANDARD : IEC: 62271-102
- 6. ALL FERROUS PARTS ARE HOT DIP GALVANIZED (85MICRONS)

For Pavani Power Systems Pvt. Ltd.

(T. SESHAGIRI RAO)
Managing Director

TRANSMISSION CORPORATION OF
ANDHRA PRADESH LTD



TITLE:
145KV, 1200A, TP, HDB, RT, ISOLATOR WITHOUT E.S.
(WITH MANUAL OPERATING MECHANISM)

REVISIONS	D	C	B	A
SCALE: NLT				
DATE	18-05-2023			
DRAWN				
CHECKED				
APPROVED				
SHEET	01 OF 07			
DESIGN:	PPSP-APT-GAD-44-01			



PAVANI POWER SYSTEMS PVT.LTD.
Plot No. 06/065/4/6, K.K. OVERSEAS SOCIETY,
D.A. DULAPALLY, QUTHUBULLAPUR MANDAL,
KOMURU FORT, HYDERABAD - 500100.
MEDICAL MARKAGER DIST. TELANGANA

FIXED CONTACT ASSEMBLY:

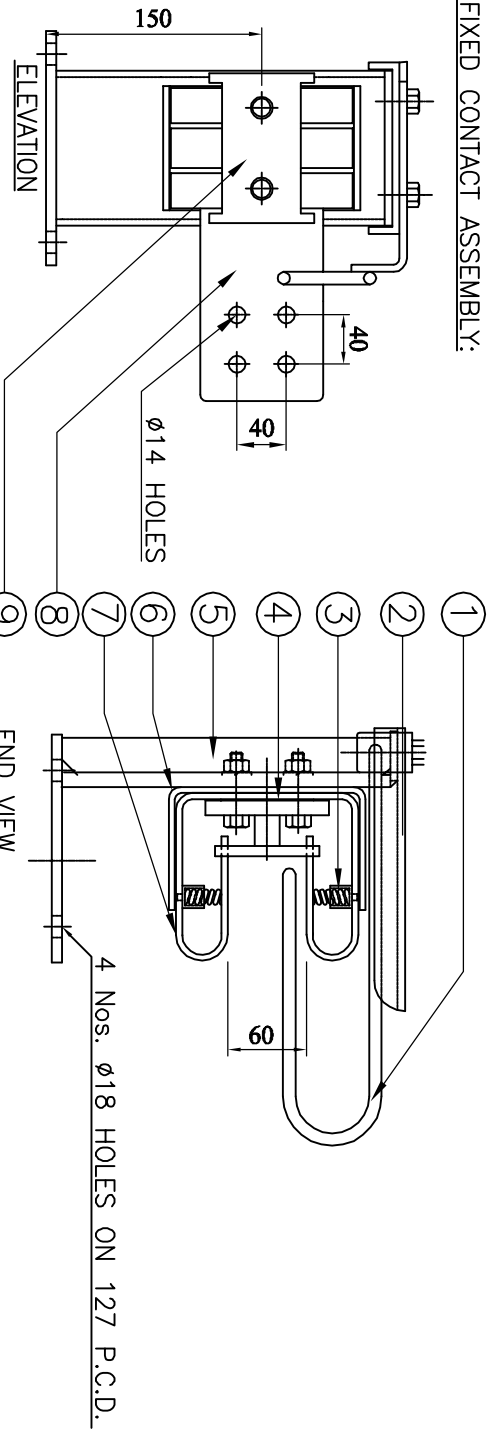

MOVING CONTACT ASSEMBLY:

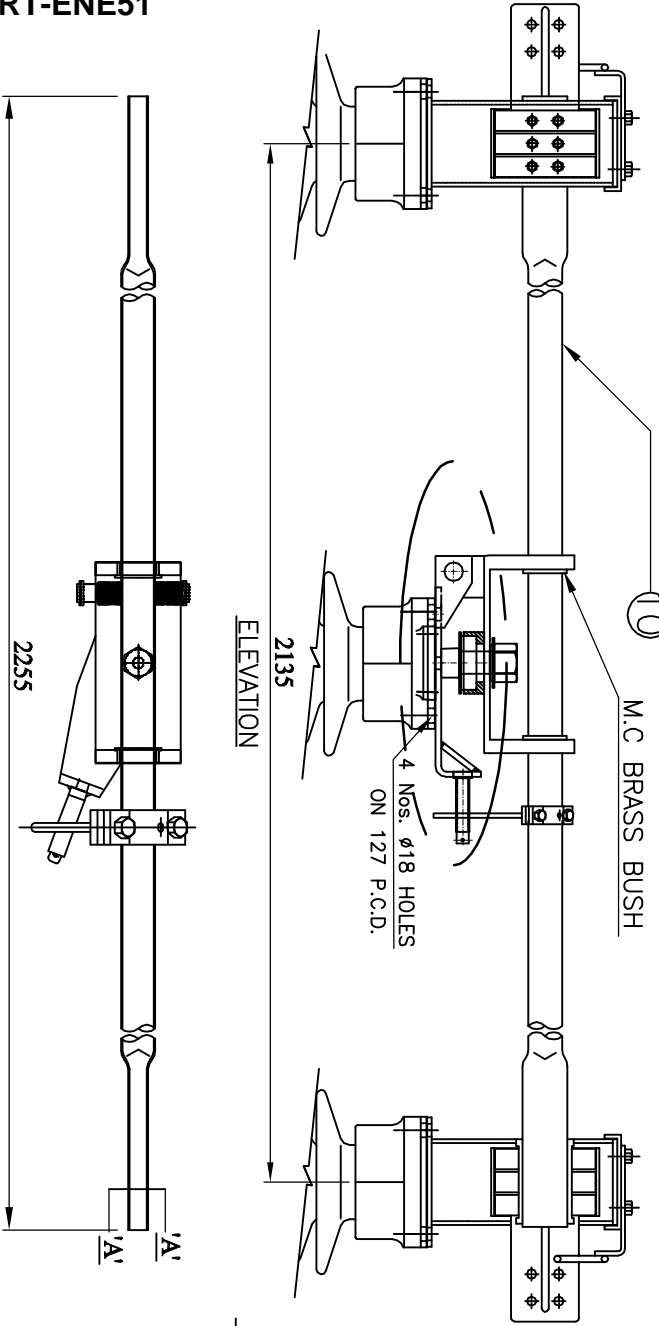

BILL OF MATERIAL PER ONE SET

SL NO.	DESCRIPTION	SIZE IN MM	MATERIAL
1.	ARCING HORNS	Ø10MM ROD	M.S HDG
2.	RAIN HOOD	1MM SHEET	M.S HDG
3.	JAW SPRINGS	Ø2mm WIRE	STAINLESS STEEL
4.	BI-METALLIC SHEET	2mm THK	ALU. + CU.
5.	FIXED CONTACT SUPPORT CHANNEL	115x30x4 mm	M.S HDG
6.	JAW SUPPORT BRACKETS	32 X 5 FLAT	M.S HDG
7.	FIXED CONTACT JAWS (3. NOS)	32 X 4 FLAT	HDEC
8.	JUMPER PAD	100 X 12 FLAT	ALUMINIUM
9.	FC SPACER	-----	ALUMINIUM
10.	MOVING CONTACT	50-ODX41-ID	HDEC

- NOTE:
1. ALL DIMENSIONS ARE IN MILLIMETER
 2. ALL FERROUS PARTS ARE HOT DIP GALVANIZED (85 MICRONS)
 3. ALL NON FERROUS CONTACT POINTS ARE SILVER PLATED (15 MICRONS)
 4. MOVING CONTACT ASSEMBLY SHOWN IS FOR TURN & TWIST ASSEMBLY

For Pavani Power Systems Pvt. Ltd.
 (T. SESHAGIRI RAO)
 Managing Director

TRANSMISSION CORPORATION OF
 ANDHRA PRADESH LTD



REVISIONS

REV	NO	DESCRIPTION
D	C	B
A		

AP TRANSCO

TRANSMISSION CORPORATION OF ANDHRA PRADESH LTD

MAIN SWITCH CONTACT ASSEMBLY (FOR 145kV, 1200A ISOLATOR)

PAVANI POWER SYSTEMS PVT.LTD.
 Plot No. 06/065/4/6, K.K. OVERSEAS SOCIETY,
 TDA, DULAPALLY, QUTHUBULLAPUR MANDAL,
 KODURU ROAD, HYDERABAD - 500100.
 MEDICAL MARKAGER DIST. TELANGANA

SCALE: 1:1

DATE: 18-05-2023

DRAWN: _____

CHECKED: _____

APPROVED: _____

SHEET: 02 OF 07

DRG. NO: PPSPT-APT-MSCA-A4-02

Drawing approval subject to valid vendor registration

Chief Engineer
 Projects

NOTE : DRAWING APPROVAL SUBJECT TO VALID TYPE TEST REPORTS, TO BE CHECKED DURING ACCEPTANCE TESTS.

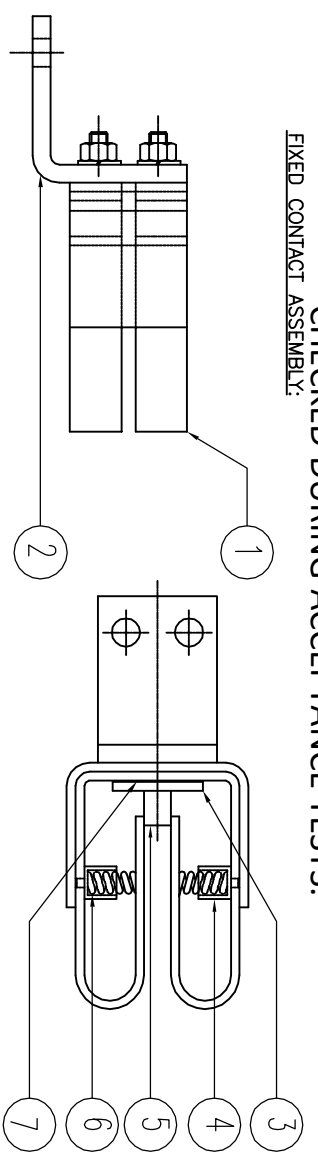

MOVING CONTACT ASSEMBLY:

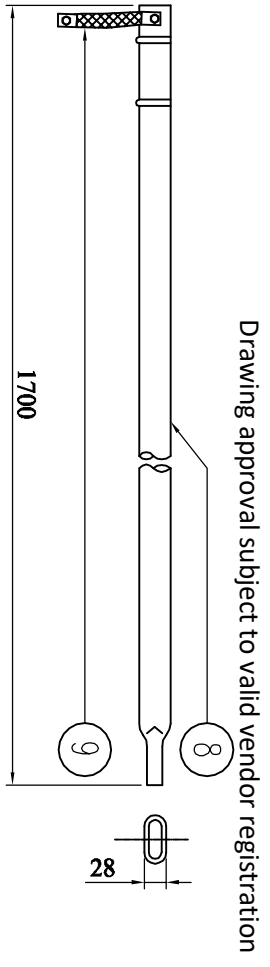

Drawing approval subject to valid vendor registration

1) Minimum 300mm plinth shall be maintained for CT/PT/CVT/Isolators in the substation during foundation works to ensure safe live to ground clearances as per IE rules.

2) Since the supply of terminal connectors is not in the scope of manufacturer as mentioned in the drawings, the EPC contractors shall be instructed to supply the same in line with CT/PT/CVT/Isolators requirement and compatibility.

FOR EPC CONTRACTS ONLY

PART LIST:

1. JAWS (32 x 4 , 2 Nos. HDEC FLAT SILVER PLATED)
2. F.C. SUPPORT PLATE (8 mm THICK M.S. HDG)
3. JUMPER PLATE (75 x 12 AL. FLAT)
4. BUSH (NYLON)
5. SPACER (ALUMINIUM)
6. SPRINGS (ø2mm, STAINLESS STEEL WIRE)
7. MOVING CONTACT ASSEMBLY (38-ODX30-ID HDEC TUBE)
8. COPPER FLEXIBLE (25X4MM, 4NOS TIN PLATED)

NOTE:

1. ALL DIMENSIONS ARE IN MILLIMETER
2. ALL FERROUS PARTS ARE HOT DIP GALVANIZED (85 MICRONS)
3. ALL NON FERROUS CONTACT POINTS ARE SILVER PLATED (15 MICRONS)
4. NECESSARY BOLT, NUTS, PLAIN & SPRING WASHERS WILL BE FITTED WITH EQUIPMENT

For Pavani Power Systems Pvt. Ltd.
 (T. SESHAGIRI RAO)
 Managing Director

AP TRANSCO
TRANSMISSION CORPORATION OF ANDHRA PRADESH LTD

Chief Engineer
 Projects

REVISIONS		TITLE:	
D	C	BARTH SWITCH CONTACT ASSEMBLY	
B	A	(FOR 145kV, ISOLATOR)	
A		SCALE: 1:1	
		DATE	18-05-2023
		DRAWN	
		CHECKED	
		APPROVED	
		SHEET	03 OF 07
		DRG. NO.	PPSP1-APT-ESCA-44-03

PAVANI POWER SYSTEMS PVT. LTD.
 Plot No. 06/065/4/6, K.K. OVERSEAS SOCIETY,
 DDA, DULAPALLY, QUTHUBULLAPUR MANDAL,
 KODURU ROAD, HYDERABAD - 500100.
 MEDICAL MANAGER DIST. TELANGANA

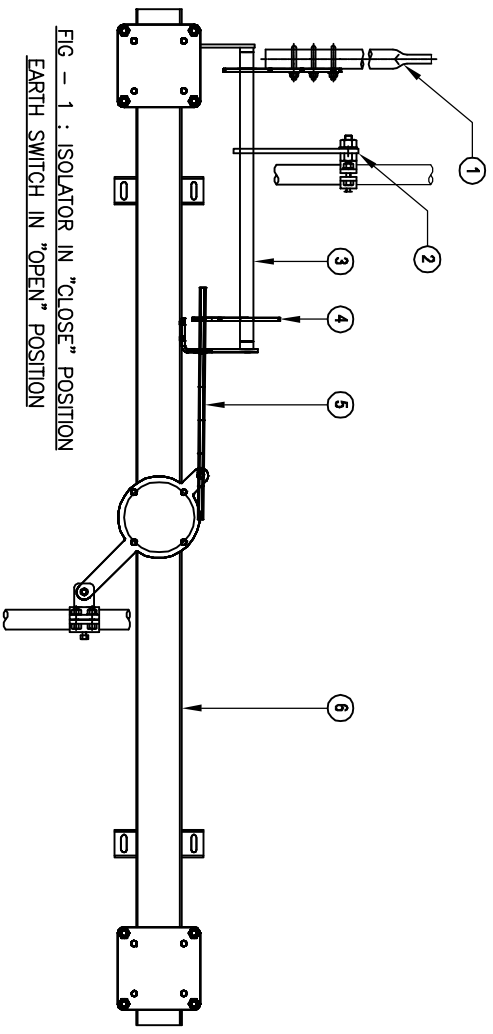

FIG - 1 : ISOLATOR IN "CLOSE" POSITION
EARTH SWITCH IN "OPEN" POSITION

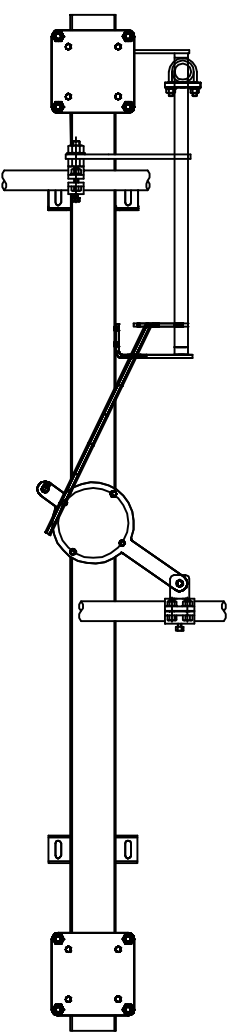

FIG - 2 : ISOLATOR IN "OPEN" POSITION
EARTH SWITCH IN "CLOSE" POSITION

NOTE : DRAWING APPROVAL SUBJECT TO VALID TYPE TEST REPORTS, TO BE CHECKED DURING ACCEPTANCE TESTS.

Drawing approval subject to valid vendor registration

CONSTRUCTION :

E.S MOVING CONTACT (1), E.S OPERATING LEVER (2) & E.S STOPPER PLATE (4) ARE CONNECTED TO THE E.S ROTATING PIPE (3). ALSO MOVES ALONG WITH THE ROTATING PIPE (3) ISOLATOR OPERATING LEVER (6) IS CONNECTED TO THE STOPPER ROD (5) WHICH IS ACT AS A MECHANICAL STOPPER.

FUNCTION :

IN FIG-1: WHEN ISOLATOR IS IN CLOSE CONDITION THEN ISOLATOR OPERATING LEVER (6) CONNECTED TO STOPPER ROD (5) MOVES THROUGH STOPPER PLATE (4) AND LOCKED WHICH WILL NOT PERMIT TO MOVE E.S ROTATING PIPE (3) EARTH SWITCH MOVING CONTACT (1) TO CLOSE POSITION.

IN FIG-2: WHEN EARTH SWITCH IS IN CLOSE CONDITION THEN ISOLATOR OPERATING LEVER (6) CONNECTED TO STOPPER ROD (5) IS LOCKED WITH STOPPER PLATE(4) WHICH WILL NOT PERMIT TO MOVE ISOLATOR OPERATING LEVER (6) TO CLOSE CLOSE POSITION.

NOTES :

1. E.S. MOVING CONTACT (38 OD X 30 ID Cu. PIPE)
2. E.S. OPERATING LEVER (50 X 10mm THIK MS FLATE HDG)
3. E.S ROTATING PIPE (25 NB MS PIPE HDG)
4. STOPPER ROD (ϕ 25mm ROD MS HDG)
5. STOPPER PATE (6mm THIK PLATE MS HDG)
7. BASE CHANNEL (145X80X5mm Thk. RECTANGLE BOX M.S HDG)

For Pavani Power Systems Pvt. Ltd.

(T. SESHAGIRI RAO)
Managing Director

Chief Engineer
Projects

		TRANSMISSION CORPORATION OF ANDHRA PRADESH LTD	
		SCALE: 1:1	
MECHANICAL INTERLOCK BETWEEN MAIN SWITCH AND EARTH SWITCH		DATE	18-05-2023
PAVANI POWER SYSTEMS PVT.LTD. Plot No. 06/066/4/6, K.K. OVERSEAS SOCIETY, 10A, DULAPALLY, QUTHUBULLAPUR MANDAL, KODURU ROAD, HYDERABAD - 500100. MEDICAL MANAGER DIST. TELANGANA		DRAWN	
REVISIONS:		CHECKED	
D	C	B	A
APPROVED		SHEET	04 OF 07
DRG. NO: PPSPT-APT-MIL-A4-04			

7459819/2023/EFMRT-ENE51

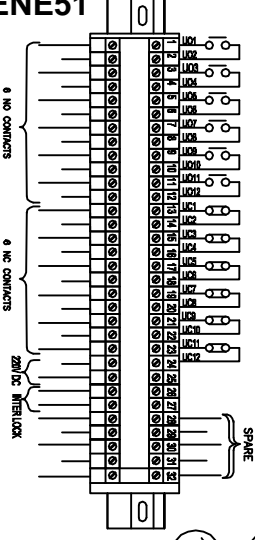
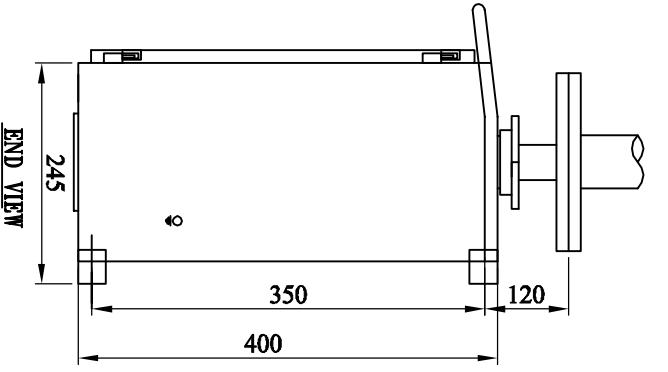

AUX. SWITCH CONTACT DETAILS FOR ISOLATOR (6 NO + 6 NC)

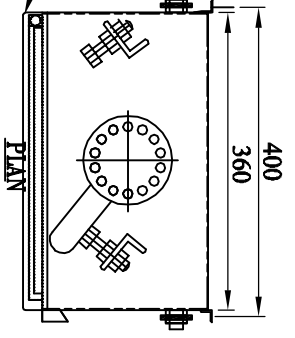
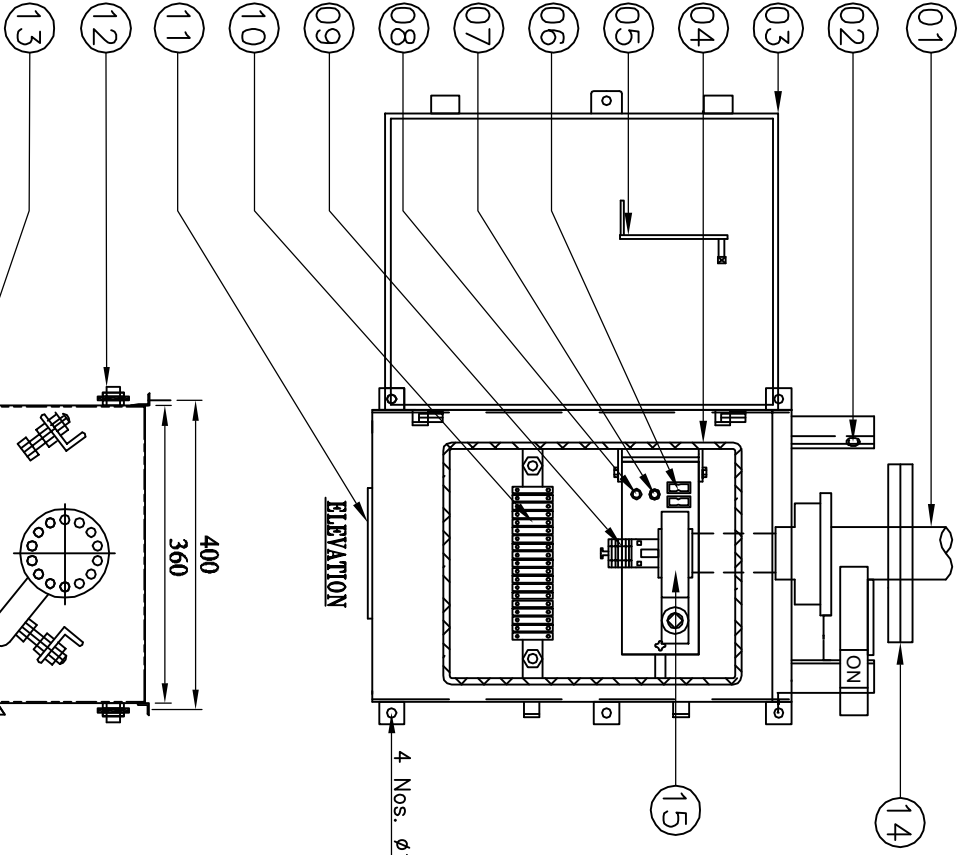

Drawing approval subject to valid vendor registration

- PART LIST:-**
1. DOWN PIPE
 2. ON & OFF STOPPER
 3. CUBICAL WITH DOOR 3mm Alu. SHEET)
 4. RUBBER GASKET (EPDM)
 5. OPERATING HANDLE
 6. FUSES (2A)
 7. INDICATION LAMP
 8. PUSH BUTTON
 9. AUXILIARY SWITCH 6NO + 6NC
 10. TERMINAL BLOCK(UBT-4 (VINMECH OR EQVT.))
 11. DETACHABLE TYPE CABLE GLANDS PLATE
 12. EARTHING TERMINAL-2 Nos.
 13. RAIN SHADE
 14. 12/14 HOLES FLANGE 8MM THK. (M.S HDG)
 15. REDUCTION GEAR BOX

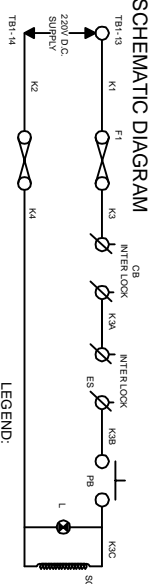

LEGEND:
 F1 F2-----FUSES (2amp Rating)
 PB-----PUSH BUTTON
 L-----INDICATION LAMP
 SC-----SOLENOID COIL

For Pavani Power Systems Pvt. Ltd.

(T. SESHAGIRI RAO)
 Managing Director

TRANSMISSION CORPORATION OF ANDHRA PRADESH LTD



MANUAL OPERATING MECHANISM BOX
 (FOR 145kV ISOLATOR)

PAVANI POWER SYSTEMS PVT.LTD.
 Plot No. 05/055/4/6, K.K. OPENERS SOCIETY,
 DDA, DULAPALLY, QUTHUBULLAPUR MANDAL,
 KOTAPALLI POST, HYDERABAD - 500100.
 MEDICAL MARKAGER DIST. TELANGANA

REVISIONS	
D	C
B	A

SCALE: 1:1	DATE: 18-05-2023
DRAWN	CHECKED
APPROVED	SHEET: 05 OF 07
DRG. NO: PPSPL-APT-RMS-44-05	

Chief Engineer
 Projects

ALL DIMENSIONS ARE IN MILLIMETERS
 CUBICLE WILL BE POWDER COATED WITH LIGHT GRAY SHADE NO:631 OF IS : 5
 DEGREE OF PROTECTION IP: 55 AS PER IS : 13947
 20% SPARE TERMINALS WILL BE PROVIDED AND SHALL BE UNIFORMLY DISRIBUTED
 TO ALL TERMINAL BLOCKS EQUALLY
 WIRING WILL BE DONE WITH 1100V.GRADE 2.5 Sq.MM CU STRANDED P.V.C.
 INSULATED CONDUCTOR
 WEIGHT OF THE BOX : 35Kg (APPROX.)
 PPSPL MAKE REDUCTION GEAR RATIO:20:1 MATERIALS EN8/STEEL

7459819/2023/EFMRT-ENE51

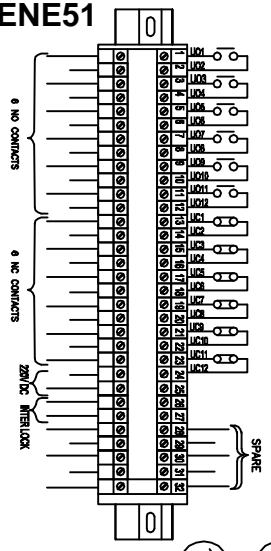
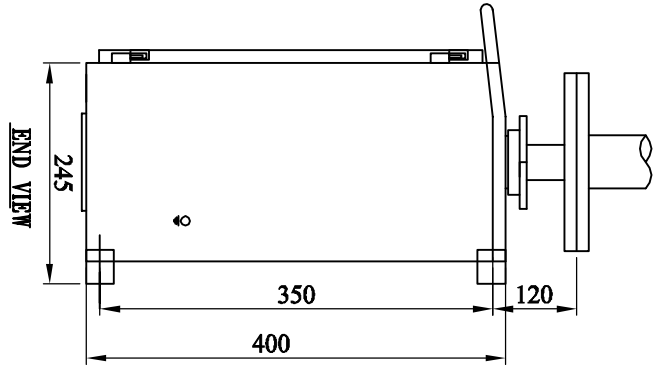

AUX. SWITCH CONTACT DETAILS FOR ISOLATOR (6 NO + 6 NC)

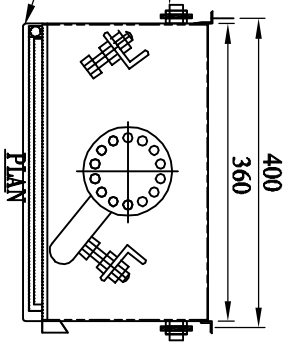
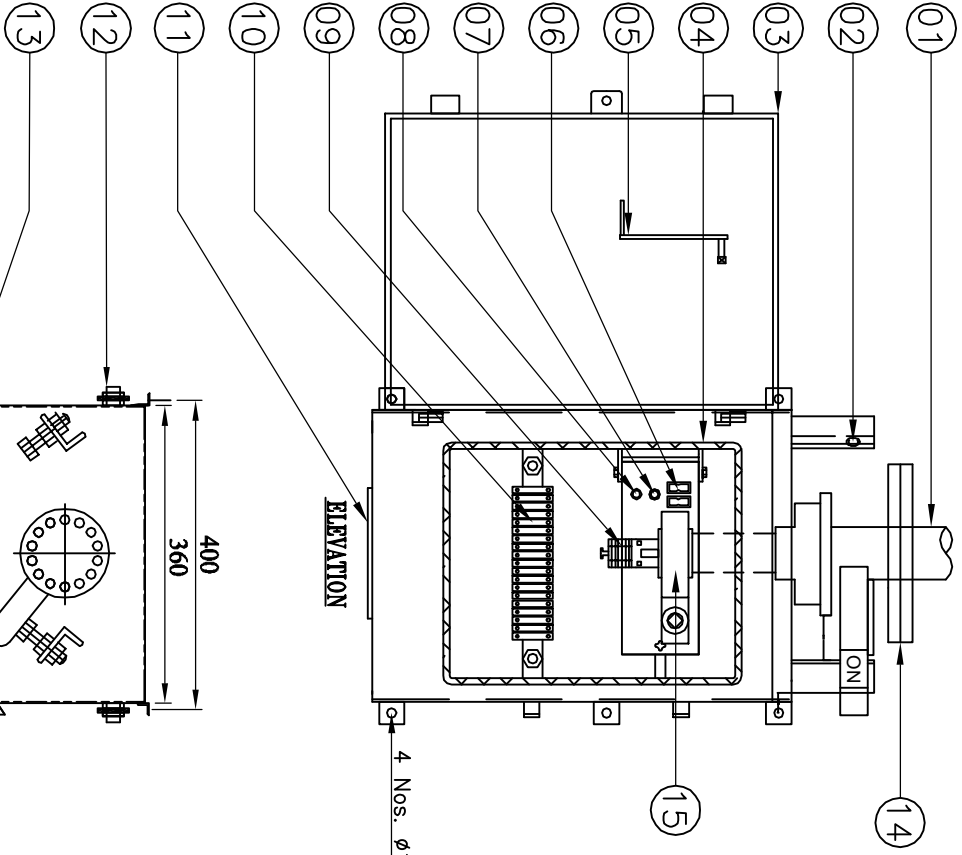

Drawing approval subject to valid vendor registration

ALL DIMENSIONS ARE IN MILLIMETERS
 CUBICLE WILL BE POWDER COATED WITH LIGHT GRAY SHADE NO:631 OF IS : 5
 DEGREE OF PROTECTION IP: 55 AS PER IS : 13947
 20% SPARE TERMINALS WILL BE PROVIDED AND SHALL BE UNIFORMLY DISRIBUTED
 TO ALL TERMINAL BLOCKS EQUALLY
 WIRING WILL BE DONE WITH 1100V.GRADE 2.5 Sq.MM CU STRANDED P.V.C.
 INSULATED CONDUCTOR

WEIGHT OF THE BOX : 35Kg (APPROX.)
 PPSPL MAKE REDUCTION GEAR RATIO:20:1 MATERIALS EN8/STEEL

Chief Engineer
 Projects

- PART LIST:-**
1. DOWN PIPE
 2. ON & OFF STOPPER
 3. CUBICAL WITH DOOR 3.mm Alu. SHEET)
 4. RUBBER GASKET (EPDM)
 5. OPERATING HANDLE
 6. FUSES (2A)
 7. INDICATION LAMP
 8. PUSH BUTTON
 9. AUXILIARY SWITCH 6NO + 6NC
 10. TERMINAL BLOCK(UBT-4 (VINMECH OR EQVT.))
 11. DETACHABLE TYPE CABLE GLANDS PLATE
 12. EARTHING TERMINAL-2 Nos.
 13. RAIN SHADE
 14. 12/14 HOLES FLANGE 8MM THK. (M.S HDG)
 15. REDUCTION GEAR BOX

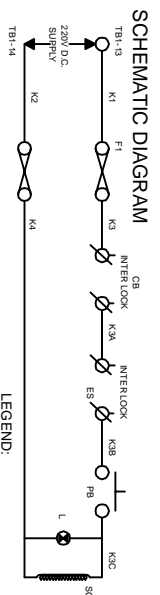

LEGEND:
 F1 F2-----FUSES (2amp Rating)
 PB-----PUSH BUTTON
 L-----INDICATION LAMP
 SC-----SOLENOID COIL

For Pavani Power Systems Pvt. Ltd.
 (T. SESHAGIRI RAO)
 Managing Director

		TRANSMISSION CORPORATION OF ANDHRA PRADESH LTD	
MANUAL OPERATING MECHANISM BOX (FOR 145kV EARTH SWITCH)			
REVISIONS D C B A		SCALE: 1:1 DATE: 18-05-2023 DRAWN:	
PAVANI POWER SYSTEMS PVT.LTD. Plot No. 06/065/4/6, K.K. OVERSEAS SOCIETY, KODURU ROAD, HYDERABAD - 500100. REGIONAL MANAGER DIST. TELANGANA		CHECKED: APPROVED: 06-07-07 SHEET: DRG.No: PPSPL-APT-RES-44-06	

NOTE : DRAWING APPROVAL SUBJECT TO VALID TYPE TEST REPORTS, TO BE CHECKED DURING ACCEPTANCE TESTS.

FOR EPC CONTRACTS ONLY

MANUFACTURED & SUPPLIED BY

PAVANI POWER SYSTEMS PVT.LTD.
 PLOT No.05/055/A/6, K.K.OWNERS SOCIETY, DULAPALLY INDUSTRIAL AREA,
 KOMMIPALLY POST, HYDERABAD-500100. MEDICAL MALAKAIGRI DIST. T.S.

ISOLATOR RATING NAME PLATE

CLIENT:	TRANSMISSION CORPORATION OF A.P LTD
CUSTOMER:	---
PO.No./DATE:	---
YEAR OF MFG.	---
TYPE	DBR
VOLTAGE (kV)	145
STC kA/SEC.	40/3
CURRENT (A)	1200
SL.No.	---
FREQUENCY (Hz)	50
I.W. VOLTAGE	650kVp
P.F.W. VOLTAGE(DRY)	275kVrms
OPERATING DRIVE	MANUAL
CONTROL VOLTAGE	220 V DC

MANUFACTURED & SUPPLIED BY

PAVANI POWER SYSTEMS PVT.LTD.
 PLOT No.05/055/A/6, K.K.OWNERS SOCIETY, DULAPALLY INDUSTRIAL AREA,
 KOMMIPALLY POST, HYDERABAD-500100. MEDICAL MALAKAIGRI DIST. T.S.

ISOLATOR RATING NAME PLATE

CLIENT:	TRANSMISSION CORPORATION OF A.P LTD
CUSTOMER:	---
PO.No./DATE:	---
YEAR OF MFG.	---
TYPE	VERTICAL
VOLTAGE (kV)	145
STC kA/SEC.	40/3
CURRENT (A)	---
SL.No.	---
FREQUENCY (Hz)	50
I.W. VOLTAGE	650kVp
P.F.W. VOLTAGE(DRY)	275kVrms
OPERATING DRIVE	MANUAL
CONTROL VOLTAGE	220 V DC

1) Minimum 300mm plinth shall be maintained for CT/PT/CVT/Isolators in the substation during foundation works to ensure safe live to ground clearances as per IE rules.

2) Since the supply of terminal connectors is not in the scope of manufacturer as mentioned in the drawings, the EPC contractors shall be instructed to supply the same in line with CT/PT/CVT/Isolators requirement and compatibility.

For Pavani Power Systems Pvt. Ltd.

(T. SESHAGIRI RAO)
 Managing Director

Drawing approval subject to valid vendor registration



Chief Engineer
 Projects



**TRANSMISSION CORPORATION OF
ANDHRA PRADESH LTD**

NAME PLATE DETAILS

(FOR 145kV, ISOLATOR AND E.S)

REVISIONS	D	C	B	A
 <p>PAVANI POWER SYSTEMS PVT.LTD. Plot No. 05/055/A/6, K.K.OWNERS SOCIETY, DDA, DULAPALLY, QUTHBULLAPUR MANDAL, KOMMIPALLY POST, HYDERABAD - 500100. MEDICAL MALAKAIGRI DIST. TELANGANA</p>				
SCALE: 1:1				
DATE	18-05-2023			
DRAWN				
CHECKED				
APPROVED				
SHEET	07 OF 07			
DRG.No:	PPSP-APT-NPD-44-07			