



## TRANSMISSION CORPORATION OF ANDHRA PRADESH LTD.

**GUARANTEED TECHNICAL PARTICULARS FOR 145kV 2000A DB  
WITHOUT EARTH SWITCH ISOLATOR**

S.No	DESCRIPTION	GUARANTEED VALUE
1	Type / Installation	"DBR' Double Break Center post rotating type" / Outdoor installation
2	Manufacturer's Name and Country of Manufacture	<b>PAVANI POWR SYSEM PVT LTD. INDIA</b>
3	Standards according to which the isolators are manufactured	IS: 9921 - Part-I to V / IEC:62271-102
4	Miximum design voltage at which the isolator can operate (kV)	145
5	Frequency (Hz)	50
6	Rated voltage (kV)	145
7	Maximum current that can be safely interrupted by the isolator Inductive (A & % PF ) Capacitive (A & % PF)	Inductive- 0.7 Amps at 0.15 p.f. Capacitive- 0.7 Amps at 0.15 p.f.
8	Continuous current rating Nominal (Amps) under site conditions	<b>2000</b>
9	Rated short time current	<b>MAIN SWITCH</b>
	i) For 3 seconds (kA rms)	<b>40KA 3.Sec.</b>
	ii) For 1 second (kA rms)	Not Applicable
	iii) Rated peak short time current (kVp)	<b>100</b>
10	Current density at the minimum cross-section of	Contact sizes indicated in Annexure - III of specification & as per the property of materials.
	a) Moving blade (Amps/ Sq.mm) Cu. Tube	2.0 Amps / Sq.mm for HDE Cu. Tube
	b) Terminal pad : Aluminum Flat	1.0 Amp/ Sq.mm for EC grade Alu. Flat
	c) Contacts : Cu.Flat	1.6 Amps/Sq.mm for HDE Cu. Flat
	d) Terminal connector : Aluminm Casting	1.0 Amps/Sq.mm for Alu. Alloy.
11	Maximum Temp. Rise of current carrying parts when carrying rated current continuously (deg.C)	Within the specified limits of IS: 9921 - PartII/ IEC-62271-102
13	<b>Insulation Levels</b>	:
	i) Impulse withstand voltage (kV peak) phase to earth across isolating distance:	650/ 750 kV peak
	ii) Switching surge withstand voltage (kV peak) phase to earth across isolating distance	Not applicable
	iii) Power frequency withstand voltage (kV rms) Phase to earth across isolating distance	275/ 315 kV rms
14	<b>Minimum clearance in air</b>	:
	i) Between poles (mm)	2700mm (For Phase spacing of 3000 mm )
	ii) Between live parts and earth (mm)	1300 mm (Equal to dry arcing distance of insulators selected)
	iii) Between live parts when switch is open	:
	a) On the same pole (mm)	2135
	b) Between adjacent poles (mm)	3000

7459873/2023/EEMRT-ENE51

PAVANI POWER SYSTEMS PVT. LTD.,



## TRANSMISSION CORPORATION OF ANDHRA PRADESH LTD.

GUARANTEED TECHNICAL PARTICULARS FOR 145KV 2000A DB  
WITHOUT EARTH SWITCH ISOLATOR

S.No	DESCRIPTION		GUARANTEED VALUE
15	<b>Rated mechanical terminal load</b>		:
	i)	Load along the terminal connector side (Kg.)	: 51
	ii)	Load across the terminal connector side (Kg.)	: 18
16	Torque required to operated the switch in Kg.m		: 35
17	<b>Design and Construction</b>		:
	i)	No. of insulators per pole	: Three
	ii)	No. of breaks per pole	: Two
	iii)	Type of closing / opening mechanism (Horizontal/Vertical break straight etc.)	: Horizontal break for isolator
	iv)	Contacts	:
	a)	Material and grade	: Hard drawn electrolytic copper flat, contact area is silver plated (15 Microns)
	b)	Cross-sectional area (mm)	: 1280 Sq.mm for 2000 Amps
	v)	<b>Moving blades</b>	:
	a)	Material and grade	: Hard drawn electrolytic copper flat, contact area is silver plated (15 Microns)
	b)	Cross-sectional area (mm)	: 1055 Sq.mm for 2000 Amps
	vi)	<b>Contact support</b>	:
	a)	Material and size of channel/block	: 4 mm thick, MS HDG
	b)	Material and size of plate	: 6 mm thick, MS HDG Plate
	vii)	Rain hood - Material grade and size	: 1mm GI Sheet
	viii)	Turn and twist mechanism	:
	a)	Material and size of clamps	: 40 x 8 mm thick, MS HDG flat.
	b)	Maerial size of springs	: 3.0 mm Stainless steel wire
	c)	Whether springs are encased	: Not encased.
	ix)	Nuts and Bolts	:
	a)	Size, material and grade in live parts	: Less than M12: Stainless steel
	b)	Size, material and grade in other parts	: M12 and above: MS HDG.
	x)	Insulator base plate / channel material and size of plate below insulators	: 225 x 75, 10mm Thk MS HDG channel
	xi)	Bearings	:
	a)	Material and size of housing	: MS HDG suitable for 40 ID taper roller/ ball bearing.
	b)	No. of bearings, location and size	: 2 Nos . Below centre rotating post insulator.

**NOTE : DRAWING APPROVAL SUBJECT TO VALID TYPE TEST REPORTS, TO BE CHECKED DURING ACCEPTANCE TESTS.**

Chief Engineer  
Projects

7459873/2023/EEMRT-ENE51

PAVANI POWER SYSTEMS PVT. LTD.,



## TRANSMISSION CORPORATION OF ANDHRA PRADESH LTD.

GUARANTEED TECHNICAL PARTICULARS FOR 145KV 2000A DB  
WITHOUT EARTH SWITCH ISOLATOR

S.No	DESCRIPTION	GUARANTEED VALUE
xii)	Tandem pipe	:
a)	Size, class and No. of pipes	: 32mm NB Class B,GI Pipe for Main switch-2Nos.
b)	Size of shackle, screw	: Suitable for 32mm NB GI Pipe
c)	No. of bearings/bush and its material and size	: Not applicable
xiii)	Type of interlock	: Electrical interlock between isolator and correspondin breaker.
xiv)	Down pipe size and class	: 50 NB Class B GI pipe
xv)	Type of universal/swivel joint	:
a)	Between bearing and down pipe	: Universal Joint (MS HDG)
b)	Between down pipe and operating mechanism	: Vernier flange
xvi)	Operating mechanism	: Manual operated mechanism for main switch
a)	Control cabinet material and thickness	: 3.mm THK Aluminum Sheet
b)	Degree of protection	: IP: 55 as per IS: 2147
c)	Type, size and No. of cable glands	: Double compression type 2Nos. 19 mm (Contractor scope of supply)
d)	Whether removable gland plate provided	: Yes, provided.
e)	Make, type, rating and quantity of motors	: Not applicable
f)	Auxiliary blocks	: 6 NO + 6 NC Contacts for main switch. 10 Amps, 2 A DC Breaking with 2A - 1 No.
g)	Terminal blocks	: UBT-4
h)	Insulated wires	: 1100 V grades, 2.5 Sq. mm PVC cable
i)	HRC Fuse	: FTC / GE / S&S or Eqvt.
j)	Space Heater	: Not applicable
k)	Interlocks	: Not applicable
xvii)	Base:	:
a)	Size of steel section used	: 145x80x5mm Rectangle box profile(M.S.HDG)
b)	Overall sie	: 145 x 80 x 2400 mm
c)	Total weight.	: 65Kgs (Approx.) one pole
Name of the firm		: For Pavani Power Systems Pvt. Ltd.
Signature of Bidder		: 
Designation & Seal		: ( T. SESHAGIRI RAO ) Managing Director
Date		: 18-05-2023
NOTE : DRAWING APPROVAL SUBJECT TO VALID TYPE TEST REPORTS, TO BE CHECKED DURING ACCEPTANCE TESTS.		

7459873/2023/FEMRT-ENE51

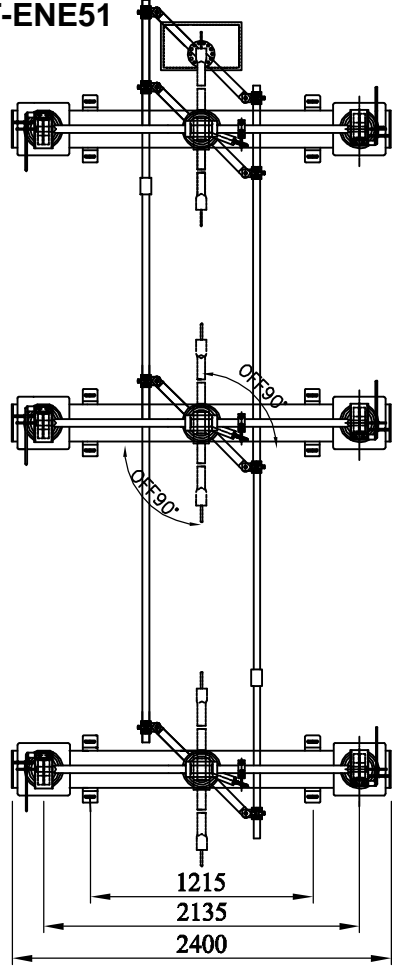
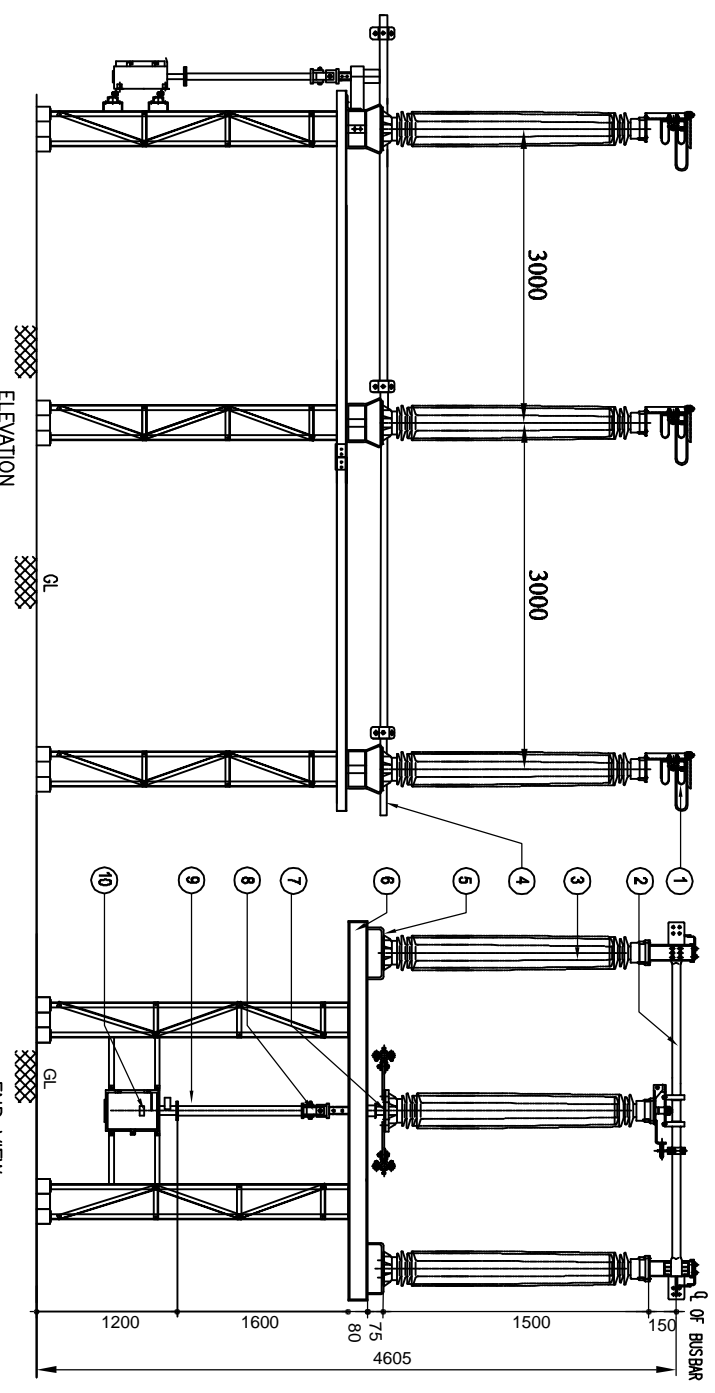

INSULATOR FIXING DETAILS

Drawing approval subject to valid vendor registration

Chief Engineer  
Projects

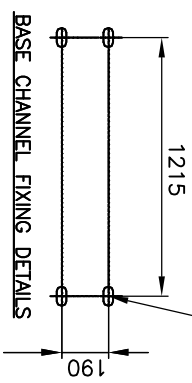
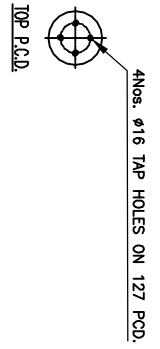
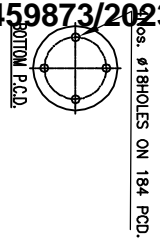

**PART LIST:**

1. FIXED CONTACT ASSEMBLY
2. MOVING CONTACT ASSEMBLY
3. INSULATOR STACK ( COSTUMER SCOPE)
4. TANDEM PIPE FOR ISOLATOR (32NB, CLASS "B" G.I PIPE)
5. ELEVATOR CHANNEL (220 X 75MM X 10MM THK M.S HDG)
6. BASE CHANNEL (145 X 80 X 5MM THK. M.S HDG)
7. ROTATING STOOL BASE WITH LEVER ARM & CLAMP (M.S HDG)
8. OPERATING PIPE CONNECTING BUSH ( M.S HDG)
9. DOWN PIPE FOR ISOLATOR (50NB CLASS" B" G.I PIPE)
10. MANUAL OPERATING MECHANISM FOR ISOLATOR

**REFERENCE DRAWINGS:**

1. FOR ISOLATOR CONTACT ASSEMBLY (2000 AMPS)
2. FOR MANUAL OPERATED MECHANISM FOR MAIN SWITCH
3. FOR NAME PLATE DETAILS

**NOTE:**

1. ALL DIMENSIONS ARE IN MILLIMETERS
2. THE INDICATED DIMENSIONS ARE SUBJECT TO THE MANUFACTURING TOLERANCE:  
 UP TO 50mm -----±3%; 51 TO 100mm ----- ±2%  
 101 TO 300mm ----- ± 1%; ABOVE 300mm -----±0.5%  
 3. SHORT TIME CURRENT RATING 40KA rms. FOR 3 Sec.  
 4. MIN. CREEPAGE DISTANCE 3625 mm(25mm/KV)  
 5. APPLICABLE STANDARD : IEC: 62271-102  
 6. ALL FERROUS PARTS ARE HOT DIP GALVANIZED (85MICRONS)

REVISIONS	
D	C
B	A

**AP TRANSCO**

**TRANSMISSION CORPORATION OF ANDHRA PRADESH LTD**

**For Pavani Power Systems Pvt. Ltd.**  
( T. SESHAGIRI RAO )  
Managing Director

**PAYANI POWER SYSTEMS PVT.LTD.**  
Plot No. 06/065/4/6, K.K. OVERSEAS SOCIETY,  
IDA, DULAPALLY, QUTHUBULLAPUR MANDAL,  
KODURU ROAD, HYDERABAD - 500100.  
NEERUCHAL WALKER DIST. TELANGANA

**TITLE:** 145KV, 2000A, TP, HDB, RT, ISOLATOR WITHOUT E.S.  
( WITH MANUAL OPERATING MECHANISM )

SCALE: 1:1	DATE: 18-05-2023
DRAWN	CHECKED
APPROVED	SHEET: 01 OF 04
DESIGN: PPSPT-APT-GAD-44-01	

FIXED CONTACT ASSEMBLY:

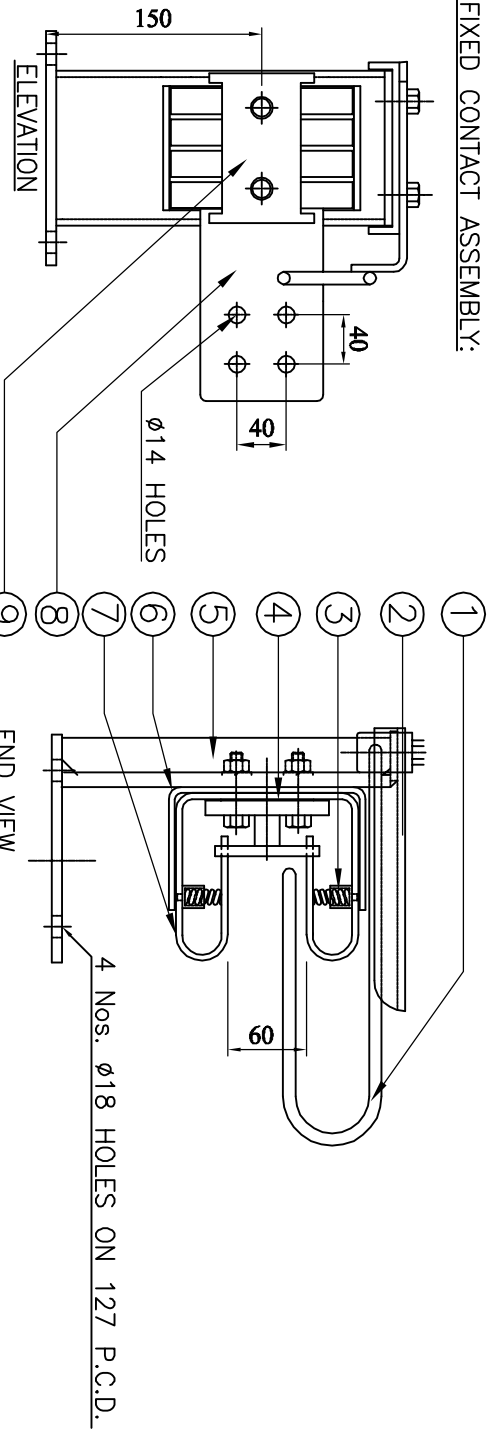

MOVING CONTACT ASSEMBLY:

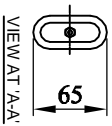
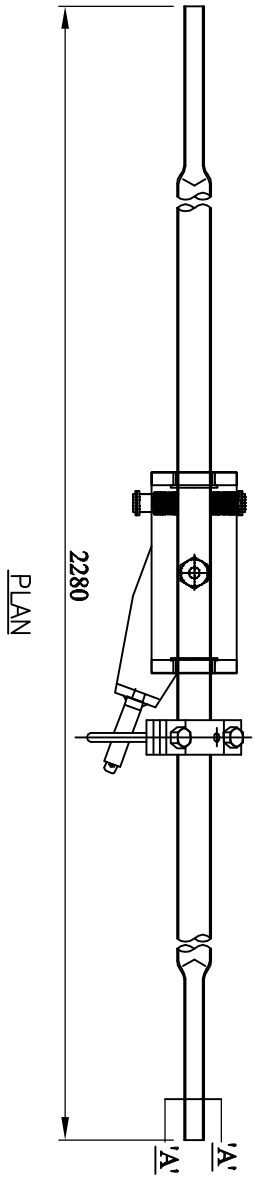
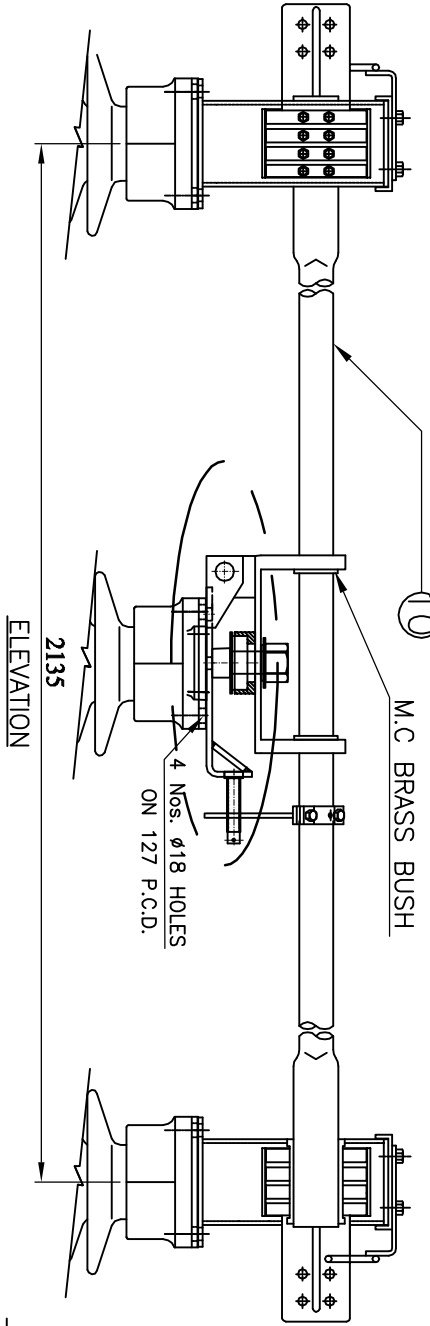

BILL OF MATERIAL PER ONE SET

Sl. NO.	DESCRIPTION	SIZE IN MM	MATERIAL
1.	ARCING HORNS	Ø10MM ROD	M.S HDG
2.	RAIN HOOD	1.MM SHEET	M.S HDG
3.	JAW SPRINGS	Ø2.mm WIRE	STAINLESS STEEL
4.	BI-METALLIC SHEET	2mm THK	ALU. + CU.
5.	FIXED CONTACT SUPPORT CHANNEL	150x30x4 mm	M.S HDG
6.	JAW SUPPORT BRACKETS	32 X 5 FLAT	M.S HDG
7.	FIXED CONTACT JAWS (4. NOS)	32 X 5 FLAT	HDEC
8.	JUMPER PAD	100 X 20 FLAT	ALUMINIUM
9.	FC SPACER	-----	ALUMINIUM
10.	MOVING CONTACT	50-ODX34-ID	HDEC

- NOTE:
1. ALL DIMENSIONS ARE IN MILLIMETER
  2. ALL FERROUS PARTS ARE HOT DIP GALVANIZED (85 MICRONS)
  3. ALL NON FERROUS CONTACT POINTS ARE SILVER PLATED (15 MICRONS)
  4. MOVING CONTACT ASSEMBLY SHOWN IS FOR TURN & TWIST ASSEMBLY

For Pavani Power Systems Pvt. Ltd.  
 (T. SESHAGIRI RAO)  
 Managing Director



TRANSMISSION CORPORATION OF  
 ANDHRA PRADESH LTD

REVISIONS		SCALE	
D	C	1:1	1:1
B	A		

TYPED: MAIN SWITCH CONTACT ASSEMBLY (FOR 145kV, 2000A ISOLATOR)		DATE	18-05-2023
PAVANI POWER SYSTEMS PVT.LTD. Plot No. 06/056/4/6, K.K. OVERSEAS SOCIETY, DDA, DULAPALLY, QUTHUBULLAPUR MANDAL, KODURU ROAD, HYDERABAD - 500100. REGIONAL MANAGER DIST. TELANGANA		DRAWN	
AP TRANSCO		CHECKED	
TRANSMISSION CORPORATION OF ANDHRA PRADESH LTD		APPROVED	
		SHEET	02 OF 04
		DRG. NO.	PPSP-APT-MSCA-A4-02

Drawing approval subject to valid vendor registration

Chief Engineer  
 Projects

7459873/2023/EFMRT-ENE51

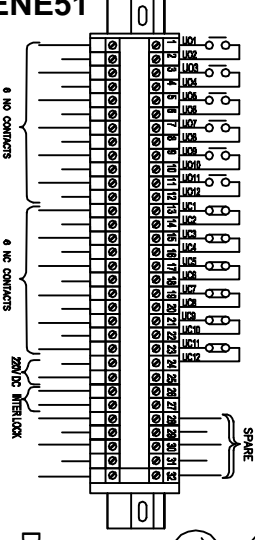
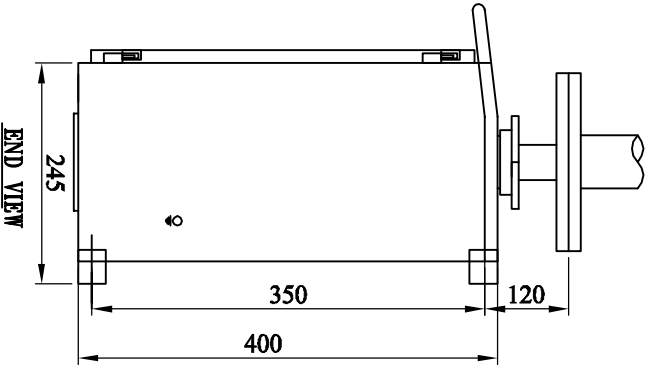

AUX. SWITCH CONTACT DETAILS FOR ISOLATOR (6 NO + 6 NC )

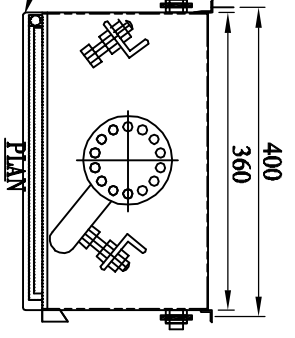
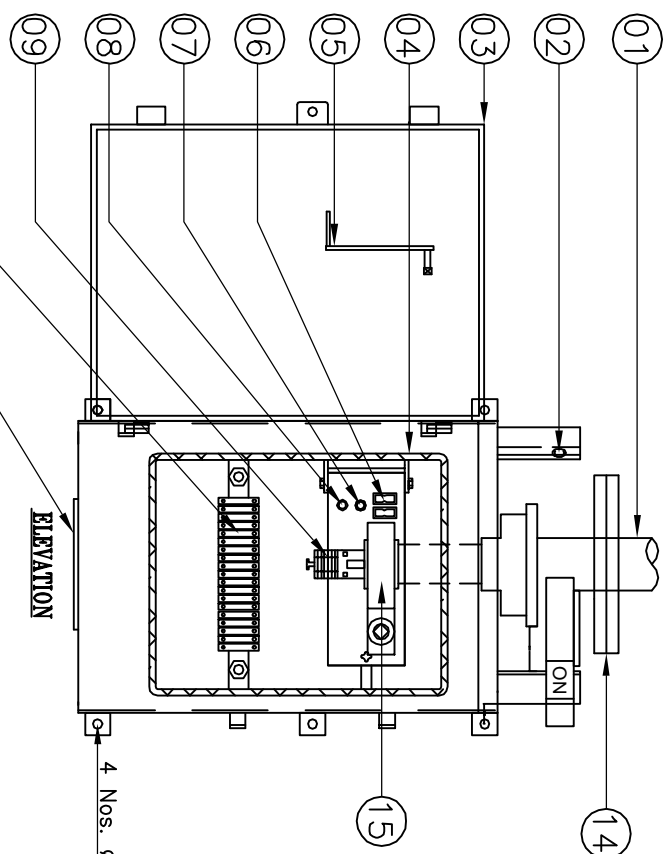

Drawing approval subject to valid vendor registration

ALL DIMENSIONS ARE IN MILLIMETERS  
 CUBICLE WILL BE POWDER COATED WITH LIGHT GRAY SHADE NO:631 OF IS : 5  
 DEGREE OF PROTECTION IP: 55 AS PER IS :13947  
 20% SPARE TERMINALS WILL BE PROVIDED AND SHALL BE UNIFORMLY DISRIBUTED  
 TO ALL TERMINAL BLOCKS EQUALLY  
 WIRING WILL BE DONE WITH 1100V.GRADE 2.5 Sq.MM CU STRANDED P.V.C.  
 INSULATED CONDUCTOR  
 WEIGHT OF THE BOX : 35Kg (APPROX.)  
 PPSPL MAKE REDUCTION GEAR RATIO:20:1 MATERIALS EN8/STEEL

Chief Engineer  
 Projects

PART LIST:-

1. DOWN PIPE
2. ON & OFF STOPPER
3. CUBICAL WITH DOOR 3.mm Alu. SHEET)
4. RUBBER GASKET (EPDM)
5. OPERATING HANDLE
6. FUSES (2A)
7. INDICATION LAMP
8. PUSH BUTTON
9. AUXILIARY SWITCH 6NO + 6NC
10. TERMINAL BLOCK(UBT-4 (VINMECH OR EQVT.))
11. DETACHABLE TYPE CABLE GLANDS PLATE
12. EARTHING TERMINAL-2 Nos.
13. RAIN SHADE
14. 12/14 HOLES FLANGE 8MM THK. (M.S HDG)
15. REDUCTION GEAR BOX

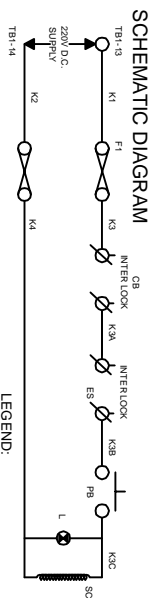

LEGEND:  
 F1 F2-----FUSES (2amp Rating)  
 PB-----PUSH BUTTON  
 L-----INDICATION LAMP  
 SC-----SOLENOID COIL

For Pavani Power Systems Pvt. Ltd.

( T. SESHAGIRI RAO )  
 Managing Director



TRANSMISSION CORPORATION OF  
 ANDHRA PRADESH LTD

REVISIONS		SCALE: 1:1	
D	C	18-05-2023	
B	A	DRAWN	
A		CHECKED	
		APPROVED	
		SHEET	03 OF 04
		DESIGN	PPSP-APT-RMS-44-03

MANUAL OPERATING MECHANISM BOX  
 ( FOR 145kV ISOLATOR )  
 PAVANI POWER SYSTEMS PVT.LTD.  
 Plot No. 05/055/4/6, K.K. OVERSEAS SOCIETY,  
 DDA, DULAPALLY, QUTHUBULLAPUR MANDAL,  
 KOMPAKU POST, HYDERABAD - 500100.  
 MEDICAL MARKAGER DIST. TELANGANA

NOTE : DRAWING APPROVAL SUBJECT TO VALID TYPE TEST REPORTS, TO BE CHECKED DURING ACCEPTANCE TESTS.

FOR EPC CONTRACTS ONLY

Drawing approval subject to valid vendor registration

		MANUFACTURED & SUPPLIED BY <b>PAVANI POWER SYSTEMS PVT.LTD.</b> PLOT No.05/055/A/6, K.K.OWNERS SOCIETY, DULAPALLY INDUSTRIAL AREA, KOMMIPALLY POST, HYDERABAD-500100. MEDCHAL WALKAIGIRI DIST. T.S.	
ISOLATOR RATING NAME PLATE			
CLIENT:	TRANSMISSION CORPORATION OF A.P LTD		
CUSTOMER:	-----		
PO.No/DATE:	-----		
YEAR OF MFG.	-----	SL.No.	-----
TYPE	DBR	FREQUENCY (Hz)	50
VOLTAGE (kV)	145	I.W. VOLTAGE	650Kvp
STC kA/SEC.	40/3	P.F.W. VOLAGE(DRY)	275KVrms
CURRENT (A)	2000	OPERATING DRIVE	MANUAL
		CONTROL VOLTAGE	220 V DC

- 1) Minimum 300mm plinth shall be maintained for CT/PT/CVT/Isolators in the substation during foundation works to ensure safe live to ground clearances as per IE rules.
- 2) Since the supply of terminal connectors is not in the scope of manufacturer as mentioned in the drawings, the EPC contractors shall be instructed to supply the same in line with CT/PT/CVT/Isolators requirement and compatibility.

Chief Engineer  
Projects

For Pavani Power Systems Pvt. Ltd.  
( T. SESHAGIRI RAO )  
Managing Director

		TRANSMISSION CORPORATION OF <b>ANDHRA PRADESH LTD</b>	
AP TRANSCO			
NAME PLATE DETAILS ( FOR 145kV ISOLATOR )		SCALE: 1:1	DATE: 18-05-2023
PAVANI POWER SYSTEMS PVT.LTD. Plot No. 05/055/A/6, K.K.OWNERS SOCIETY, DDA, DULAPALLY, QUTHUBULLAPUR MANDAL, KOMMIPALLY POST, HYDERABAD - 500100. MEDCHAL WALKAIGIRI DIST. TELANGANA		DRAWN:	CHECKED:
REVISIONS D C B A		APPROVED:	SHEET: 04 OF 04
		DRG.No:	PPSPT-APT-NPD-44-04