

145 KV

Drawing approval subject to valid vendor registration

Item [REDACTED] CT

Ratio: 300-200/1-1-1A (3 C)

Creepage: 25mm/kV

Customer: APTransco, Andhra Pradesh

**List of Standard Drawings/Documents:**

Sl. No.	Description	Drawing/ Doc No.
1	General Arrangement	APTR-02.25.145J1
2	Rating Plate	APTR-02.25.145J2_REV No.01
3	Terminal Box GA	APTR-02.25.145J3_REV No.01
4	Sectional View	APTR-02.25.145J4_REV No.01
5	GTP	--

Variation of Tan Delta Value from 10KV  $\mu\text{m}/\sqrt{3}$  shall be not exceed 15%.

1. Minimum 300mm plinth shall be maintained for CT/PT/CVT/ Isolators/IVT in the substation during foundation works to ensure safe live to ground clearance as per IE rules.
2. Since the supply of terminal connectors is not in the scope of manufacturers as mentioned in the drawings. The EPC contractors shall be instructed to supply the same in line with CT/PT/CVT/Isolator /IVTs requirement and capatibility.

CHIEF ENGINEER/PROJECTS  
APTRANSCO/Vs/Vijayawada

NOTE:-1. Drawings approval subject to valid type test reports, to be checked during acceptance tests.  
2. For EPC contractors only.

IF IN DOUBT ASK

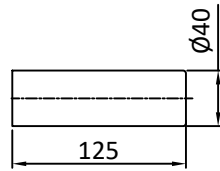
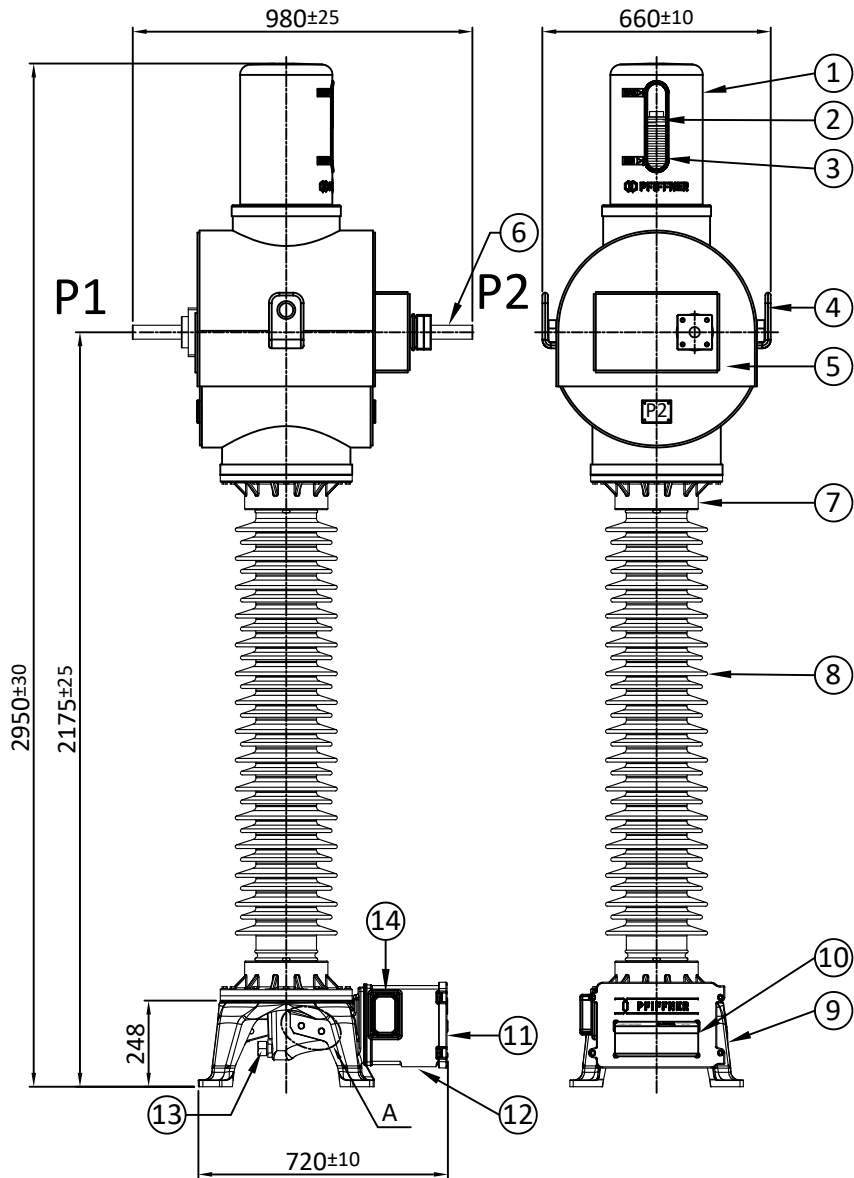

TERMINAL DETAIL

2Nos. of Ø15 Hole for Earthing Diagonally opposite

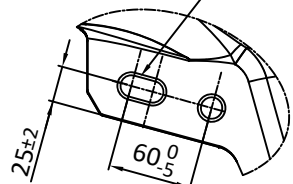

Detail 'A'

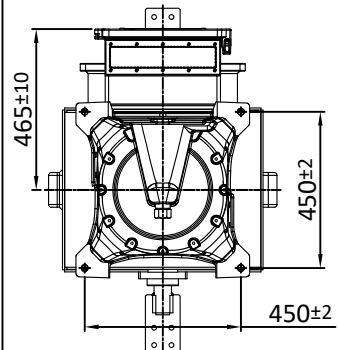

CT MOUNTING DETAIL

NO.	QTY.	DESCRIPTION	MATERIAL
01	01	BELLOWS COVER	ALUMINIUM
02	01	BELLOWS	STAINLESS STEEL
03	01	BELLOW LEVEL INDICATOR	POLYCARBONATE
04	02	LIFTING LUG	ALUMINIUM
05	01	HOUSING	ALUMINIUM
06	02	PRIMARY TERMINAL	ALUMINIUM
07	02	INSULATOR FLANGE	ALUMINIUM
08	01	INSULATOR	PORCELAIN
09	01	BASE	ALUMINIUM
10	01	RATING PLATE	ALUMINIUM
11	01	TERMINAL BOX	ALUMINIUM
12	01	GLAND PLATE	ALUMINIUM
13	01	OIL SAMPLING VALVE	STEEL GALVANISED
14	01	TAN DELTA MEASUREMENT TERMINAL	BRASS

TOTAL WEIGHT : 470 kg ±10%  
TOTAL OIL WEIGHT : 120 kg ±10%  
CREEPAGE DISTANCE : ≥3625 mm

CHIEF ENGINEER/PROJECTS  
APTRANSCO/VS/Vijayawada

Customer : TRANSMISSION CORPORATION OF ANDRA PRADESH LTD.

Variation of Tan Delta Value from 10KV um/sqrt 3 shall be not exceed 15%.

This document must not be copied without our written permission and the content and nor be used for any unauthorised purpose. Contravention will be prosecuted. © PFIFFNER

REV.NO.	DESCRIPTION	APPV'D	REV. DATE
GEN. TOL : NA	MATERIAL : NA		
WEIGHT : NA			
NAME	SIGN	DATE	SPEC : NA
DRAWN	M.D.	08.03.2023	FINISH : NA
CHK'D	M.C.	08.03.2023	
APPV'D	R.P.	08.03.2023	
<b>PFIFFNER</b> Instrument Transformers Pvt.Ltd. NASHIK, INDIA			TITLE : GENERAL ARRANGEMENT 145KV CT DWG NO. APTR-02.25.145J1 SHEET 1 OF 1   REV. NO. : 00

NOTE:-1. Drawings approval subject to valid type test reports,

to be checked during acceptance tests.

2. For EPC contractors only.

IF IN DOUBT ASK

**PFIFFNER** Instrument Transformers Pvt.Ltd. NASHIK, INDIA **CURRENT TRANSFORMER**

CUSTOMER : TRANSMISSION CORPORATION OF ANDRA PRADESH LTD. PO No. : -----

YEAR	----	SPECIFICATION	IS 16227, IEC 61869	H.S.V.	145kv	SERIAL NO.	-----
TYPE	JOF 145 W	STC.	31.5 kA for 1S	INSULATION LEVEL	275 kv/650 kvp	RATED PRIMARY CURRENT	300 A
FREQUENCY	50 Hz	Idyn	78.75 kAp	TOTAL CREEPAGE DISTANCE	≥ 3625mm	RATED CONT. THERMAL CURRENT	360 A
CORE NO.	1		2		3		
RATIO	200/1	300/1	200/1	300/1	200/1	300/1	
PRI. TERMINAL	P1-P2	P1-P2	P1-P2	P1-P2	P1-P2	P1-P2	
SEC. TERMINAL	1S1-1S2	1S1-1S3	2S1-2S2	2S1-2S3	3S1-3S2 (SHORT 3S2-A)	3S1-3S3 (SHORT 3S3-A)	
VA	20	20	--	--	20	20	
CLASS	5P	5P	PX	PX	0.2S	0.2S	
ISF/ALF	20	20	--	--	≤5	≤5	
Vk (V) min.	--	--	≥40I(Rct+10)		--	--	
max Iexc at Vk (mA)	--	--	≤ 30mA		--	--	
Rct (Ω)	--	--	--		--	--	
Total weight	470 ±10% kg		Oil weight		120 ±10% kg		

Dimensions: 234±0.2, 240, 94±0.2, 100, R2, Ø1.7 (04 Nos.)

CHIEF ENGINEER/PROJECTS  
APTRANSCO/VS/Vijayawada

Variation of Tan Delta Value from 10KV um/sqrt 3 shall be not exceed 15%.

**PFIFFNER** Instrument Transformers Pvt.Ltd. NASHIK, INDIA **CURRENT TRANSFORMER**

SERIAL NO. -----  
YEAR -----

Dimensions: 140±0.2, 148, 98±0.2, 105, R2, Ø1.7 (04 Nos.)

CAUTION : - Short all sec. terminals when not in use or before disconnecting burdens. Also check bellows position.  
- Capacitance & tan delta terminal 'T<sub>6</sub>' shall always be connected to earth & disconnect only for measurement.

Drawing approval subject to valid vendor registration

Customer : TRANSMISSION CORPORATION OF ANDRA PRADESH LTD.

01	AS PER CUSTOMER COMMENTS.			CHM	18.04.2023
REV.NO.	DESCRIPTION			APPV'D	REV. DATE
GEN. TOL. : NA		MATERIAL : 1mm thick Aluminium metal photo			
WEIGHT : NA		SPEC : NA			
DRAWN	M.D.	08.03.2023	ALL DIMENSION ARE IN MM. UNLESS OTHRWISE SPECIFIED.		
CHK'D	M.C.	08.03.2023	SCALE : N.T.S.		
APPV'D	R.P.	08.03.2023	SHEET SIZE : A3		
<b>PFIFFNER</b> Instrument Transformers Pvt.Ltd. NASHIK, INDIA			TITLE : RATING PLATE 145 kv CT		SHEET NO. APTR-02.25.145J2
			SHEET 1 OF 1		REV. NO. : 01

This document must not be copied without our written permission and the content and nor be used for any unauthorised purpose. Contravention will be prosecuted. **PFIFFNER**

NOTE:-1. Drawings approval subject to valid type test reports,

to be checked during acceptance tests.

2 For EPC contractors only.

IF IN DOUBT ASK

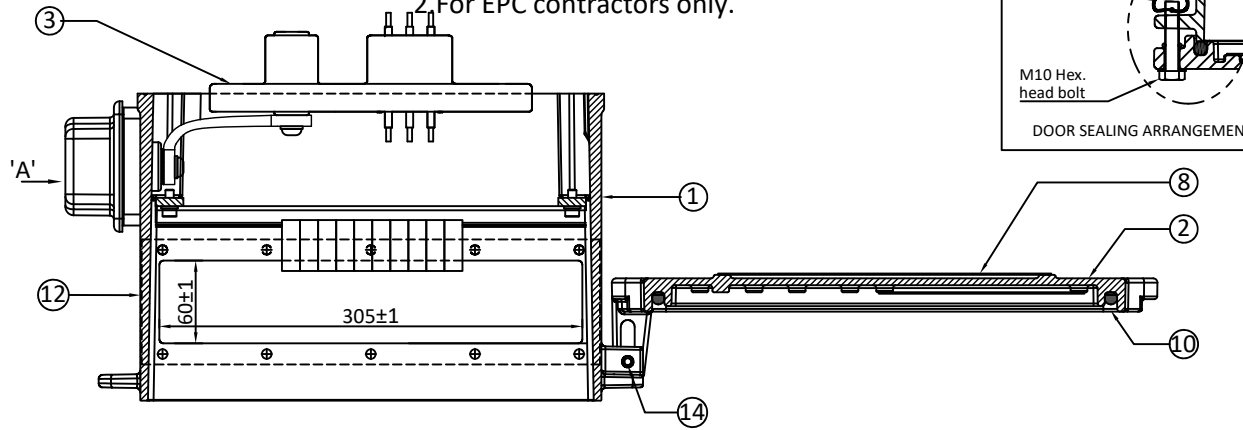

SR.NO.	DESCRIPTION	QTY.	MATERIAL
1	TERMINAL BOX	1	ALUMINIUM
2	TERMINAL BOX DOOR	1	ALUMINIUM
3	SECONDARY LEAD OUT	1	EPOXY
4	STUD TYPE TERMINAL BLOCK (KBT M4 )	10+2 SPARE	MAKE - ELMEX
5	TERMINAL CARRIER RAIL	2	STEEL
6	GLAND PLATE	1	ALUMINIUM
7	GLAND PLATE GASKET	1	NEOPRENE RUBBER
8	RATING PLATE	1	ALUMINIUM
9	SCHEMATIC DIAGRAM PLATE	1	ALUMINIUM
10	DOOR GASKET	1	EPDM RUBBER
11	DOOR EARTHING CABLE	1	PVC INSULATED COPPER CABLE
12	WARNING STICKER	1	ALUMINIUM
13	TAN DELTA (T <sub>δ</sub> ) MEASUREMENT TERMINAL	1	BRASS
14	HINGES	2	S.S. TENSION PIN
15	TAN DELTA EARTH LINK	1	COPPER (NICKEL PLATED)

DEGREE OF PROTECTION : IP 55

Variation of Tan Delta Value from 10KV um/sqrt 3 shall be not exceed 15%.

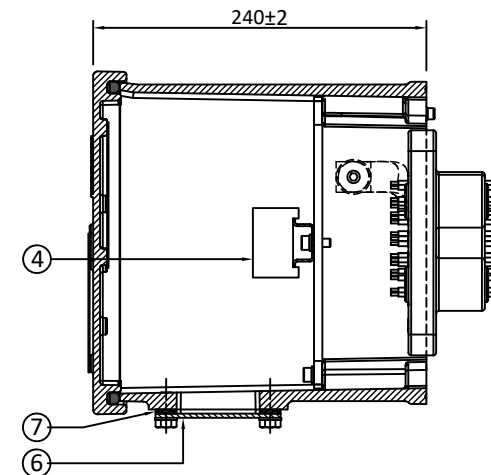
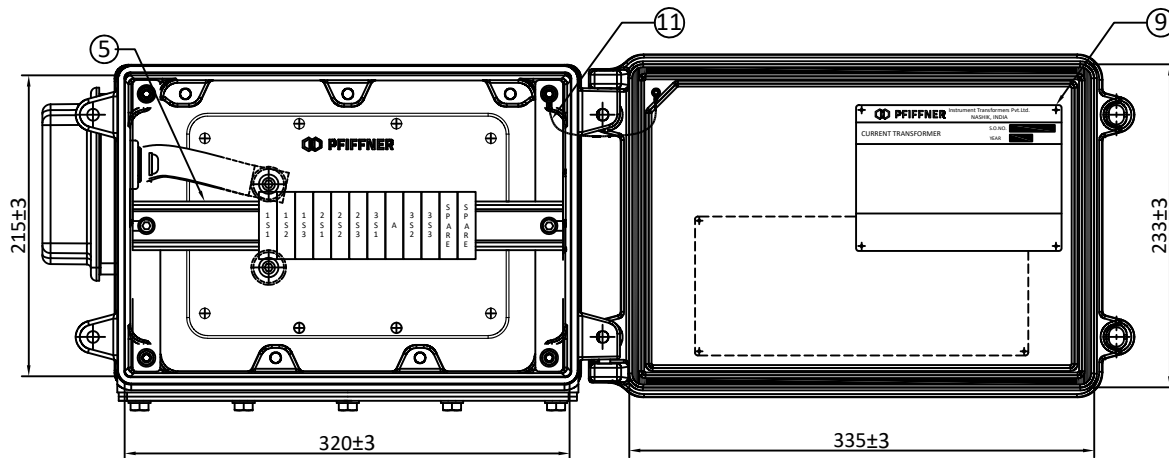

Drawing approval subject to valid vendor registration

Customer : TRANSMISSION CORPORATION OF ANDRA PRADESH LTD.

This document must not be copied without our written permission and the content and nor be used for any unauthorised purpose. Contravention will be prosecuted. PFIFFNER

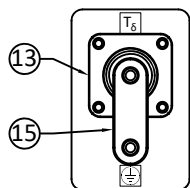

Detail 'A'

**WARNING**  
"T<sub>δ</sub>" TERMINAL - DO NOT OPEN WHEN IN SERVICE

Item : 12

CHIEF ENGINEER/PROJECTS  
APTRANSCO/VS/Vijayawada

01	AS PER CUSTOMER COMMENTS.			CHM	18.04.2023
REV.NO.	DESCRIPTION			APPV'D	REV. DATE
GEN. TOL : NA		MATERIAL : NA			
WEIGHT : NA		SPEC : NA			
DRAWN	M.D.	08.03.2023	FINISH : NA	ALL DIMENSION ARE IN MM. UNLESS OTHRWISE SPECIFIED.	
CHK'D	M.C.	08.03.2023		SCALE : N.T.S.	
APPV'D	R.P.	08.03.2023		SHEET SIZE : A3	
 Instrument Transformers Pvt.Ltd. NASHIK, INDIA			TITLE : TERMINAL BOX GA 145KV CT	DWG NO. APTR-02.25.145J3	
				SHEET 1 OF 1	REV. NO. : 01

NOTE:-1. Drawings approval subject to valid type test reports, to be checked during acceptance tests.  
2. For EPC contractors only.

IF IN DOUBT ASK

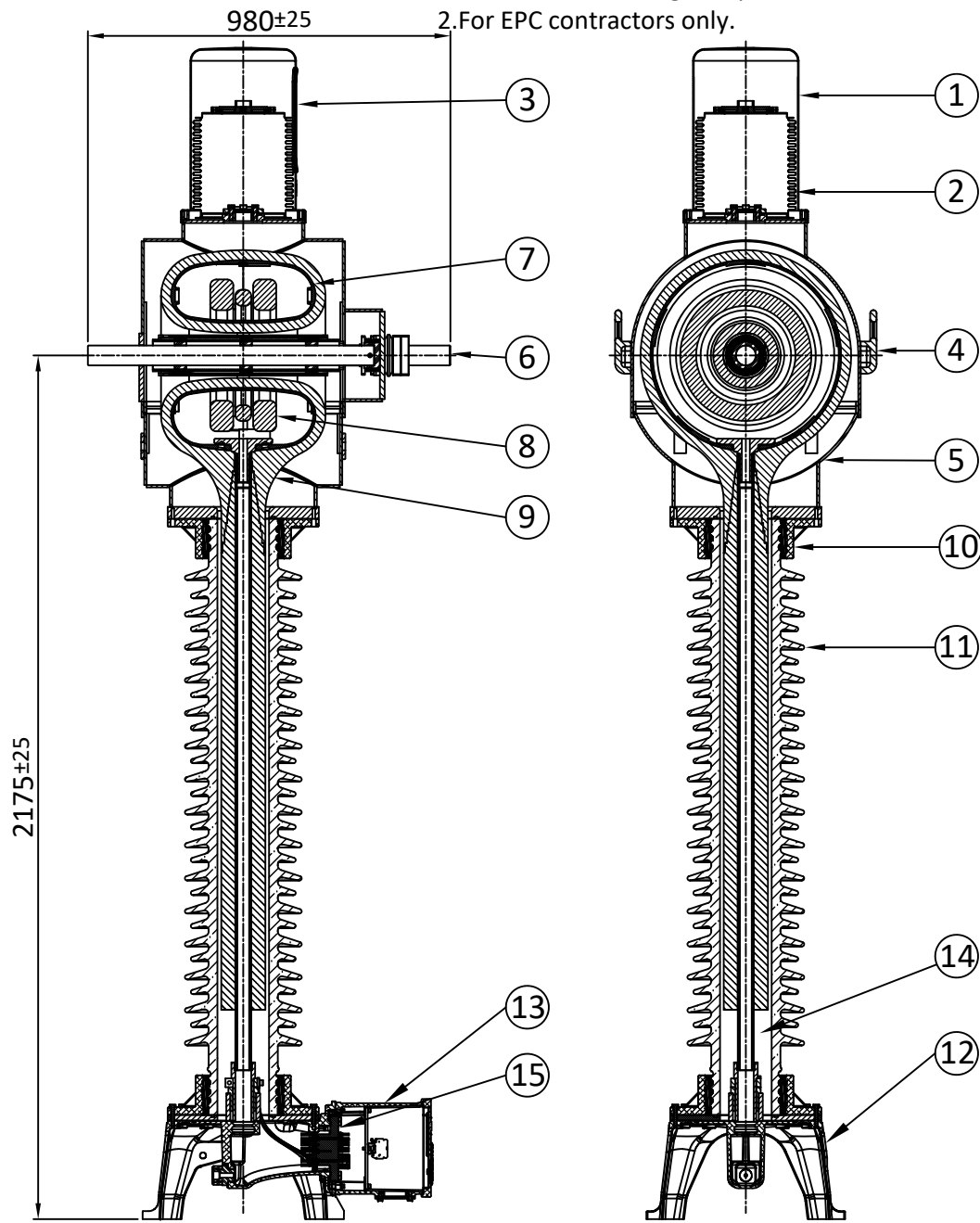

NO.	QTY.	DESCRIPTION	MATERIAL
01	01	BELLOWS COVER	ALUMINIUM
02	01	BELLOWS	STAINLESS STEEL
03	01	BELLOW LEVEL INDICATOR	POLYCARBONATE
04	02	LIFTING LUG	ALUMINIUM
05	01	HOUSING	ALUMINIUM
06	02	PRIMARY TERMINAL	ALUMINIUM
07	01	CORE BOX	ALUMINIUM
08	01	SECONDARY CORES	CRGO & NANO
09	01	ACTIVE PART	OIL IMPREGNATED PAPER
10	02	INSULATOR FLANGE	ALUMINIUM
11	01	INSULATOR	PORCELAIN
12	01	BASE	ALUMINIUM
13	01	TERMINAL BOX	ALUMINIUM
14	--	INSULATING OIL	EHV Grade - MINERAL OIL
15	01	SECONDARY LEADOUT	EPOXY

Notes:

- Insulating oil shall be EHV Grade as per IS 335, IEC 296
- Core : CRGO Si-Fe/ Equivalent high permeability material, MU- Metal, NANO - crystalline
- Secondary winding - Enamelled copper

Drawing approval subject to valid vendor registration

CHIEF ENGINEER/PROJECTS  
APTRANSCO/VS/Vijayawada

Customer : TRANSMISSION CORPORATION OF ANDRA PRADESH LTD.

This document must not be copied without our written permission and the content and nor be used for any unauthorised purpose. Contravention will be prosecuted. © PFIFFNER

Variation of Tan Delta Value from 10KV um/sqrt 3 shall be not exceed 15%.

01	AS PER CUSTOMER COMMENTS.			CHM	18.04.2023
REV.NO.	DESCRIPTION			APPV'D	REV. DATE
GEN. TOL. : NA		MATERIAL : NA			
WEIGHT : NA		SPEC : NA			
DRAWN	M.D.	08.03.2023	FINISH : NA	ALL DIMENSION ARE IN MM. UNLESS OTHRWISE SPECIFIED.	
CHK'D	M.C.	08.03.2023	SCALE : N.T.S.	SHEET SIZE : A3	
APPV'D	R.P.	08.03.2023	TITLE :	DRG NO.	
<b>PFIFFNER</b> Instrument Transformers Pvt.Ltd. NASHIK, INDIA			SECTIONAL VIEW 145KV CT	APTR-02.25.145J4	
				SHEET 1 OF 1	REV. NO. : 01

Variation of Tan Delta Value from 10KV um/sqrt 3 shall be not exceed 15%.

**Annexure-A**  
**GUARANTEED TECHNICAL PARTICULARS FOR CURRENT TRANSFORMERS**

JOF 145 W OUTDOOR CURRENT TRANSFORMERS  
(145kV 300A CT, 3 Core 25mm Creepage)

Sl.No	Particulars	Description
1	Type of tank/Installation Dead/Live Tank Type	Live Tank, Single Phase, Oil Filled, Outdoor Type
2	Type of mounting	Pedestal Mounting
3	Manufacturer's Name and address and Country of Manufacture	PFIFNER Instrument Transformers Pvt Limited, Gat No. 176, 178/2, Sarul, Nashik 422010, Maharashtra, INDIA
4	Whether Conforming to IEC 61869 Standard	Yes, IEC 61869-1&2
5 a)	Primary and Secondary winding made out of	Primary - Aluminium alloy of C/S area 1250mm <sup>2</sup> Secondary- Copper alloy f C/S area 1.168mm <sup>2</sup>
b)	Material used for providing Primary Terminals	Aluminium
c)	Material used for providing secondary Terminals	Copper Alloy
d)	Whether Primary is Rigid Bar type in case of live tank	Yes, Rigid Bar type
6	Rated primary voltage (kV rms)	132 kV
7	Rated highest voltage (kV rms)	145 kV
8	Rated frequency (Hz)	50 Hz
9	Rated primary current (A)	300A
10	Rated secondary current (A)	1A
11	Ratio taps (on secondary side only)	On Secondary Only
12	Type of insulation	Class A
13	Seismic acceleration (g)	0.3g
14	RIV at 1.1 x Rated voltage (mv)	< 500 Micro Volts
15	Tank material and Tank coating	Aluminium Tank with Natural Finish
16	Porcelain housing and it make (Single piece only)	IEC/Modern/Ravikiran
17	Sealing (Nitrogen gas cushion/Metal Bellow)	Stainless Steel Bellows
18	Instrument security factor	≤ 5 (For Metering core )
19	Tan Delta	< 0.5%
20	Partial Discharge Level	< 5pC at 1.2 x Um /√3, < 10pC at Um (where Um is highest system voltage)
21	Rated short time withstand current for 1 sec. duration (kA rms)	31.5 kA
22	Rated dynamic withstand current (kAp)	78.75

Drawing approval subject to valid vendor registration

Sl.No	Particulars	Description		
23	Rated continuous thermal current (pu) where pu = rated current	Rated Extended Primary Current 120%		
24	1.2/50 micro second impulse withstand voltage (kVp)	650 kVp		
25	One minute power frequency withstand voltage (kV rms) of Primary winding (Dry)	275 kV rms		
26	One minute power frequency withstand voltage of secondary winding (kV rms)	3 kV		
27 a)	Minimum total Creepage distance of insulator bushing (mm)	25mm/kV Porcelain Insulator / 3625 mm		
b)	Protected Creepage of distance of bushing (mm)	Not Applicable		
28	Details of Cores	Core 1	Core2	Core 3
i)	Current Ratios A/A	300-200/1-1-1A		
ii)	Output burden (VA)	20	-	20
iii)	Class of accuracy	5P20	PX	0.2S
iv)	ISF	NA	NA	≤ 5
v)	Min. knee point voltage (kpv) in volts	NA	≥40I(Rct+10)	-
vi)	Secondary resistance corrected to 75 deg.C in ohms	NA	NA	--
vii)	Max. Exciting current (mA) at Vk - 100% of knee point voltage	NA	≤30mA	-
viii)	Application			
29	Weight of oil (Kg.)	120kg ± 10% (approx.)		
30	Total Weight (Kg.)	470 ± 10% (approx.)		
31	Mounting details	450mm x 450mm (Refer GA Drawing)		
32	Suitable for altitude-Max (Meters)	1000		
33	Secondary Terminal Box Arrangement	Single door Box		

1. Minimum 300mm plinth shall be maintained for CT/PT/CVT/ Isolators/IVT in the substation during foundation works to ensure safe live to ground clearance as per IE rules.
2. Since the supply of terminal connectors is not in the scope of manufacturers as mentioned in the drawings. The EPC contractors shall be instructed to supply the same in line with CT/PT/CVT/Isolator /IVTs requirement and capatibility.

CHIEF ENGINEER/PROJECTS  
APTRANSCO/VS/Vijayawada

Variation of Tan Delta Value from 10KV um/sqrt 3 shall be not exceed 15%.