

Drawing approval subject to valid vendor registration

Item: 145kV CT

Ratio: 300/1A, 1C

Creepage: 31mm/kV

Customer: APTransco, Andhra Pradesh

List of Standard Drawings/Documents:

Sl. No.	Description	Drawing/ Doc No.
1	General Arrangement	APTR-04.31.145J1
2	Rating Plate	APTR-04.31.145J2_REV No.01
3	Terminal Box GA	APTR-04.31.145J3_REV No.01
4	Sectional View	APTR-04.31.145J4
5	GTP	--

Variation of Tan Delta Value from 10KV $\mu\text{m}/\sqrt{3}$ shall be not exceed 15%.

1. Minimum 300mm plinth shall be maintained for CT/PT/CVT/ Isolators/IVT in the substation during foundation works to ensure safe live to ground clearance as per IE rules.
2. Since the supply of terminal connectors is not in the scope of manufacturers as mentioned in the drawings. The EPC contractors shall be instructed to supply the same in line with CT/PT/CVT/Isolator /IVTs requirement and capability.

CHIEF ENGINEER/PROJECTS
APTRANSCO/VS/Vijayawada

NOTE:-1. Drawings approval subject to valid type test reports, to be checked during acceptance tests.
2. For EPC contractors only.

IF IN DOUBT ASK

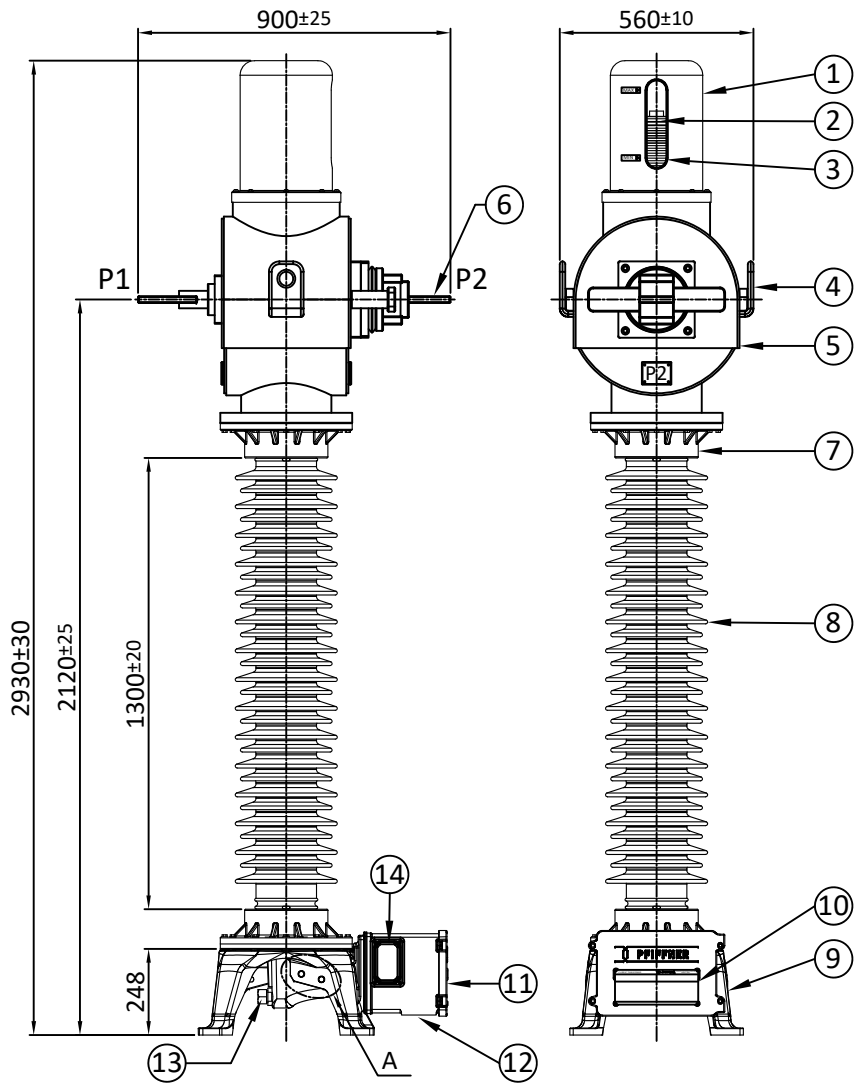

Drawing approval subject to valid vendor registration

Variation of Tan Delta Value from 10KV um/sqrt 3 shall be not exceed 15%.

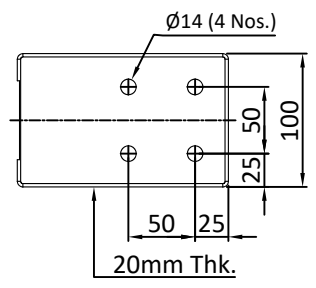

TERMINAL DETAIL

2Nos. of Ø15 Hole for Earthing Diagonally opposite

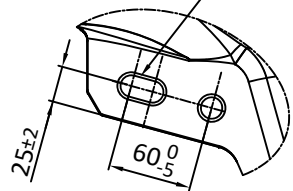

Detail 'A'

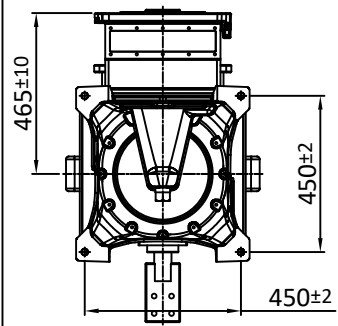

CT MOUNTING DETAIL

NO.	QTY.	DESCRIPTION	MATERIAL
01	01	BELLOWS COVER	ALUMINIUM
02	01	BELLOWS	STAINLESS STEEL
03	01	BELLOW LEVEL INDICATOR	POLYCARBONATE
04	02	LIFTING LUG	ALUMINIUM
05	01	HOUSING	ALUMINIUM
06	02	PRIMARY TERMINAL	ALUMINIUM
07	02	INSULATOR FLANGE	ALUMINIUM
08	01	INSULATOR	PORCELAIN
09	01	BASE	ALUMINIUM
10	01	RATING PLATE	ALUMINIUM
11	01	TERMINAL BOX	ALUMINIUM
12	01	GLAND PLATE	ALUMINIUM
13	01	OIL SAMPLING VALVE	STEEL GALVANISED
14	01	TAN DELTA MEASUREMENT TERMINAL	BRASS

TOTAL WEIGHT : 380 kg ±10%
TOTAL OIL WEIGHT : 90 kg ±10%
CREEPAGE DISTANCE : ≥4495 mm

CHIEF ENGINEER/PROJECTS
APTRANSCO/VS/Vijayawada

Customer : TRANSMISSION CORPORATION OF ANDRA PRADESH LTD.

REV.NO.	DESCRIPTION	APPV'D	REV. DATE
GEN. TOL : NA	MATERIAL : NA		
WEIGHT : NA			
NAME	SIGN	DATE	SPEC : NA
DRAWN	M.D.	09.03.2023	FINISH : NA
CHK'D	M.C.	09.03.2023	SCALE : N.T.S.
APPV'D	R.P.	09.03.2023	SHEET SIZE : A3
PIFFNER Instrument Transformers Pvt.Ltd. NASHIK, INDIA			TITLE : GENERAL ARRANGEMENT 145KV CT
SHEET 1 OF 1		REV. NO. : 00	

This document must not be copied without our written permission and the content and nor be used for any unauthorised purpose. Contravention will be prosecuted. © PFIFFNER

NOTE:-1. Drawings approval subject to valid type test reports,

to be checked during acceptance tests.

2. For EPC contractors only.

IF IN DOUBT ASK

PFIFFNER Instrument Transformers Pvt.Ltd. NASHIK, INDIA **CURRENT TRANSFORMER**

CUSTOMER : TRANSMISSION CORPORATION OF ANDRA PRADESH LTD.		PO No. : -----	
YEAR : ----	SPECIFICATION : IS 16227, IEC 61869	H.S.V. : 145kv	SERIAL NO. : -----
TYPE : JOF 145 W	STC. : 31.5 kA for 1S	INSULATION LEVEL : 275 kv/650 kvp	RATED PRIMARY CURRENT : 300 A
FREQUENCY : 50 Hz	Idyn : 78.75 kAp	TOTAL CREEPAGE DISTANCE : ≥ 4495mm	RATED CONT. THERMAL CURRENT : 360 A
CORE NO.	1		
RATIO	300/1		
PRI. TERMINAL	P1-P2		
SEC. TERMINAL	1S1-1S2		
VA	5		
CLASS	0.2S		
ISF/ALF	≤5		
Vk (V) min.	--		
max Iexc at Vk (mA)	--		
Rct (Ω)	--		
Total weight	380 ±10% kg	Oil weight	90 ±10% kg

Dimensions: 234±0.2 (width), 100 (height), 94±0.2 (height to top), 240 (width to center), Ø1.7 (04 Nos.) (hole diameter)

CHIEF ENGINEER/PROJECTS
APTRANSCO/VS/Vijayawada

Variation of Tan Delta Value from 10KV um/sqrt 3 shall be not exceed 15%.

PFIFFNER Instrument Transformers Pvt.Ltd. NASHIK, INDIA **CURRENT TRANSFORMER**

SERIAL NO. : -----	
YEAR : ----	

Dimensions: 140±0.2 (width), 105 (height), 98±0.2 (height to top), 148 (width to center), Ø1.7 (04 Nos.) (hole diameter)

1. Minimum 300mm plinth shall be maintained for CT/PT/CVT/ Isolators/IVT in the substation during foundation works to ensure safe live to ground clearance as per IE rules.
2. Since the supply of terminal connectors is not in the scope of manufacturers as mentioned in the drawings. The EPC contractors shall be instructed to supply the same in line with CT/PT/CVT/Isolator /IVTs requirement and capatibility.

Customer : TRANSMISSION CORPORATION OF ANDRA PRADESH LTD.

CAUTION : - Short all sec. terminals when not in use or before disconnecting burdens. Also check bellows position.
- Capacitance & tan delta terminal 'T_δ' shall always be connected to earth & disconnect only for measurement.

Drawing approval subject to valid vendor registration

01	AS PER CUSTOMER COMMENTS.			CHM	18.04.2023
REV.NO.	DESCRIPTION			APPV'D	REV. DATE
GEN. TOL : NA		MATERIAL : 1mm thick Aluminium metal photo			
WEIGHT : NA		SPEC : NA			
DRAWN	M.D.	09.03.2023	ALL DIMENSION ARE IN MM. UNLESS OTHRWISE SPECIFIED.		
CHK'D	M.C.	09.03.2023	SCALE : N.T.S.		
APPV'D	R.P.	09.03.2023	SHEET SIZE : A3		
PFIFFNER Instrument Transformers Pvt.Ltd. NASHIK, INDIA			TITLE : RATING PLATE 145 kv CT		DWG NO. APTR-04.31.145J2
			SHEET 1 OF 1		REV. NO. : 01

This document must not be copied without our written permission and the content and nor be used for any unauthorised purpose. Contravention will be prosecuted.

NOTE:-1. Drawings approval subject to valid type test reports to be checked during acceptance tests.
2. For EPC contractors only.

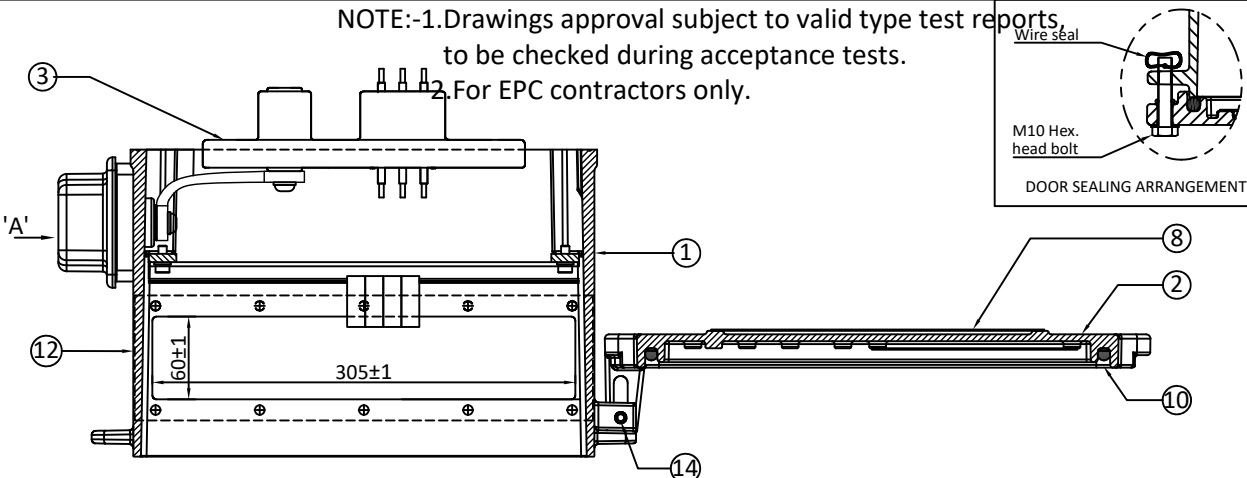

SR.NO.	DESCRIPTION	QTY.	MATERIAL
1	TERMINAL BOX	1	ALUMINIUM
2	TERMINAL BOX DOOR	1	ALUMINIUM
3	SECONDARY LEAD OUT	1	EPOXY
4	STUD TYPE TERMINAL BLOCK (KBT M4)	2+2 SPARE	MAKE - ELMEX
5	TERMINAL CARRIER RAIL	2	STEEL
6	GLAND PLATE	1	ALUMINIUM
7	GLAND PLATE GASKET	1	NEOPRENE RUBBER
8	RATING PLATE	1	ALUMINIUM
9	SCHEMATIC DIAGRAM PLATE	1	ALUMINIUM
10	DOOR GASKET	1	EPDM RUBBER
11	DOOR EARTHING CABLE	1	PVC INSULATED COPPER CABLE
12	WARNING STICKER	1	ALUMINIUM
13	TAN DELTA (T _δ) MEASUREMENT TERMINAL	1	BRASS
14	HINGES	2	S.S. TENSION PIN
15	TAN DELTA EARTH LINK	1	COPPER (NICKEL PLATED)

Variation of Tan Delta Value from 10KV um/sqrt 3 shall be not exceed 15%.

DEGREE OF PROTECTION : IP 55

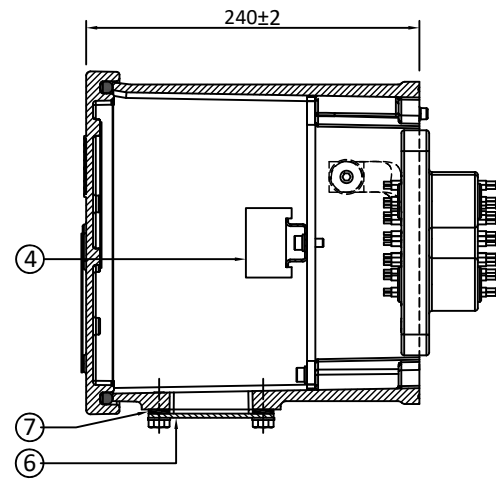
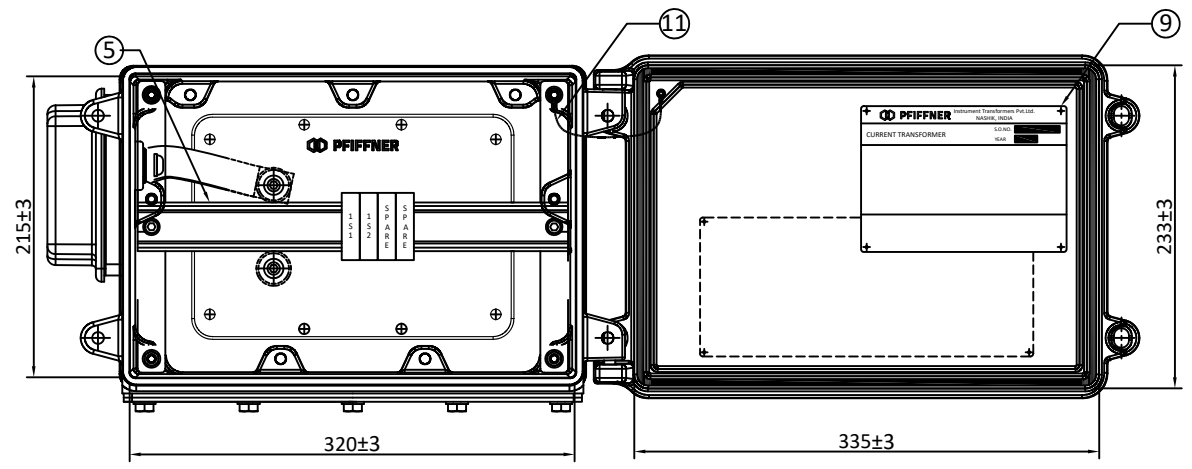

Drawing approval subject to valid vendor registration

Customer : TRANSMISSION CORPORATION OF ANDRA PRADESH LTD.

This document must not be copied without our written permission and the content and nor be used for any unauthorised purpose. Contravention will be prosecuted. PFIFFNER

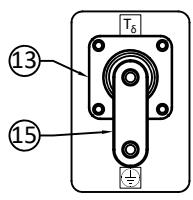

Detail 'A'

WARNING
"T_δ" TERMINAL - DO NOT OPEN WHEN IN SERVICE

Item : 12

CHIEF ENGINEER/PROJECTS
APTRANSCO/VS/Vijayawada

REV.NO.	DESCRIPTION	CHM	REV. DATE
01	AS PER CUSTOMER COMMENTS.	CHM	18.04.2023
GEN. TOL : NA		MATERIAL : NA	
WEIGHT : NA		ALL DIMENSION ARE IN MM. UNLESS OTHRWISE SPECIFIED.	
DRAWN	M.D.	09.03.2023	SPEC : NA
CHK'D	M.C.	09.03.2023	FINISH : NA
APPV'D	R.P.	09.03.2023	SCALE : N.T.S.
TITLE : TERMINAL BOX GA 145KV CT		SHEET SIZE : A3	
PFIFFNER Instrument Transformers Pvt.Ltd. NASHIK, INDIA		DWG NO. APTR-04.31.145J3	
SHEET 1 OF 1		REV. NO. : 01	

NOTE:-1. Drawings approval subject to valid type test reports, to be checked during acceptance tests.
2. For EPC contractors only.

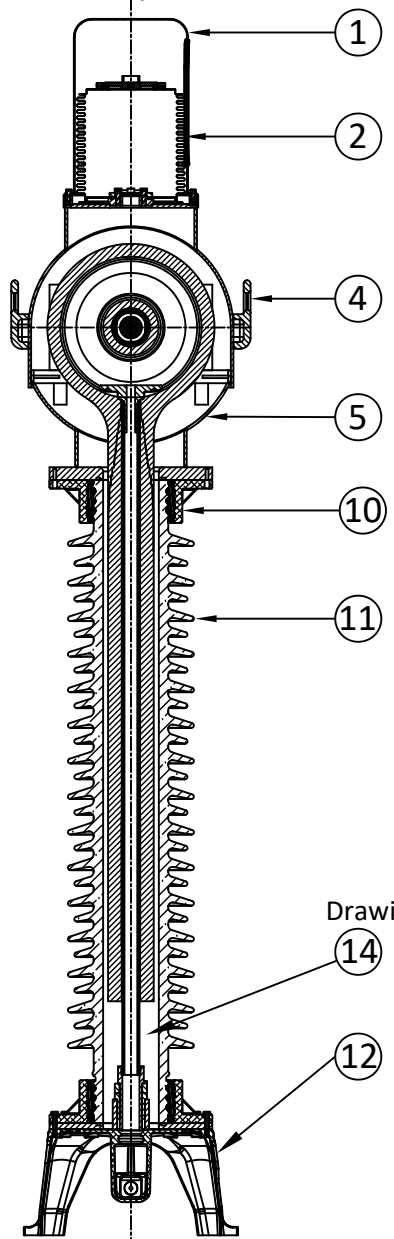
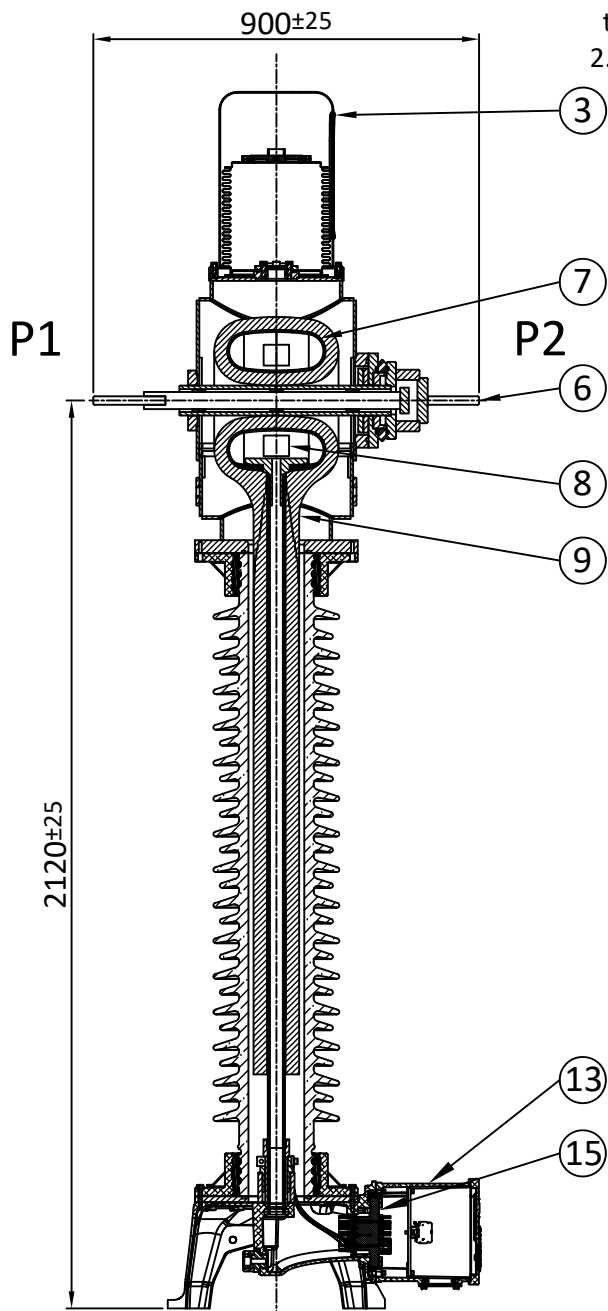

NO.	QTY.	DESCRIPTION	MATERIAL
01	01	BELLOWS COVER	ALUMINIUM
02	01	BELLOWS	STAINLESS STEEL
03	01	BELLOW LEVEL INDICATOR	POLYCARBONATE
04	02	LIFTING LUG	ALUMINIUM
05	01	HOUSING	ALUMINIUM
06	02	PRIMARY TERMINAL	ALUMINIUM
07	01	CORE BOX	ALUMINIUM
08	01	SECONDARY CORES	CRGO & NANO
09	01	ACTIVE PART	OIL IMPREGNATED PAPER
10	02	INSULATOR FLANGE	ALUMINIUM
11	01	INSULATOR	PORCELAIN
12	01	BASE	ALUMINIUM
13	01	TERMINAL BOX	ALUMINIUM
14	--	INSULATING OIL	EHV Grade - MINERAL OIL
15	01	SECONDARY LEADOUT	EPOXY

Notes:

- Insulating oil shall be EHV Grade as per IS 335, IEC 296
- Core : CRGO Si-Fe/ Equivalent high permeability material, MU- Metal, NANO - crystalline
- Secondary winding - Enamelled copper

CHIEF ENGINEER/PROJECTS
APTRANSCO/VS/Vijayawada

Drawing approval subject to valid vendor registration

Customer : TRANSMISSION CORPORATION OF ANDRA PRADESH LTD.

This document must not be copied without our written permission and the content and nor be used for any unauthorised purpose. Contravention will be prosecuted. © PFIFFNER

Variation of Tan Delta Value from 10KV um/sqrt 3 shall be not exceed 15%.

REV.NO.	DESCRIPTION				APPV'D	REV. DATE
GEN. TOL. : NA		MATERIAL : NA				
WEIGHT : NA		SPEC : NA				
DRAWN	M.D.	DATE	09.03.2023	ALL DIMENSION ARE IN MM. UNLESS OTHRWISE SPECIFIED.		
CHK'D	M.C.	DATE	09.03.2023	SCALE : N.T.S.		
APPV'D	R.P.	DATE	09.03.2023	SHEET SIZE : A3		
PFIFFNER Instrument Transformers Pvt.Ltd. NASHIK, INDIA				TITLE :		DRG NO.
				SECTIONAL VIEW		APTR-04.31.145J4
				145KV CT		SHEET 1 OF 1
						REV. NO. : 00

Variation of Tan Delta Value from 10KV um/sqrt 3 shall be not exceed 15%.

Annexure-A
GUARANTEED TECHNICAL PARTICULARS FOR CURRENT TRANSFORMERS

JOF 145 W OUTDOOR CURRENT TRANSFORMERS
(145kV 300A CT, 1 Core 31mm Creepage)

CHIEF ENGINEER/PROJECTS
APTRANSCO/VS/Vijayawada

Sl.No	Particulars	Description
1	Type of tank/Installation Dead/Live Tank Type	Live Tank, Single Phase, Oil Filled, Outdoor Type
2	Type of mounting	Pedestal Mounting
3	Manufacturer's Name and address and Country of Manufacture	PFIFNER Instrument Transformers Pvt Limited, Gat No. 176, 178/2, Sarul, Nashik 422010, Maharashtra, INDIA
4	Whether Conforming to IEC 61869 Standard	Yes, IEC 61869-1&2
5 a)	Primary and Secondary winding made out of	Primary - Aluminium alloy of C/S area 1250mm ² Secondary - Copper alloy of C/S area 1.168mm ²
b)	Material used for providing Primary Terminals	Aluminium
c)	Material used for providing secondary Terminals	Copper Alloy
d)	Whether Primary is Rigid Bar type in case of live tank	Yes, Rigid Bar type
6	Rated primary voltage (kV rms)	132 kV
7	Rated highest voltage (kV rms)	145 kV
8	Rated frequency (Hz)	50 Hz
9	Rated primary current (A)	300A
10	Rated secondary current (A)	1A
11	Ratio taps (on secondary side only)	On Secondary Only
12	Type of insulation	Class A
13	Seismic acceleration (g)	0.3g
14	RIV at 1.1 x Rated voltage (mv)	< 500 Micro Volts
15	Tank material and Tank coating	Aluminium Tank with Natural Finish
16	Porcelain housing and it make (Single piece only)	IEC/Modern/Ravikiran
17	Sealing (Nitrogen gas cushion/Metal Bellow)	Stainless Steel Bellows
18	Instrument security factor	≤ 5 (For Metering core)
19	Tan Delta	< 0.5%
20	Partial Discharge Level	< 5pC at 1.2 x Um /√3, < 10pC at Um (where Um is highest system voltage)
21	Rated short time withstand current for 1 sec. duration (kA rms)	31.5 kA
22	Rated dynamic withstand current (kAp)	78.75

Drawing approval subject to valid vendor registration

Sl.No	Particulars	Description
23	Rated continuous thermal current (pu) where pu = rated current	Rated Extended Primary Current 120%
24	1.2/50 micro second impulse withstand voltage (kVp)	650 kVp
25	One minute power frequency withstand voltage (kV rms) of Primary winding (Dry)	275 kV rms
26	One minute power frequency withstand voltage of secondary winding (kV rms)	3 kV
27 a)	Minimum total Creepage distance of insulator bushing (mm)	31mm/kV Porcelain Insulator / 4495 mm
b)	Protected Creepage of distance of bushing (mm)	Not Applicable
28	Details of Cores	Core 1
i)	Current Ratios A/A	300/1A
ii)	Output burden (VA)	5
iii)	Class of accuracy	0.2S
iv)	ISF	≤ 5
v)	Min. knee point voltage (kVp) in volts	-
vi)	Secondary resistance corrected to 75 deg.C in ohms	--
vii)	Max. Exciting current (mA) at V _k - 100% of knee point voltage	-
viii)	Application	
29	Weight of oil (Kg.)	120kg ± 10% (approx.)
30	Total Weight (Kg.)	470 ± 10% (approx.)
31	Mounting details	450mm x 450mm (Refer GA Drawing)
32	Suitable for altitude-Max (Meters)	1000
33	Secondary Terminal Box Arrangement	Single door Box

1. Minimum 300mm plinth shall be maintained for CT/PT/CVT/ Isolators/IVT in the substation during foundation works to ensure safe live to ground clearance as per IE rules.
2. Since the supply of terminal connectors is not in the scope of manufacturers as mentioned in the drawings. The EPC contractors shall be instructed to supply the same in line with CT/PT/CVT/Isolator /IVTs requirement and capatibility.

Variation of Tan Delta Value from 10KV um/sqrt 3 shall be not exceed 15%.

Drawing approval subject to valid vendor registration

CHIEF ENGINEER/PROJECTS
APTRANSCO/Vs/Vijayawada