



**NOTE : DRAWING APPROVAL SUBJECT TO VALID TYPE TEST REPORTS, TO BE CHECKED DURING ACCEPTANCE TESTS.**

**GTP FOR 132 KV CAPACITOR VOLTAGE TRANSFORMER**

Drawing approval subject to valid vendor registration

Rev No. 00 / Doc No. 132CVT-GTP-02

1	Name and address of manufacturer	Mehru Electrical & Mechanical Engineers Pvt. Ltd., SP-2,180,KEHRANI Industrial Area, Bhiwadi - 301019 (Rajasthan), India		
2	Manufacturer's type designation	Outdoor, Oil Cooled, Single Phase, Single Pole Insulated, Capacitor Voltage Transformer		
a)	Type of installation	Outdoor pedestal mounting		
3	Standards applicable	IS 16227 /IEC 61869		
4	Rated primary voltage Ur (kV)	132 kV/ $\sqrt{3}$		
5	Rated secondary voltage (V)	110 V/ $\sqrt{3}$		
a)	Rated Transformation Ratio	132kV/ $\sqrt{3}$ /110V/ $\sqrt{3}$		
6	Number of secondary	Three		
7	Rated frequency (Hz)	50 Hz		
8	Rated output of each secondary winding (VA)	Winding-1	Winding -2	Winding-3
		50 VA	50 VA	50 VA
9	simultaneous burden (VA)	50 VA	50 VA	50 VA
10	Rated total thermal burden (VA)	300VA		
11	Highest system voltage (kV)	145 kV		
12	Rated voltage factor and corresponding rated time	1.2 Continuous & 1.5 for 30 Seconds		
13	Accuracy class of each secondary winding	Winding-1	Winding -2	Winding-3
		3P	3P	0.2
14	Capacitance			
	i) of high voltage capacitor (pF)	5200pF		
	ii) of intermediate voltage capacitor (pF)	49500pF		
15	Equivalent Capacitance (pF)	4400pF(+10%-5%)		
16	Natural frequency of CVT (kHz)	> 500 kHz		
17	Self tuning frequency of CVT (kHz)	> 500 kHz		
18	Band width (kHz)	40kHz to 500kHz		
19	Maximum Temperature over ambient (50 Deg.C)	50 Deg. C		
20	One minute power frequency test voltage of secondary winding (kV rms)	3 kV		
21	One minute power frequency test voltage of H.F. terminal (kV rms)	4 kV		
22	One minute power frequency test voltage of (kV rms) (dry & wet)	275 kV		
23	1.2/50 micros impulse withstand test voltage of Capacitor (kVp)	650 kVp		
24	250/2500 micros switching surge withstand voltage of capacitor (dry & wet) (kVp)	NA Chief Engineer (Projects)		
25	Max. Radio Interference voltage at 1.1 Ur/Root 3 at 1.0 MHz (Micro volts)	< 1000 Micro Volts APTransco		
26	Total weight (kg)	365 KGS.(Approx)		
27	Quantity of oil	15 kgs. FOR CAPACITOR UNIT (IEC-60867) SYNTHETIC OIL 60 kgs. FOR EMU (IEC-60296) MINERAL OIL		
28	Whether CVTs are hermetically sealed if so how	Yes, SS Bellow		

1) Minimum 300mm plinth shall be maintained for CT/PT/CVT/Isolators in the substation during foundation works to ensure safe live to ground clearances as per IE rules.

2) Since the supply of terminal connectors is not in the scope of manufacturer as mentioned in the drawings, the EPC contractors shall be instructed to supply the same in line with CT/PT/CVT/Isolators requirement and compatibility.

29	Whether similar equipment is type tested	We confirm
30	Total Creepage Distance	4495 mm (minimum)
31	Primary terminal	30 DIA , 80mm long
32	Mounting Dimension	450±5 x 450±5, 20±2 Dia
33	Siesmic Acceleration	0.3g
34	Cantilever Strength	350kgf
35	Range of frequency for which accuracy are valid	Metering = 99% to 101% (49.5 Hz to 50.5 Hz) & protection = 96% to 102 % (48 Hz to 51 Hz)
36	Type of Oil Used	for CVD - Synthetic Oil for EMU - Mineral Oil as per IS 335
37	Dielectric material for capacitor unit	1. Capacitor tissue paper 2. BOPP Films (Biaxially oriented plain polypropelene film)
38	Equivalent series resistance over entire range	< 40 Ohms
39	Partial Discharge	at Um = 10pC & 1.2 Um/root 3 = 5pC (Max.)
40	Tan Delta	<0.5%
41	Stray capacitance & Conductance	200pF & 20µS (Max.)
42	Maximum Altitude	1000 Mtrs
43	IP protection for terminal box	IP-55
44	Insulation class	Class "A"
45	Minimum clearance between phases recommended (mm)	Not in our scope
46	Minimum center to center spacing recommended (mm)	Not in our scope
47	Minimum distance from nearby earthed objects (mm)	Not in our scope
48	Tank material & Tank coating	Tank- M.S. & Tank coating- Hot dip galvanized
49	Hardware exposed to atmosphere	Hot Dip Galvanized

NOTE : DRAWING APPROVAL SUBJECT TO VALID TYPE TEST REPORTS, TO BE CHECKED DURING ACCEPTANCE TESTS.

- 1) Minimum 300mm plinth shall be maintained for CT/PT/CVT/Isolators in the substation during foundation works to ensure safe live to ground clearances as per IE rules.
- 2) Since the supply of terminal connectors is not in the scope of manufacturer as mentioned in the drawings, the EPC contractors shall be instructed to supply the same in line with CT/PT/CVT/Isolators requirement and compatibility.

Chief Engineer (Projects)

APTransco

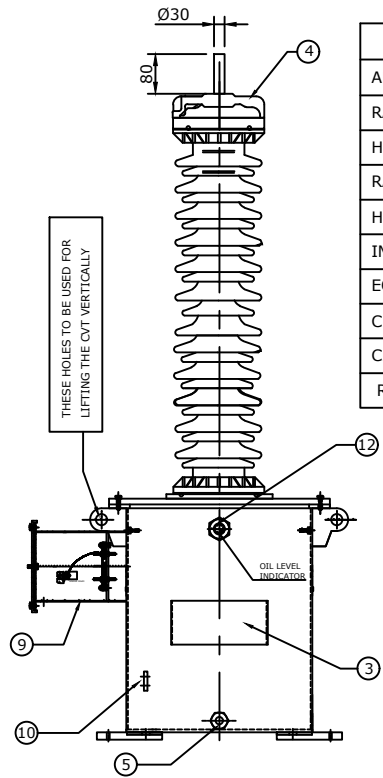
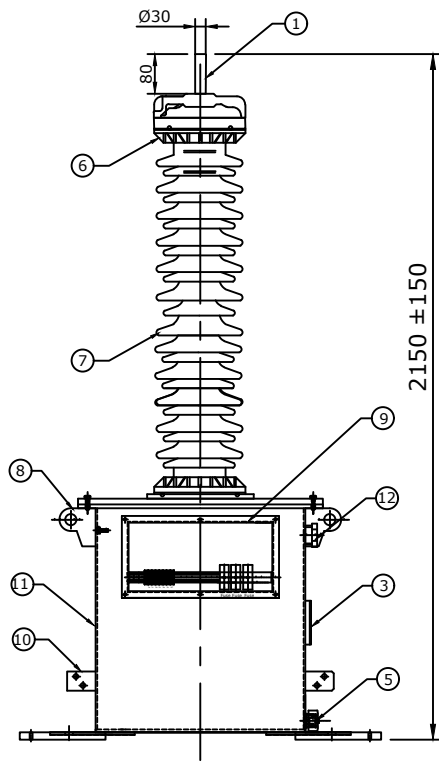

**TECHNICAL DETAILS :-**

APPLICABLE STANDERED	IS : 16227/IEC-61869
RATED VOLTAGE	132kV/√3
HIGHEST SYSTEM VOLTAGE	145 kV
RATED FREQUENCY	50 Hz
H.V. TEST VOLTAGE	275kV rms for 1 Min
IMPLUSE TEST VOLTAGE	650 kVp
EQUIVALENT CAPACITANCE	4400pF (+10% -5%)
C1-PRIMARY CAPACITANCE	5200pF (Approx)
C2-SECONDARY CAPACITANCE	49500pF (Approx)
RIV AT 156 kV	≤ 1000 μV

S.No.	DESCRIPTION	QTY	MATL
1	H.T TERMINAL	1	COPPER NICKEL COATED
2	OIL FILLING PLUG	2	BRASS/M.S(HDG)
3	NAME AND RATING PLATE	1	AL. ANODIZED
4	HOOD	1	ALUMINUM
5	OIL DRAIN PLUG	1	M.S(HDG)
6	BUSHING CLAMP	2	GI/CI
7	BUSHING	1	PORCELAIN
8	LIFTING HOOK	4	M.S(HDG)
9	SECONDARY TERMINAL BOX	1	M.S(HDG)
10	EARTHING TERMINAL (FLAT)	2	M.S(HDG)
11	TANK WITH COVER (EMU)	1	M.S(HDG)
12	OIL LEVEL INDICATOR	1	AL./BRASS

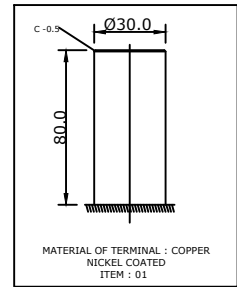
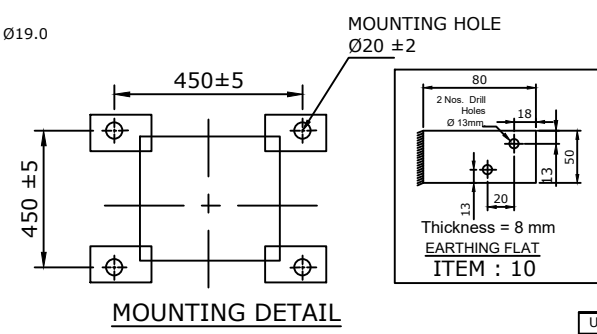
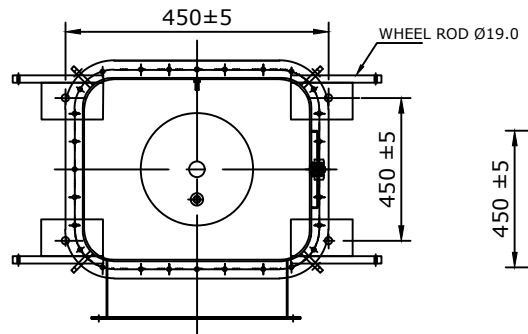

**NOTES :-**

- NOMINAL CREEPAGE DISTANCE - 4495 mm.
- OIL QUANTITY :-  
15 kgs. FOR CAPACITOR UNIT (IEC-60867) SYNTHETIC OIL  
60 kgs. FOR EMU (IEC-60296) MINERAL OIL
- TOTAL WEIGHT OF CVT :- 365 KGS.
- WEIGHTS INDICATED ARE APPROXIMATE
- ALL FERROUS PARTS EXPOSED TO THE ATMOSPHERE SHALL BE HOT DIP GALVANIZED AS PER IS 4759 & 2629.
- MAKE OF BUSHING : IEC/ABIL/MODERN/BHEL/CJI
- INSULATION CLASS : 'A'
- FOR GASKET (CORK) JOINTS WHEREVER USED, NITRITE BUTYL RUBBER GASKETS SHALL BE USED. THE GASKET SHALL BE FITTED IN PROPERLY MACHINED GROOVE WITH ADEQUATE SPACE FOR ACCOMMODATING THE GASKET UNDER COMPRESSION.

Drawing approval subject to valid vendor registration

Chief Engineer (Projects)

APTransco

R0	FOR APPROVAL	27.05.2023
REV.	REVISION DESCRIPTION	DATED INITIALS

UNLESS OTHERWISE SPECIFIED 1. ALL DIMENSIONS IN mm 2. TOLERANCE WHEREVER NOT INDICATED : ±5%	DGN.	NAME	DATE	MATERIAL  AS ABOVE	<b>MEHRU</b> MEHRU ELECTRICAL AND MECHANICAL ENGINEERS PRIVATE LIMITED.
	DRN.	SPS	27.05.2023		
	CHD.	SWET	27.05.2023		
	SCALE:	BLS	27.05.2023		
TITLE: GENERAL ARRANGEMENT DRAWING FOR 132kV CAPACITOR VOLTAGE TRANSFORMER				SCALE: N.T.S	
DRAWING NO.: ME-132CVT-GA-02					

**MEHRU** CAPACITOR VOLTAGE TRANSFORMER

MAKE TO IS : 16227/IEC-61869

MAXIMUM VOLTAGE	145kV	RATED PRIMARY VOLTAGE	132kV/√3
RATED LINE VOLTAGE	132 kV	WDG I	RATED SECONDARY VOLTAGE 110 V / √3
EQUIVALENT CAPACITANCE	4400pF(+10%-5%)		SECONDARY CONNECTION 1a -1n
FREQUENCY	50 Hz		BURDEN 50 VA
OVERVOLTAGE FACTOR	1.5 FOR 30 SECONDS		CLASS 3P
CONTINUOUS VOLTAGE FACTOR	1.2	WDG II	RATED SECONDARY VOLTAGE 110 V / √3
TEMPERATURE CATEGORY	-10°C to + 50°C		SECONDARY CONNECTION 2a -2n
INSULATION LEVEL	275/650(kVrms/kVp)		BURDEN 50 VA
SIMULTANEOUS BURDEN	50VA-50VA-50VA		CLASS 3P
THERMAL BURDEN	300 VA	WDG III	RATED SECONDARY VOLTAGE 110 V / √3
YEAR OF MFD.			SECONDARY CONNECTION 3a -3n
			BURDEN 50 VA
			CLASS 0.2

NOMINAL INTERMEDIATE VOLTAGE -8kV  
 NOMINAL CREEPAGE DISTANCE - 4495mm.  
 SERIAL No. [ ]  
 PO. NO. [ ]

**CAUTION : WHEN HF TERMINAL IS NOT IN USE IT SHOULD BE SHORTED TO EARTH.**

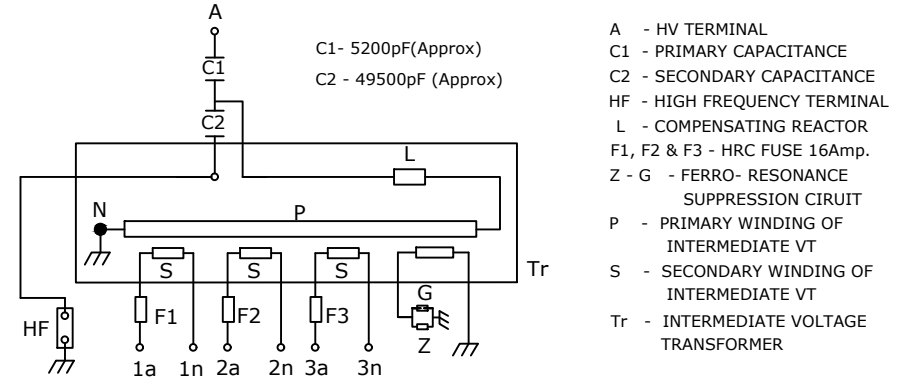

MADE IN INDIA BY:  
**MEHRU ELECTRICAL AND MECHANICAL ENGINEERS (P) LTD.**  
 SP-2/180, RIICO INDUSTRIAL AREA KEHRANI EXT. BHIWADI-301019, (RAJASTHAN)

Drawing approval subject to valid vendor registration

**NOTE : DRAWING APPROVAL SUBJECT TO VALID TYPE TEST REPORTS, TO BE CHECKED DURING ACCEPTANCE TESTS.**

**NOTES:-**

- SERIAL NO. SHALL BE ENGRAVED BEFORE DISPATCH.
- THICKNESS OF RATING PLATE 1.2 mm.
- MATERIAL OF NAME PLATE SHALL BE ALUMINUM ANODISED.

Chief Engineer (Projects)

APTransco

190 ±15

180 ±10

UNLESS OTHERWISE SPECIFIED 1. ALL DIMENSIONS IN mm 2. TOLERANCE WHEREVER NOT INDICATED : ±5%	DGN.	NAME	DATE	MATERIAL ALU. ANODISED	 MEHRU ELECTRICAL AND MECHANICAL ENGINEERS PRIVATE LIMITED. SCALE: N.T.S  DRAWING NO.: ME-132CVT-NP-02
	DRN.	SWET	27.05.2023		
	CHD.	BLS	27.05.2023		
	SCALE:	N.T.S			
TITLE: NAME PLATE DRAWING FOR 132kV CAPACITOR VOLTAGE TRANSFORMER					
REV.	FOR APPROVAL	27.05.2023			
	REVISION DESCRIPTION	DATED INITIALS			

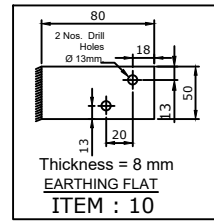
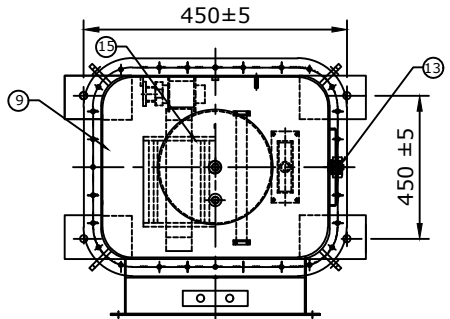
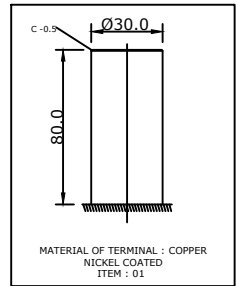
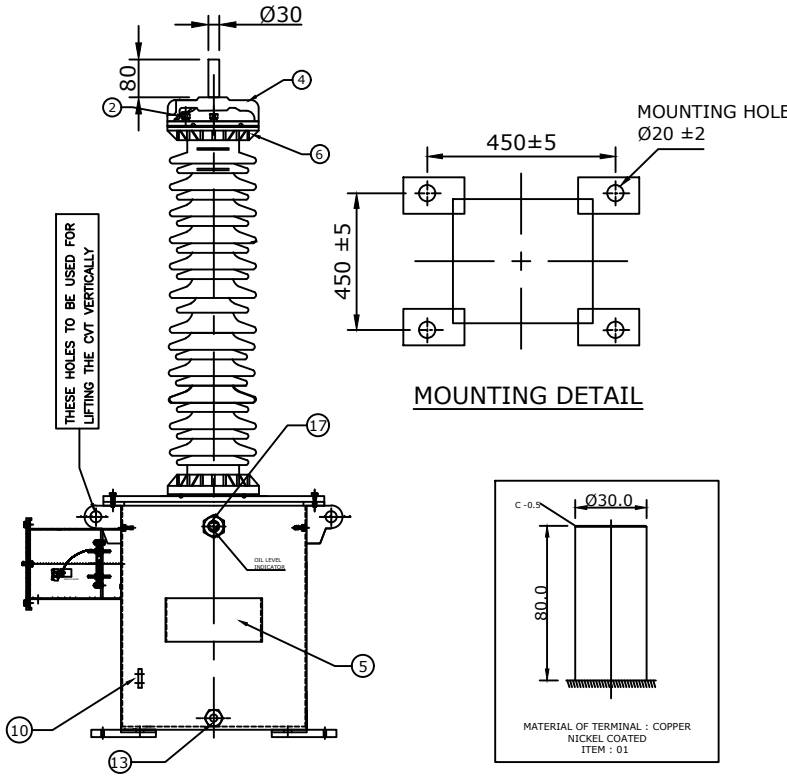
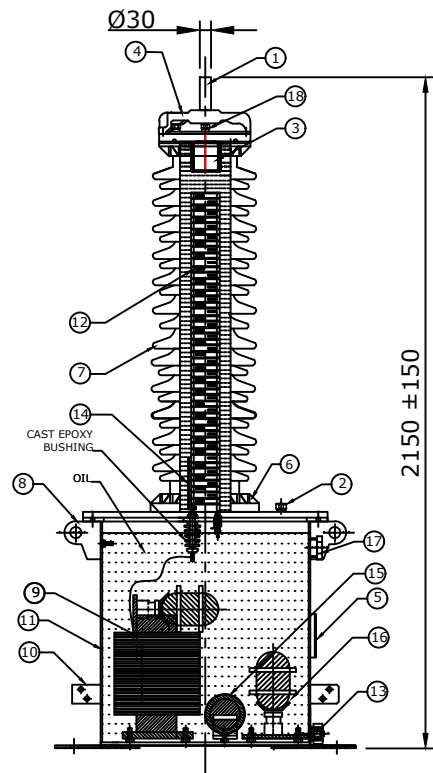

NOTES :-

1. NOMINAL CREEPAGE DISTANCE - 4495 mm.
2. OIL QUANTITY :-  
15 kgs. FOR CAPACITOR UNIT (IEC-60867) SYNTHETIC OIL  
60 kgs. FOR EMU (IEC-60296) MINERAL OIL
3. TOTAL WEIGHT OF CVT :- 365 KGS.
4. WEIGHTS INDICATED ARE APPROXIMATE
5. ALL FERROUS PARTS EXPOSED TO THE ATMOSPHERE SHALL BE APTransco HOT DIP GALVANIZED AS PER IS 4759 & 2629.
6. MAKE OF BUSHING : IEC/ABIL/MODERN/BHEL/CJI
7. INSULATION CLASS : 'A'

Chief Engineer (Projects)

APTransco

S.No.	DESCRIPTION	QTY	MATL
1	H.T TERMINAL	1	COPPER NICKEL COATED
2	OIL FILLING PLUG	2	BRASS/M.S(HDG)
3	BELLOW	1	S.S
4	HOOD	1	ALUMINUM
5	NAME AND RATING PLATE	1	AL. ANODIZED
6	BUSHING CLAMP	2	GI/CI
7	BUSHING	1	PORCELAIN
8	LIFTING HOOK	4	M.S(HDG)
9	INDUCTION VOLTAGE TRANSFORMER	1	CRGO/COPPER
10	EARTHING TERMINAL (FLAT)	2	M.S(HDG)
11	TANK WITH COVER (EMU)	1	M.S(HDG)
12	CAPACITOR ELEMENT	1	CU./PAPER
13	OIL DRAIN PLUG	1	M.S(HDG)
14	VOLTAGE DIVIDER TAP CONNECTION	1	STD
15	COMPENSATING REACTOR	1	STD
16	FERRO RESONANCE SUPPRESSION CIRCUIT	1	STD
17	OIL LEVEL INDICATOR	1	AL./BRASS
18	NITROGEN RELEASE VALVE	1	BRASS

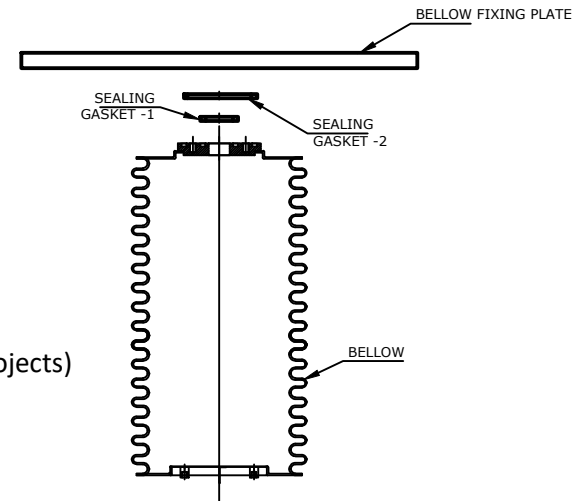

REV.	REVISION DESCRIPTION	DATED INITIALS
R0	FOR APPROVAL	27.05.2023

UNLESS OTHERWISE SPECIFIED		NAME	DATE	MATERIAL	 MEHRU ELECTRICAL AND MECHANICAL ENGINEERS PRIVATE LIMITED.
1. ALL DIMENSIONS IN mm	DGN.	SPS	27.05.2023	AS ABOVE	
2. TOLERANCE WHEREVER NOT INDICATED : ±5%	DRN.	SWET	27.05.2023		
	CHD.	BLS	27.05.2023		
		SCALE:	N.T.S		
TITLE:					SCALE:
SECTIONAL ARRANGEMENT DRAWING FOR 132kV CAPACITOR VOLTAGE TRANSFORMER					N.T.S
					DRAWING NO.:
					ME-132CVT-SE-02

Drawing approval subject to valid vendor registration

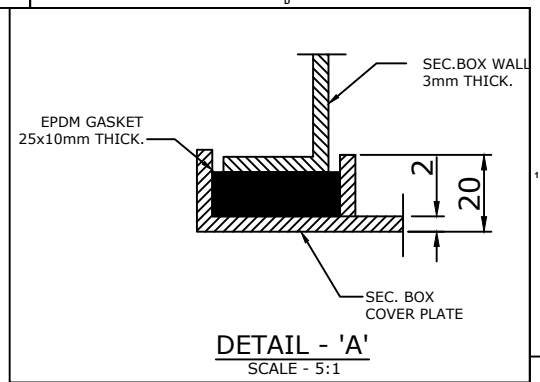
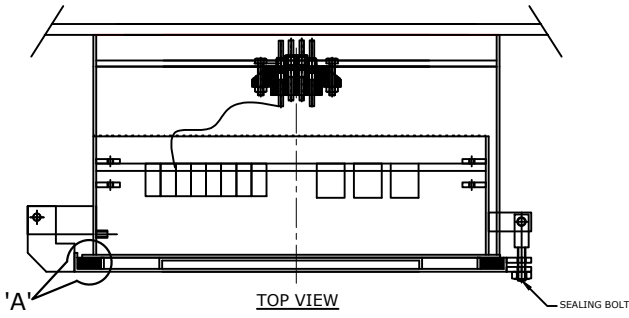

Chief Engineer (Projects)

APTransco

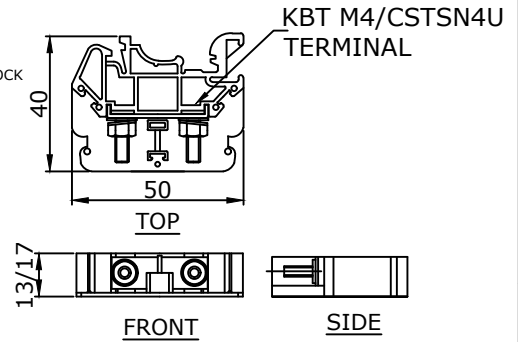
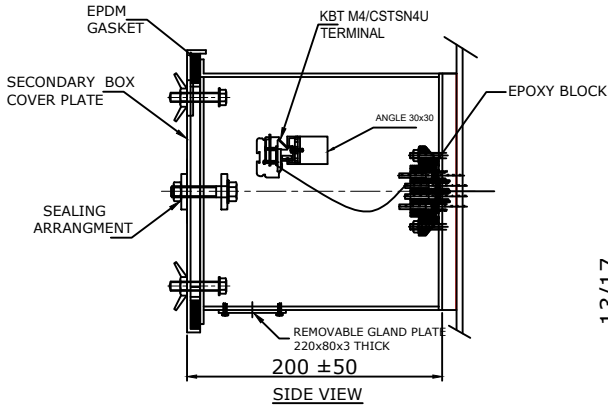
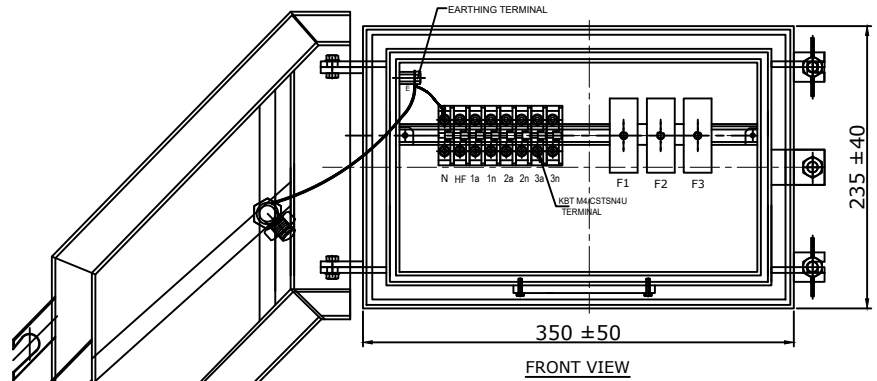

MATERIAL : POLYAMIDE  
MAKE : ELEMEX/CONNECTWELL  
TERMINAL (DETAIL)

HF : TAN DELTA TESTING TERMINAL  
N : NEUTRAL TERMINAL  
E : EARTHING TERMINAL  
F1, F2 & F3 : FUSE 16 Amp.

NOTES:-

1. SECONDARY TERMINAL BOX SHALL BE PROVIDED WITH REMOVABLE GLAND PLATE WITHOUT HOLE.
2. SECONDARY TERMINAL BOX SHALL BE PROVIDED WITH COVER.
3. M.S(HDG) SHEET THICKNESS FOR TERMINAL BOX SHALL BE 3.0mm. & FOR COVER 2.0mm.
4. MATERIAL OF GASKET: EPDM, 10 mm. THICK.
5. DEGREE OF PROTECTION : IP 55.
6. FOR GASKET (CORK) JOINTS WHEREVER USED, NITRITE BUTYL RUBBER GASKETS SHALL BE USED. THE GASKET SHALL BE FITTED IN PROPERLY MACHINED GROOVE WITH ADEQUATE SPACE FOR ACCOMMODATING THE GASKET UNDER COMPRESSION.

R0	FOR APPROVAL	27.05.2023
REV.	REVISION DESCRIPTION	DATED INITIALS

UNLESS OTHERWISE SPECIFIED 1. ALL DIMENSIONS IN mm 2. TOLERANCE WHEREVER NOT INDICATED : ±5%	DGN.	NAME	DATE	MATERIAL M.S	MEHRU ELECTRICAL AND MECHANICAL ENGINEERS PRIVATE LIMITED.
	DRN.	SPS	27.05.2023		
	CHD.	SWET	27.05.2023		
	SCALE:	BLS	27.05.2023		
TITLE:			N.T.S		SCALE: N.T.S DRAWING NO: ME-132CVT-STB-02
SECONDARY TERMINAL BOX DRAWING FOR 132KV CAPACITOR VOLTAGE TRANSFORMER					

Drawing approval subject to valid vendor registration

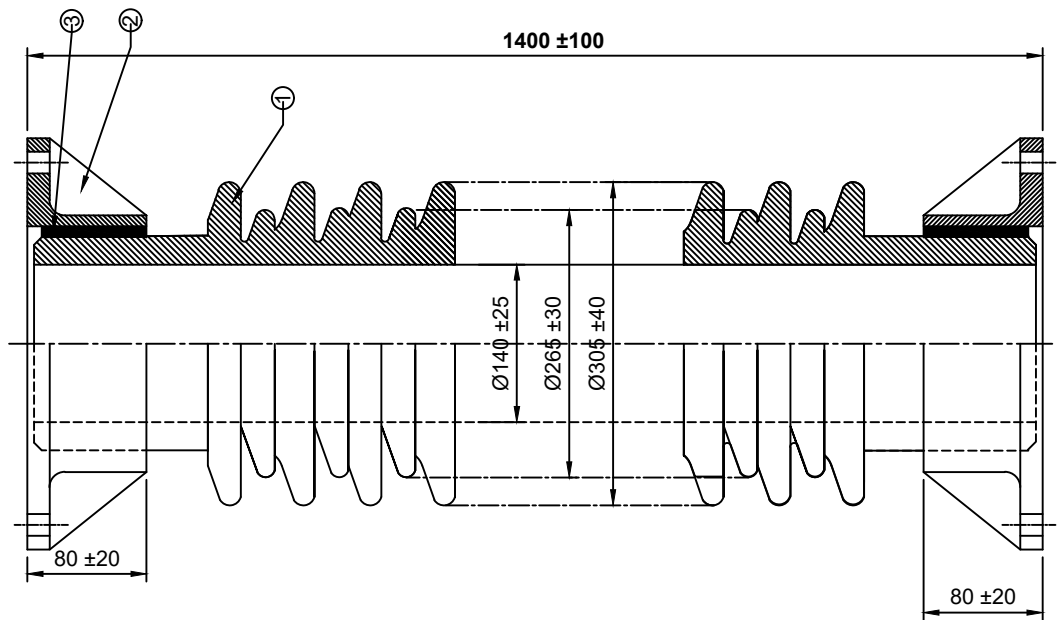

FRONT VIEW

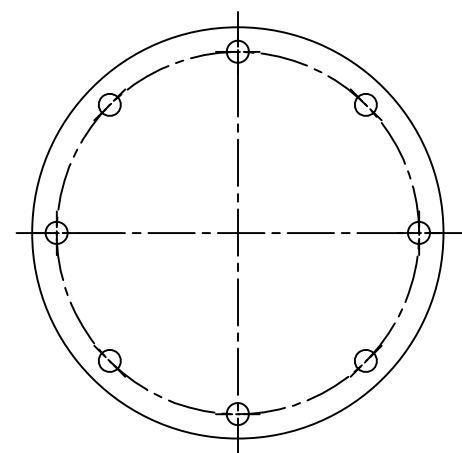

BOTTOM VIEW

\* MAKE OF BUSHING : IEC/MODERN/BHEL/ABIL/CJI

1. Electrical Insulation level :-275 kV/650 kV(P)
2. Nominal creepage distance -4495 mm.
3. Cantilever load :- 350kgf
4. Colour of Glaze : BROWN.
5. Unspecified test & Tolerance as per IEC: 62155, IS:5621-1980

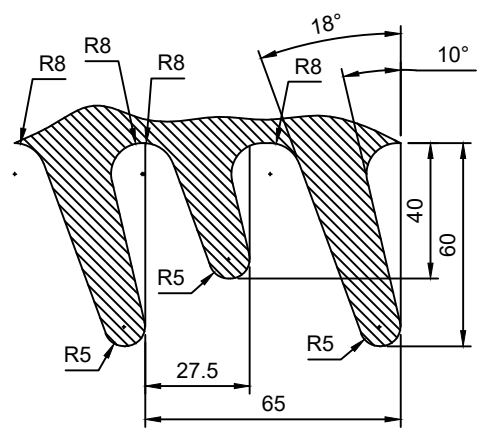

Shed Profile

Chief Engineer (Projects)

APTransco

Item No.	Description	Material
1	INSULATOR	Porcelain
2	FLANGES	MCI/SGI/ALU.
3	CEMENT	Portland

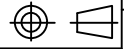
UNLESS OTHERWISE SPECIFIED 1. ALL DIMENSIONS IN mm 2. TOLERANCE WHEREVER NOT INDICATED : ±5%	DGN.	NAME	DATE	MATERIAL PORCELAIN	 MEHRU ELECTRICAL AND MECHANICAL ENGINEERS PRIVATE LIMITED.
	DRN.	SPS	22.05.2023		
	CHD.	SWET	22.05.2023		
	SCALE:	BLS	22.05.2023	N.T.S	
TITLE: HOLLOW PORCELAIN BUSHING DRAWING FOR 132KV CAPACITOR VOLTAGE TRANSFORMER					SCALE: N.T.S 
REV. FOR APPROVAL 22.05.2023 REV. REVISION DESCRIPTION DATED INITIALS					DRAWING NO.: ME-132CVT-BUSH-02