

4601542/2021/EEMRT-ENE51

LC2 SHELL

IF IN DOUBT ASK

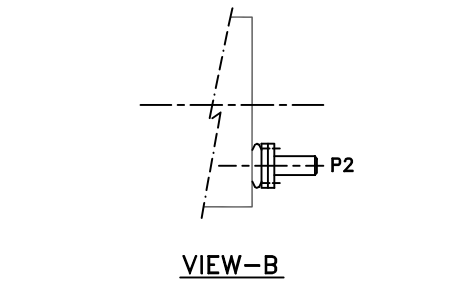
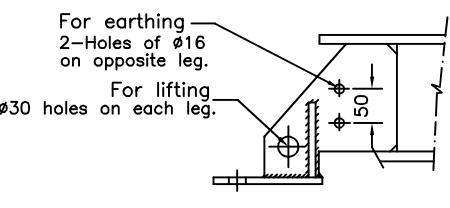
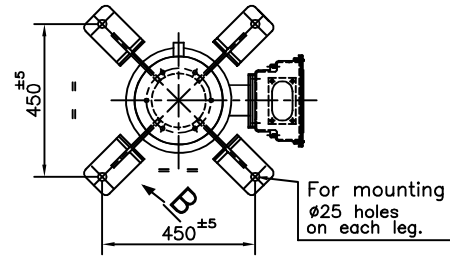
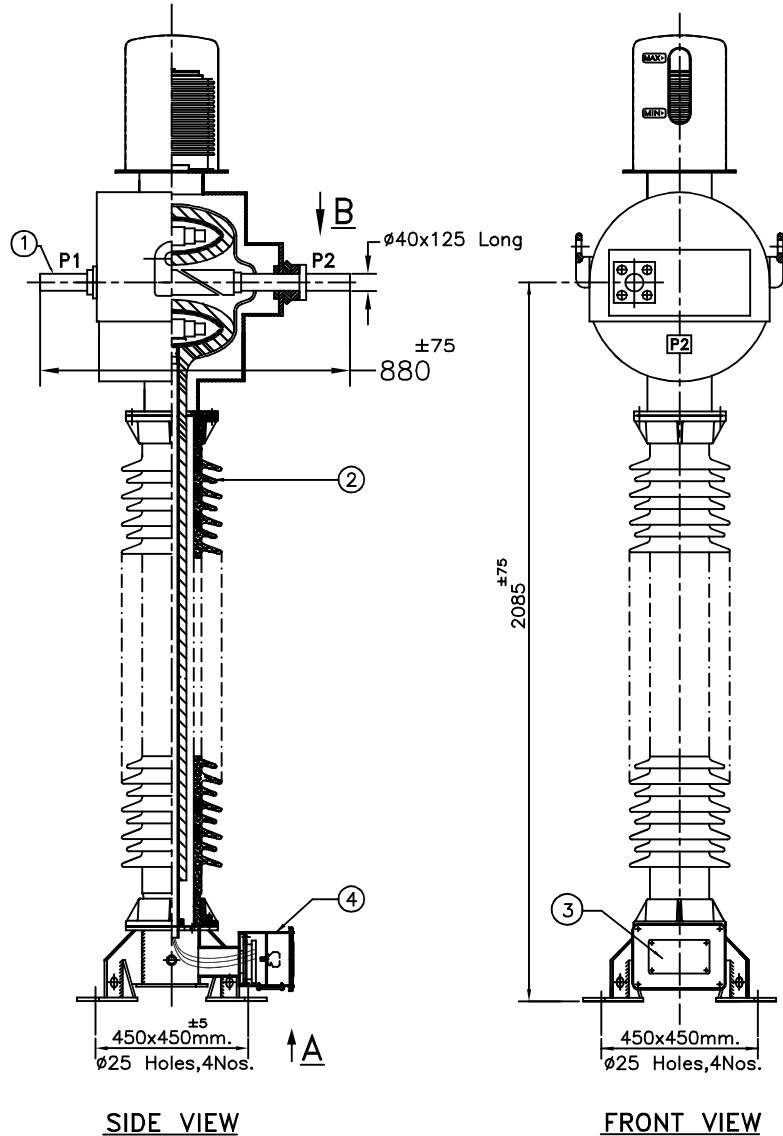

NO.	QTY.	DESCRIPTION	MATERIAL
1	2	PRIMARY TERMINAL SIZE-ø40x125L	ALUMINIUM
2	1	PORCELAIN INSULATOR (BROWN COLOUR)	PORCELAIN
3	1	RATING & SCHEMATIC DIAGRAM	145CT 300-200-1A RS
4	1	SECONDARY TERMINAL BOX	145CT 300-200-1A SB
5	1	BELLOWS	STAINLESS STEEL

Chief Engineer
Power Systems, Planning & Design
APTransco

NOTE : PLEASE REFER INSTRUCTION MANUAL FOR HANDLING & TRANSPORTATION OF CT.

R6			R4			R2			SIGN	NAME	GENERAL ARRANGEMENT DRAWINGS 145 KV CURRENT TRANSFORMER TYPE-IOSK:145/275/650				
R5			R3		R1			DRN	STJ						
								CHD	SSM						
NO	REVISION	SIGN	DATE	NO	REVISION	SIGN	DATE	NO	REVISION	SIGN	DATE	SCALE	N.T.S. DATE: 06.05.2021	ALL DIMENSIONS ARE IN mm	DRG.NO: 145CT 300-200-1A GA/RO

Drawing approval subject to valid vendor registration

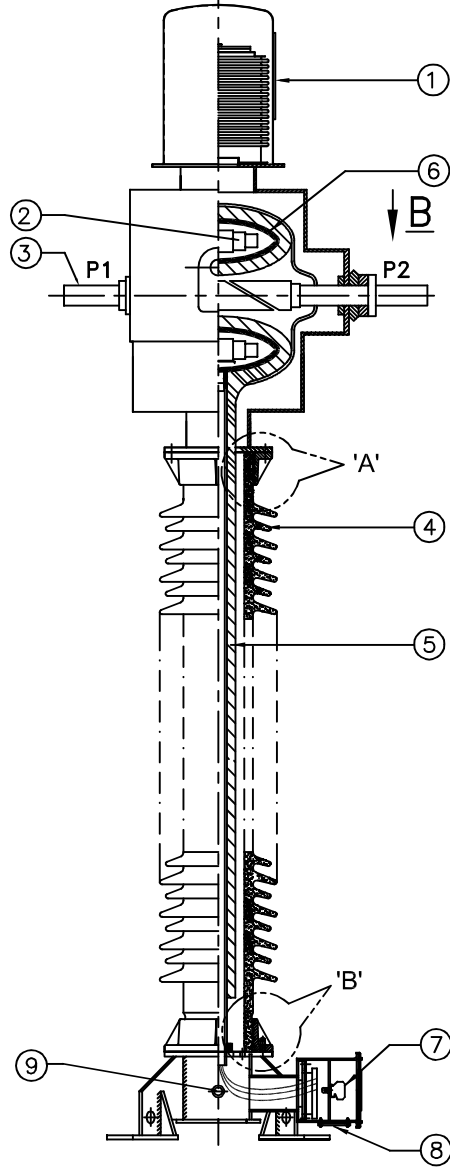

ITEM NO: 9
ASSEMBLY OF OIL SAMPLING VALVE

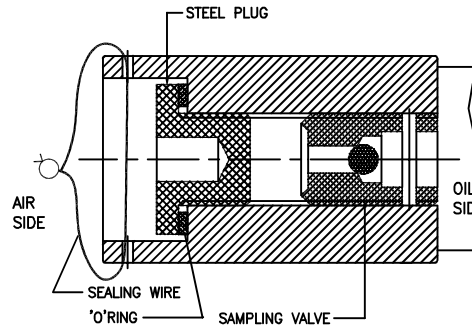

ASSEMBLY OF BELLOWS

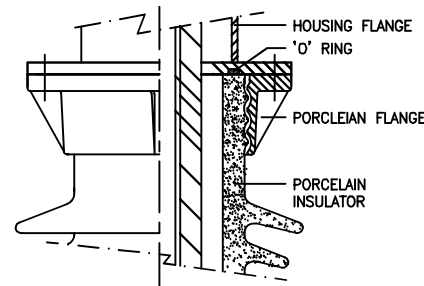
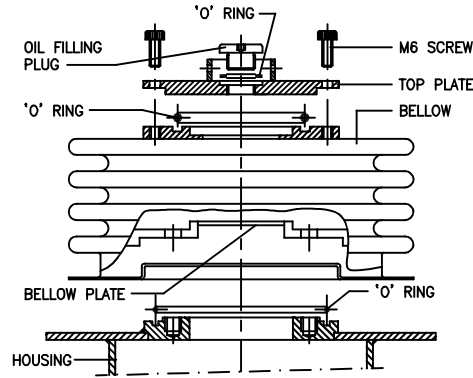

DETAILS OF 'A'

ITEM	QTY.	DESCRIPTION
1	1	OIL LEVEL INDICATOR
2	3	CORE WITH SECONDARY WINDING
3	2	PRIMARY TERMINAL(Ø40x125mm.Long.Min)
4	1	PORCELAIN INSULATOR
5	1	COND. BUSHING
6	1	METALLIC SHELL
7	11	SECONDARY TERMINALS
8	1	GLAND PLATE
9	1	OIL SAMPLING VALVE

Chief Engineer
Power Systems, Planning & Design
APTransco

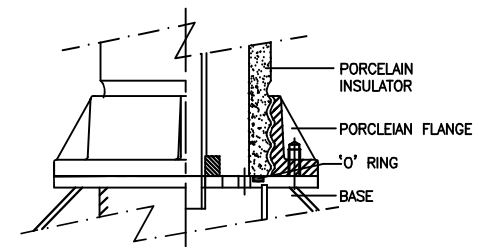

DETAILS OF 'B'

IF IN DOUBT ASK

R6			R4			R2				SIGN	NAME	SECTIONAL VIEW DRAWING FOR 145 kV CURRENT TRANSFORMER TYPE-IOSK:145/275/650	 CG Power and Industrial Solutions Limited, Aurangabad			
R5			R3			R1			DRN	STJ						
									CHD	SSM						
									APPD	SDS						
NO	REVISION	SIGN	DATE	NO	REVISION	SIGN	DATE	NO	REVISION	SIGN	DATE	SCALE	N.T.S.	DATE : 06.05.2021	ALL DIMENSIONS ARE IN mm	DRG.NO:-145CT 300-200-1A SV R0

SL.NO.	QTY	ITEM	MATERIAL	RM SIZE/SPECIFICATION
1	1	SECONDARY BOX ASSEMBLY	ALUMINIUM	DRG.NO.-480684
2	11	SEC.TERMINAL BLOCK WITH MARKER	MELAMINE	MAKE: ELMEX KBT M5-15
3	1	GLAND PLATE	ALUMINIUM	135x80 mm.
4	1	RATING & SCHEMATIC DIAGRAM	ALUMINIUM ANOD.	--

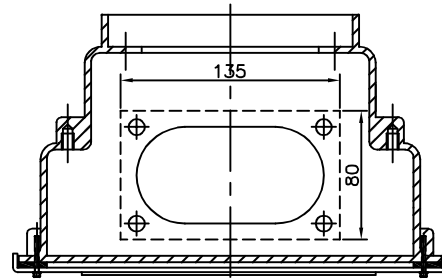

TOP VIEW (SECTION A-A)

Drawing approval subject to valid vendor registration

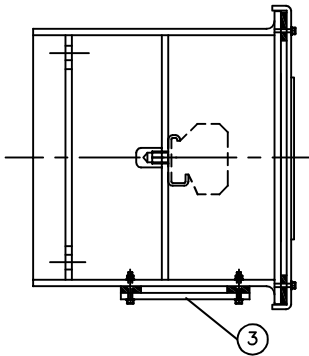

SIDE VIEW

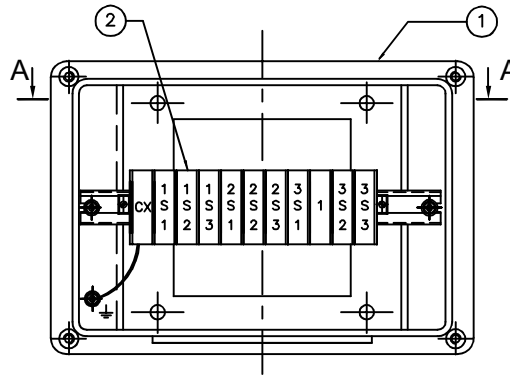

ELEVATION

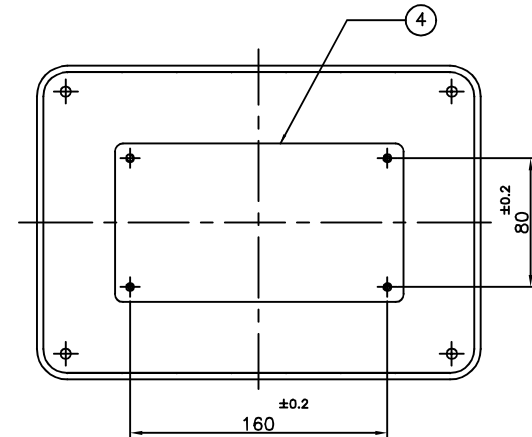

COVER

NOTES :

- 1) SECONDARY BOX ASSEMBLY TO CONFIRM IP55 AS PER IS:13947
- 2) Cx:TERMINAL FOR CAPACITANCE & TAN DELTA MESUREMENT ONLY. SHOULD BE KEPT EARTHED WHEN NOT IN USE.

Chief Engineer
Power Systems, Planning & Design
APTransco

R6			R4			R2				SIGN	NAME	SECONDARY BOX ASSEMBLY FOR 145 kV CURRENT TRANSFORMER TYPE-IOSK:145/275/650	 CG Power and Industrial Solutions Limited, Aurangabad			
R5			R3		R1				DRN	STJ						
NO	REVISION	SIGN	DATE	NO	REVISION	SIGN	DATE	NO	REVISION	SIGN	DATE			SCALE	N.T.S.	DATE: 06.05.2021

IF IN DOUBT ASK

CG Power and Industrial Solutions Limited
Vacuum Interrupters and Instrument Transformers Division: Power Systems
 D-2, MIDC, Waluj, Aurangabad 431 136, Maharashtra, India
 T. +91 240 255 8000 F. +91 240 255 4697



Page 1 of 2

**GUARANTEED TECHNICAL PARTICULARS FOR
CURRENT TRANSFORMERS**

REF.	145 KV CT	300-200/1-1-1A	, Normal Creepage	Revision:	R0
------	------------------	-----------------------	--------------------------	-----------	-----------

Sr#	Particulars	Unit	Values
1	Type/ Installation		Single Phase, Oil impregnated, Hermetically sealed, Outdoor Current Transformer. LIVE Tank Type
2	Manufacturer's Name and Country of Manufacture		CG Power and Industrial Solutions Limited Aurangabad, India
3	Manufacturers Type designation		IOSK:145/275/650
4	Highest System Voltage (Phase to phase)	kV	145
5	Type of insulation used		Class A (Oil Impregnated Paper)
6	Rated Frequency	Hz	50
7	Suitable for Altitude (Max)	Meter	1000
8	Conforming to Standard		IS: 16227-1&2 / IEC: 61869-1&2
9	Rated System Voltage (Phase to Earth)	kV	132/√3
10	Rated Primary Current	Amps	Refer Table on Page-2
11	Rated Secondary Current	Amps	Refer Table on Page-2
12	Details of Cores		Refer Table on Page-2
13	Rated Continuous current rating		120% of Rated Current
14	Ratio selection (taps) by		Secondary Taps Only.
15	No. of Secondary Cores		3
16	Rated Short Time withstand Current & duration	kAmps	31.5 kA for 1 Sec.
17	Dynamic peak withstand current	kA	78.75
18	One minute Power Frequency (Wet & Dry) withstand Voltage on Primary Winding	kV rms	275
19	1.2/50 micro sec. Lightning Impulse withstand Voltage	kV peak	650
20	One minute Power Frequency withstand Voltage on Secondary Winding	kV rms	3
21	Total Creepage distance	mm (mm/k)	3625 (25 mm/kV)
22	Primary Terminal material & details		Aluminium, φ 40 x 125 mm long
23	Surface Finish of MS components exposed to atmosphere		Hot Dip Galvanised.
24	Secondary Terminal Box arrangement		Single Door Box.
25	Volume of Oil	Litres	100 +/-10%
26	Total weight of equipment	kg	400 +/-10%
27	Mounting details	mm	4 Holes of Dia. 25 mm. @ 450x450 mm.
28	Material of Tank/Housing		Aluminium
29	Dielectric Dissipation Factor (Tan-Delta)		< 0.005
30	Measurement of Partial Discharge @ 1.2 UM/ √3	pC	< 5
31	Measurement of Partial Discharge @ UM	pC	< 10

Drawing approval subject to valid vendor registration

Registered Office:
 CG House, 6th Floor, Dr Annie Besant Road, Worli, Mumbai 400 030, India
 T: +91 22 2423 7777 F: +91 22 2423 7733 W: www.cgglobal.com
 Corporate Identity Number: L99999MH193/PLC002641

NOTE : DRAWING APPROVAL SUBJECT TO VALID TYPE TEST REPORTS, TO BE CHECKED DURING ACCEPTANCE TESTS.

FOR EPC CONTRACTS ONLY

Chief Engineer
 Power Systems, Planning & Design
 APTransco

REF.	145 KV CT	300-200/1-1-1A	Revision:	R0
------	-----------	----------------	-----------	----

TABLE - CORE DETAILS

CORE NO.	I	II	III			
PRIMARY CURRENT	200-300	200-300	200-300			
SEC. CURRENT (Amps)	1	1	1			
PRIMARY TERMINALS	P1 - P2	P1 - P2	P1 - P2			
SEC. TERMINALS	1S1 - 1S2 - 1S3	2S1 - 2S2 - 2S3	3S1 - 3S2 - 3S3			
ACCURACY CLASS	5P	PS	0.2S			
BURDEN (VA)	20		20			
ISF (for METERING)			≤ 5			
ALF (For	20					
KNEE POINT VOLTAGE		40I(Rct+10)				
I _{exc} (MAX), mA		30 @ V _k				

NOTE : DRAWING APPROVAL SUBJECT TO VALID TYPE TEST REPORTS, TO BE CHECKED DURING ACCEPTANCE TESTS.

- 1). Minimum 300 mm Plinth shall be maintained for Current transformers in the substation during foundation works to ensure safe live to ground clearances as per IE rules.
- 2). Since the supply of terminal connectors is not in the scope of CT Manufacturer as mentioned in the drawings, the EPC contractors shall be instructed to supply the same in line with the CT requirement and compatibility.

FOR EPC CONTRACTS ONLY

Chief Engineer
 Power Systems, Planning & Design
 APTransco