

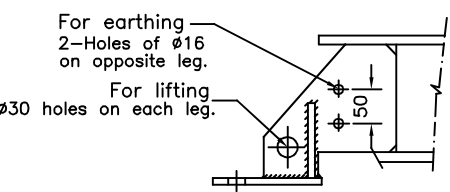

LC2 SHELL

IF IN DOUBT ASK

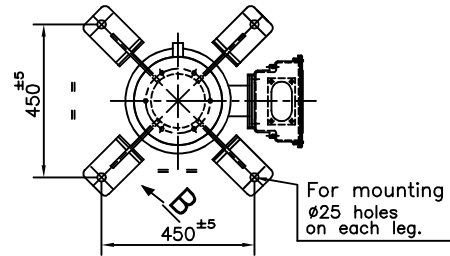
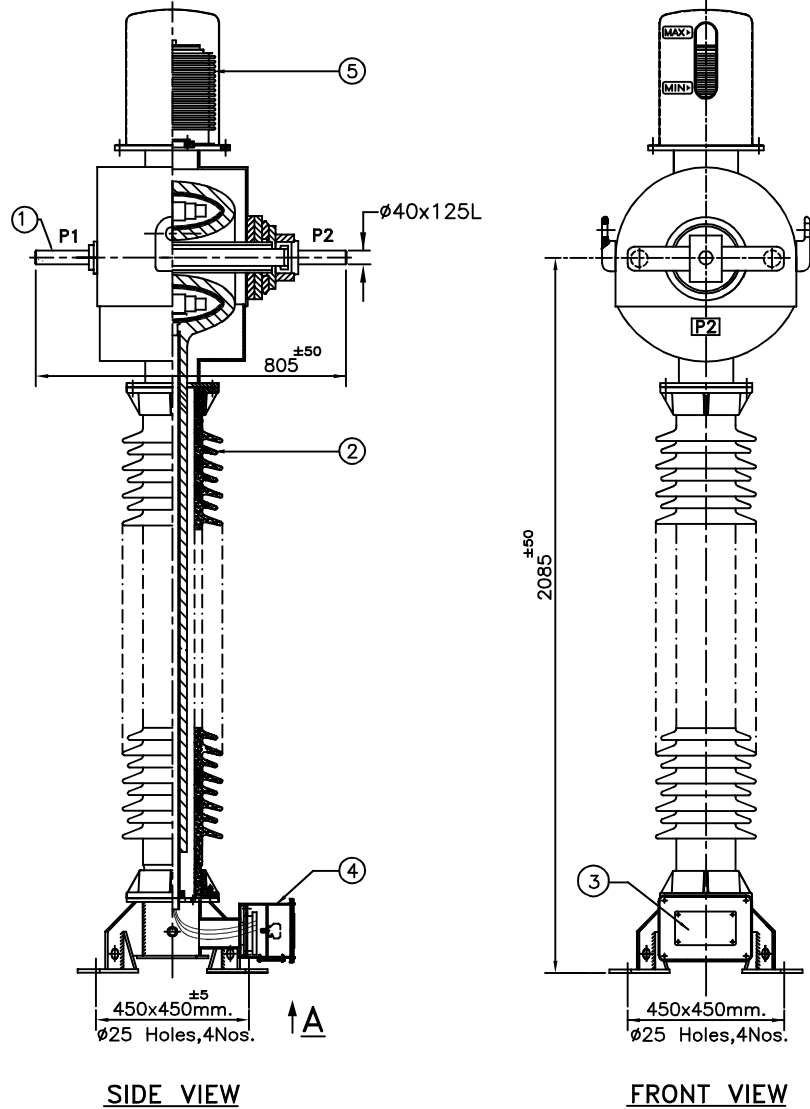

NO.	QTY.	DESCRIPTION	MATERIAL
1	2	PRIMARY TERMINAL SIZE-Ø40x125L	ALUMINIUM
2	1	PORCELAIN INSULATOR (BROWN COLOUR)	PORCELAIN
3	1	RATING & SCHEMATIC DIAGRAM	145CT HC 800-500-1A RS
4	1	SECONDARY TERMINAL BOX	145CT HC 800-500-1A SB
5	1	BELLOWS	STAINLESS STEEL

Chief Engineer  
Power Systems, Planning & Design  
APTransco

Drawing approval subject to valid vendor registration

NOTE : PLEASE REFER INSTRUCTION MANUAL FOR HANDLING & TRANSPORTATION OF CT.

R6			R4			R2			SIGN	NAME	<b>GENERAL ARRANGEMENT DRAWINGS</b> <b>145 KV CURRENT TRANSFORMER</b> <b>TYPE-IOSK:145/275/650</b>	 CG Power and Industrial Solutions Limited, Aurangabad	
R5			R3		R1			DRN	SSM				
								CHD	SSM				
NO	REVISION	SIGN/DATE	NO	REVISION	SIGN/DATE	NO	REVISION	SIGN	DATE	SCALE	N.T.S. DATE: 20.05.2021	ALL DIMENSIONS ARE IN mm	DRG.NO: 145CT HC 800-500-1A GA/R0

Drawing approval subject to valid vendor registration

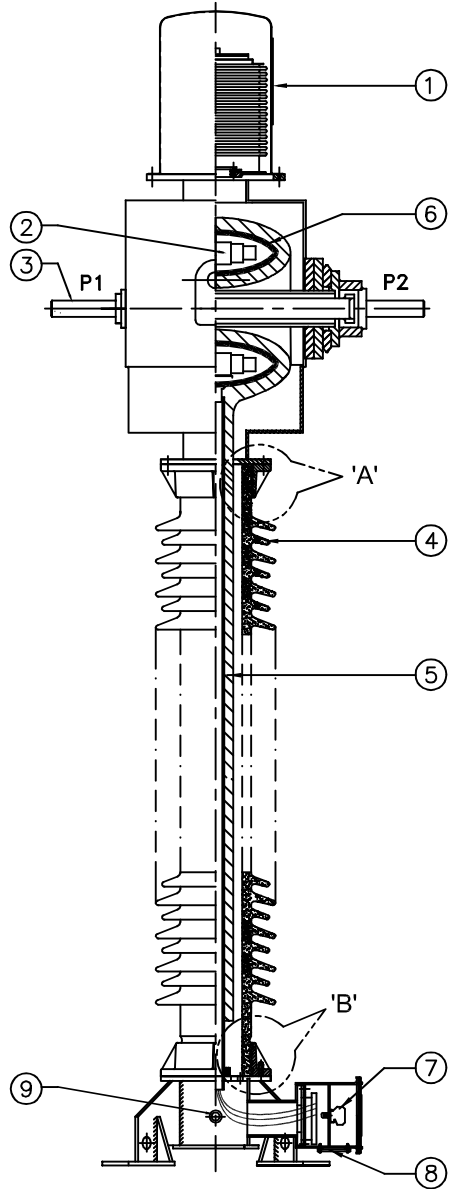

ITEM NO: 9  
ASSEMBLY OF OIL SAMPLING VALVE

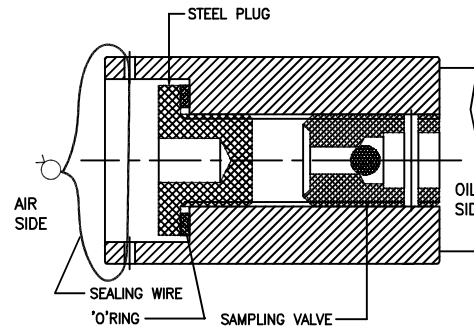

ASSEMBLY OF BELLOWS

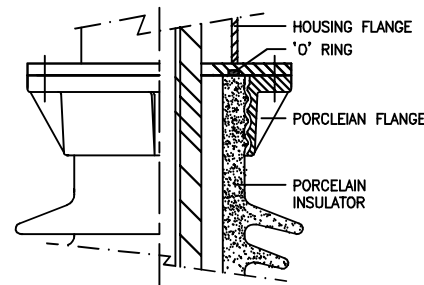
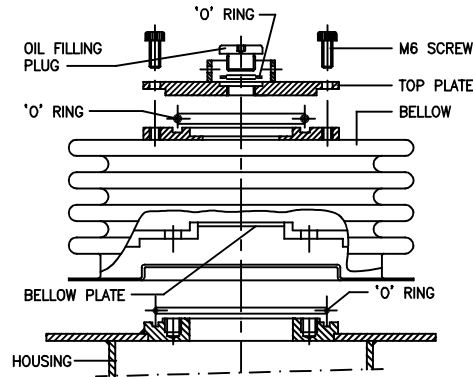

DETAILS OF 'A'

ITEM	QTY.	DESCRIPTION
1	1	OIL LEVEL INDICATOR
2	3	CORE WITH SECONDARY WINDING
3	2	PRIMARY TERMINAL(ø40x125mm.Long.Min)
4	1	PORCELAIN INSULATOR
5	1	COND. BUSHING
6	1	METALLIC SHELL
7	11	SECONDARY TERMINALS
8	1	GLAND PLATE
9	1	OIL SAMPLING VALVE

Chief Engineer  
Power Systems, Planning & Design  
APTransco

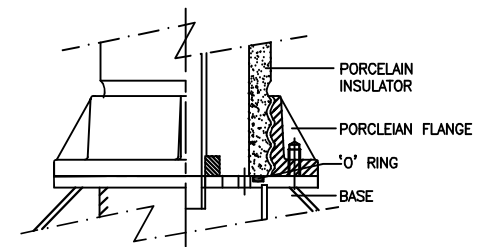

DETAILS OF 'B'

IF IN DOUBT ASK

R6			R4			R2				SIGN	NAME	SECTIONAL VIEW DRAWING FOR 145 kV CURRENT TRANSFORMER TYPE-IOSK:145/275/650	 CG Power and Industrial Solutions Limited, Aurangabad		
R5			R3			R1			DRN	SSM	ALL DIMENSIONS ARE IN mm				
								CHD	SSM						
								APPD	SDS						
NO	REVISION	SIGN	DATE	NO	REVISION	SIGN	DATE	NO	REVISION	SIGN	DATE	SCALE	N.T.S.	DATE : 20.05.2021	DRG.NO:-145CT HC 800-500-1A SV/R0

1). Minimum 300 mm Plinth shall be maintained for Current transformers in the substation during foundation works to ensure safe live to ground clearances as per IE rules.

4601576/2021/EEMRT-ENEST

2). Since the supply of terminal connectors is not in the scope of CT Manufacturer as mentioned in the drawings, the EPC contractors shall be instructed to supply the same in line with the CT requirement and compatibility.

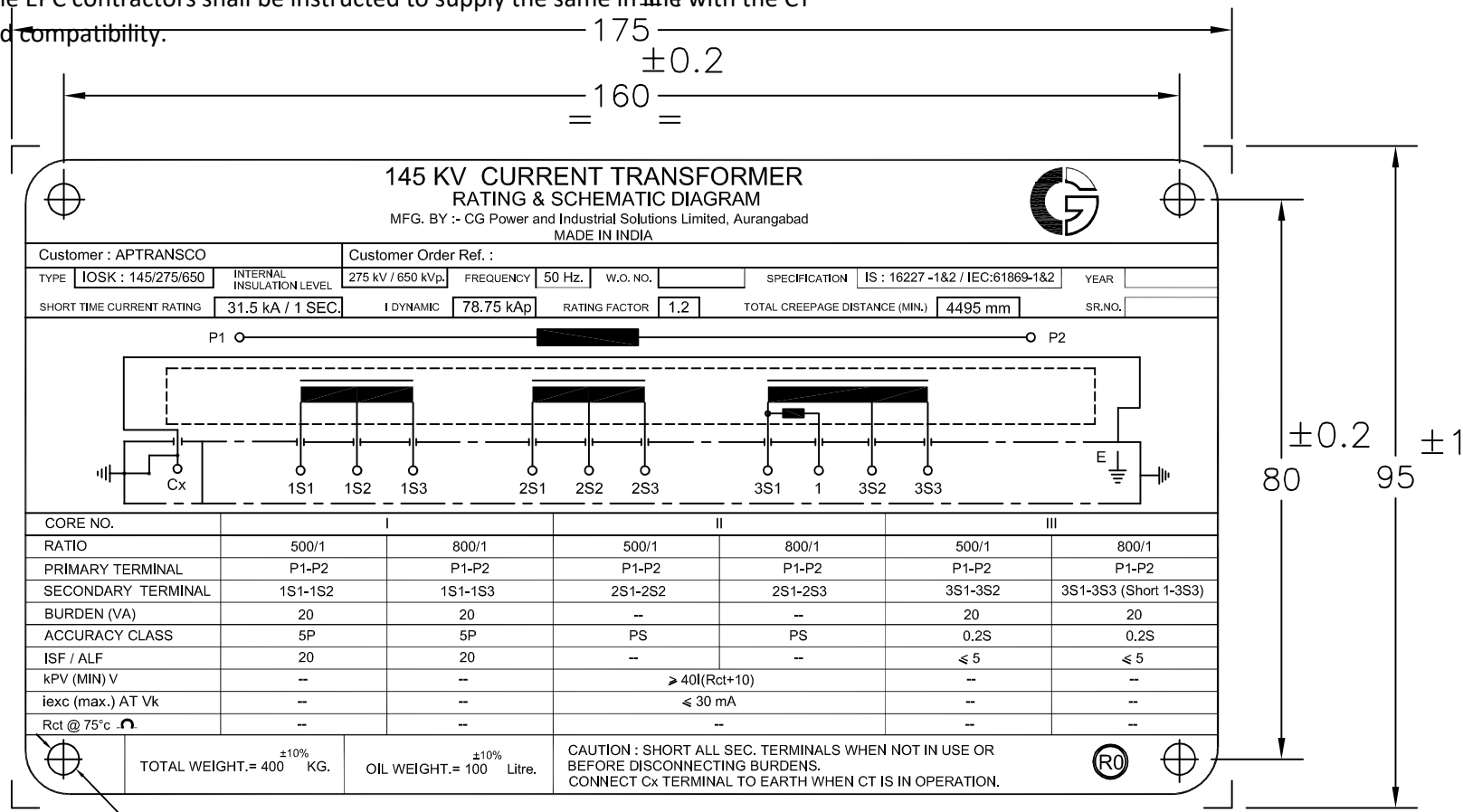

IF IN DOUBT ASK

4 HOLES OF Ø4.5 mm  
Material-Aluminium Anodised.

CT SR.NOs. :

Drawing approval subject to valid vendor registration

NOTE : DRAWING APPROVAL SUBJECT TO VALID TYPE TEST REPORTS, TO BE CHECKED DURING ACCEPTANCE TESTS.

Chief Engineer  
Power Systems, Planning & Design  
APTransco

R6				R4				R2				SIGN	NAME	<b>RATING &amp; SCHEMATIC DIAGRAM</b> <b>FOR 145 KV CURRENT TRANSFORMER</b> <b>TYPE-IOSK:145/275/650</b>		
R5				R3			R1				DRN	SSM				
											CHD	SSM				
											APPD	SDS				
NO	REVISION	SIGN	DATE	NO	REVISION	SIGN	DATE	NO	REVISION	SIGN	DATE	SCALE	N.T.S.	DATE : 20.05.2021	ALL DIMENSIONS ARE IN mm	DRG.NO:- 145CT HC 800-500-1A RS/R0

SL.NO.	QTY	ITEM	MATERIAL	RM SIZE/SPECIFICATION
1	1	SECONDARY BOX ASSEMBLY	ALUMINIUM	DRG.NO.-480684
2	11	SEC.TERMINAL BLOCK WITH MARKER	MELAMINE	MAKE: ELMEX KBT M5-15
3	1	GLAND PLATE	ALUMINIUM	135x80 mm.
4	1	RATING & SCHEMATIC DIAGRAM	ALUMINIUM ANOD.	--

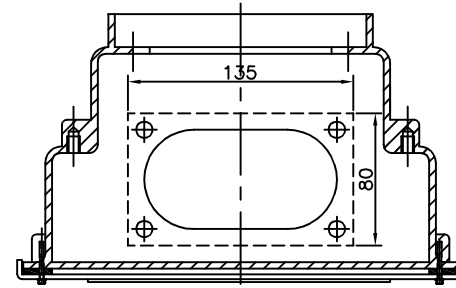

TOP VIEW (SECTION A-A)

Drawing approval subject to valid vendor registration

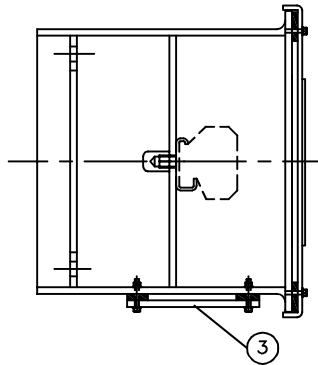

SIDE VIEW

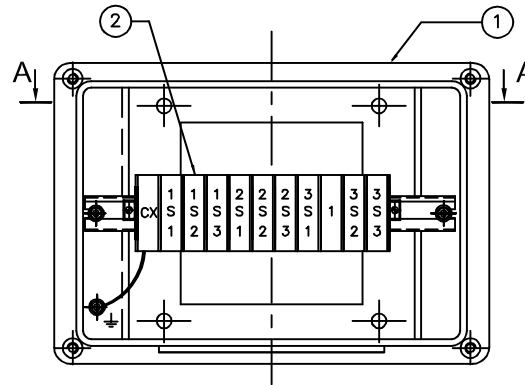

ELEVATION

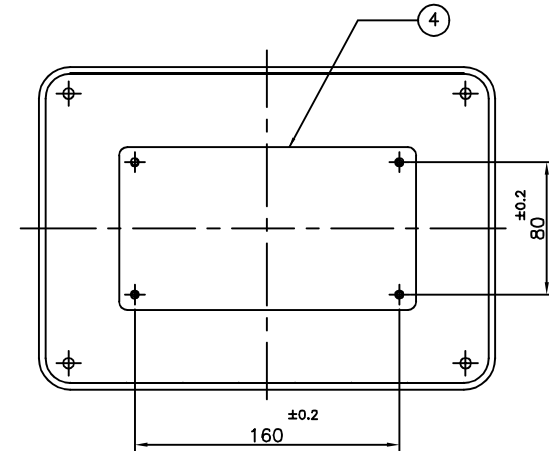

COVER

NOTES :

- 1) SECONDARY BOX ASSEMBLY TO CONFIRM IP55 AS PER IS:13947
- 2) Cx:TERMINAL FOR CAPACITANCE & TAN DELTA MESUREMENT ONLY. SHOULD BE KEPT EARTHED WHEN NOT IN USE.

Chief Engineer  
Power Systems, Planning & Design  
APTransco

R6			R4			R2			SIGN	NAME	SECONDARY BOX ASSEMBLY FOR 145 kV CURRENT TRANSFORMER TYPE-IOSK:145/275/650	 CG Power and Industrial Solutions Limited, Aurangabad				
R5			R3			R1		DRN	SSM							
								CHD	SSM							
								APPD	SDS							
NO	REVISION	SIGN	DATE	NO	REVISION	SIGN	DATE	NO	REVISION	SIGN	DATE	SCALE	N.T.S.	DATE: 20.05.2021	ALL DIMENSIONS ARE IN mm	DRG.NO: 145CT HC 800-500-1A SB/R0

IF IN DOUBT ASK

**CG Power and Industrial Solutions Limited**  
**Vacuum Interrupters and Instrument Transformers Division: Power Systems**  
 D-2, MIDC, Waluj, Aurangabad 431 136, Maharashtra, India  
 T: +91 240 255 8000 F: +91 240 255 4697



Page 1 of 2

**GUARANTEED TECHNICAL PARTICULARS FOR  
CURRENT TRANSFORMERS**

REF.	145 KV CT	800-500/1-1-1A	, High Creepage.	Revision:	R0
------	-----------	----------------	------------------	-----------	----

Sr#	Particulars	Unit	Values
1	Type/ Installation		Single Phase, Oil impregnated, Hermetically sealed, Outdoor Current Transformer. LIVE Tank Type
2	Manufacturer's Name and Country of Manufacture		CG Power and Industrial Solutions Limited Aurangabad, India
3	Manufacturers Type designation		IOSK:145/275/650
4	Highest System Voltage (Phase to phase)	kV	<b>145</b>
5	Type of insulation used		Class A (Oil Impregnated Paper)
6	Rated Frequency	Hz	50
7	Suitable for Altitude (Max)	Meters	1000
8	Conforming to Standard		IS: 16227-1&2 / IEC: 61869-1&2
9	Rated System Voltage (Phase to Earth)	kV	132/√3
10	Rated Primary Current	Amps	Refer Table on Page-2
11	Rated Secondary Current	Amps	Refer Table on Page-2
12	Details of Cores		Refer Table on Page-2
13	Rated Continuous current rating		120% of Rated Current
14	Ratio selection (taps) by		Secondary Taps Only.
15	No. of Secondary Cores		<b>3</b>
16	Rated Short Time withstand Current & duration	kAmps/s ecs	31.5 kA for 1 Sec.
17	Dynamic peak withstand current	kA peak	78.75
18	One minute Power Frequency (Wet & Dry) withstand Voltage on Primary Winding	kV rms	275
19	1.2/50 micro sec. Lightning Impulse withstand Voltage	kV peak	650
20	One minute Power Frequency withstand Voltage on Secondary Winding	kV rms	3
21	Total Creepage distance	mm (mm/kV)	4495 (31 mm/kV)
22	Primary Terminal material & details		Aluminium, φ 40 x 125 mm long
23	Surface Finish of MS components exposed to atmosphere		Hot Dip Galvanised.
24	Secondary Terminal Box arrangement		Single Door Box.
25	Volume of Oil	Litres	100 +/-10%
26	Total weight of equipment	kg	400 +/-10%
27	Mounting details	mm	4 Holes of Dia. 25 mm. @ 450x450 mm.
28	Material of Tank/Housing		Aluminium
29	Dielectric Dissipation Factor ( Tan-Delta )		< 0.005
30	Measurement of Partial Discharge @ 1.2 UM/ √3	pC	< 5
31	Measurement of Partial Discharge @ UM	pC	< 10

145LTL2ALFF

Registered Office:  
 CG House, 6th Floor, Dr Annie Besant Road, Worli, Mumbai 400 030, India  
 T: +91 22 2423 7777 F: +91 22 2423 7733 W: www.cgglobal.com  
 Corporate Identity Number: L99999MH1937PLC002641

Chief Engineer  
 Power Systems, Planning & Design  
 APTransco

**CG Power and Industrial Solutions Limited**  
**Vacuum Interrupters and Instrument Transformers Division: Power Systems**  
 D-2, MIDC, Waluj, Aurangabad 431 136, Maharashtra, India  
 T. +91 240 255 8000 F. +91 240 255 4697



Page 2 of 2

REF.	145 KV CT	800-500/1-1-1A	Revision:	R0
------	-----------	----------------	-----------	----

TABLE - CORE DETAILS

CORE NO.	I	II	III			
PRIMARY CURRENT	500-800	500-800	500-800			
SEC. CURRENT (Amps)	1	1	1			
PRIMARY TERMINALS	P1 - P2	P1 - P2	P1 - P2			
SEC. TERMINALS	1S1 - 1S2 - 1S3	2S1 - 2S2 - 2S3	3S1 - 3S2 - 3S3			
ACCURACY CLASS	5P	PS	0.2S			
BURDEN (VA)	20		20			
ISF (for METERING)			≤ 5			
ALF (For PROTECTION)	20					
KNEE POINT VOLTAGE		40I(Rct+10)				
I <sub>exc</sub> (MAX), mA		30 @ V <sub>k</sub>				

**NOTE : DRAWING APPROVAL SUBJECT TO VALID TYPE TEST REPORTS, TO BE CHECKED DURING ACCEPTANCE TESTS.**

- 1). Minimum 300 mm Plinth shall be maintained for Current transformers in the substation during foundation works to ensure safe live to ground clearances as per IE rules.
- 2). Since the supply of terminal connectors is not in the scope of CT Manufacturer as mentioned in the drawings, the EPC contractors shall be instructed to supply the same in line with the CT requirement and compatibility.

**FOR EPC CONTRACTS ONLY**

Chief Engineer  
 Power Systems, Planning & Design  
 APTransco

Drawing approval subject to valid vendor registration