

M.S. O' RING  
 Drawing approval subject to valid vendor registration

S.No.	DESCRIPTION	QTY	MATL
1	H.T TERMINAL Ø30 Nickel Plated Copper ...		
2	BELLOW	1	S.S
3	PRESSURE RELEASE DEVICE	1	AL.+BAKELITE
4	BELLOW DOME	1	M.S/AL.
5	OIL LEVEL INDICATOR	1	AL/BRASS
6	OIL EXPANSION CHAMBER	1	M.S
7	BUSHING FLANGE (CEMENTED)	2	GI/CI
8	BUSHING	1	PORCELAIN
9	LIFTING LUG	4	M.S
10	NAME AND RATING PLATE	1	AL. ANODIZED
11	TANK WITH COVER	1	M.S
12	OIL DRAIN PLUG	1	M.S
13	EARTHING FLAT 80x50x8mm THICK.	2	M.S
14	SEC.& EARTHING TERMINAL BOX	1	M.S
15	MOUNTING CHANNEL 75x40	4	M.S
16	BUSHING FLAT GASKET	2	N.B.R

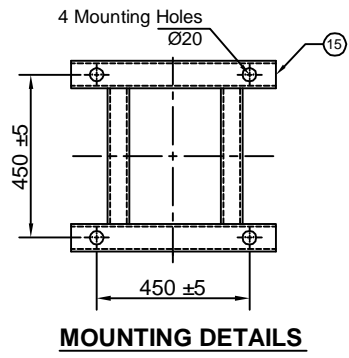
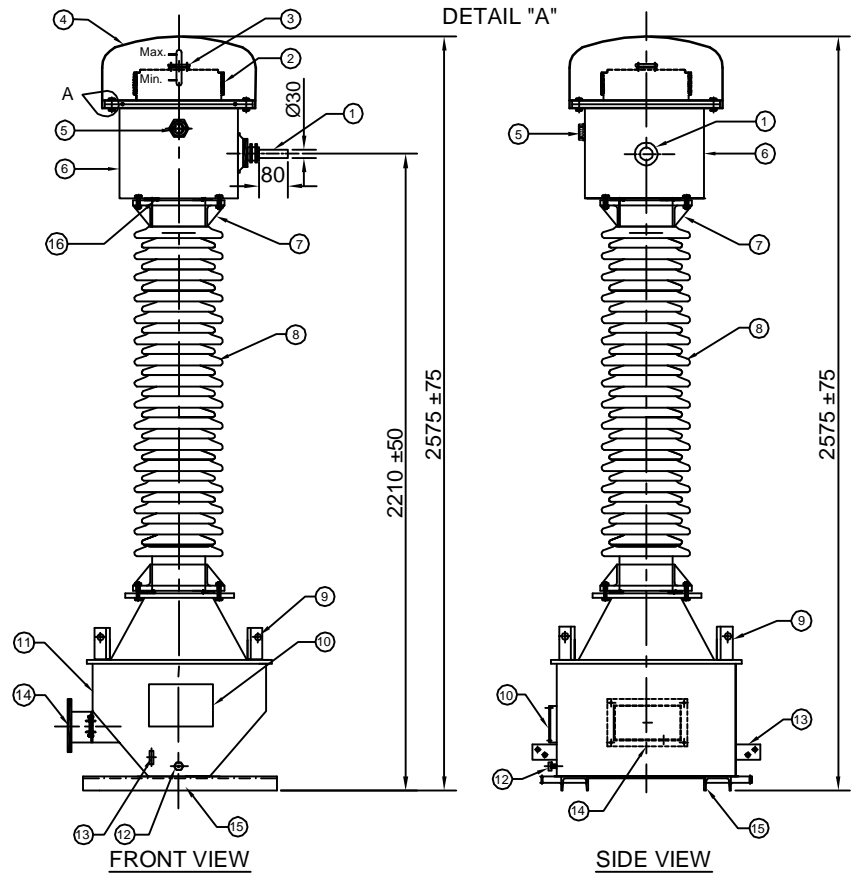

**MOUNTING DETAILS**

**NOTES :**

1. ALL FERROUS PARTS EXPOSED TO THE ATMOSPHERE SHALL BE PAINTED WITH P.U PAINT SHADE 631 OF IS: 5.
2. MAKE OF BUSHING: IEC/MODERN/BHEL/ABIL/CJI
3. TOTAL CREEPAGE DISTANCE :- 3625 mm (Min.)
4. QUANTITY OF OIL :- 125 LITRES APPROX.
5. TOTAL WEIGHT OF PT : 500 KGS APPROX.
6. ALL HARDWARE SHALL BE HOT DIP GALVANIZED.
7. TRANSFORMER OIL AS PER IEC : 60296.
8. ALL GASKETS SHALL BE FIXED IN PROPERLY MACHINED GROOVES.
9. ALL GASKETS SHALL BE MADE OF NITRILE BUTYL RUBBER.

**NOTE : DRAWING APPROVAL SUBJECT TO VALID TYPE TEST REPORTS, TO BE CHECKED DURING ACCEPTANCE TESTS.**

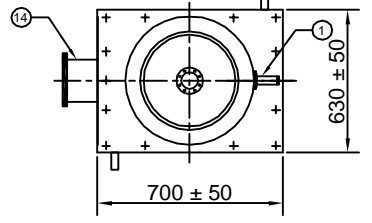

Chief Engineer  
 Power Systems, Planning & Design  
 APTransco

REV.	REVISION DESCRIPTION	DATED INITIALS
RO	FOR APPROVAL	06.01.2021

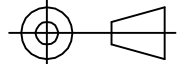
CLIENT : TRANSMISSION CORPORATION OF ANDHRA PRADESH LIMITED				PROJECT NAME : AS APPLICABLE	
UNLESS OTHERWISE SPECIFIED  1. ALL DIMENSIONS ARE IN mm. 2. TOLERANCE WHEREVER NOT INDICATED ±5%	DGN.	06.01.2021	NAME	SPS	AS ABOVE
	DRN.	06.01.2021	NAME	AKASH	
	CHD.	06.01.2021	NAME	BLS	
	SCALE:	N.T.S			
SHEET No.			TITLE :		
1 OF 7			GENERAL ARRANGEMENT DRAWING FOR 132kV POTENTIAL TRANSFORMER		
				 MEHRU ELECTRICAL & MECHANICAL ENGINEERS (P) LTD. 	
				DRG.NO ME-132PT-GA-01	

# MEHRU VOLTAGE TRANSFORMER

SR.No.		REF.STD.	IS: 16227
TYPE	Outdoor Oil Cooled	RATIO	132 kV / $\sqrt{3}$
Highest System Voltage	145 kV		$110V/\sqrt{3}$ - $110V/\sqrt{3}$
PHASE	Single	BURDEN	150 VA - 50 VA
Insulation level	275/650 kV	CLASS	0.2 - 3P
Thermal Burden	200 VA	Simultaneous Burden	150 VA - 50 VA
Frequency	50 Hz	Type	Earthed
Voltage Factor	1.2	TIME CONT. &	1.5
		TIME FOR	30 Sec
		YEAR OF MFG.	2021

TOTAL WEIGHT OF VT : 500 KGS APPROX.  
 QUANTITY OF OIL :-125 LITRES APPROX. TOTAL CREEPAGE DISTANCE :- 3625 mm (Min.)

MADE IN INDIA BY  
**MEHRU ELECTRICAL AND MECHANICAL ENGINEERS (P) LTD.**  
 SP-2/180, RIICO INDUSTRIAL AREA KHARANI EXT. BHIWADI-301019, RAJ. (INDIA)

## SUITABLE FOR HOT LINE WASHING CONNECTION DIAGRAM

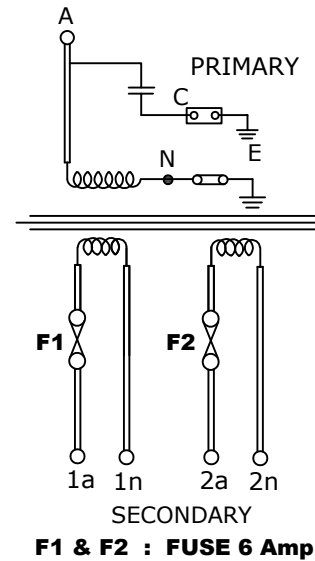

**F1 & F2 : FUSE 6 Amp.**

### CAUTION :

- KEEP OPEN ALL SECONDARIES TERMINALS ARE NOT IN USE.
- ALWAYS KEEP NEUTRAL TERMINAL 'N' AND TAN DELTA TESTING TERMINAL 'C' SHORTED TO EARTH DURING OPERATION
- DO NOT REMOVE EARTH LINK WHEN IN OPERATION.

115 ±10

195 ±15

### NOTES:-

- THICKNESS OF RATING PLATE 1.2 mm
- MATERIAL OF NAME PLATE SHALL BE AL. ANODIZED.
- SERIAL NUMBER SHALL BE ENGRAVING BEFORE THE DISPATCH.

Drawing approval subject to valid vendor registration

4613541/2021/EEMRT-ENE51

Chief Engineer  
 Power Systems, Planning & Design  
 APTransco

REV.	REVISION DESCRIPTION	DATED INITIALS
R0	FOR APPROVAL	06.01.2021

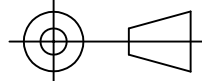
CLIENT : TRANSMISSION CORPORATION OF ANDHRA PRADESH LIMITED PROJECT NAME : AS APPLICABLE			
UNLESS OTHERWISE SPECIFIED	DATE	NAME	MATERIAL
1. ALL DIMENSIONS ARE IN mm.	DGN. 06.01.2021	SPS	AL.ANODIZED
2. TOLERANCE WHEREVER NOT INDICATED ±5%	DRN. 06.01.2021	AKASH	
	CHD. 06.01.2021	BLS	
SCALE:	N.T.S		
TITLE : NAME PLATE DRAWING FOR 132KV POTENTIAL TRANSFORMER			
SHEET No. 3 OF 7			 <b>MEHRU ELECTRICAL &amp; MECHANICAL ENGINEERS (P) LTD.</b>  DRG.NO ME-132PT-NP-01

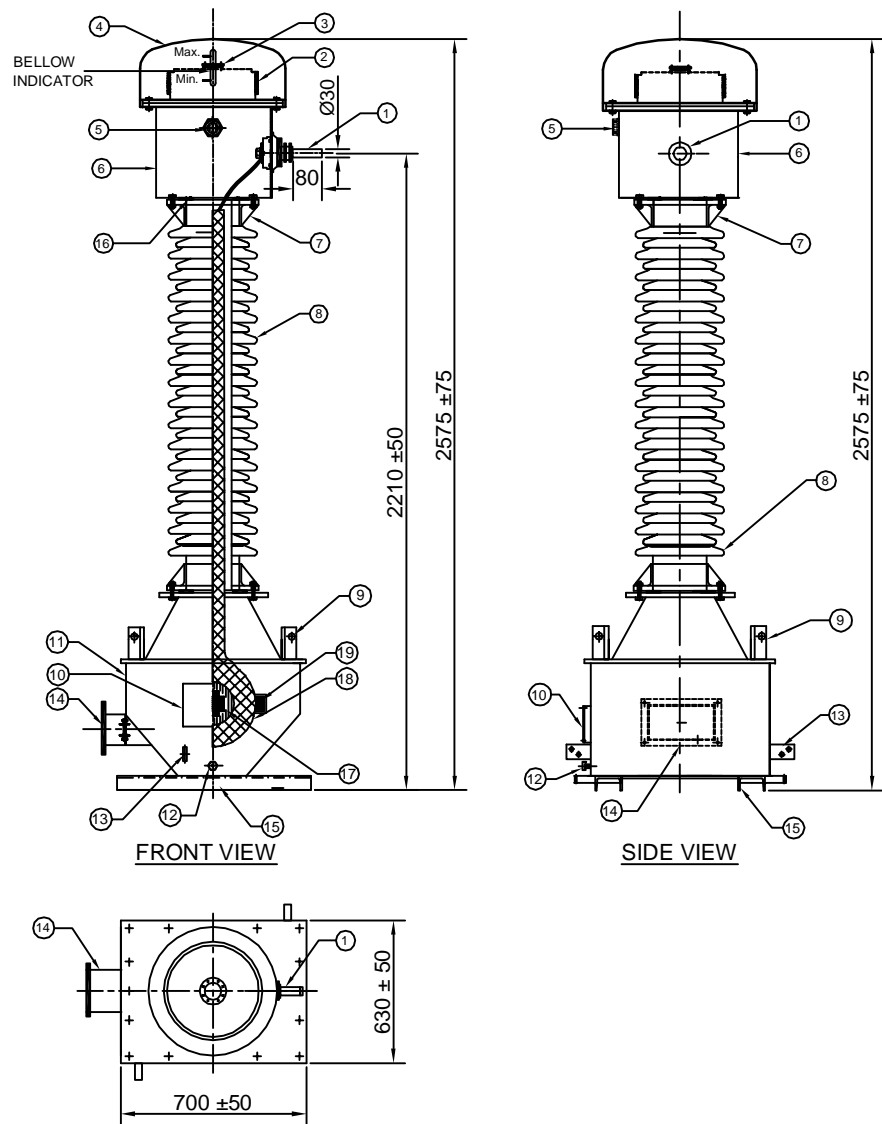

Chief Engineer  
Power Systems, Planning & Design  
APTransco

REV.	REVISION DESCRIPTION	DATED INITIALS
R0	FOR APPROVAL	06.01.2021

CLIENT : TRANSMISSION CORPORATION OF ANDHRA PRADESH LIMITED PROJECT NAME : AS APPLICABLE			
UNLESS OTHERWISE SPECIFIED	DATE	NAME	MATERIAL
1. ALL DIMENSIONS ARE IN mm. 2. TOLERANCE WHEREVER NOT INDICATED ±5%	DGN.	06.01.2021	SPS
	DRN.	06.01.2021	AKASH
	CHD.	06.01.2021	BLS
	SCALE:	N.T.S	
TITLE :			<b>MEHRU</b> MEHRU ELECTRICAL & MECHANICAL ENGINEERS (P) LTD.
SECTIONAL ARRANGEMENT DRAWING FOR 132kV POTENTIAL TRANSFORMER			
SHEET No. 2 OF 7			DRG.NO ME-132PT-SE-01

S.No.	DESCRIPTION	QTY	MATL
1	H.T TERMINAL Ø30		Nickel Plated Copper
2	BELLOW	1	S.S
3	PRESSURE RELEASE DEVICE	1	AL.+BAKELITE
4	BELLOW DOME	1	M.S/AL.
5	OIL LEVEL INDICATOR	1	AL./BRASS
6	OIL EXPANSION CHAMBER	1	M.S
7	BUSHING FLANGE (CEMENTED)	2	GI/CI
8	BUSHING	1	PORCELAIN
9	LIFTING LUG	4	M.S
10	NAME AND RATING PLATE	1	AL. ANODIZED
11	TANK WITH COVER	1	M.S
12	OIL DRAIN PLUG	1	M.S
13	EARTHING FLAT 80x50x8mm THICK.	2	M.S
14	SEC.& EARTHING TERMINAL BOX	1	M.S
15	MOUNTING CHANNEL 75x40	4	M.S
16	BUSHING FLAT GASKET	2	N.B.R
17	LT COIL WITH PAPER INSULATION	1	COPPER
18	HT COIL WITH PAPER INSULATION	1	COPPER
19	STACK LAMINATION		CRGO

NOTES :

- ALL FERROUS PARTS EXPOSED TO THE ATMOSPHERE SHALL BE PAINTED WITH P.U PAINT SHADE 631 OF IS: 5.
- MAKE OF BUSHING: IEC/MODERN/BHEL/ABIL/CJI
- TOTAL CREEPAGE DISTANCE :- 3625 mm (Min.)
- QUANTITY OF OIL :-125 LITRES APPROX.
- TOTAL WEIGHT OF PT : 500 KGS APPROX.
- ALL HARDWARE SHALL BE HOT DIP GALVANIZED.
- TRANSFORMER OIL AS PER IEC : 60296.
- ALL GASKETS SHALL BE FIXED IN PROPERLY MACHINED GROOVES.
- ALL GASKETS SHALL BE MADE OF NITRILE BUTYL RUBBER.

Drawing approval subject to valid vendor registration

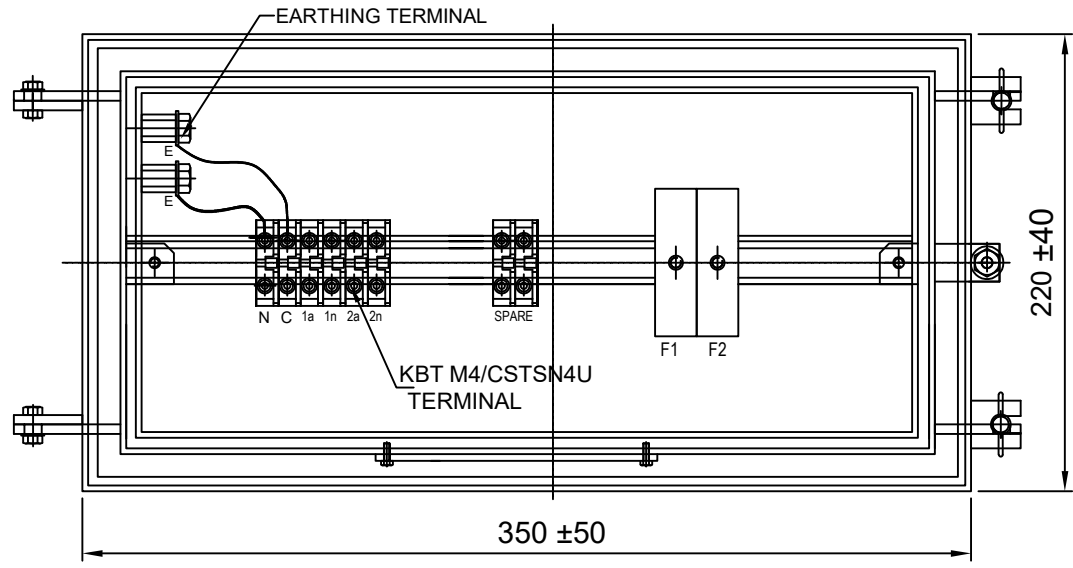

**FRONT VIEW**

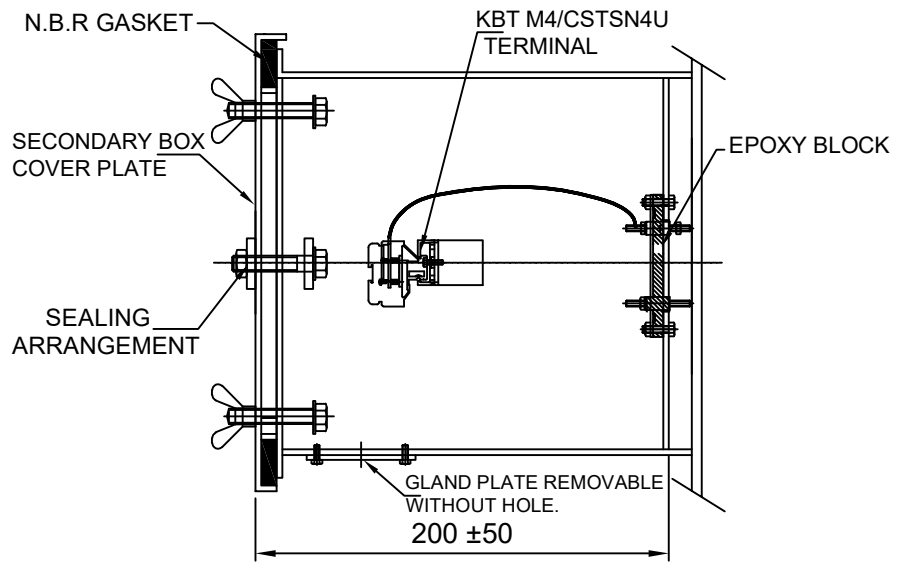

**SIDE VIEW**

'N' : NEUTRAL TERMINAL  
 'C': TAN DELTA TESTING TERMINAL  
**F1 & F2 : FUSE 6 Amp.**

**NOTES:-**

1. SECONDARY TERMINAL BOX SHALL BE PROVIDED REMOVABLE GLAND PLATE WITHOUT HOLE.
2. SECONDARY TERMINAL BOX SHALL BE PROVIDED WITH COVER.
3. M.S SHEET THICKNESS FOR TERMINAL BOX 3.0mm. & FOR COVER 2.0mm.
4. MATERIAL OF GASKET: NITRILE BUTYL RUBBER GASKET.
5. DEGREE OF PROTECTION : IP 55
6. 20% SPARE TERMINAL SHALL BE PROVIDED.

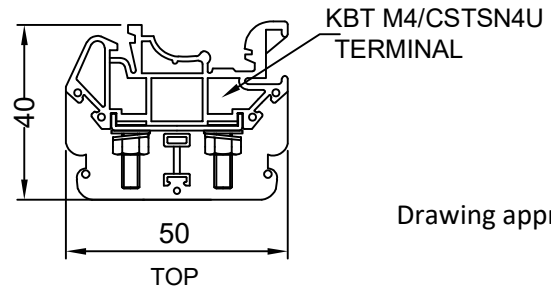

TOP

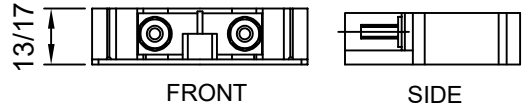

FRONT

SIDE

MATERIAL: POLYAMIDE  
 MAKE: ELMEX/CONNECTWELL

**TERMINAL (DETAIL)**

Drawing approval subject to valid vendor registration

Chief Engineer  
 Power Systems, Planning & Design  
 APTransco

4613541/2021/EEMRT-ENE51

CLIENT : TRANSMISSION CORPORATION OF ANDHRA PRADESH LIMITED				<div style="border: 1px solid black; padding: 2px; display: inline-block;">MEHRU</div> MEHRU ELECTRICAL & MECHANICAL ENGINEERS (P) LTD.
PROJECT NAME : AS APPLICABLE				
UNLESS OTHERWISE SPECIFIED	DATE	NAME	MATERIAL	
1. ALL DIMENSIONS ARE IN mm.	DGN. 06.01.2021	SPS	M.S	
2. TOLERANCE WHEREVER NOT INDICATED ±5%	DRN. 06.01.2021	AKASH		
	CHD. 06.01.2021	BLS		
SCALE:	N.T.S			
TITLE :				
SECONDARY TERMINAL BOX DRAWING FOR 132KV POTENTIAL TRANSFORMER				
SHEET No. 4 OF 7				DRG.NO ME-132PT-STB-01

REV.	REVISION DESCRIPTION	DATED INITIALS
R0	FOR APPROVAL	06.01.2021

NOTE : DRAWING APPROVAL SUBJECT TO VALID TYPE TEST REPORTS, TO BE CHECKED DURING ACCEPTANCE TESTS.

Since the supply of terminal connectors is not in the scope of manufacturer as mentioned in the drawings, the EPC contractors shall be instructed to supply the same in line with CT/IVT/CVT requirement and compatibility.

## FOR EPC CONTRACTS ONLY

Drawing approval subject to valid vendor registration

Chief Engineer  
Power Systems, Planning & Design  
APTransco

GUARANTEE TECHNICAL PARTICULARS OF 132KV POTENTIAL TRANSFORMER		
S.NO	DESCRIPTION	132KV
1	Type	Mehru Electrical & Mechanical Engineers (P) Ltd, Bhiwadi, (Raj), India
2	Manufacturer's type designation	Outdoor, Oil Cooled, Electromagnetic Type, Voltage Transformer
3	Mounting of tank (bottom)	Bottom
4	System rated voltage/highest voltage (kv)	132/145
5	Rated primary voltage (kv)	132 KV/3
6	Secondary winding details	
	(a)No.ofsecondary windings	2
	(b)Rated secondary voltage(V)	110V/3 - 110V/3
	©Rated burden VA (simultaneous)	150 VA - 50 VA
	(d)Class of accuracy	Wdg 1: - 0.2, Wdg 2: 3P
7	Maximum ratio error with % rated burden and 5 % normal primary voltage	In limits as per IS 16227
8	Maximum phase angle error with % rated burden and 5 % normal primary voltage	In limits as per IS 16227
9	Temperature rise at 1.1 times rated voltage with rated burden deg.C	50deg C
10	Rated voltage factor and time	1.2 continuous & 1.5 for 30 seconds
11	Temperature rise for item-10 above deg.C	
12	Impulse withstand test voltage (kv) peak	650
13	One minute power frequency withstand test voltage on secondary (kv rms)	3
14	One minute power frequency withstand test voltage on primary (kv rms)	275
15	Total creepage distance of the bushing mm	25 mm/kV i.e. 3625 mm
16	Grade of oil	EHV IS 335/IEC 60296
17	Quantity of insulating oil (Litres)	125Ltr Approx
18	Weight of oil (kg)	100 kgs Approx
19	Total weight including oil (kg)	500KG Approx
20	Whether sealed (if so type of sealing)	Yes, SS BELLOW
21	Over all dimensions	
	Height (mm)	2575±75mm
	Length (mm)	450±5mm
	Breadth (mm)	450±5mm
22	Weight of Steel	115 kgs (Approx.)
	Weight of copper	11 kgs (Approx.)
a)	Radio interference voltage	As per IS 16227 Clause 6.11.2 <2500uV
b)	Partial discharge level	<10 pC at Um & <5 pc at 1.2Um/3
	Tan delta	<0.005