

Tandem Pipe size of Isolator / E.S./Aux Tandem Pipe Shall be Minimum 32 mm NB

- PART LIST:**
1. FIXED CONTACT ASSEMBLY
 2. MOVING CONTACT ASSEMBLY
 3. INSULATOR STACK (NOT IN OUR SCOPE OF SUPPLY)
 4. TANDEM PIPE CLASS " B " G.I. PIPE
 5. ELEVATOR CHANNEL (10 mm THK)
 6. BASE CHANNEL (125 x 65 x 5 mm THICK CHANNEL)
 7. ROTATING SHAFT WITH LEVER ARM & CLAMP (M.S. HDG)
 8. UNIVERSAL JOINT ARRANGEMENT
 9. DOWN OPERATING PIPE (50 NB, CLASS " B " G.I. PIPE)
 10. OPERATING MECHANISM FOR MAIN SWITCH (MANUAL)
 11. SUPPORTING STRUCTURE (NOT IN OUR SCOPE OF SUPPLY)
 12. PROVISION FOR PADLOCK
 13. E.S. FIXED CONTACT ASSEMBLY
 14. E.S. MOVING CONTACT ASSEMBLY
 15. E.S. TANDEM PIPE CLASS " B " G.I. PIPE
 16. TOP OPERATING MECHANISM FOR E.S.
 17. E.S. DOWN OPERATING PIPE (50 NB, CLASS " B " G.I. PIPE)
 18. OPERATING MECHANISM FOR E.S. (MANUAL)
 19. MECHANICAL INTERLOCK BETWEEN M.S. & E.S.
 20. AUX. TANDEM PIPE CLASS " B " G.I. PIPE
 21. COUNTER WEIGHT

- REFERENCE DRAWINGS:**
- FOR ISOLATOR CONTACT DETAILS (1600A) ----- 4. FRM AP 02
 - FOR EARTH SWITCH CONTACT DETAILS ----- 4. FRE AP 03
 - FOR OPERATING MECHANISM DETAILS (M.S.) ----- 4. FN AP 04
 - FOR OPERATING MECHANISM DETAILS (E.S.) ----- 4. FN AP 05
 - FOR NAME PLATED DETAILS ----- 4. FZ AP 06
 - FOR MECHANICAL INTERLOCK DETAILS ----- 4. FZ AP 07

Thickness of Silver plating : 15 Microns Minimum

- NOTES:**
1. ALL DIMENSIONS ARE IN MILLIMETERS
 2. ALL FERROUS PARTS ARE HOT DIP GALVANIZED (87 MICRONS)
 3. ALL NON-FERROUS CONTACT POINTS ARE SILVER PLATED (100 MICRONS)
 4. THE INDICATED DIMENSIONS ARE SUBJECT TO THE MANUFACTURING TOLERANCE:
UP TO 50 mm ---±3%; 51 TO 100 mm ---±2%;
101 TO 300 mm ---±1%; ABOVE 300 mm ---±0.5%;
 5. SHORT TIME CURRENT RATING 31.5 KA rms. FOR 3 Sec.
 6. APPLICABLE STANDARD : IS:9921 PART I TO V ; IEC : 62271 - 102
 7. MAIN ROTATING POST HAVING 2 Nos. BALL BEARINGS OF ADEQUATE SIZE
 8. SUPPORT STRUCTURE & INSULATORS INCLUDING FIXING HARDWARE NOT IN OUR SCOPE OF SUPPLY

WEIGHT:
NET WEIGHT OF THE ISOLATOR
EXCLUDING INSULATOR : 650 Kg (Approx.)

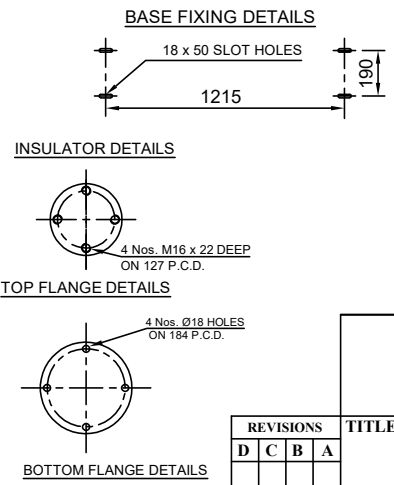
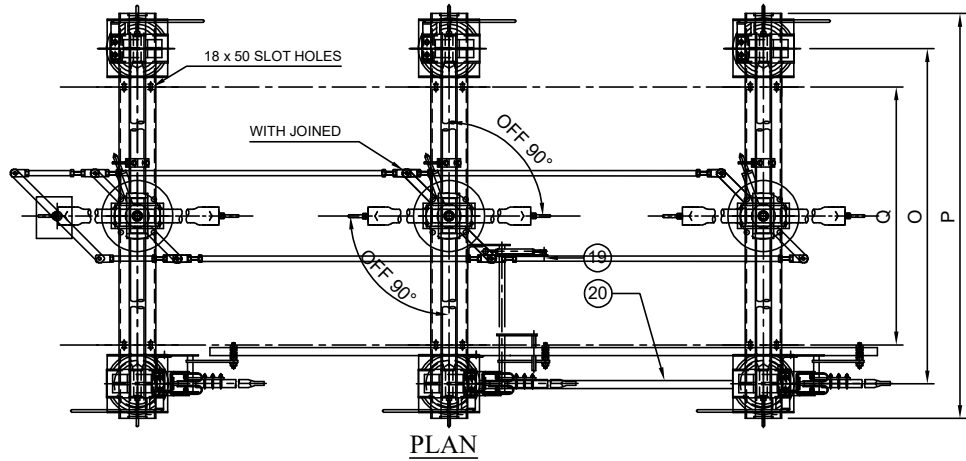

Drawing approval subject to valid vendor registration

DIMENSIONS

A	B	C	D	E	F	G	H	J	K		M	N	O	P	Q		S	T	U	W
175	1500	75	125	180	1420	120	1200	360	400		3000	190	2135	2500	1215		4675	2800	175	1425

REVISIONS			
D	C	B	A

Chief Engineer/Projects
APTRANSCO/VS/Vijayawada.

TITLE:
G.A. OF 145 kV, 1600 AMPS,
TP, HDB, RT, ISOLATOR WITH ONE E.S.
(MANUAL OPERATING MECHANISM)

SCALE: N.T.S

DATE: 21 - 03 - 2023

DRAWN:

CHECKED:

APPROVED:

DRG.NO: 3. FR AP 01

REV

GR POWER SWITCHGEAR LTD.,
JEEDIMETLA HYDERABAD-500 055 INDIA

FIXED CONTACT ASSEMBLY:

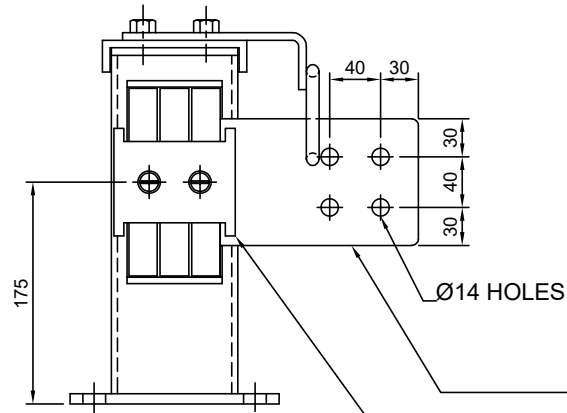

ELEVATION

NOTE: 1. DRAWING APPROVAL SUBJECT TO VALID TYPE TEST REPORTS, TO BE CHECKED DURING ACCEPTANCE TESTS
2. FOR EPC CONTRACTS ONLY

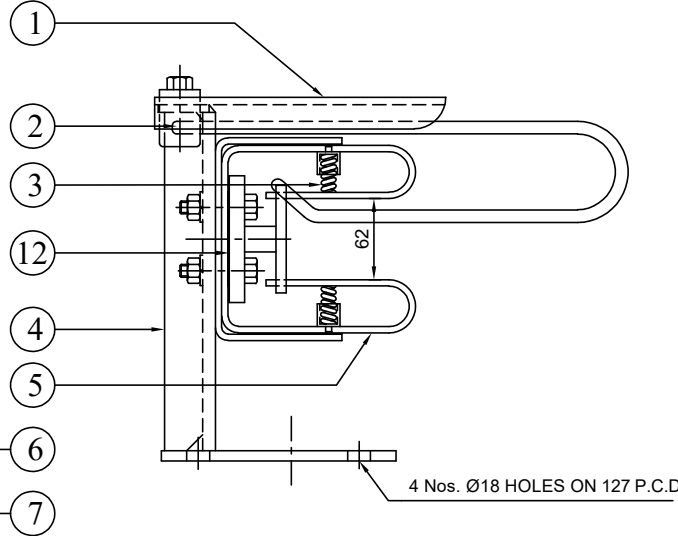

END VIEW

MOVING CONTACT ASSEMBLY

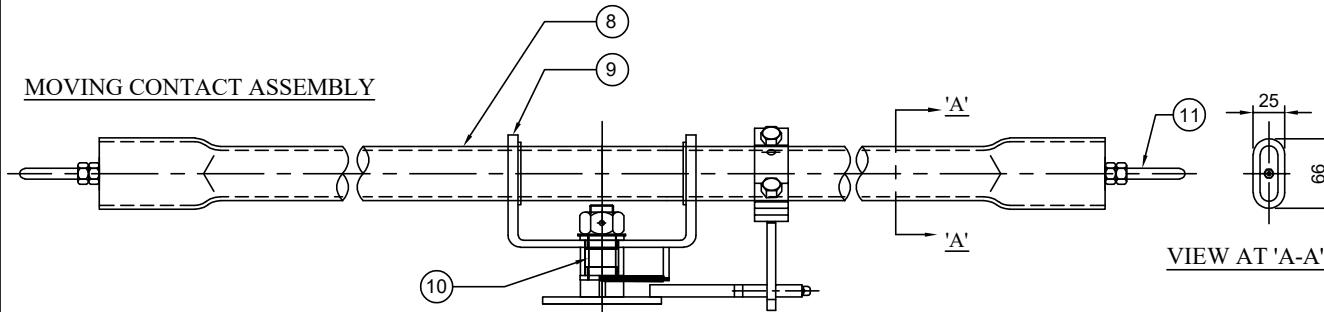

ELEVATION

VIEW AT 'A-A'

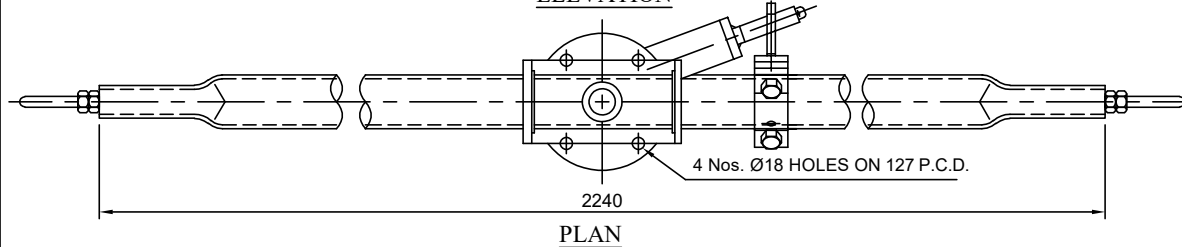

PLAN

PART LIST:

1. HOOD (18 SWG M.S. HDG)
2. ARCING HORNS (Ø10 ROD M.S. HDG)
3. SPRINGS (Ø2 mm STAINLESS STEEL.)
4. SUPPORTING CHANNEL (115 x 40 mm M.S. HDG)
5. JAWS (32 x 5.3 HDEC STRIP 3 Nos. SILVER PLATED)
6. JUMPER PLATE (100 x 16 ALU. FLAT)
7. SPACER (ALUMINUM)
8. MOVING CONTACT ARM (50 OD x 38 ID CU. TUBE)
9. MC SUPPORT WITH NYLON BUSH
10. CENTER MECHANISM (M.S. HDG, TURN & TWIST MECHANISM)
11. ARCING HORN FOR MOVING CONTACT (Ø10 ROD M.S. HDG)
12. BI-METALLIC SHEET (2 mm THICK Alu. + Cu.)

165	721
BOQ	
06 Nos	
06 Nos	
36 Nos	
06 Nos	
18 Nos	
06 Nos	
06 Nos	
03 Nos	
06 Nos	
03 Nos	
06 Nos	
06 Nos	

NOTE:

1. ALL DIMENSIONS ARE IN MILLIMETER
 2. ALL FERROUS PARTS ARE HOT DIP GALVANIZED
 3. ALL NON-FERROUS CONTACT POINTS ARE SILVER PLATED
MICRONS REMAINING CONTACT AREA TIN PLATED.
 4. THE MOVING CONTACT ASSEMBLY SHOWN FOR TURN & TWIST ASSEMBLY
- Thickness of Silver plating : 15 Microns Minimum

**Chief Engineer/Projects
APTRANSCO/VS/Vijayawada.**

Drawing approval subject to valid vendor registration

REVISIONS			
D	C	B	A

TITLE:	SCALE:N.T.S
MAIN CONTACT ASSEMBLY (FOR 145 kV 1600 Amps)	DATE: 21-07-2023
	DRAWN: [Signature]
	CHECKED: [Signature]
	APPROVED: [Signature]
GR POWER SWITCHGEAR LTD., JEEDIMETLA HYDERABAD-500 055 INDIA	DRG.NO: 4. FRM AP 02
	REV

FIXED CONTACT ASSEMBLY:

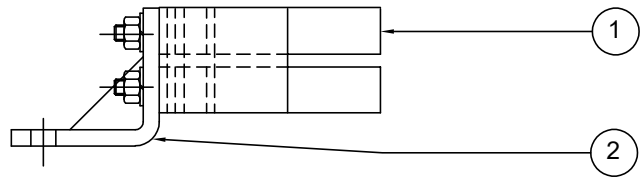

ELEVATION

- NOTE: 1. DRAWING APPROVAL SUBJECT TO VALID TYPE TEST REPORTS, TO BE CHECKED DURING ACCEPTANCE TESTS
2. FOR EPC CONTRACTS ONLY

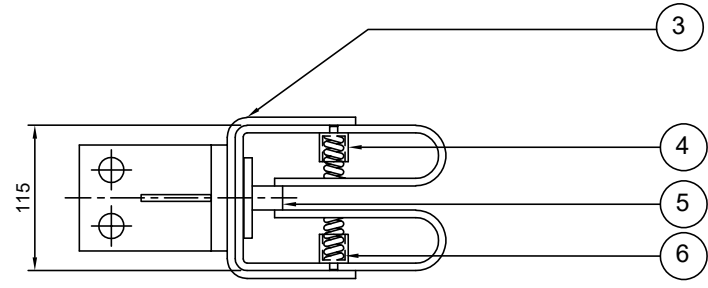

PLAN

MOVING CONTACT ASSEMBLY:

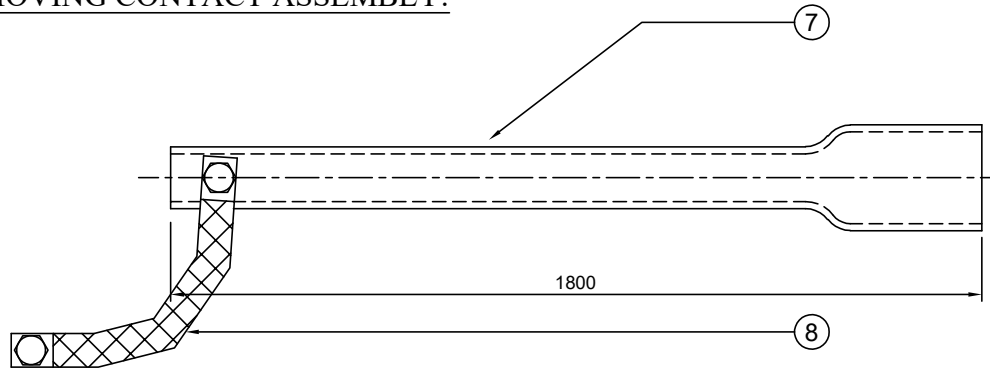

Drawing approval subject to valid vendor registration

PART LIST:

1. JAWS (2 Nos. 32 x 4 mm, Cu. FLAT SILVER PLATED)
2. F.C. SUPPORT PLATE (M.S. HDG)
3. JAW BRACKET (M.S. HDG)
4. SPRING HOLDER BUSH (NYLON)
5. SPACER (AL)
6. SPRINGS (14 SWG S.S. WIRE)
7. MOVING CONTACT ARM (38 OD x 30 ID CU. PIPE)
8. COPPER FLEXIBLE (25 x 4 mm, 4 Nos)

NOTE:

1. ALL DIMENSIONS ARE IN MILLIMETER
 2. ALL FERROUS PARTS ARE HOT DIP GALVANIZED
 3. ALL NON FERROUS CONTACT POINTS ARE SILVER PLATED
● MICRONS REMAINING CONTACT AREA TIN PLATED
- Thickness of Silver plating : 15 Microns Minimum

**Chief Engineer/Projects
APTRANSCO/VS/Vijayawada.**

REVISIONS			
D	C	B	A

TITLE:		SCALE:N.T.S	
EARTH SWITCH CONTACT ASSEMBLY FOR 132 KV		DATE	21/03/2023
		DRAWN	
		CHECKED	
		APPROVED	
		DRG.NO:	
		4. FRE AP 03	
GR POWER SWITCHGEAR LTD., JEEDIMETLA HYDERABAD-500 055 INDIA		REV	

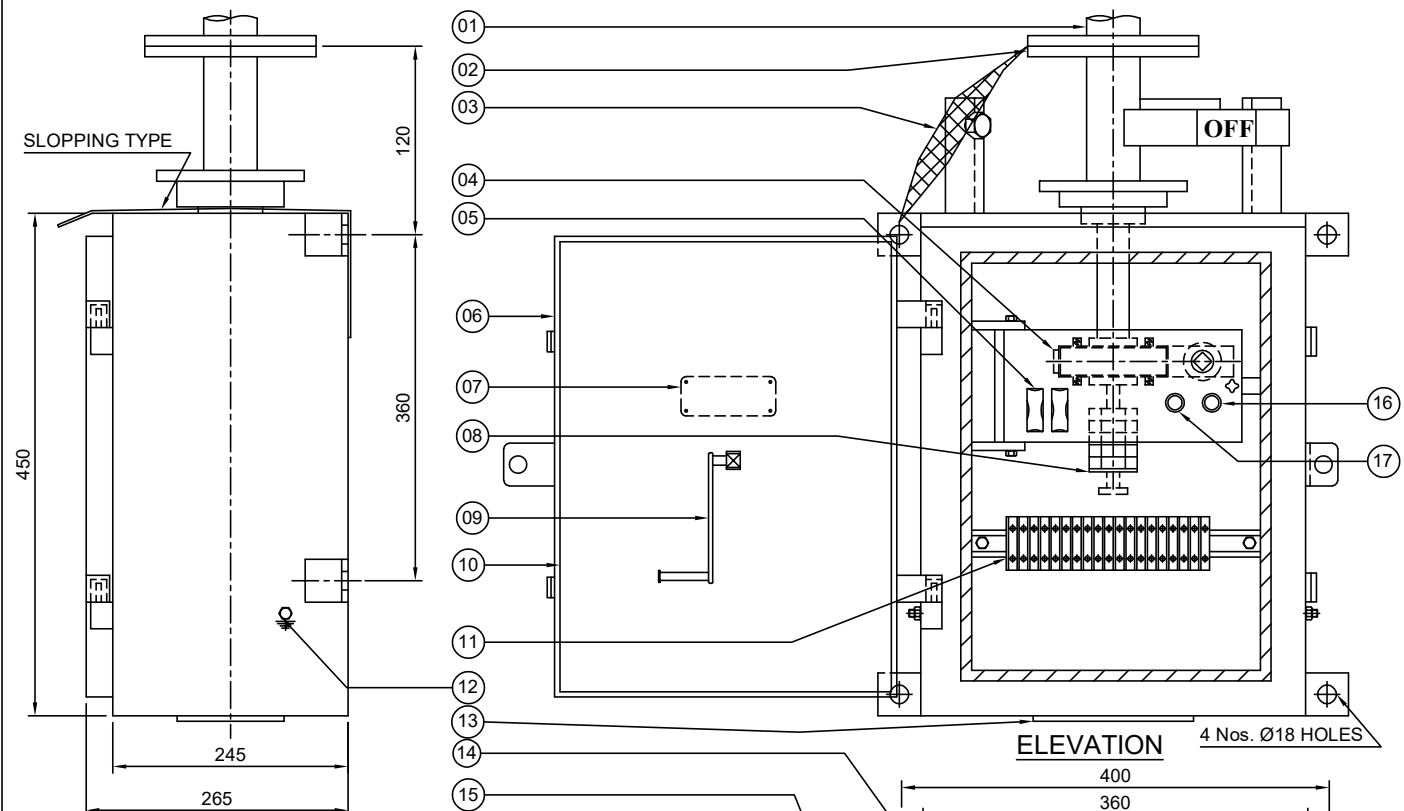

PART LIST

01. DOWN OPERATING PIPE
02. OUTPUT FLANGE (08 MM THICK M.S. PLATE)
03. COPPER FLEXIBLE (25 x 3 mm TINNED Cu. FLEXIBLE)
04. REDUCTION GEAR BOX (MATERIAL : EN8 / FORGED STEEL)
05. FUSES (2 A)
06. CUBICLE WITH DOOR (3 mm THICK, ALU. SHEET)
07. NAME PLATE
08. AUXILIARY SWITCH (6 NO + 6 NC)
09. OPERATING HANDLE
10. GASKET (EPDM)
11. TERMINAL BLOCKS (UBT - 4 OF ELEM X / VIN MECH OR ITS EQVT.)
12. PROVISION FOR EARTHING TERMINALS
13. DETACHABLE CABLE GLAND FIXING PLATE (WITHOUT GLANDS)
14. ON - OFF STOPPERS (M.S. ANGLE PAINTED)
15. RAIN SHADE
16. INDICATION LAMP
17. PUSH BUTTON (4 A)

NOTES:

1. ALL DIMENSIONS ARE IN MILLIMETER
2. CUBICLE WILL BE NATURAL FINISH FOR INSIDE AND OUTSIDE
3. DEGREE OF PROTECTION IP:55 AS PER IS:2147
4. WEIGHT OF THE BOX :28 Kg (Approx.)
5. WIRING WILL BE DONE WITH 1100 V GRADE 2.5 Sq. mm Cu. STANDED P.V.C. INSULATED CONDUCTOR
6. 20% SPARE TERMINALS PROVIDED
7. REDUCTION GEAR RATIO 20 : 1 MAKE GRPS MATERIAL OF GEAR EN8 / STEEL
8. LUBRICATION OF GARES : NON HARDENED GEARS FILLED GEAR BOX

LEGEND:

- F1,F2 ----- FUSES (2 Amp Rating)
- PB ----- PUSH BUTTON
- L ----- INDICATION LAMP
- SC ----- SOLENOID COIL

END VIEW

ELEVATION

4 Nos. Ø18 HOLES

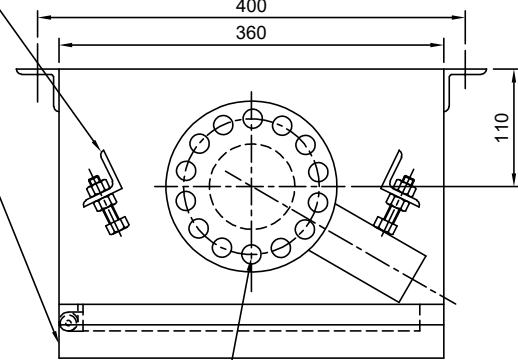

PLAN

14 Nos. Ø18 HOLES ON 127 PCD

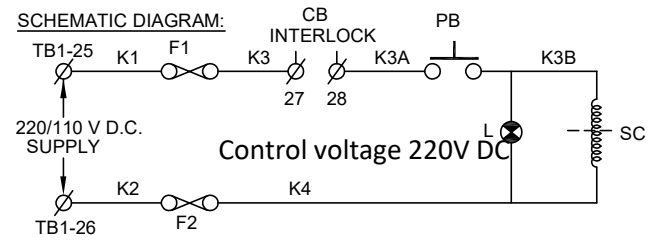

AUX. SWITCH CONTACT DETAILS FOR ISOLATOR (6 NO + 6 NC)

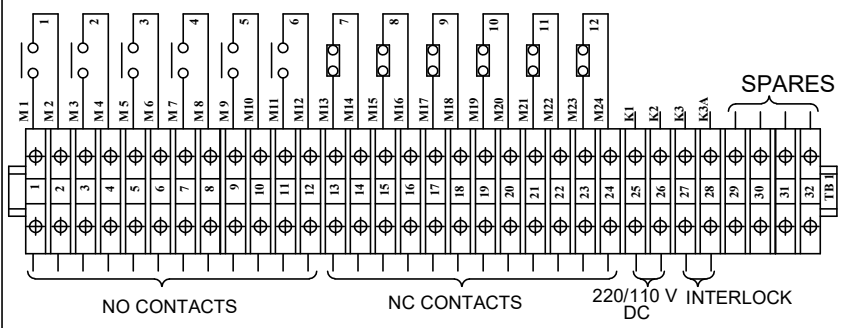

**Chief Engineer/Projects
APTRANSCO/VS/Vijayawada.**

REVISIONS

D	C	B	A

TITLE:
**OPERATING MECHANISM FOR
MAIN SWITCH
(FOR 132 KV)**



**GR POWER SWITCHGEAR LTD.,
JEEDIMETLA HYDERABAD-500 055 INDIA**

SCALE:N.T.S	
DATE	21-05-2023
DRAWN	
CHECKED	
APPROVED	

DRG.NO:	REV
4. FN AP 04	

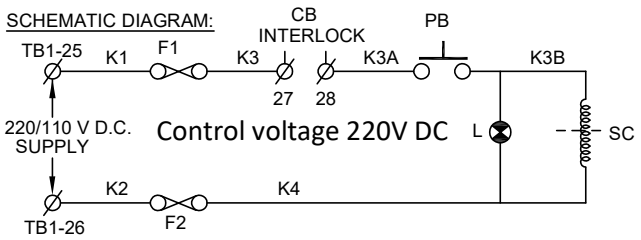
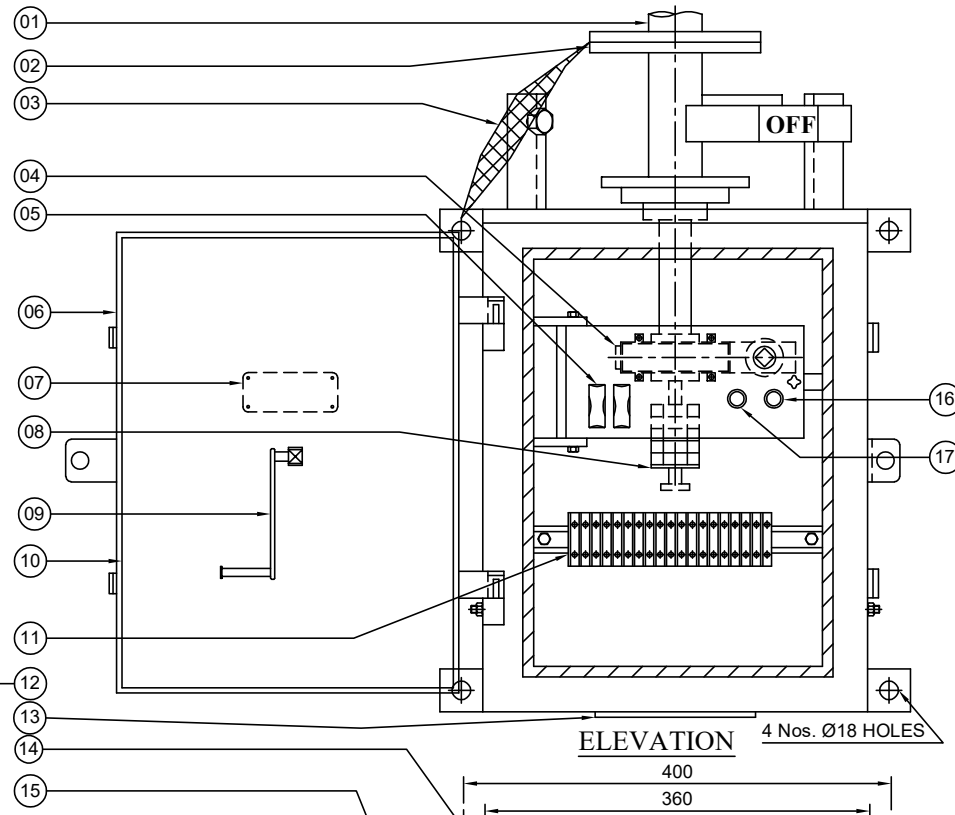
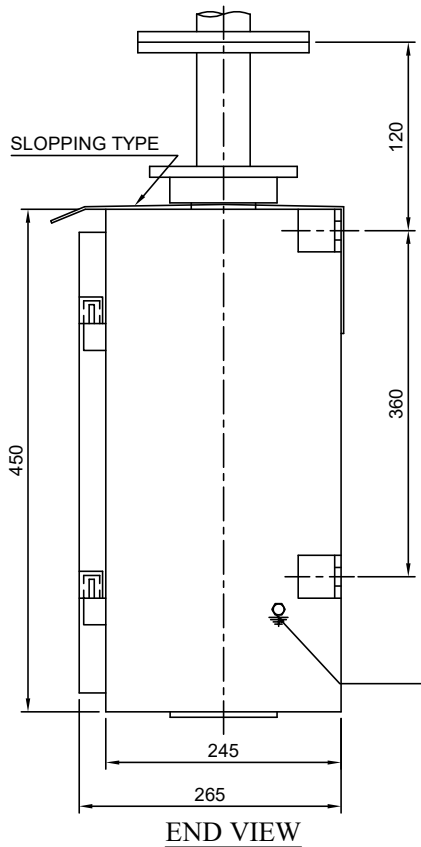

AUX. SWITCH CONTACT DETAILS FOR ISOLATOR (6 NO + 6 NC)

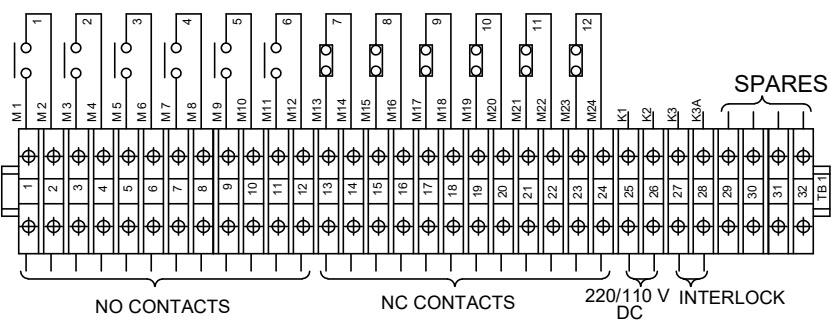

PLAN

PART LIST

01. DOWN OPERATING PIPE
02. OUTPUT FLANGE (08 MM THICK M.S. PLATE)
03. COPPER FLEXIBLE (25 x 3 mm TINNED Cu. FLEXIBLE)
04. REDUCTION GEAR BOX (MATERIAL : EN8 / FORGED STEEL)
05. FUSES (2 A)
06. CUBICLE WITH DOOR (3 mm THICK, ALU. SHEET)
07. NAME PLATE
08. AUXILIARY SWITCH (6 NO + 6 NC)
09. OPERATING HANDLE
10. GASKET (EPDM)
11. TERMINAL BLOCKS (UBT - 4 OF ELEM X / VIN MECH OR ITS EQVT.)
12. PROVISION FOR EARTHING TERMINALS
13. DETACHABLE CABLE GLAND FIXING PLATE (WITHOUT GLANDS)
14. ON - OFF STOPPERS (M.S. ANGLE PAINTED)
15. RAIN SHADE
16. INDICATION LAMP
17. PUSH BUTTON (4 A)

NOTES:

1. ALL DIMENSIONS ARE IN MILLIMETER
2. CUBICLE WILL BE NATURAL FINISH FOR INSIDE AND OUTSIDE
3. DEGREE OF PROTECTION IP:55 AS PER IS:2147
4. WEIGHT OF THE BOX :28 Kg (Approx.)
5. WIRING WILL BE DONE WITH 1100 V GRADE 2.5 Sq. mm Cu. STANDED P.V.C. INSULATED CONDUCTOR
6. 20% SPARE TERMINALS PROVIDED
7. REDUCTION GEAR RATIO 20 : 1 MAKE GRPS MATERIAL OF GEAR EN8 / STEEL
8. LUBRICATION OF GARES : NON HARDENED GEARS FILLED GEAR BOX

LEGEND:

- F1,F2 ----- FUSES (2 Amp Rating)
- PB ----- PUSH BUTTON
- L ----- INDICATION LAMP
- SC ----- SOLENOID COIL

Chief Engineer/Projects
APTRANSCO/Vs/Vijayawada.

REVISIONS

D	C	B	A

TITLE:
OPERATING MECHANISM FOR EARTH SWITCH (FOR 132 KV)



GR POWER SWITCHGEAR LTD.,
JEEDIMETLA HYDERABAD-500 055 INDIA

SCALE:N.T.S	
DATE	21-05-23
DRAWN	
CHECKED	
APPROVED	
DRG.NO:	4. FN AP 05
REV	

NAME PLATE DETAILS FOR ISOLATOR

NAME PLATE DETAILS FOR EARTH SWITCH

 MANUFACTURED & SUPPLIED BY GR POWER SWITCHGEAR LTD., JEEDIMETLA, HYDERABAD - 500 055	
CUSTOMER :	M/s. TRANSMISSION CORPORATION OF AP LIMITED
PROJECT :	-----
CONTRACTOR :	-----
P.O. NO :	----- Dt. : -----
TYPE :	HDB SL. NO : AS APPLICABLE YEAR OF Mfg. : -----
RATING :	Un 145 KV ; In : 1600 A ; WEIGHT IN KG : -----
IMPLUSE(UI) :	650 KV Peak; SWITCHING(Us) : NA KV Peak;
P.F. :	275 KV rms; STC(lth) : 31.5 KA rms; DURATION : 3 Sec;
OPERATING MECHANISM :	MANUAL (RG)
CONTROL VOLTAGE :	220/110 V DC CREEPAGE : -----

Control voltage 220V DC

 MANUFACTURED & SUPPLIED BY GR POWER SWITCHGEAR LTD., JEEDIMETLA, HYDERABAD - 500 055	
CUSTOMER :	M/s. TRANSMISSION CORPORATION OF AP LIMITED
PROJECT :	-----
CONTRACTOR :	-----
L.O.A./ P.O. NO :	----- Dt. : -----
TYPE :	VB SL. NO : AS APPLICABLE YEAR OF Mfg. : -----
RATING :	Un 145 KV ; In : ----- A ; WEIGHT IN KG : -----
IMPLUSE(UI) :	650 KV Peak; SWITCHING(Us) : NA KV Peak;
P.F. :	275 KV rms; STC(lth) : 31.5 KA rms; DURATION : 3 Sec;
OPERATING MECHANISM :	MANUAL (RG)
CONTROL VOLTAGE :	220/110 V DC CREEPAGE : -----

NOTE: 1. DRAWING APPROVAL SUBJECT TO VALID TYPE TEST REPORTS, TO BE CHECKED DURING ACCEPTANCE TESTS
 2. FOR EPC CONTRACTS ONLY

Project, contractor, PO, date ,year of MFG shall be stamped during inspection

- Minimum 300mm plinth shall be maintained for CT/PT/CVT/ Isolators/IVT in the substation during foundation works to ensure Safe live to ground clearance as per IE rules.
- since the supply of terminal connectors is not in the scope of Manufacturer as mentioned in the drawings. The EPC contractor Shall be instructed to supply the same in line with CT/PT/CVT/Isolator /IVTs requirement and compatibility.





NOTES :

- ENGRAVED LETTER SIZE : 3 mm
- LETTER ETCHED WHITE ON BLACK BACKGROUND
- MATERIAL : ALUMINIUM
- THICKNESS : 1 mm

Drawing approval subject to valid vendor registration

Chief Engineer/Projects
APTRANSCO/VS/Vijayawada.

REVISIONS			
D	C	B	A

TITLE:		SCALE:N.T.S	
NAME PLATE DETAILS FOR 132 KV ISOLATOR & E.S		DATE	21-08-2013
		DRAWN	
		CHECKED	
		APPROVED	
		DRG.NO:	REV
 GR POWER SWITCHGEAR LTD., JEEDIMETLA HYDERABAD-500 055 INDIA		4. FZ AP 06	

NOTE: 1. DRAWING APPROVAL SUBJECT TO VALID TYPE TEST REPORTS, TO BE CHECKED DURING ACCEPTANCE TESTS
 2. FOR EPC CONTRACTS ONLY

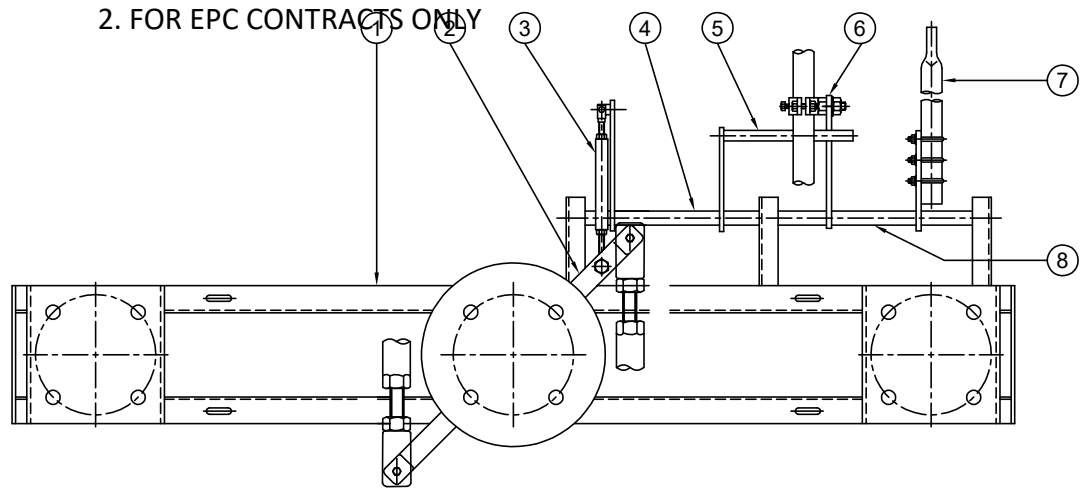

**FIG - 1 : ISOLATOR IN "CLOSE" POSITION
 EARTH SWITCH IN "OPEN" POSITION**

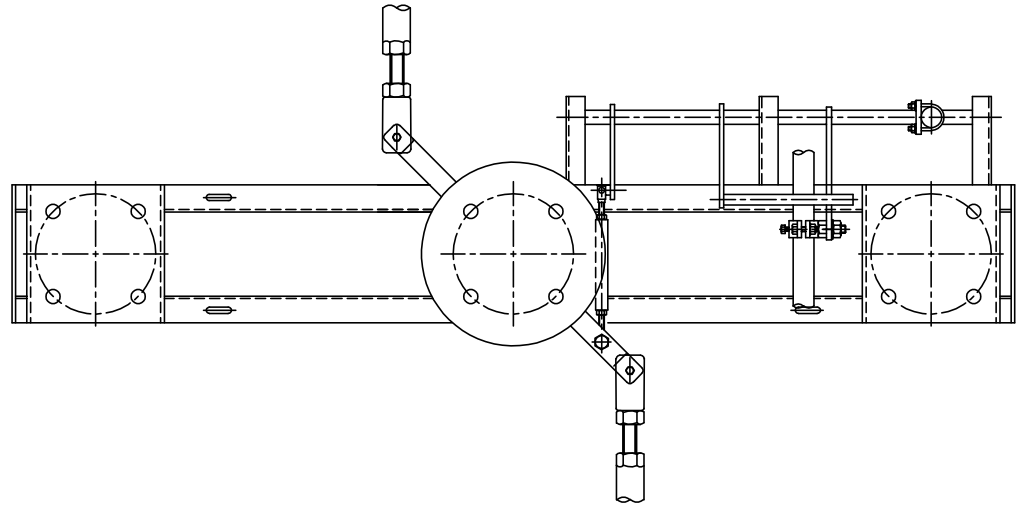

**FIG - 2 : ISOLATOR IN "OPEN" POSITION
 EARTH SWITCH IN "CLOSE" POSITION**

Drawing approval subject to valid vendor registration

CONSTRUCTION :

ISOLATOR OPERATING LEVER (2) IS CONNECTED TO THE ROTATION PIPE - 1 (4) THROUGH THE LINK ROD (3), THE STOPPER ROD (5) ALSO MOVES ALONG WITH THE ROTATING PIPE (4) EARTH SWITCH OPERATING LEVER (6) MOVES THE ROTATING PIPE - 2 (8) WITH EARTH SWITCH MOVING CONTACT (7) INDIVIDUALLY

FUNCTION :

IN FIG - 1 : IN THIS CONDITION THE ISOLATOR OPERATING LEVER (2) IS CONNECTED TO THE ROTATING PIPE - 1 (4) SUCH THAT THE STOPPER ROD (5) IS ABOVE THE EARTH SWITCH OPERATING LEVER (6) AS A RESULT THE STOPPER (5) WILL NOT PERMIT EARTH SWITCH OPERATING LEVER (6) TO MOVE AND THE E.S. MOVING CONTACT WILL REMAIN IN OPEN POSITION.

IN FIG - 2 : IN THIS CONDITION THE ISOLATOR OPERATING LEVER IS CONNECTED TO THE ROTATING PIPE - 1(4) SUCH THAT THE STOPPER ROD (5) WILL BE BELOW THE EARTH SWITCH OPERATING LEVER (6) AS A RESULT THE EARTH SWITCH OPERATING LEVER (6) WILL NOT PERMIT THE STOPPER ROD TO MOVE(5) AND ISOLATOR OPERATING LEVER (2) WILL REMAIN IN OPEN POSITION.

NOTES :

1. BASE CHANNEL 125 x 65 x 5 THK CHANNEL (HOT DIP GALVANIZED)
2. ISOLATOR OPERATING LEVER (40 x 10 mm THIK MS FLATTE)
3. LINK ROD (25 NB MS PIPE HDG)
4. ROTATING PIPE - 1 (25 NB MS PIPE HDG)
5. STOPPER ROD (20 Ø MS ROD HDG)
6. E.S. OPERATING LEVER (50 x 8 MS FLAT HDG)
7. E.S. MOVING CONTACT (38 OD x 30 ID CU. PIPE)
8. ROTATING PIPE - 2 (25 NB MS PIPE HDG)

**Chief Engineer/Projects
 APTRANSCO/VS/Vijayawada.**

REVISIONS			
D	C	B	A

TITLE: **MECHANICAL INTERLOCK BETWEEN MAIN SWITCH AND EARTH SWITCH**

SCALE:N.T.S	
DATE	21-05-2023
DRAWN	
CHECKED	
APPROVED	

**GR POWER SWITCHGEAR LTD.,
 JEEDIMETLA HYDERABAD-500 055 INDIA**

DRG.NO:	REV
4. FZ AP 07	

SCHEDULE OF GUARANTEED TECHNICAL PARTICULARS FOR 145 KV, 1600A WITH ONE EARTH SWITCH



S.No	DESCRIPTION		145 KV
1	Type/Installation	:	"DB" Double Break - OUTDOOR
2	Manufacturer's Name and country of manufacture	:	GR POWER SWITCHGEAR LTD.,
3	Standards according to which the isolators are manufactured.	:	IS 9921Part I to V.& IEC 62271-102
			Drawing approval subject to valid vendor registration
4	Maximum design voltage at which the isolator can operate (kV).	:	145 KV
5	Frequency (Hz)	:	50 Hz
6	Rated voltage (kV)	:	145KV
7	Maximum current that can be safely interrupted by the Isolator inductive (A & % PF) Capacitive (A & % PF)	:	0.7 Amps at 0.15 p.f.
8	Continuous current rating normal (Amps) under site conditions (Amps).	:	1600 Amps
9	Rated short time current		<u>MAIN SWITCH/ EARTH SWITCH</u>
	i) For 3 Seconds (kA rms)	:	31.5 KA rms
	ii) For 1 Second (kA rms)	:	Not Applicable
	iii) Rated peak short time current (KV P)	:	78.75 KA rms
10	Current density at the minimum cross section of		
	a) Moving blade (Amps/Sq.mm)	:	2.0 Amps/Sq.mm for HDE Cu. Tube
	b) Terminal pad	:	1.0 Amp/Sq.mm for EC grade Alu. Flat.
	c) Contacts	:	1.6 Amps/Sq.mm for HDE Cu. Flat.
11	Maximum temperature rise of current carrying parts when carrying rated current continuously (Deg.C).	:	Within the specified limits of IS/IEC 62271-102.
12	Insulation levels		
	i) Impulse withstand voltage (kV Peak) Phase to Earth Isolating Distance.	:	650/750 KV Peak
	ii) Switching surge withstand voltage (kV Peak) Phase to Earth isolating distance.	:	Not applicable

**Chief Engineer/Projects
APTRANSCO/VS/Vijayawada.**

S.No	DESCRIPTION		145 KV	
	iii) Power Frequency withstand voltage (kV rms) Phase to Earth isolating distance.	:	275/315 KV rms	
13	Minimum clearance in air		Drawing approval subject to valid vendor registration	
	i) Between poles (mm)	:		2700 mm for a phase spacing of 3000 mm
	ii) Between live parts and earth (mm)	:		1300 mm
	iii) Between live parts when switch is open.			
	a) On the same pole (mm)	:		1735 mm
	b) Between adjacent poles (mm)	:		2090 mm
14	Rated mechanical terminal load			
	i) Load along the terminal connector side (Kg).	:	51 Kgs	
	ii) Load across the terminal connector side (Kg).	:	17.3 Kgs	
15	Torque required to operate the switch in Kg.m.	:	40 Kg m	
16	Contact Zone		Not applicable	
	i) Horizontal deflection (mm)			
	ii) Vertical deflection (mm)	:		
	iii) Total amplitude of longitudinal movement w.r.t conductor supporting fixed contact			
17	Design and construction			
	i) No. of insulators per pole	:	Three	
	ii) No. of breaks per pole	:	Two	
	iii) Type of closing / opening mechanism (Horizontal / vertical break straight etc.).	:	Horizontal break for Isolator	
	iv. Contacts		Thickness of Silver plating : 15 Microns Minimum Hard Drawn Electrolytic Copper flat, silver plated  micron thickness.	
	a) Material and grade	:		
	b) Cross-sectional area (Sq.mm)	:	1017 Sq.mm for 1600A	

Chief Engineer/Projects
APTRANSCO/VS/Vijayawada.

GR POWER SWITCHGEAR LTD

S.No	DESCRIPTION	145 KV
v	Moving blades	
	a) Material and grade	Thickness of Silver plating : 15 Microns Minimum : Hard Drawn Electrolytic Copper tube, silver plated  micron thickness.
	b) Cross-sectional area (Sq.mm)	: 829 Sq.mm for 1600A
vi)	Contact support	
	a) Material and size of channel / block.	: 8 mm Thick MS HDG
vii)	Rain hood-material grade and size	: MS HDG
viii)	Turn and twist mechanism	
	a) Material and size of clamps	: 40 x 10 MS HDG Flat
	b) Material size of springs	: 10 swg SS wire
	c) Whether springs are encased	: Not encased
ix)	Nuts and bolts	
	a) Size, material and grade in live parts.	: Lessthan M8 are of stainless steel
	b) Size, material and grade in other parts.	: M8 and above are of MS HDG.
x)	Insulator base plate material and size of plate below insulators.	: 10 mm thick M.S. Hot dip galvanised plate
xi)	Bearings	
	a) Material and size of housing	: MS HDG suitable for 40 ID Ball Bearing
	b) No. of bearings, location & size	: 2 Nos. below centre rotating post insulator
xii)	Tandem pipe	
	a) Size, length class and No. of pipes	: As per GA drawings
	b) Size of shackle screw	: Suitable for  B Tandem Pipe size of Isolator /E.S/Aux Tandem Pipe Shall be Minimum 32 mm NB
	c) No. of bearings / bush and its material and size.	: 6 Nos. bush bearings, brass, 16 mm ID Size.
xiii)	Type of interlock	: Mechanical interlock between Isolator and Earth Switch.

Chief Engineer (Projects)

APTransco

S.No	DESCRIPTION		145 KV
	xiv) Down pipe size, length and class	:	50 mm NB Class B GI Pipe.
	xv) Type of universal/swivel joint		
	a) Between bearing & down pipe	:	Universal joint
	b) Between down pipe and operating mechanism.	:	Vernier Flange
	xvi) Operating mechanism		Manual operated mechanism for M.S. & E.S
	a) Control cabinet		
	Material and thickness	:	3 MM Thick ALU Sheet
	Degree of protection	:	IP : 55 as per IS 2147
	Type size and no. of cable glands.	:	Compression type, 2 Nos. 19 mm. (Contractor scope of supply)
	Whether removable gland plate provided.	:	Yes, removable gland plate provided.
	b) Make type, rating and Qty. of Motors	:	Not Applicable
	Auxiliary blocks	:	6 NO / 6 NC contacts for Manual operated Main Switch 6 NO / 6 NC contacts for Earth Switch Mani 10 A, 2 A DC breaking with 2A - 1 No.
	Terminal blocks	:	UBT-4
	Insulated Wires	:	1100 V grades, 2.5 Sq.mm PVC
	HRC Fuse	:	Applicable for RG Box
	Space Heater	:	Not applicable
	Interlocks	:	1 Set PSI / 20 Watts magnetic - 1 No.
	xvii) Base		
	a) Size of steel sections used	:	125 X 65 mm
	b) Overall size	:	2500 x 125 x 65 mm x 5 mm
	c) Total weight	:	28 Kgs approx

for GR POWER SWITCHGEAR LTD.,



AUTHORIZED SIGNATORY

Chief Engineer (Projects)

APTransco