

NOTE:- THIS COMPLETE SET OF DRAWINGS ARE REPRESENTATIVE OF THE LATEST TYPE TEST REPORT AND PROPRIETARY DESIGN, RESEARCH & DEVELOPMENT OF SWITCHGEAR MANUFACTURING COMPANY PVT. LTD. GANDRAJAPALLE. THE DESIGNS SHALL NOT BE REPRODUCED WITHOUT WRITTEN CONSENT OF SWITCHGEAR MANUFACTURING COMPANY PVT. LTD. GANDRAJAPALLE.

NOTE: 1. Drawings Approval subject to valid type test reports, to be checked during acceptance tests.
2. For EPC contractors only.

Drawing approval subject to valid vendor registration



1. Minimum 300mm plinth shall be maintained for CT/PT/CVT/Isolators/IV/LA/Breakers in the substation during foundation works to ensure safe live to ground clearance per IE rules.
2. Since the supply of terminal connectors is not in the scope of manufacturer as mentioned in the drawings. The EPC contractor shall be instructed to supply the same line with CT/PT/CVT/Isolator/IVT/LA/Breaker's requirement and compatibility.

			73
			765
REV	DATE	CHANGES MADE	SIG

LIST OF DRAWINGS/DOCUMENTS 145KV DBR DISCONNECTOR

S NO.	TITLE	DRAWING NO.	REV	SHEET
1	GA OF 145kv 800A 'DBR' DISCONNECTOR WITH ONE EARTH SWITCH	STD-1450006	0	1 OF 1
2	DETAILS OF MAIN CONTACT (145KV 800A DBR DISCONNECTOR)	STD-1450007	0	1 OF 1
3	EARTH SWITCH CONTACT DETAILS (FOR 145KV DBR DISCONNECTOR)	STD-1450008	0	1 OF 1
4	GA OF MANUAL OPERATING MECHANISM FOR DISCONNECTOR	STD-1450009	0	1 OF 1
5	GA OF MANUAL OPERATING MECHANISM FOR EARTH SWITCH	STD-1450010	0	1 OF 1
6	MECHANICAL INTERLOCK BETWEEN MAIN SWITCH & EARTH SWITCH	STD-1450011	0	1 OF 1
7	NAME PLATE DETAILS (FOR 145KV DBR DISCONNECTOR)	STD-1450012	0	1 OF 1

**CHIEF ENGINEER/PROJECTS
APTRANSCO/VISVIJAYAWADA**

DRN	YVG	04.06.22		SWITCHGEAR MANUFACTURING COMPANY	
CHKD	VK	04.06.22		GANDRAJUPALLE, CHITTOOR DIST, A.P, INDIA.	
APPD	OJA	04.06.22		TITLE	
DEPT	SIGN	DATE	FOR 145KV DBR DISCONNECTOR		
	SC: NTS	Paper size A3	DRG.NO. S T D -	1 4 5 0 0 0 5	SHEET 1 OF 1
					REV. 0

NOTE:- THIS COMPLETE SET OF DRAWINGS ARE REPRESENTATIVE OF THE LATEST TYPE TEST REPORT AND PROPRIETARY DESIGN, RESEARCH & DEVELOPMENT OF SWITCHGEAR MANUFACTURING COMPANY PVT. LTD. GANDRAJAPALLE. THE DESIGNS SHALL NOT BE REPRODUCED WITHOUT WRITTEN CONSENT OF SWITCHGEAR MANUFACTURING COMPANY PVT. LTD. GANDRAJAPALLE.

NOTE: 1. Drawings Approval subject to valid type test reports, to be checked during acceptance tests.
 2. For EPC contractors only.

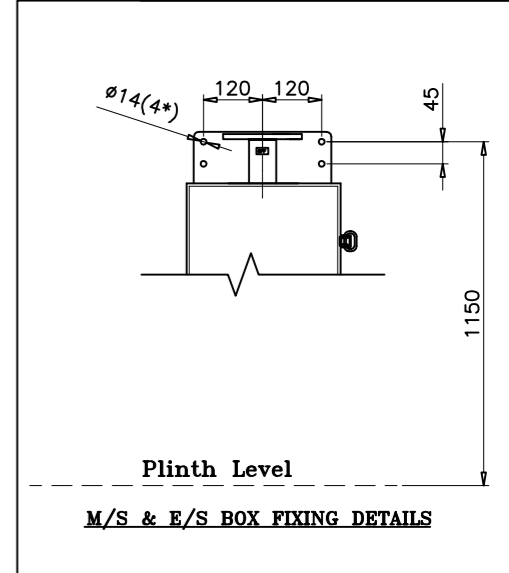
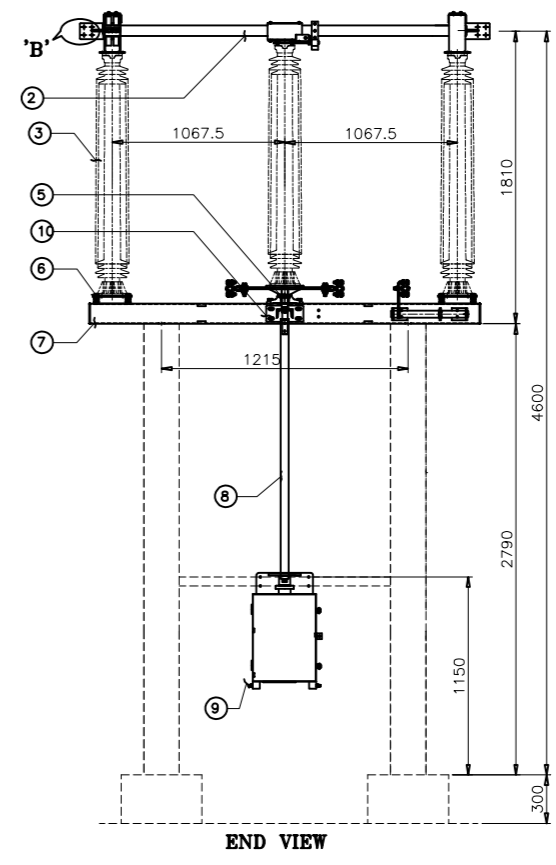
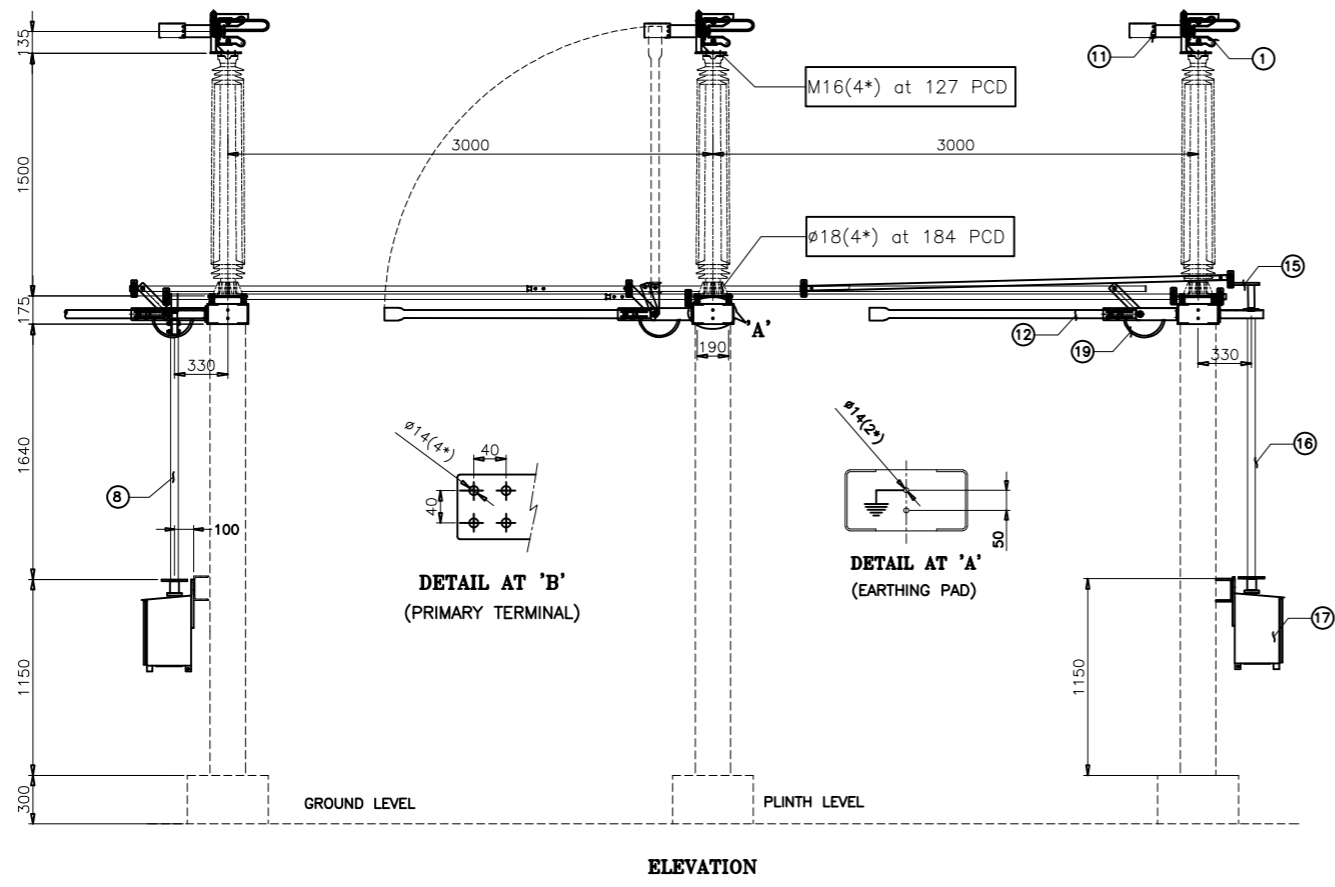

PT.	DESCRIPTION	QTY
19	COPPER BRAIDED FLEXIBLE	03
18	LINK MECHANISM (M/S&E/S)	01
17	E/S OPERATING MECHANISM BOX(MANUAL)	01
16	E/S OPERATING PIPE(50NB GI PIPE)	01
15	E/S TOP OPERATING MECH.	01
14	E/S AUX. TANDEM PIPE(32 NB GI PIPE)	01
13	E/S TANDEM PIPE(32 NB GI PIPE)	01
12	E/S MOVING CONTACT	03
11	E/S FIXED CONTACT	03
10	TOP OPERATING MECHANISM	01
9	OPERATING MECHANISM BOX(MANUAL-HR)	01
8	OPERATING PIPE(50 NB GI PIPE)	01
7	BASE CHANNEL(125X65X5MM THK)	03
6	ELEVATOR PLATE (10MM THK-MS HDG)	06
5	ROTATING STOOL POST(MS HDG)	03
4	TANDEM PIPE(32 NB GI PIPE)	02
3	INSULATOR STACK	09
2	MOVING CONTACT ASSLY	03
1	FIXED CONTACT ASSLY	06
PT.	DESCRIPTION	QTY
PART LIST		

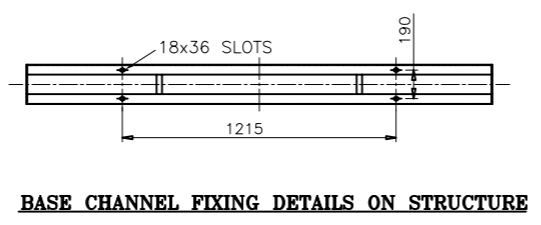
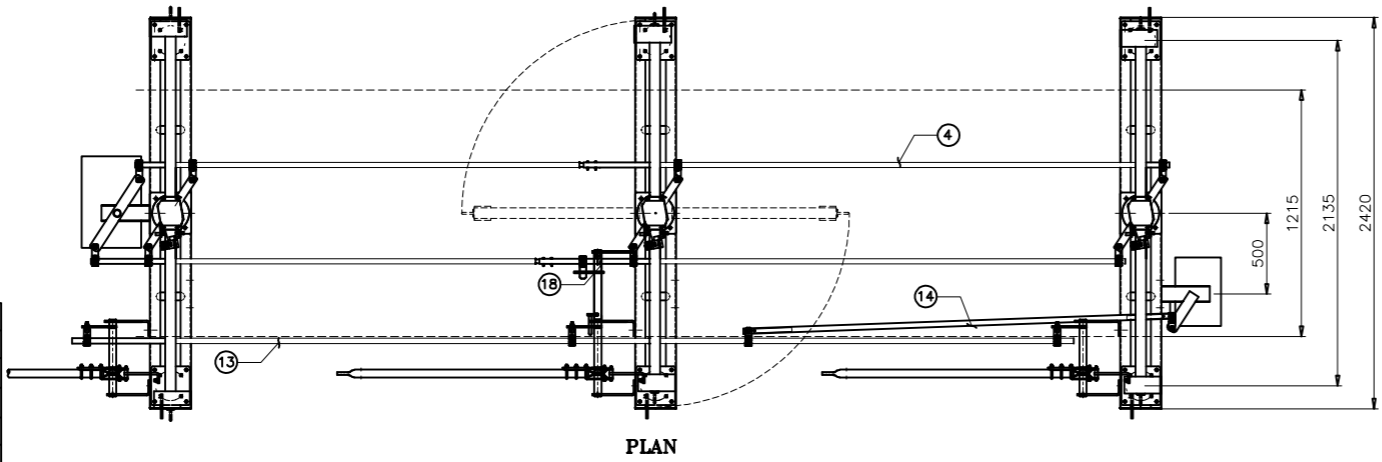

CHIEF ENGINEER/PROJECTS
APTRANSCO/VISVIJAYAWADA

Drawing approval subject to valid vendor registration

- NOTES**
- ALL DIMENSIONS ARE IN 'mm'
 - ALL FERROUS PARTS ARE HOT DIP GALVANIZED WITH 85 MICRONS.
 - ALL NON-FERROUS CONTACT POINTS ARE SILVER PLATED. WITH 15 MICRONS.
 - THE MAIN ROTATING POST HAS TWO NOS OF BEARING
 - ALL GI PIPES ARE OF 'B' CLASS AS PER IS:1239
 - MANUFACTURING TOLERANCES
 - i) UPTO 50mm-- ±3% ii) 51 to 100mm-- ±2%
 - iii) 101 to 300mm-- ±1% iv) ABOVE 300mm-- ±0.5%

DRN	YVG	04.06.22	SWITCHGEAR MANUFACTURING COMPANY GANDRAJUPALLE, CHITTOOR DIST, A.P, INDIA.
CHKD	VK	04.06.22	
APPD	OJA	04.06.22	
DEPT	SIGN	DATE	
SC: NTS	Paper size	A3	TITLE GENERAL ARRANGEMENT OF 145KV 800A DBR DISCONNECTOR WITH ONE EARTH SWITCH
DRG.NO. S T D - 1 4 5 0 0 0 6			SHEET 1 OF 1
			REV. 0

REV	DATE	CHANGES MADE	SIG
REF. STANDARD	IEC:62271-102/IS:9921		
CONTROL VOLTAGE DC	V	220	
CROSS	kg	17.5	
TL STRAIGHT	kg	51	
ACROSS	kVp	315	
PF TO EARTH	kVp	275	
ACROSS	kVp	750	
TO EARTH	kVp	650	
STC PEAK	kAp	78.75	
FOR 1Sec	kA	31.5	
CURRENT	Amps	800	
VOLTAGE	kV	145	
DESCRIPTION	UNIT	VALUE	
TECHNICAL DATA			

DETAILS OF FIXED CONTACT

NOTE: 1. Drawings Approval subject to valid type test reports, to be checked during acceptance tests.
2. For EPC contractors only.

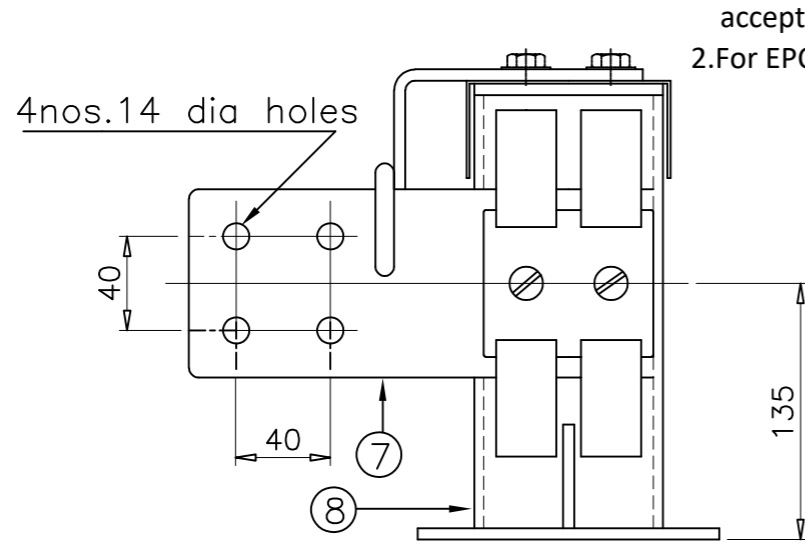

ELEVATION

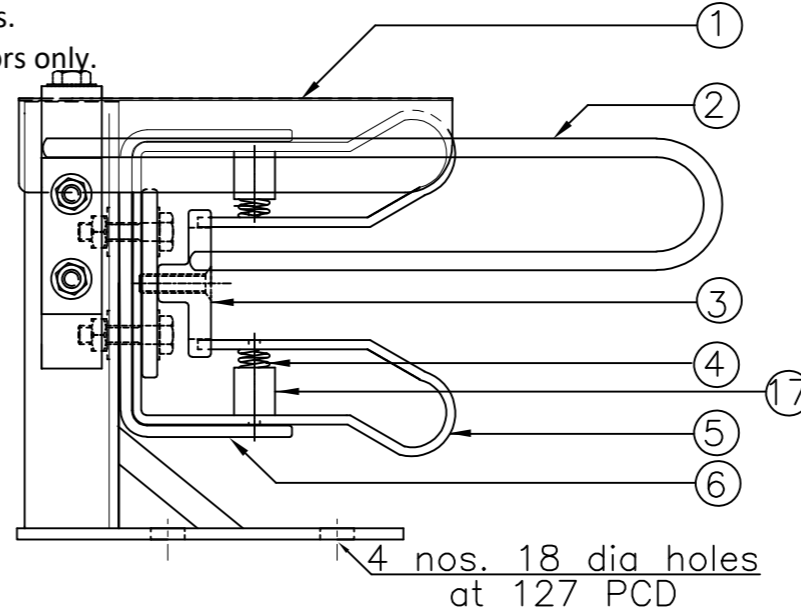

END VIEW

NOTES

1. All dimensions are in 'mm'
2. All ferrous parts are hot-dip galvanized
3. All non-ferrous contact points are silver plated upto 15 microns
4. Tolerances
 - (i) Upto 50mm --- ±3%
 - (ii) 51 to 100 mm --- ±2%
 - (iii) 101 to 300mm --- ±1%
 - (iv) Above 300mm --- ±0.5%
5. Bolted area are Tin plated up to 10 microns to avoid bi-metallic reaction between Cu & Al

DETAILS OF MOVING CONTACT

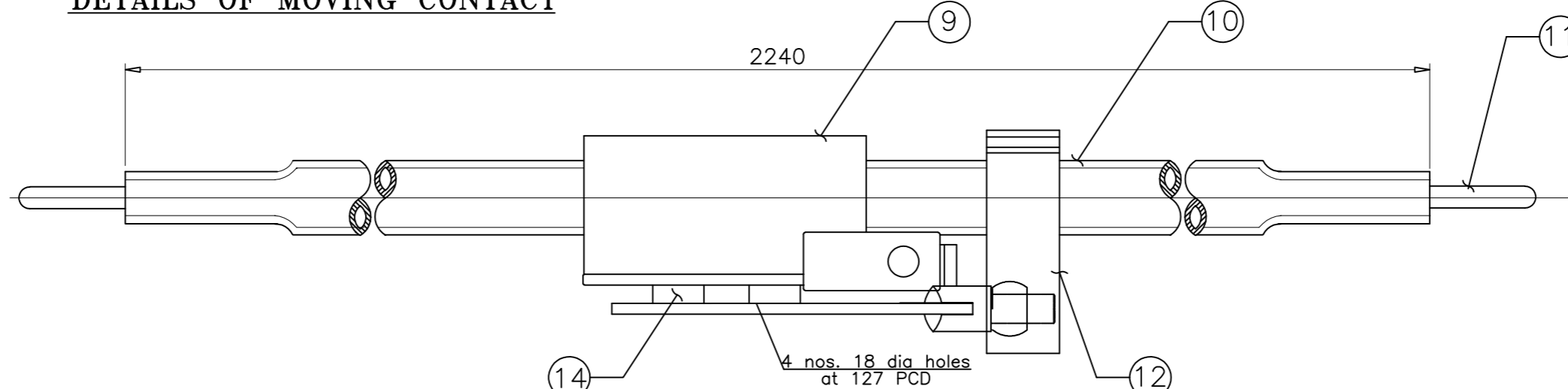

ELEVATION

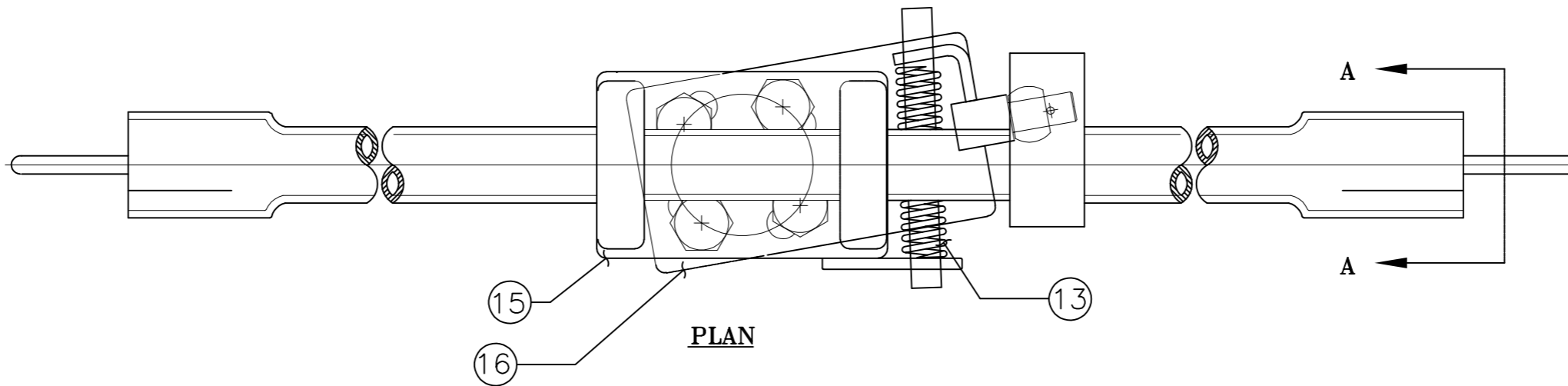

PLAN

**CHIEF ENGINEER/PROJECTS
APTRANSCO/VISVIJAYAWADA**

VIEW AT-'AA'

NOTE:- THIS COMPLETE SET OF DRAWINGS ARE REPRESENTATIVE OF THE LATEST TYPE TEST REPORT AND PROPRIETARY DESIGN, RESEARCH & DEVELOPMENT OF SWITCHGEAR MANUFACTURING COMPANY PVT. LTD. GANDRAJAPALLE. THE DESIGNS SHALL NOT BE REPRODUCED WITHOUT WRITTEN CONSENT OF SWITCHGEAR MANUFACTURING COMPANY PVT. LTD. GANDRAJAPALLE.

PART LIST

1. FC rain hood (AL.)
2. FC Arcing horn (MS HDG)
3. Spacer (AL.)
4. FC spring (SS)
5. FC Jaw (2 Nos. 32x4 HDE Cu.flat)
6. Jaw back strip (MS HDG)
7. Jumper pad (75x12 Al. flat)
8. Supporting channel (MS HDG)
9. MC Rain Hood (AL.)
10. MC arm (38 OD 30 ID Cu. tube)
11. MC Arcing horn (MS HDG)
12. MC Clamp (MS HDG)
13. MC Spring (SS)
14. Spacer Bush (BRASS)
15. MC top plate (MS HDG)
16. MC bottom plate (MS HDG)
17. Bush (plastic)

Sl.No.	Cross section	Area	Current Rating	Current Density (Amps/sq.mm)	DRN	YVG	04.06.22	SWITCHGEAR MANUFACTURING COMPANY GANDRAJUPALLE, CHITTOOR DIST, A.P, INDIA.		
1	(FC JAWS) 32X4X(2X2)	512mm ²	800A	1.56	CHKD	VK	04.06.22			
2	(MC ARM) 38 OD X 30 ID	427.04mm ²	800A	1.87	APPD	OJA	04.06.22			
2	JUMPER PAD (75X12)	900mm ²	800A	0.88	DEPT	SIGN	DATE	TITLE		
								MAIN CONTACT DETAILS (FOR 145KV 800A DBR DISCONNECTOR)		
							Paper size A3	DRG.NO. S T D - 1 4 5 0 0 0 7	SHEET 1 of 1	REV. 0

			75
			765
REV	DATE	CHANGES MADE	SIG

NOTE:- THIS COMPLETE SET OF DRAWINGS ARE REPRESENTATIVE OF THE LATEST TYPE TEST REPORT AND PROPRIETARY DESIGN, RESEARCH & DEVELOPMENT OF SWITCHGEAR MANUFACTURING COMPANY PVT. LTD. GANDRAJAPALLE. THE DESIGNS SHALL NOT BE REPRODUCED WITHOUT WRITTEN CONSENT OF SWITCHGEAR MANUFACTURING COMPANY PVT. LTD. GANDRAJAPALLE.

NOTE: 1. Drawings Approval subject to valid type test reports, to be checked during acceptance tests.
 2. For EPC contractors only.

FIXED CONTACT DETAILS

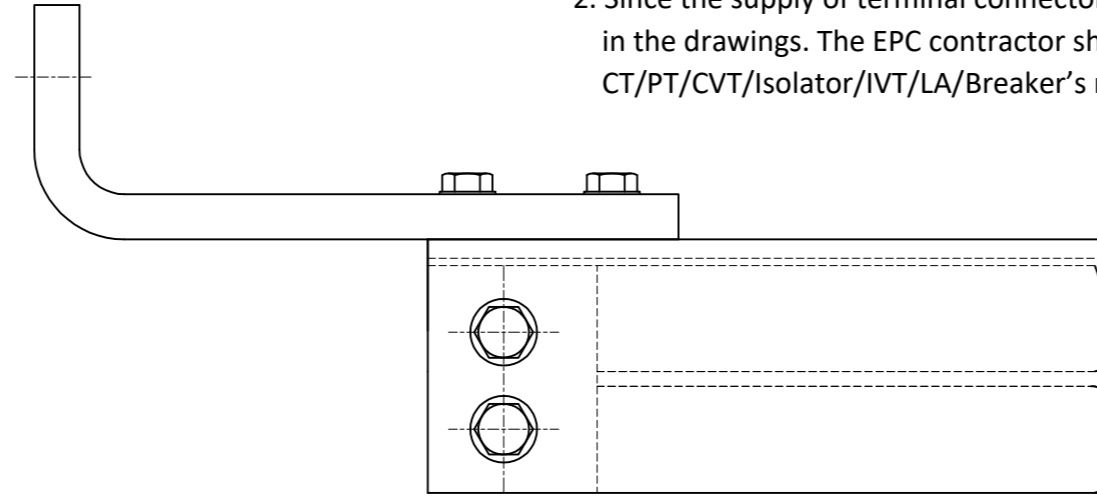

ELEVATION

1. Minimum 300mm plinth shall be maintained for CT/PT/CVT/Isolators/IV/LA/Breakers in the substation during foundation works to ensure safe live to ground clearance per IE rules.
2. Since the supply of terminal connectors is not in the scope of manufacturer as mentioned in the drawings. The EPC contractor shall be instructed to supply the same line with CT/PT/CVT/Isolator/IVT/LA/Breaker's requirement and compatibility.

Drawing approval subject to valid vendor registration

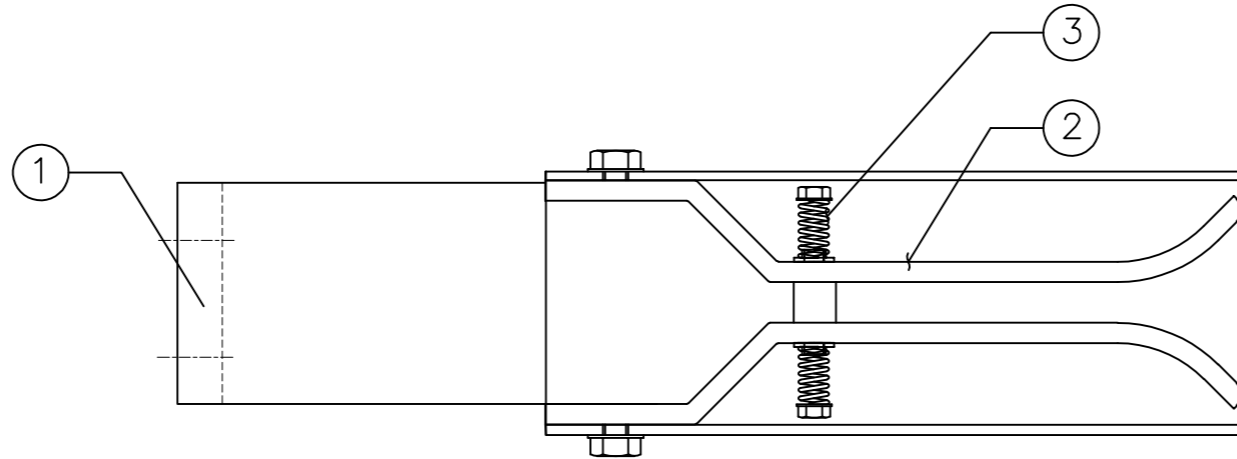

PLAN

MOVING CONTACT DETAILS

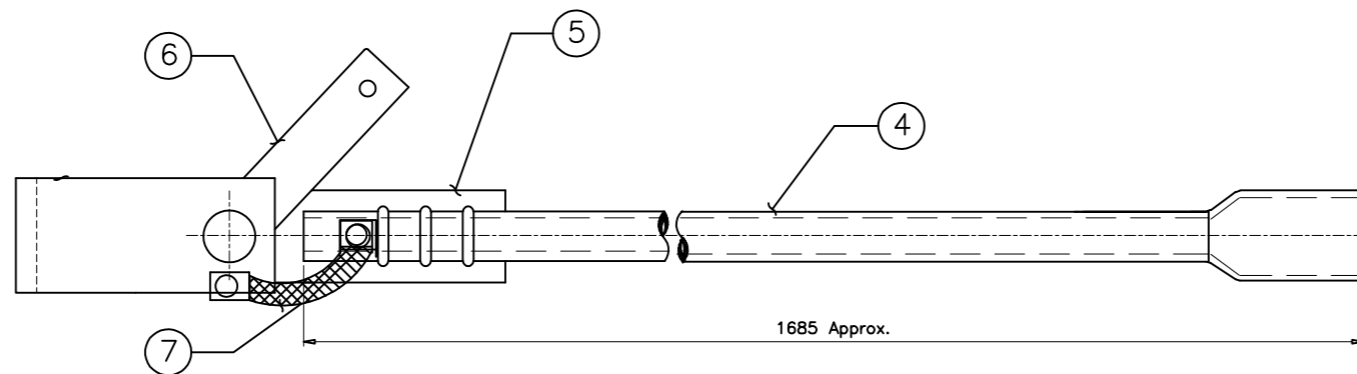

1685 Approx.

CHIEF ENGINEER/PROJECTS
APTRANSCO/VS/VIJAYAWADA

NOTES

1. ALL DIMENSIONS ARE IN 'MM'
2. ALL HDE COPPER CONTACT POINTS ARE SILVER PLATED WITH 15 MICRONS.
3. MANUFACTURING TOLERANCES
 - i) UPTO 50mm-- ±3% ii) 51 to 100mm-- ±2%
 - iii) 101 to 300mm-- ±1% iv) ABOVE 300mm-- ±0.5%
4. (*) CONTACT AREA ARE SILVER PLATED & BOLTED AREA ARE TIN PLATED TO AVOID BI-METALLIC REACTION BETWEEN Cu. & Al.
5. BOLTED AREA ARE TIN PLATED UP TO 10 MICRONS TO AVOID BI-METALIC REACTION BETWEEN CU & AL

7	Copper braided flexible	(Ø10mm Cu. rope, 5 Nos)
6	MC Lever	MS HDG
5	MC Fixing plate	MS HDG
4	MC ARM	38 OD 30 ID Cu. Tube
3	FC Spring	SS
2	FC JAW	2 no's 50X5 Cu. flat
1	FC SUPPORTING STRIP	75X12 Al.
PT.	DESCRIPTION	
SL.NO	PART LIST	MATL

DRN	YVG	04.06.22	SWITCHGEAR MANUFACTURING COMPANY GANDRAJUPALLE, CHITTOOR DIST, A.P, INDIA.
CHKD	VK	04.06.22	
APPD	OJA	04.06.22	
DEPT	SIGN	DATE	
SC: NTS	Paper size	A3	TITLE EARTH SWITCH CONTACT DETAILS (FOR 145KV DBR DISCONNECTOR)
DRG.NO. S T D - 1 4 5 0 0 0 8			SHEET 1 of 1
			REV. 0

			76
			765
REV	DATE	CHANGES MADE	SIG

NOTE:- THIS COMPLETE SET OF DRAWINGS ARE REPRESENTATIVE OF THE LATEST TYPE TEST REPORT AND PROPRIETARY DESIGN, RESEARCH & DEVELOPMENT OF SWITCHGEAR MANUFACTURING COMPANY PVT. LTD. GANDRAJAPALLE. THE DESIGNS SHALL NOT BE REPRODUCED WITHOUT WRITTEN CONSENT OF SWITCHGEAR MANUFACTURING COMPANY PVT. LTD. GANDRAJAPALLE.

NOTE: 1. Drawings Approval subject to valid type test reports, to be checked during acceptance tests.
 2. For EPC contractors only.

1. Minimum 300mm plinth shall be maintained for CT/PT/CVT/Isolators/IV/LA/Breakers in the substation during foundation works to ensure safe live to ground clearance per IE rules.
 2. Since the supply of terminal connectors is not in the scope of manufacturer as mentioned in the drawings. The EPC contractor shall be instructed to supply the same line with CT/PT/CVT/Isolator/IVT/LA/Breaker's requirement and compatibility.

			77
			765
REV	DATE	CHANGES MADE	SIG

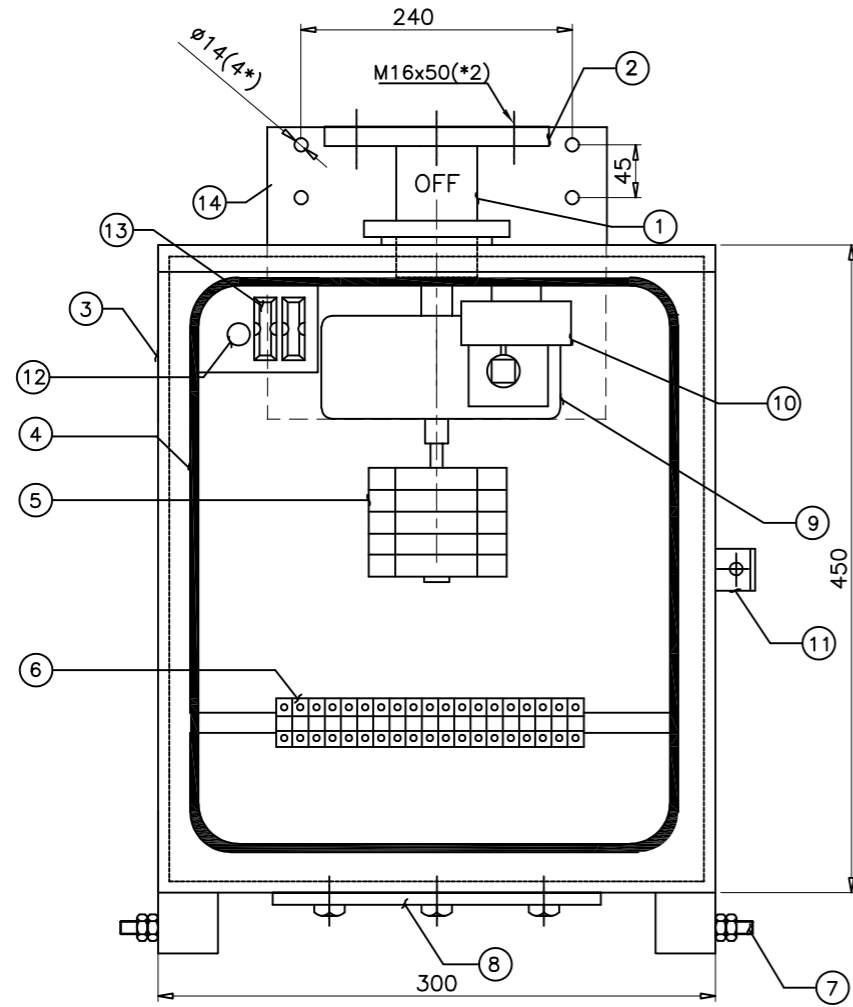

ELEVATION

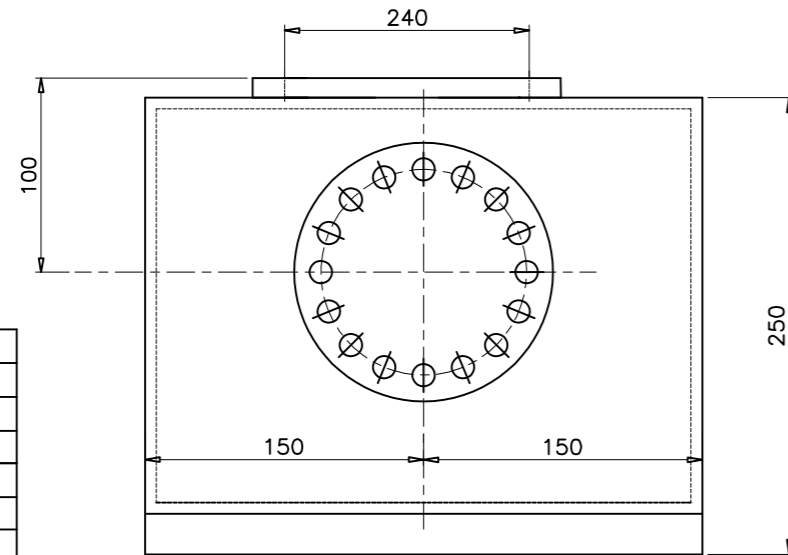

PLAN

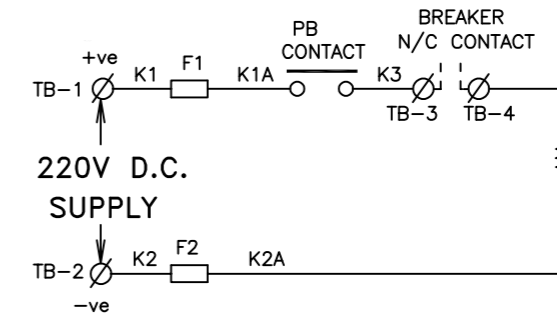
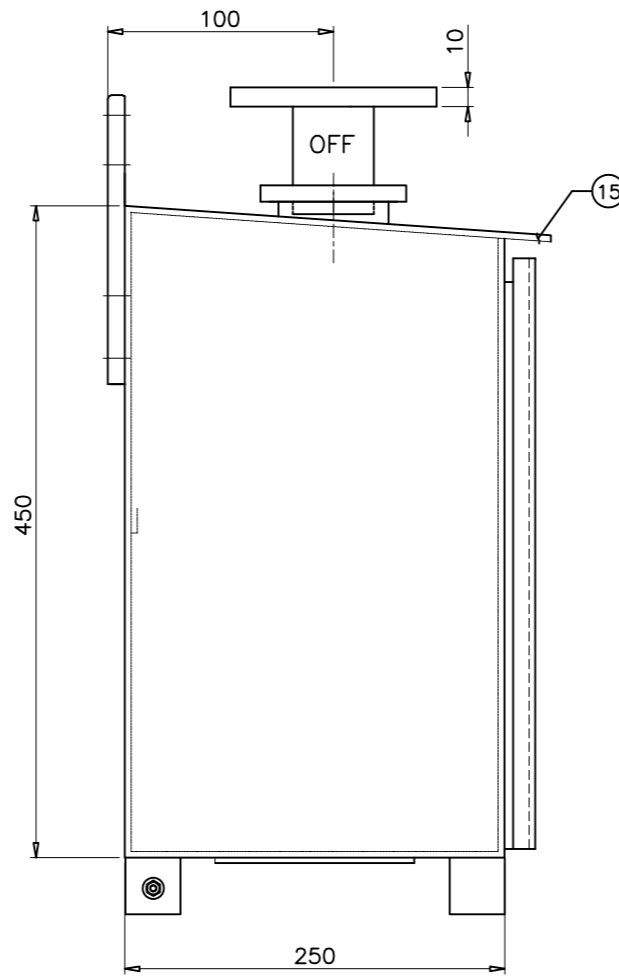

SCHEMATIC DIAGRAM (D.C)

LEGEND
 F1,F2 : Fuses for control supply
 PB : Push button
 S.C. : Solenoid coil

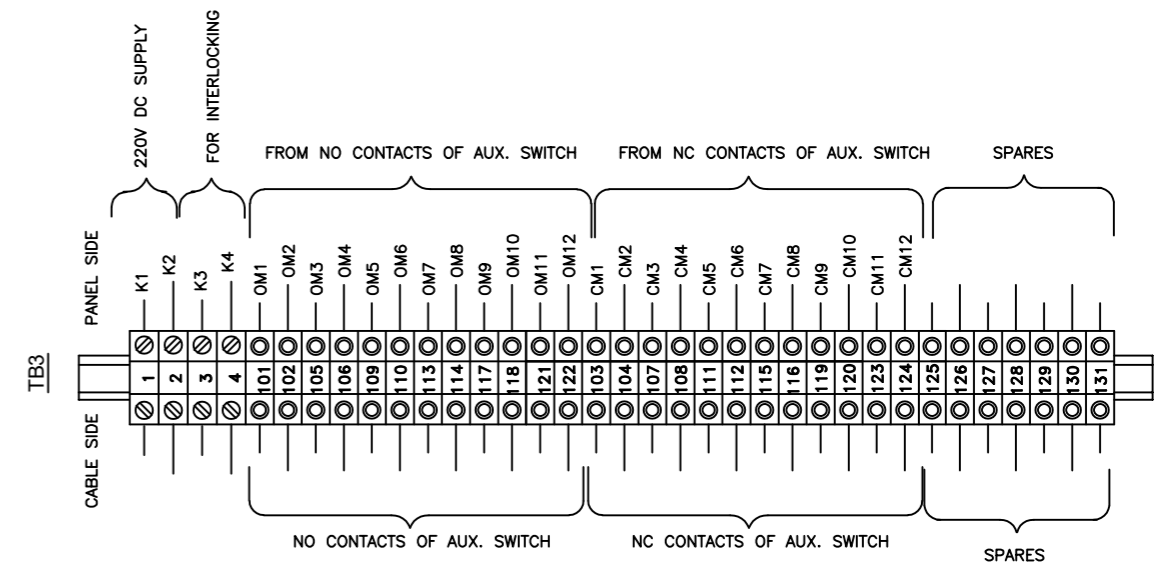

AUX. SWITCH(6NO+6NC) TERMINAL BLOCK DETAILS

Drawing approval subject to valid vendor registration

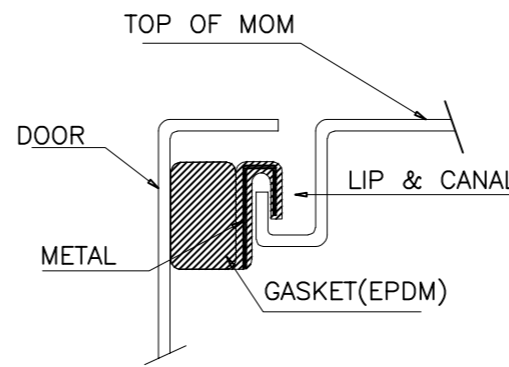

SECTIONAL VIEW OF DOOR GASKET

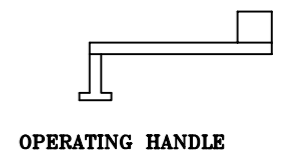

OPERATING HANDLE

15	RAIN CANOPY
14	FIXING BRACKET (MS HDG)
13	FUSES FOR CONTROL SUPPLY(5A)
12	PUSH BUTTON
11	PROVISION FOR PADLOCK
10	Solenoid Coil
9	REDUCTION GEAR
8	CABLE GLAND FIXING PLATE (W/O GLANDS)
7	EARTH TERMINAL(2 nos. M10 size)
6	TERMINAL BLOCK (CTS4UN)
5	AUXILIARY SWITCH
4	GASKET (EPDM RUBBER)
3	CUBICLE (3MM AL SHEET)
2	FLANGE (14 HOLES-10MM THK-MS HDG)
1	OPERATING SHAFT
PT.	DESCRIPTION
PART LIST	

CHIEF ENGINEER/PROJECTS
APTRANSCO/VS/VIJAYAWADA

NOTES

- All dimensions are in 'mm'
- Cubicle will be painted to the shade no. 631 IS:5
- Always keep the drive in upright position
- Degree of protection :IP55
- Net weight of the box-35 Kgs(approx)
- Tolerances as per GA drawing
- Internal wiring will be done with 2.5 sq.mm cu. stranded conductor & 20% spare terminals will be provided

DRN	YVG	04.06.22	SWITCHGEAR MANUFACTURING COMPANY GANDRAJAPALLE, CHITTOOR DIST, A.P, INDIA.
CHKD	VK	04.06.22	
APPD	OJA	04.06.22	TITLE
DEPT	SIGN	DATE	GENERAL ARRANGEMENT OF
			MANUAL OPERATING MECHANISM FOR DISCONNECTOR
SC: NTS	Paper size	A3	DRG.NO. S T D - 1 4 5 0 0 0 9
			SHEET 1 OF 1
			REV. 0

NOTE:- THIS COMPLETE SET OF DRAWINGS ARE REPRESENTATIVE OF THE LATEST TYPE TEST REPORT AND PROPRIETARY DESIGN, RESEARCH & DEVELOPMENT OF SWITCHGEAR MANUFACTURING COMPANY PVT. LTD. GANDRAJAPALLE. THE DESIGNS SHALL NOT BE REPRODUCED WITHOUT WRITTEN CONSENT OF SWITCHGEAR MANUFACTURING COMPANY PVT. LTD. GANDRAJAPALLE.

NOTE: 1. Drawings Approval subject to valid type test reports, to be checked during acceptance tests.
 2. For EPC contractors only.

				78
				765
REV	DATE	CHANGES MADE	SIG	

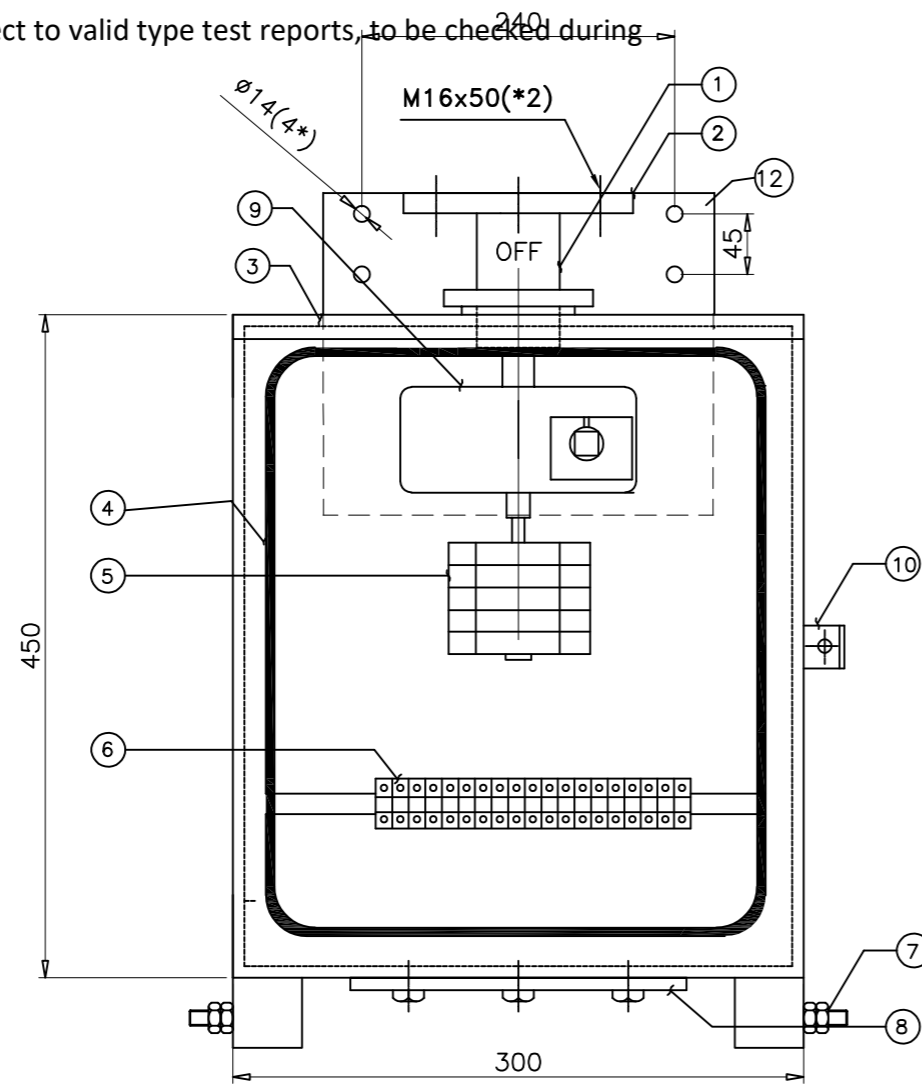

ELEVATION

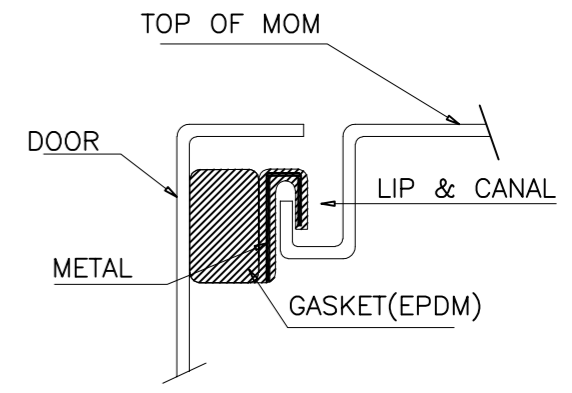
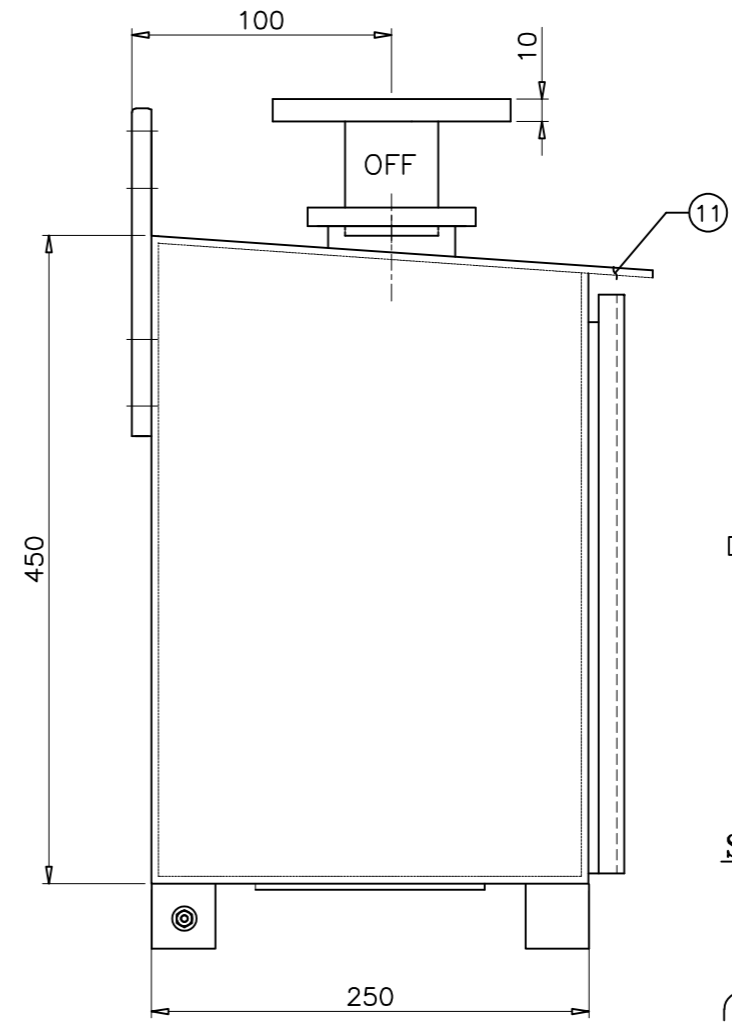

SECTIONAL VIEW OF DOOR GASKET

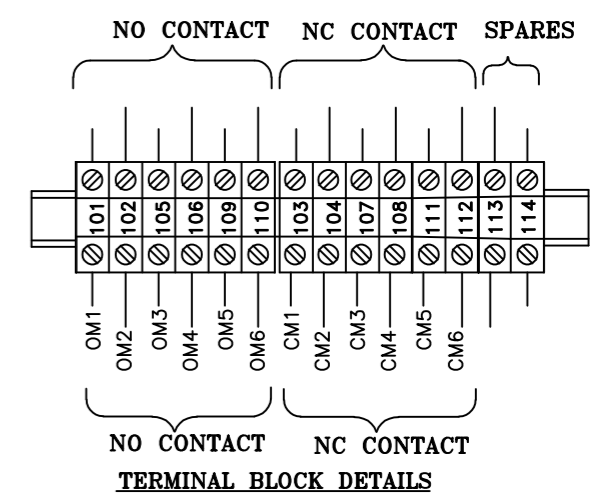

TERMINAL BLOCK DETAILS

CHIEF ENGINEER/PROJECTS
APTRANSCO/VS/VIJAYAWADA

Drawing approval subject to valid vendor registration

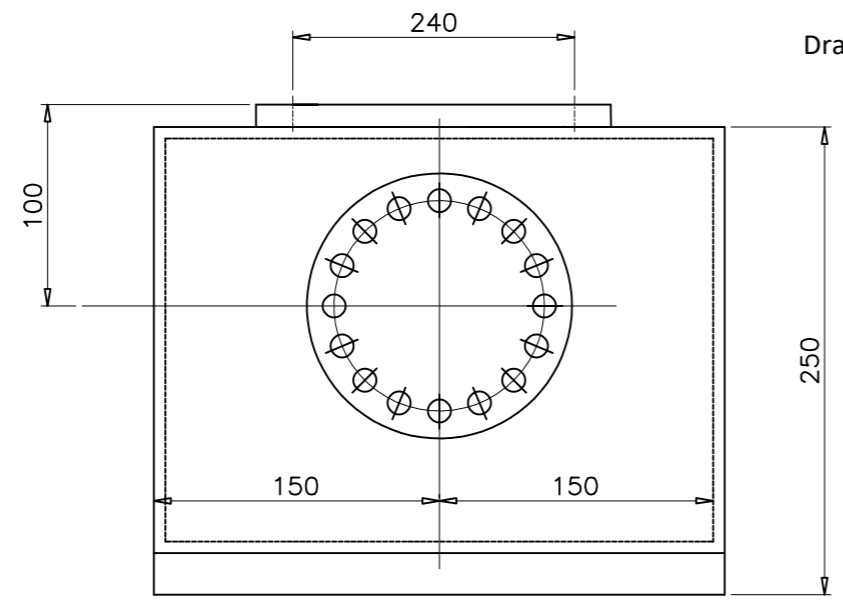

PLAN

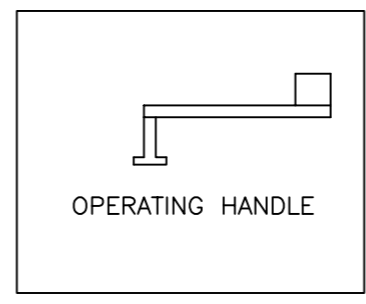

OPERATING HANDLE

PART LIST

1. Operating shaft
2. Flange-I (14 Holes-10MM THK-MS HDG)
3. Cubicle(3mm Al. Sheet)
4. Gasket (EPDM Rubber)
5. Aux.switch (3NO+3NC)
6. Terminal block (CTS4UN)
7. Earthing terminal(2 nos.M10 size)
8. Cable gland Fixing Plate (W/o Glands)
9. Reduction Gear
10. Provision for Pad Lock
11. Rain Canopy
12. FIXING BRACKET (MS HDG)

NOTES

1. All dimensions are in 'mm'
2. Cubicle will be painted to the shade no. 631 IS:5
3. Always keep the drive in upright position
4. Degree of protection :IP55
5. Net weight of the box-35 Kgs(approx)
6. Tolerances as per GA drawing
7. Internal wiring will be done with 2.5 sq.mm cu. stranded conductor & 20% spare terminals will be provided

DRN	YVG	04.06.22	SWITCHGEAR MANUFACTURING COMPANY GANDRAJUPALLE, CHITTOOR DIST, A.P, INDIA.
CHKD	VK	04.06.22	
APPD	OJA	04.06.22	
DEPT	SIGN	DATE	
Paper size SC: NTS A3			TITLE GENERAL ARRANGEMENT OF MANUAL OPERATING MECHANISM FOR EARTH SWITCH
DRG.NO. S T D - 1 4 5 0 0 1 0			SHEET 1 of 1
			REV. 0

NOTE:- THIS COMPLETE SET OF DRAWINGS ARE REPRESENTATIVE OF THE LATEST TYPE TEST REPORT AND PROPRIETARY DESIGN, RESEARCH & DEVELOPMENT OF SWITCHGEAR MANUFACTURING COMPANY PVT. LTD. GANDRAJUPALLE. THE DESIGNS SHALL NOT BE REPRODUCED WITHOUT WRITTEN CONSENT OF SWITCHGEAR MANUFACTURING COMPANY PVT. LTD. GANDRAJUPALLE.

NOTE: 1. Drawings Approval subject to valid type test reports, to be checked during acceptance tests.
2. For EPC contractors only.

1. Minimum 300mm plinth shall be maintained for CT/PT/CVT/Isolators/IV/LA/Breakers in the substation during foundation works to ensure safe live to ground clearance per IE rules.
2. Since the supply of terminal connectors is not in the scope of manufacturer as mentioned in the drawings. The EPC contractor shall be instructed to supply the same line with CT/PT/CVT/Isolator/IVT/LA/Breaker's requirement and compatibility.

			80
			765
REV	DATE	CHANGES MADE	SIG

SWITCHGEAR MANUFACTURING COMPANY
 GANDRAJUPALLE, CHITTOR DIST, A.P., INDIA.

CUSTOMER TRANSMISSION CORPORATION OF ANDHRA PRADESH LIMITED

SL.No.	(*)	TYPE	DBR
VOLTAGE (kV)	145	CURRENT (Amps)	800
STC (kA-sec-kAp)	31.5-1-78.75	IMPULSE (kVp)	650
DC VOLTAGE (V)	220	PF VOLTAGE (kV)	275
OPERATING DRIVE	MANUAL	FREQUENCY (Hz)	50
YEAR	(*)		

FOR DISCONNECTOR

SWITCHGEAR MANUFACTURING COMPANY
 GANDRAJUPALLE, CHITTOR DIST, A.P., INDIA.

CUSTOMER TRANSMISSION CORPORATION OF ANDHRA PRADESH LIMITED

SL.No.	(*)	TYPE	VB
VOLTAGE (kV)	145	FREQUENCY (Hz)	50
STC (kA-sec-kAp)	31.5-1-78.75	YEAR	(*)
OPERATING DRIVE	MANUAL		

FOR EARTH SWITCH

(**) TO BE MARKED AT THE TIME OF MANUFACTURING

NOTE:

1. ALL DIMENSIONS ARE IN MM
2. MATERIAL : ALUMINIUM ALLOY
3. TOLERANCE AS PER GA DRAWING
4. LETTER ITCHED ON BLACK BACKGROUND

Drawing approval subject to valid vendor registration

CHIEF ENGINEER/PROJECTS
APTRANSCO/VS/VIJAYAWADA

DRN	YVG	04.06.22	SWITCHGEAR MANUFACTURING COMPANY
CHKD	VK	04.06.22	
APPD	OJA	04.06.22	GANDRAJUPALLE, CHITTOOR DIST, A.P., INDIA.
DEPT	SIGN	DATE	
SC: NTS			TITLE
Paper size A3			NAME PLATE DETAILS
DRG.NO. S T D - 1 4 5 0 0 1 2			FOR 145KV DBR DISCONNECTOR
			SHEET 1 of 1
			REV. 0

CUSTOMER	:	TRANSMISSION CORPORATION OF ANDHRA PRADESH LIMITED
----------	---	--

GUARANTEED TECHNICAL PARTICULARS FOR 145kV DOUBLE BREAK DISCONNECTOR

SL. No	Description	Unit	Particulars
1.	Manufacturer's Name & Address of manufacture		Switchgear Manufacturing Company Pvt. Ltd, Gandrajupalle, Chittoor Dist
2.	Type Designation		Horizontal Double Break, DBR
3.	Applicable Standard		IS: 9921 (Part I to V) / IEC: 62271-102
4.	Rated voltage	(kV)	145
5.	Rated Frequency	(Hz)	50
6.	Outdoor / Indoor		Outdoor
7.	Whether all three poles are ganged together mechanically / electrically		Mechanically ganged
8.	Rated normal current		
	a) Under normal condition as per IS/ IEC	(Amps)	800Amps
	b) Under site conditions	(Amps)	800
9.	Rated short time withstand current for 1 sec. for Isolator & Earth switch	(kA rms)	31.5
10.	Rated peak withstand short circuit current for Isolator & Earth switch	kAp	78.75
11.	Rated short circuit making current	KA	For No-load operated Isolator making current is not applicable. But shall carry peak short circuit current of 78.75kAp
12.	Rated Magnetizing current / Capacitive current make/break capacity at 0.15% p.f.	(Amp)	0.7 Amps at 0.15 Pf (Assigned value)
13.	Temperature rise over ambient temperature 50°C at site corresponding to		
	a) Maximum continuous current	(° C)	Within 55 °C
	b) Short time current	(° C)	
14.	Rated Insulation level		
	a) 1.2/50 microsecond lightning impulse withstand voltage (+ve or -ve polarity)		
	i) To earth	KV(peak)	± 650
	ii) Across the open Isolator	KV(peak)	
	- One terminal lightning Impulse		± 750
	- Opposite terminal power frequency		Not Applicable
	b) 250 / 2500 microsecond switching impulse withstand voltage		
	i) To earth	KV(peak)	Not Applicable
	ii) Across the open Isolator		
	- One terminal lightning Impulse	KV(peak)	Not Applicable
	- Opposite terminal power frequency	KV(peak)	Not Applicable
	c) One minute power frequency withstand voltage		
	i) To earth	KV (rms)	275
	ii) Across the terminals of open Isolator	KV (rms)	315
15.	Corona extinction voltage	KV (rms)	105
16.	Radio Interference voltage at 0.5 MHz and 2 MHz at 92 kV (rms)	(micro-volt)	500 mV at 92 kV (rms)

7654774/2023/EEMRT-ENE51 For EPC contractors only.
SWITCHGEAR MANUFACTURING COMPANY PVT. LTD

CUSTOMER	:	TRANSMISSION CORPORATION OF ANDHRA PRADESH LIMITED	
17.	Rated mechanical terminal loads		
	a) Longitudinal (or straight)	N	500
	b) Transverse (or cross)	N	170
18.	Total operating time		
	a) Opening time	(Sec.)	12 sec. or less
	b) Closing time	(Sec.)	12 sec. or less
19.	Main contacts (Fixed and Moving) of Isolator & Earth switch		
	a) Type		Main switch: High Pressure, Reverse Loop, Pressure reliving Type with Turn & Twist Design Earth switch: Slide-in-contact
	b) Material		Hard Drawn Electrolytic copper (HDEC)
	c) Whether contacts silver plated		Yes (Contact surface)
	d) Thickness of silver coating	microns	15 microns
	e) Contact area	mm ²	Line Contact
	f) Contact pressure	(Kg/ mm ²)	4kg/cm ² per Finger
	g) Current density(at minimum cross section of switch blade)		
	(i) Moving blade (Cu)	A/mm ²	1.87
	(ii) Terminal pad (Al)	A/mm ²	0.88
	(iii) Contacts (Cu)	A/mm ²	1.56
	(iv) Terminal connectors (Al)	A/mm ²	1.0
	h) No. of operations which the Isolator can make without deterioration of contacts	Nos.	1000 (min)
20.	AUXILIARY CONTACTS		
	a) MAIN ISOLATOR		
	(i) Total number of 'NO'(for Purchaser's use)	Nos.	6
	(ii) Total number of 'NC'(for Purchaser's use)	Nos.	6
	(iii) Rated voltage	(Volts)	220V DC
	(iv) Rated continuous current	(Amps)	10A
	(v) Rated breaking current	(Amps)	2A DC
	b) EARTH SWITCH		
	(i) Total number of 'NO'(for Purchaser's use)	Nos.	3
	(ii) Total number of 'NC'(for Purchaser's use)	Nos.	3
	(iii) Rated voltage	(Volts)	220V DC
	(iv) Rated continuous current	(Amps)	10A
	(v) Rated breaking current	(Amps)	2A DC
	c) Whether arcing contacts provided, and if so, and material used		Yes, M.S. Rod Hot-dip Galvanized
21.	Minimum clearance in air:		
	a) Phase to Phase clearance	mm	3000 (Center to Center)
	b) Phase to Ground clearance	mm	1500(Equal to the height of insulator selected)
	c) Between phases when isolator is open:	mm	2135(Center to Center)
22.	Bearings		
	a) Types of bearings		Deep Groove ball bearing
	b) Locations of bearings		Below the rotating post insulator
	c) Type of lubricant for bearings		Heavy Duty Grease

Drawing approval subject to valid vendor registration

CHIEF ENGINEER/PROJECTS
APTRANSCO/VS/VIJAYAWADA

CUSTOMER	:	TRANSMISSION CORPORATION OF ANDHRA PRADESH LIMITED
----------	---	--

NOTE: 1. Drawings Approval subject to valid type test reports, to be checked during acceptance tests.

2. For EPC contractors only.

23.	Terminal Clamp & Connectors		
	a) Manufacturer's Name		Not in scope of Switchgear Manufacturing Company
	b) Applicable standard		
	c) Material		
	i. Clamp body		
	ii. Bolts & nuts		
	iii. Spring washers		
	d) Rated current	Amp	
	e) Rated terminal load	Kg.	
	f) Weight of clamp complete with hard ware	Kg.	
	g) Radio interference voltage	(micro-volts)	
	h) Corona extinction voltage	kV	
	i) Maximum allowable span for Aluminium Tube with outer diameter of 114.2 mm and inside diameter of 97.18 mm on equipment terminal and with rated fault current and 7 m & 4.5 m phase to phase spacing		
24.	Operating Mechanism		
	a) Name & address of manufacturer		Switchgear Manufacturing Company Pvt. Ltd, Gandrajupalle, Chittoor Dist
	b) Type of operating mechanism		Main switch: Manual (with reduction gear) Earth switch: Manual (with reduction gear)
	c) Whether separate operating mechanism provided for operation of Isolator pole and earthing switch.		Yes
	d) Electrical operation.		
	i) Motor type (AC / DC)		Not Applicable
	ii) Applicable standard		Not Applicable
	iii) Rated - voltage and current, HP		Not Applicable
	iv) Type of enclosure and method of cooling		Not Applicable
	v) Power required for closing and opening operation	Watts	Not Applicable
	vi) Running time for motor for closing and opening operation	(sec.)	Not Applicable
	vii) Control supply for motor (volt), power, consumption	Volt, Amp	Not Applicable
	e) Type of manual operating mechanism for Isolator pole and earth switch.		Main switch & Earth Switch: Reduction gear for smoothly controlled movement during the entire operation cycle.
	f) Force required to operate		25 Kg-m.
	g) Whether padlocking are in included as per the specification		Provision is made
	h) Type of manual device		Torsional
	i) Weight of operating mechanism	kg	30 (Approx)

Drawing approval subject to valid vendor registration

CHIEF ENGINEER/PROJECTS
APTRANSCO/VS/VIJAYAWADA

NOTE: 1. Drawings Approval subject to valid type test reports, to be checked during

7654774/2023/EEMRT-ENE51

Performance tests.

SWITCHGEAR MANUFACTURING COMPANY PVT. LTD

2. For EPC contractors only.

CUSTOMER	:	TRANSMISSION CORPORATION OF ANDHRA PRADESH LIMITED
----------	---	--

25.	Type of interlocking between isolator and earthing switch		Mechanical (Constructional)
	a) Resistance of operating and Interlock coils	kΩ	2
	b) Details of following interlocks provided as per specification		
	i) Mechanical interlock between Isolator and earth switch		Yes
	ii) Electrical interlock for Isolator and earth switch		No
	iii) Electrical interlocking in association with circuit breaker		Yes
	iv) Electrical interlock to bring back all three poles to open position in case any pole fails to close within specified time.		Not Applicable
	v) Provisions to cut-off supply to the motor during manual operation and provision for de-coupling the motor.		Not Applicable
	vi) Electrical scheme to provide remote alarm for pole discrepancy		Not Applicable
	vii) Arrangement provided to prevent electrical or manual operation unless interlock is satisfied.		Yes
26.	A. Tandem Pipe		
	a) Size		32 NB
	b) Class		Class 'B'
	c) Material		G.I. Pipe
	d) Applicable Standard		IS: 1239 (Part I), 1990 & IS: 4736, 1986
	e) Weight of Zinc	(gm/sq.m)	360
	B. Down Pipe		
	a) Size (Internal / External dia)	(mm)	50 NB
	b) Class		Class 'B'
	c) Material		G.I. Pipe
	d) Applicable Standard		IS: 1239 (Part I), 1990 & IS: 4736, 1986
	e) Weight of Zinc	(gm/sq.m)	360
27.	Size and Weight		
	a) Weight of each pole (without Insulators)	Kgs. (Approx.)	Please refer GA drawing
	b) Space requirement i.e. length		
	c) Dimensions		
	(i) 3 Phase Isolator		
	(ii) Isolator -cum-Earthing Switch (mm x mm x mm)	mm	
	d) Size of largest part		
28.	Insulators		Not in scope of Switchgear Manufacturing Company

For Switchgear Manufacturing Company Pvt. Ltd



Authorized Signatory

Drawing approval subject to valid vendor registration

1. Minimum 300mm plinth shall be maintained for CT/PT/CVT/Isolators/IV/LA/Breakers in the substation during foundation works to ensure safe live to ground clearance per IE rules.
2. Since the supply of terminal connectors is not in the scope of manufacturer as mentioned in the drawings. The EPC contractor shall be instructed to supply the same line with CT/PT/CVT/Isolator/IVT/LA/Breaker's requirement and compatibility.