

REPORTS, TO BE CHECKED DURING ACCEPTANCE TESTS
2. FOR EPC CONTRACTS ONLY

NOTES:-

1. MAKE OF BUSHING: IEC/MODERN/ABIL/BHEL/CJI
2. ALL FERROUS PART EXPOSED TO THE ATMOSPHERE SHALL BE PAINTED WITH P.U PAINT SHADE 631 OF IS:5
3. ALL GASKETS SHALL BE FIXED IN PROPERLY MACHINED GROOVES.
4. PRIMARY WINDING SHALL BE BAR TYPE.
5. ALL HARDWARE SHALL BE HOT DIP GALVANIZED.
6. TRANSFORMER OIL AS PER IEC : 60296.
7. ALL GASKETS SHALL BE MADE OF NITRILE BUTYL RUBBER.
8. THE CORES & SECONDARY WINDINGS SHALL BE ENCLOSED IN RIGID ALUMINUM SHELL.

- * TOTAL WEIGHT OF CT:- 260Kgs (APPROX.)
- * QUANTITY OF OIL:- 65 Ltrs (APPROX.)
- * TOTAL CREEPAGE DISTANCE:- 4495 mm. (MINIMUM)

S.No.	DESCRIPTION	MATERIAL	QTY
1	OIL FILLING PORT	M.S	1
2	BELLOW	S.S	1
3	BELLOW DOME	M.S/AL	1
4	OIL LEVEL INDICATOR	BRASS/AL.	1
5	PRIMARY TERMINAL Ø30x80mm	ALUMINUM	1
6	OIL TANK WITH COVER	M.S	1
7	BUSHING FLANGE (CEMENTED)	GI/CI	2
8	BUSHING	PORCELAIN	1
9	BASE	M.S	1
10	SECONDARY TERMINAL BOX	M.S	1
11	LIFTING HOOK	M.S	4
12	EARTHING FLAT 80x50x8THICK.	M.S	2
13	NAME AND RATING PLATE	ALUMINUM	1
14	MOUNTING HOLE, Ø16mm ±2	M.S	4
15	OIL DRAIN PLUG	M.S	1

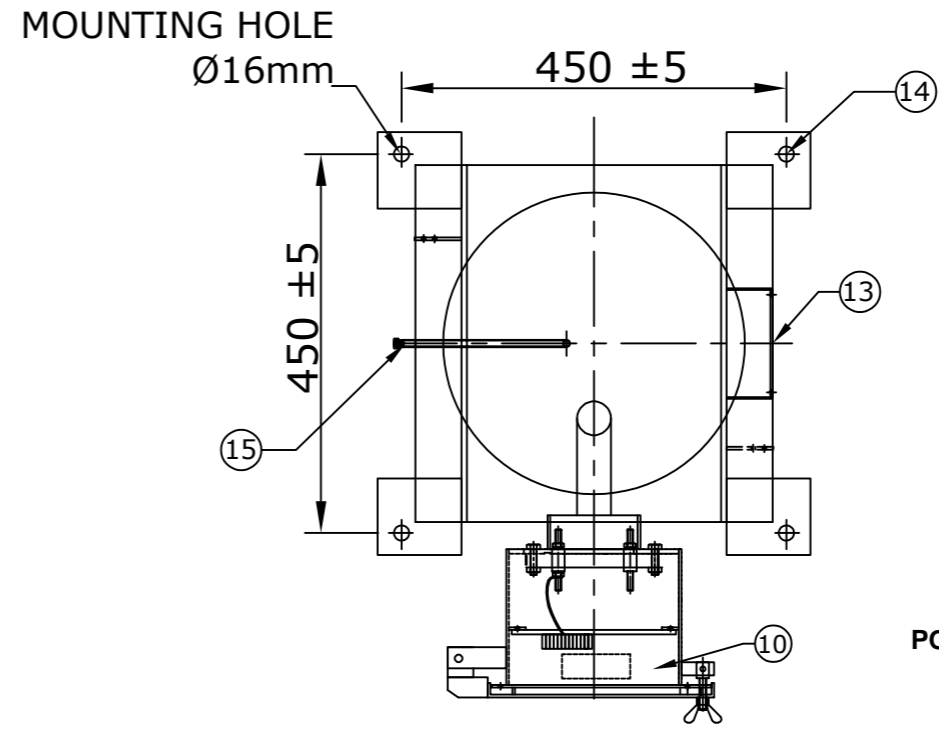
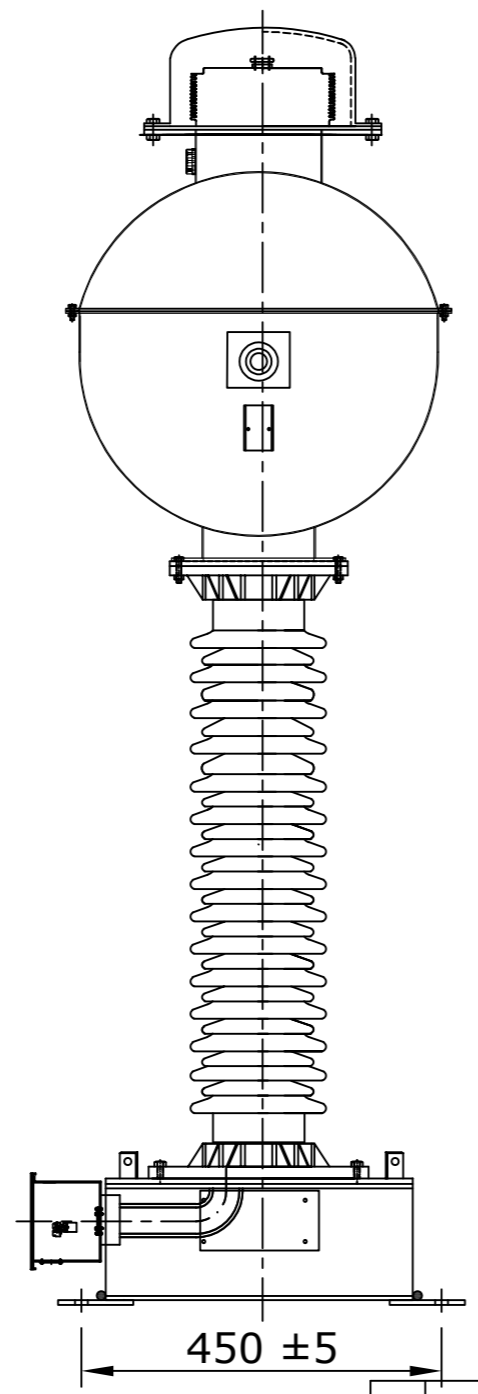
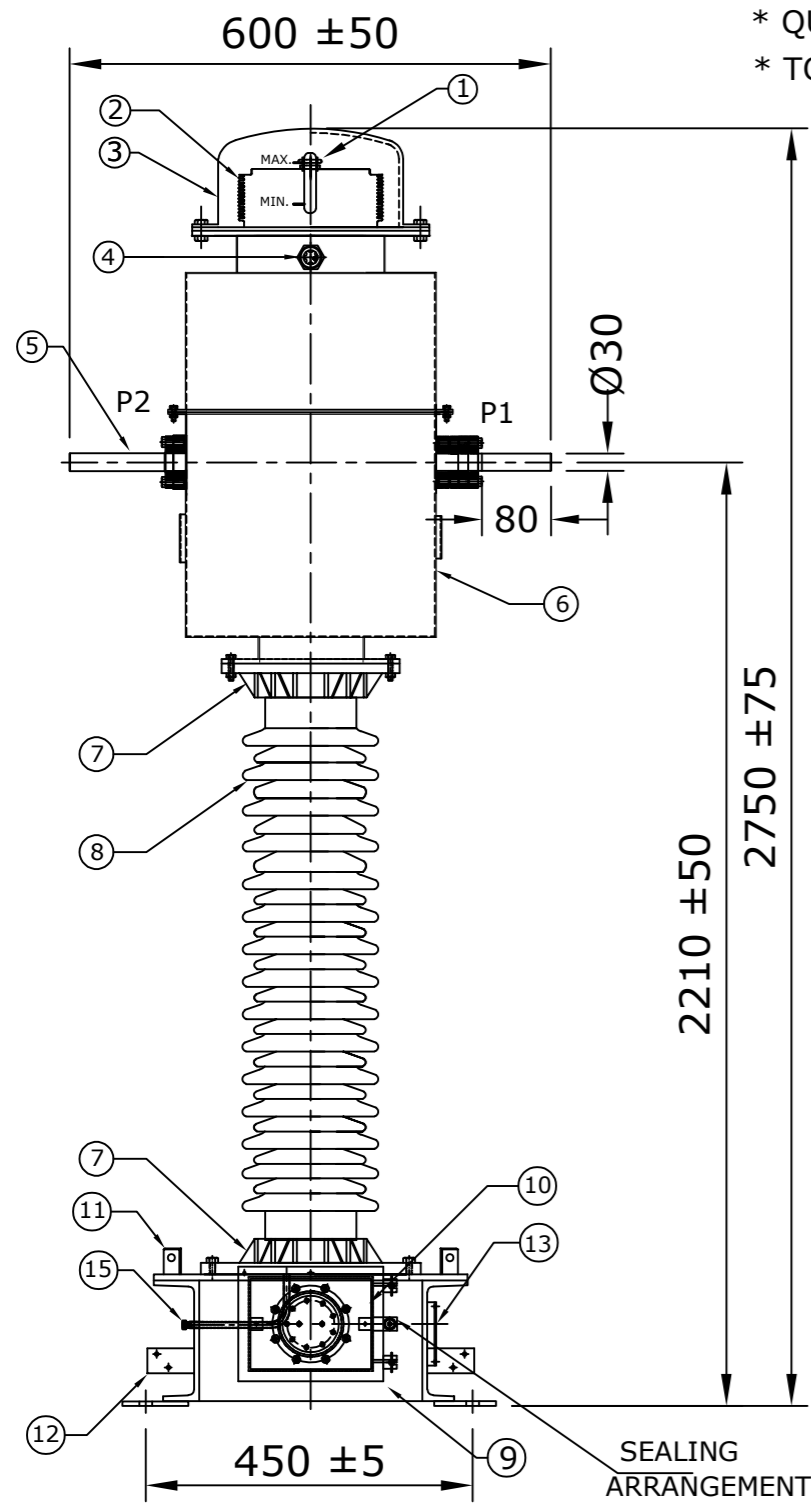
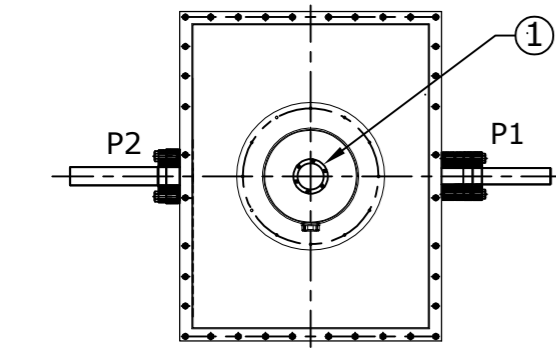

CHIEF ENGINEER
POWER SYSTEMS, PLANNING & DESIGN
APTRANSCO

MOUNTING DETAILS

CLIENT : TRANSMISSION CORPORATION OF ANDHRA PRADESH LIMITED
PROJECT NAME : AS APPLICABLE

UNLESS OTHERWISE SPECIFIED
1. ALL DIMENSIONS ARE IN mm.
2. TOLERANCE WHEREVER NOT INDICATED ±5%

	DATE	NAME	MATERIAL
DGN.	23.06.2021	SPS	AS ABOVE
DRN.	23.06.2021	AKASH	
CHD.	23.06.2021	BLS	
SCALE:	N.T.S		

MEHRU
MEHRU ELECTRICAL & MECHANICAL ENGINEERS (P) LTD.

TITLE :
GENERAL ARRANGEMENT DRAWING FOR 132KV CURRENT TRANSFORMER RATIO:- 300/1A BAR TYPE CT

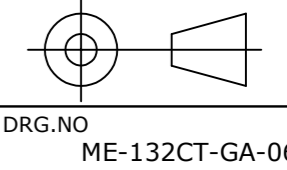

REV.	REVISION DESCRIPTION	DATED INITIALS
R0	FOR APPROVAL	23.06.2021

SHEET No. 1 OF 7

Drawing approval subject to valid vendor registration

NOTE: 1. DRAWING APPROVAL SUBJECT TO VALID TYPE TEST REPORTS, TO BE CHECKED DURING ACCEPTANCE TESTS
2. FOR EPC CONTRACTS ONLY

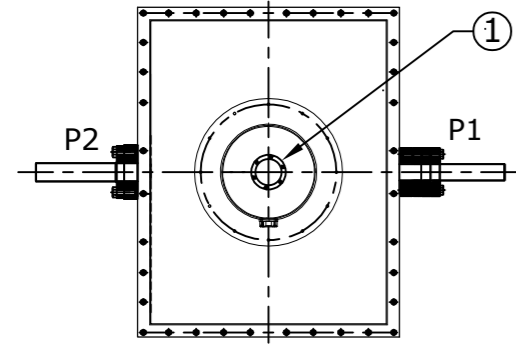

NOTES:-

1. MAKE OF BUSHING: IEC/MODERN/ABIL/BHEL/CJI
2. ALL FERROUS PART EXPOSED TO THE ATMOSPHERE SHALL BE PAINTED WITH P.U PAINT SHADE 631 OF IS:5
3. ALL GASKETS SHALL BE FIXED IN PROPERLY MACHINED GROOVES.
4. PRIMARY WINDING SHALL BE BAR TYPE.
5. ALL HARDWARE SHALL BE HOT DIP GALVANIZED.
6. TRANSFORMER OIL AS PER IEC : 60296.
7. ALL GASKETS SHALL BE MADE OF NITRILE BUTYL RUBBER.
8. THE CORES & SECONDARY WINDINGS SHALL BE ENCLOSED IN RIGID ALUMINUM SHELL.

- * TOTAL WEIGHT OF CT:- 260Kgs (APPROX.)
- * QUANTITY OF OIL:- 65 Ltrs (APPROX.)
- * TOTAL CREEPAGE DISTANCE:- 4495 mm. (MINIMUM)

S.No.	DESCRIPTION	MATERIAL	QTY
1	OIL FILLING PORT	M.S	1
2	BELLOW	S.S	1
3	BELLOW DOME	M.S/AL.	1
4	OIL LEVEL INDICATOR	BRASS/AL.	1
5	PRIMARY TERMINAL Ø30x80mm	ALUMINUM	1
6	OIL TANK WITH COVER	M.S	1
7	SECONDARY TERMINAL	BRASS	---
8	BUSHING	PORCELAIN	1
9	BASE	M.S	1
10	SECONDARY TERMINAL BOX	M.S	1
11	LIFTING HOOK	M.S	4
12	EARTHING FLAT 80x50x8THICK.	M.S	2
13	NAME AND RATING PLATE	ALUMINUM	1
14	MOUNTING HOLE, Ø16mm±2	M.S	4

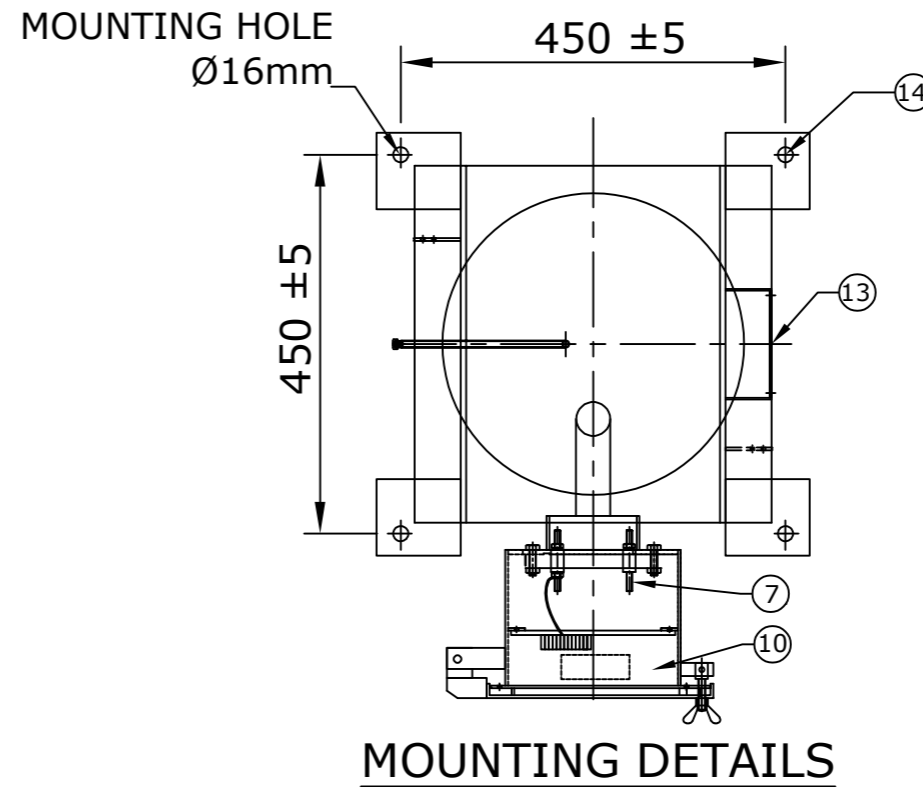
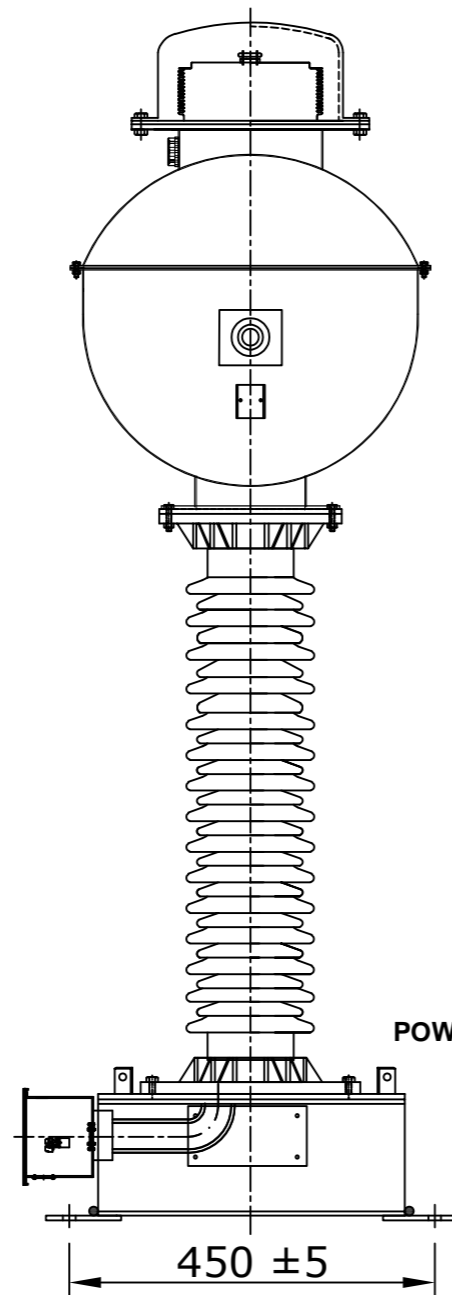
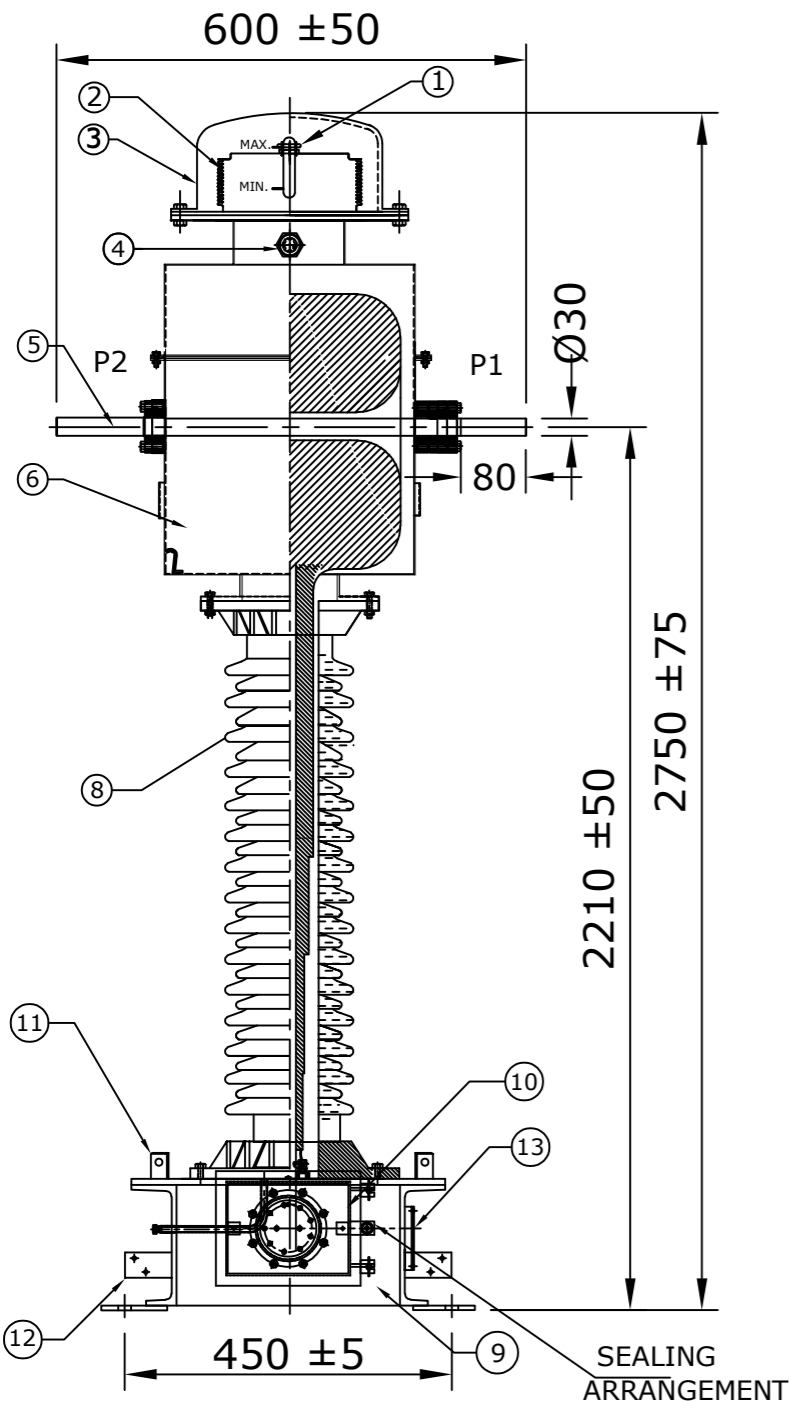

**CHIEF ENGINEER
POWER SYSTEMS, PLANNING & DESIGN
APTRANSCO**

CLIENT : TRANSMISSION CORPORATION OF ANDHRA PRADESH LIMITED
PROJECT NAME : AS APPLICABLE

UNLESS OTHERWISE SPECIFIED	DATE	NAME	MATERIAL
1. ALL DIMENSIONS ARE IN mm.	DGN. 23.06.2021	SPS	AS ABOVE
2. TOLERANCE WHEREVER NOT INDICATED ±5%	DRN. 23.06.2021	AKASH	
	CHD. 23.06.2021	BLS	
SCALE: N.T.S			

MEHRU
MEHRU ELECTRICAL & MECHANICAL ENGINEERS (P) LTD.

TITLE :
SECTIONAL ARRANGEMENT DRAWING FOR 132kV CURRENT TRANSFORMER RATIO:- 300/1A BAR TYPE CT

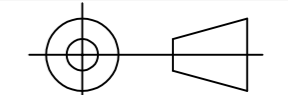

DRG.NO
ME-132CT-SE-06

REV.	REVISION DESCRIPTION	DATED INITIALS
R0	FOR APPROVAL	23.06.2021

SHEET No.
2 OF 7

Drawing approval subject to valid vendor registration

NOTE: 1. DRAWING APPROVAL SUBJECT TO VALID TYPE TEST REPORTS, TO BE CHECKED DURING ACCEPTANCE TESTS
2. FOR EPC CONTRACTS ONLY

MEHRU LIVE TANK CURRENT TRANSFORMER
MADE TO IS: 16227

HIGHEST SYSTEM VOLTAGE	145 kV	INSULATION LEVEL	275/650 kV
RATED S.T.C	31.5kA for 1 second	RATED FREQUENCY	50Hz
NOMINAL SYSTEM VOLTAGE	132 kV	CORE 1	
RATIO	PRIMARY(Amp)	300	
	SECONDARY(Amp)	1	
SECONDARY TERMINALS	1S1-1S2		
RATED BURDEN IN V.A	5 VA		
ACCURACY CLASS	0.2S		
ALF / ISF	≤5		
Min Knee point voltage	----		
Max Rct @ 75° C	----		
Max Iext @ Vk	----		
YEAR OF MANUFACTURE	2021	SERIAL NO.	

RATED CONTINUOUS THERMAL CURRENT: 120% OF THE RATED PRIMARY CURRENT
 * QUANTITY OF OIL:- 65 Ltrs (APPROX.) * TOTAL WEIGHT OF CT:- 260Kgs (APPROX.)
 MADE IN INDIA BY * TOTAL CREEPAGE DISTANCE:- 4495 mm. (MINIMUM)
MEHRU ELECTRICAL AND MECHANICAL ENGINEERS (P) LTD.
 SP2/180,RIICO INDUSTRIAL AREA,KEHRANI, BHIWADI - RAJASTHAN - 301019

SUITABLE FOR HOT LINE WASHING

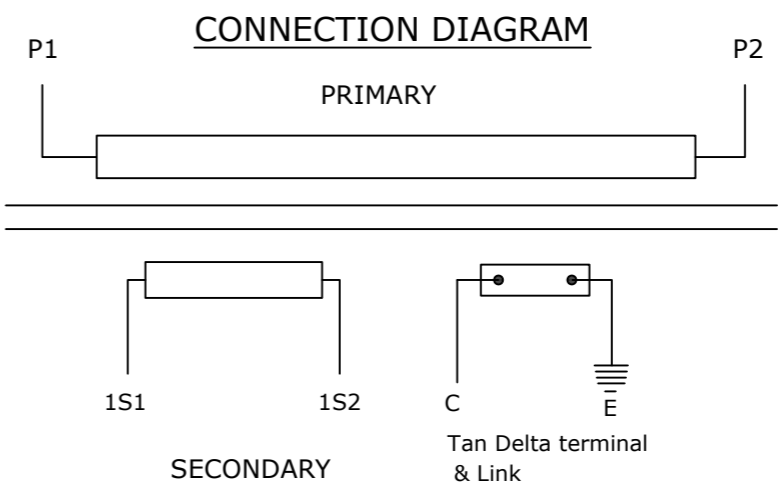

FOR RATIO	PRIMARY CONNECTION	SECONDARY CONNECTION
		CORE I
300/1A	P1-P2	1S1-1S2

CAUTION
 I. Secondary terminals should be short circuited before the burden is disconnected.
 II. Tan delta terminal 'C' must be shorted to be earth when operation
 III. Do not remove earth link when in operation

105 ±15

225 ±20

NOTES:-

1. THICKNESS OF RATING PLATE 1.2 mm
2. MATERIAL OF NAME PLATE SHALL BE AL. ANODIZED.
3. SERIAL NUMBER SHALL BE ENGRAVING BEFORE THE DISPATCH.

- * PRIMARY WINDING AREA : 707 sq.mm
- * CURRENT DENSITY : 0.51 A/sq.mm
- * No. OF PRIMARY TURN: 1
- * No. OF SECONDARY TURN:300

CHIEF ENGINEER
POWER SYSTEMS, PLANNING & DESIGN
APTRANSCO

CLIENT : TRANSMISSION CORPORATION OF ANDHRA PRADESH LIMITED PROJECT NAME : AS APPLICABLE			
UNLESS OTHERWISE SPECIFIED 1. ALL DIMENSIONS ARE IN mm. 2. TOLERANCE WHEREVER NOT INDICATED ±5%	DGN.	23.06.2021	SPS
	DRN.	23.06.2021	AKASH
	CHD.	23.06.2021	BLS
	SCALE:	N.T.S	
TITLE :			 MEHRU ELECTRICAL & MECHANICAL ENGINEERS (P) LTD.
NAME PLATE DRAWING FOR 132kV CURRENT TRANSFORMER RATIO:- 300/1A BAR TYPE CT			
SHEET No. 3 OF 7			DRG.NO ME-132CT-NP-06

Drawing approval subject to valid vendor registration

RO	FOR APPROVAL	23.06.2021
REV.	REVISION DESCRIPTION	DATED INITIALS

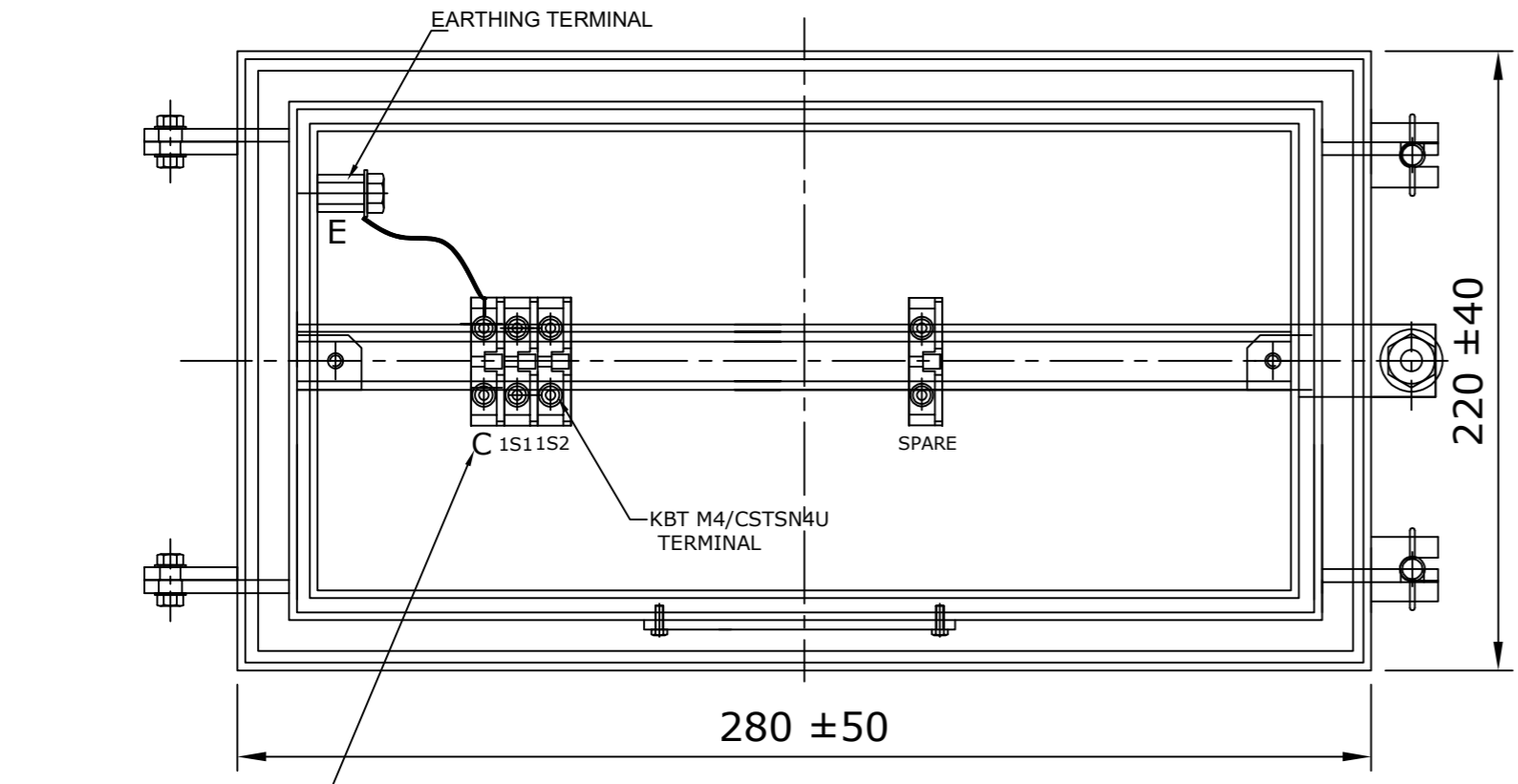

FRONT VIEW

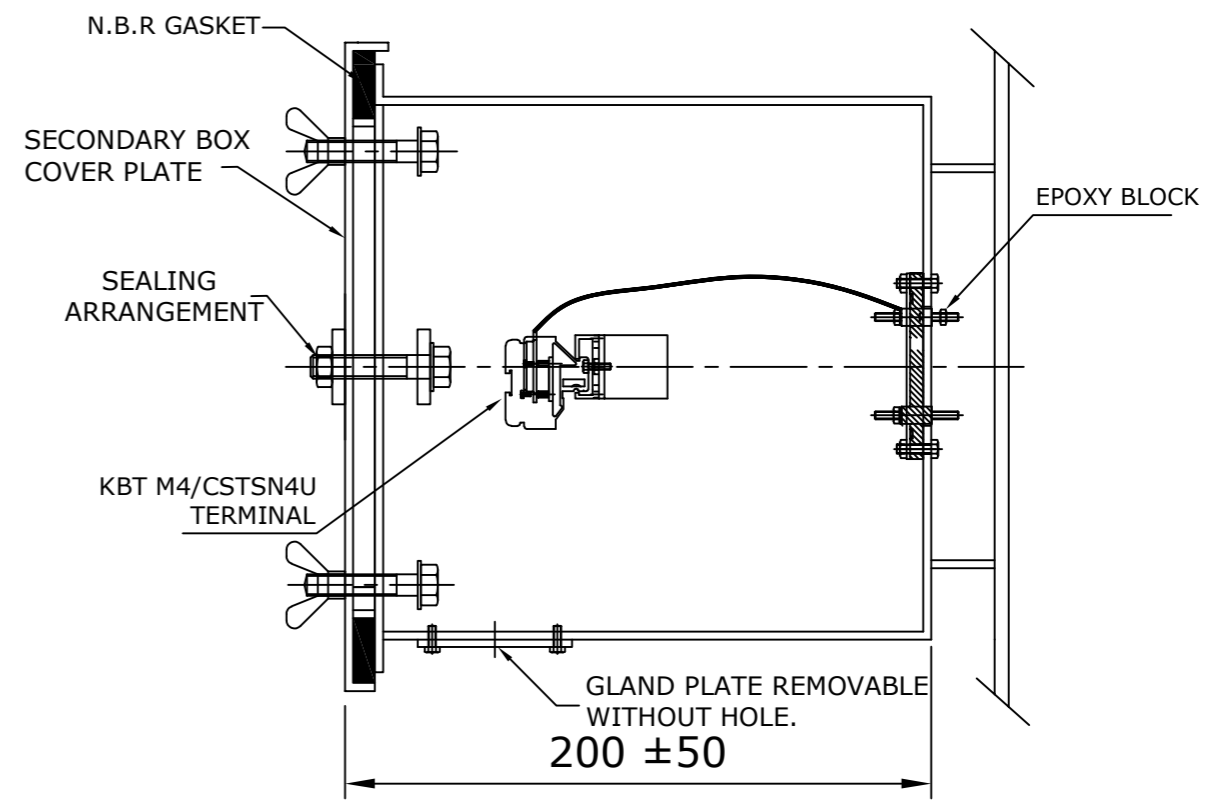

SIDE VIEW

C&TAN DELTA TESTING TERMINAL

C : TAN DELTA TESTING TERMINAL
E : EARTHING TERMINAL

NOTES:-

1. SECONDARY TERMINAL BOX SHALL BE PROVIDE GLAND PLATE REMOVABLE WITHOUT HOLE.
2. SECONDARY TERMINAL BOX SHALL BE PROVIDED WITH COVER.
3. M.S SHEET THICKNESS FOR TERMINAL BOX 3.0mm & FOR COVER 2.0mm.
4. MATERIAL OF GASKET : NITRILE BUTYL RUBBER GASKET.
5. DEGREE OF PROTECTION : IP 55
6. 20% SPARE TERMINAL SHALL BE PROVIDED.

NOTE: 1. DRAWING APPROVAL SUBJECT TO VALID TYPE TEST REPORTS, TO BE CHECKED DURING ACCEPTANCE TESTS
2. FOR EPC CONTRACTS ONLY

Drawing approval subject to valid vendor registration

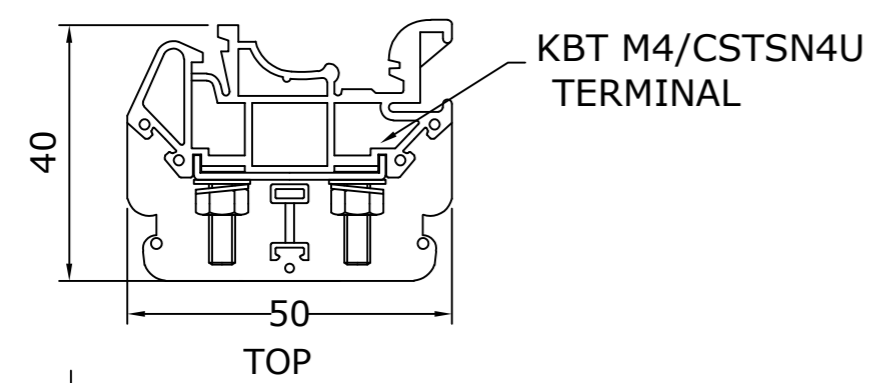

TOP

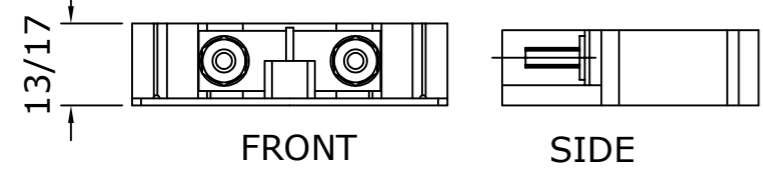

FRONT

SIDE

MATERIAL: POLYAMIDE
MAKE: ELMEX/CONNECTWELL

TERMINAL (DETAIL)

**CHIEF ENGINEER
POWER SYSTEMS, PLANNING & DESIGN
APTRANSCO**

REV.	REVISION DESCRIPTION	DATED INITIALS
R0	FOR APPROVAL	23.06.2021

CLIENT : TRANSMISSION CORPORATION OF ANDHRA PRADESH LIMITED PROJECT NAME : AS APPLICABLE				MEHRU MEHRU ELECTRICAL & MECHANICAL ENGINEERS (P) LTD.
UNLESS OTHERWISE SPECIFIED	DATE	NAME	MATERIAL	
1. ALL DIMENSIONS ARE IN mm.	DGN. 23.06.2021	SPS	M.S	
2. TOLERANCE WHEREVER NOT INDICATED ±5%	DRN. 23.06.2021	AKASH		
	CHD. 23.06.2021	BLS		
SCALE: N.T.S				
TITLE : SECONDARY TERMINAL BOX DRAWING FOR 132kV CURRENT TRANSFORMER RATIO:- 300/1A BAR TYPE CT				
SHEET No. 4 OF 7				DRG.NO ME-132CT-STB-06

NOTE: 1. DRAWING APPROVAL SUBJECT TO VALID TYPE TEST
4714698/2021/EEMRT-ENE51 REPORTS, TO BE CHECKED DURING ACCEPTANCE TESTS
 2. FOR EPC CONTRACTS ONLY

Guaranteed Technical Particulars for 132kV Current Transformer			
Sl. No.	Item Description	Unit	GTP as per Bid
E	CURRENT TRANSFORMER		
1	Make		Mehru Electrical & Mechanical Engineers (P) Ltd, Bhiwadi, (Raj), Inida
2	Type and Designation		Outdoor, Oil Cooled Live Tank Type, Current Transformer
3	Applicable standards Drawing approval subject to valid vendor registration		IS 16227
4	Class		A
5	Rated Voltage	132 kV	132 kV
6	Rated Primary current	Amps	300A
7	Rated Secondary current	Amps	1
8	Rated output (Burden)	VA	Core:-1 5VA
9	Rated output at 0.8 lag. p.f.	VA	N/A
10	Class of accuracy		Core:1 - 0.2S
11	Accuracy limit factor		N/A
12	Knee point voltage @highest tap	Volts	N/A
13	CT Resistance of secondary winding corrected to 75 deg.C @highest tap	Ohms	N/A
14	Magnetising current at knee-voltage point @highest tap		N/A
15	secondary limiting voltage	kV	As per IS 16227
16	Instrument security factor for winding meant for metering		Core-1-≤ 5
17	One minute Power Frequency withstand test voltage of		
a)	Primary winding	kV (rms)	275
b)	Secondary winding	kV (rms)	3
18	Impulse wave withstand voltage of primary winding	kV (peak)	650
19	One minute dry P.F. withstand voltage of primary winding	kV (rms)	275

NOTE: 1. DRAWING APPROVAL SUBJECT TO VALID TYPE TEST
4714698/2021/EEMRT-ENE51 REPORTS, TO BE CHECKED DURING ACCEPTANCE TESTS

2. FOR EPC CONTRACTS ONLY

20	Creepage distance	mm	31mm/kV i.e. 4495mm (Min.)
21	Rated continuous thermal current	Amps	120% of rated primary current
22	Ratios available at highest taps		Yes
23	Rated short time thermal current	kA (rms)	31.5 kA
24	Rated time for above	Sec.	1
25	Rated dynamic current for primary	kA (Peak)	78.75
26	Class of insulation		A
27	Max. Temperature rise over ambient of 50 deg.C at any part of oil	deg.C	50c max
28			
b)	Radio interference voltage		As per IS 16227 Clause 6.11.2 <2500uV
c)	Partial discharge level		<10 pC at Um & <5 pc at 1.2Um/√3
29	Temp. rise after passing short time thermal current for one second	deg.C	50c max
30	Current density in primary winding at		
a)	Normal rating		0.51 Amp/sqmm (max)
b)	Short time rating of 1 Sec.		44.55 Amp/sqmm(max.)
c)	Dynamic rating		111.38 Amp/sqmm (max.)
31	Type of primary winding		Aluminum
32	No. of primary turns		1
33	No. of secondary turns		300
34	Flux density at knee point		1.4 Tesla
35	Radio interference voltage	(micro volts)	
a)	with terminal connector mountd		<2500uV
b)	under test condition		<2500uV
36	Variation in ratio and phase angle error due to variation in		

NOTE: 1. DRAWING APPROVAL SUBJECT TO VALID TYPE TEST

4714698/2021/EEMRT/ENE5.1 TO BE CHECKED DURING ACCEPTANCE TESTS

2. FOR EPC CONTRACTS ONLY

a)	Voltage by 1%		N/A
b)	Frequency by 1 Hz.		N/A
37	Mounting details		450±5 x 450±5 mm
38	Source/grade of oil and standard with which it complies		EHV Grade Transformer Oil as per IS 335/IEC 60296 of any reputed make
39	Quantity of insulating oil	Litres	65 Ltr Approx
40	Weight of Oil	kg	52 kgs Approx
41	Total Weight including Oil	kg	260kG Approx
42	Overall dimensions (mm)		2750±75 x 600±50 x 450±5 mm
43	Wheather sealed (if so, type of sealing)		Yes, By SS BELLOW

**CHIEF ENGINEER
POWER SYSTEMS, PLANNING & DESIGN
APTRANSCO**

Drawing approval subject to valid vendor registration