

**NOTES:-**

1. MAKE OF BUSHING: IEC/MODERN/ABIL/BHEL/CJI
2. ALL FERROUS PART EXPOSED TO THE ATMOSPHERE SHALL BE PAINTED WITH P.U PAINT SHADE 631 OF IS:5
3. ALL GASKETS SHALL BE FIXED IN PROPERLY MACHINED GROOVES.
4. PRIMARY WINDING SHALL BE WOUND TYPE.
5. ALL HARDWARE SHALL BE HOT DIP GALVANIZED.
6. TRANSFORMER OIL AS PER IEC : 60296.
7. ALL GASKETS SHALL BE MADE OF NITRILE BUTYL RUBBER.
8. THE CORES & SECONDARY WINDINGS SHALL BE ENCLOSED IN RIGID ALUMINUM SHELL.

- \* TOTAL WEIGHT OF CT:- 260Kgs (APPROX.)
- \* QUANTITY OF OIL:- 65 Ltrs (APPROX.)
- \* TOTAL CREEPAGE DISTANCE:- 3625 mm. (MINIMUM)

NOTE: 1. DRAWING APPROVAL SUBJECT TO VALID TYPE TEST REPORTS, TO BE CHECKED DURING ACCEPTANCE TESTS  
2. FOR EPC CONTRACTS ONLY

S.No.	DESCRIPTION	MATERIAL	QTY
1	OIL FILLING PORT	M.S	1
2	BELLOW	S.S	1
3	BELLOW DOME	M.S/AL.	1
4	OIL LEVEL INDICATOR	BRASS/AL.	1
5	PRIMARY TERMINAL Ø30x80mm	COPPER NICKEL PLATED	2
6	OIL TANK WITH COVER	M.S	1
7	BUSHING FLANGE (CEMENTED)	GI/CI	2
8	BUSHING	PORCELAIN	1
9	BASE	M.S	1
10	SECONDARY TERMINAL BOX	M.S	1
11	LIFTING HOOK	M.S	4
12	EARTHING FLAT 80x50x8 mm. Thick	M.S	2
13	NAME AND RATING PLATE MOUNTING HOLE, 16mm ±2	AL. ANODIZED	1
14		M.S	4
15	OIL DRAIN PLUG	M.S	1

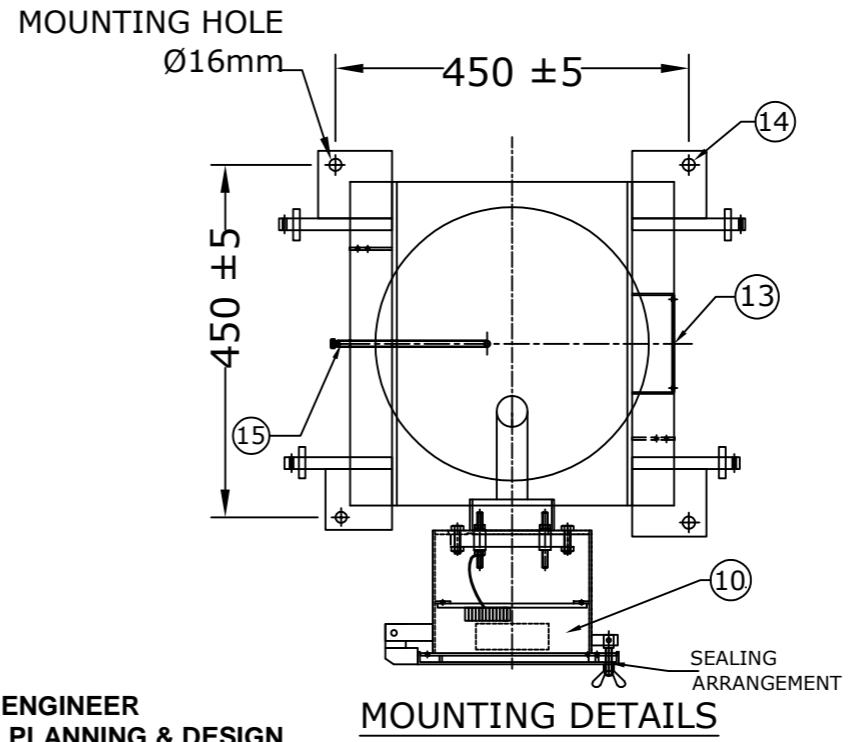
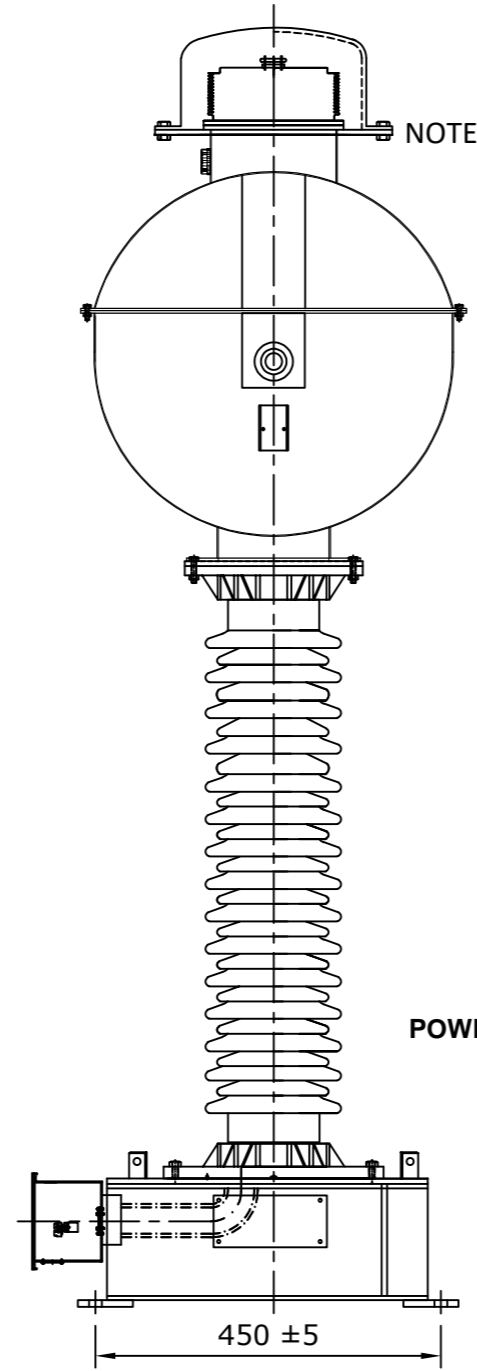
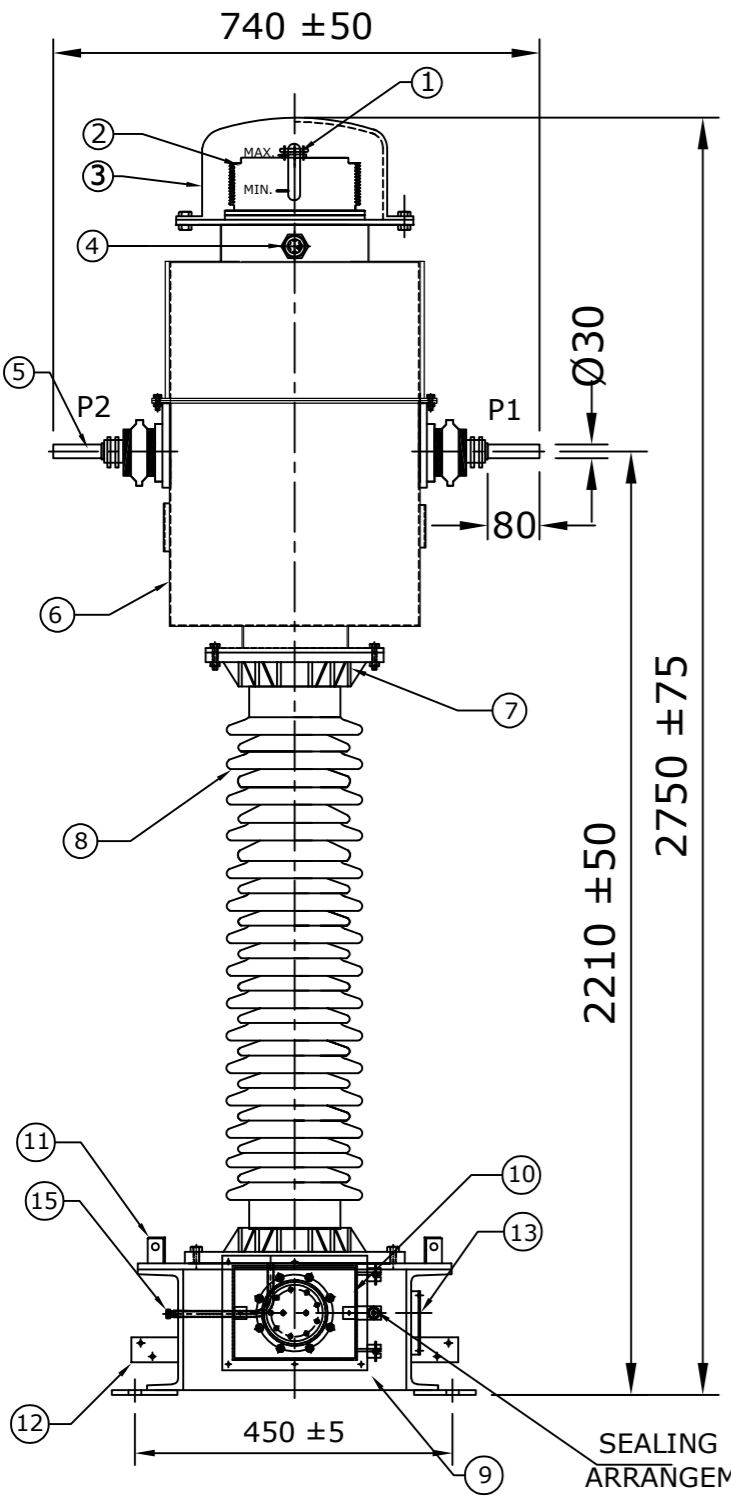
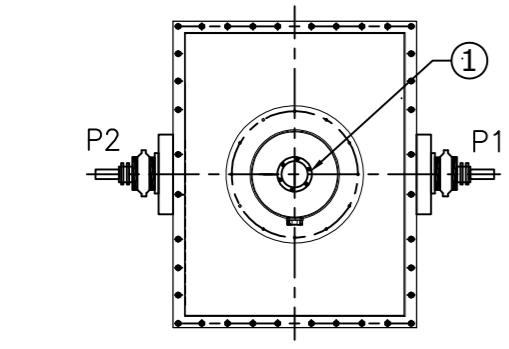

**CHIEF ENGINEER  
POWER SYSTEMS, PLANNING & DESIGN  
APTRANSCO**

CLIENT : TRANSMISSION CORPORATION OF ANDHRA PRADESH LIMITED  
PROJECT NAME : AS APPLICABLE

UNLESS OTHERWISE SPECIFIED	DATE	NAME	MATERIAL
1. ALL DIMENSIONS ARE IN mm.	DGN. 23.06.2021	SPS	AS ABOVE
2. TOLERANCE WHEREVER NOT INDICATED ±5%	DRN. 23.06.2021	AKASH	
	CHD. 23.06.2021	BLS	
	SCALE: N.T.S		

**MEHRU**  
MEHRU ELECTRICAL & MECHANICAL ENGINEERS (P) LTD.

TITLE :  
GENERAL ARRANGEMENT DRAWING FOR 132KV CURRENT TRANSFORMER RATIO:- 150/1A WOUND TYPE CT

SHEET No. 1 OF 7

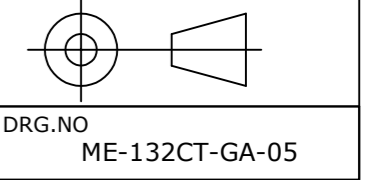

REV.	REVISION DESCRIPTION	DATED INITIALS
R0	FOR APPROVAL	23.06.2021

Drawing approval subject to valid vendor registration

**NOTES:-**

1. MAKE OF BUSHING: IEC/MODERN/ABIL/BHEL/CJI
2. ALL FERROUS PART EXPOSED TO THE ATMOSPHERE SHALL BE PAINTED WITH P.U PAINT SHADE 631 OF IS:5
3. ALL GASKETS SHALL BE FIXED IN PROPERLY MACHINED GROOVES.
4. PRIMARY WINDING SHALL BE WOUND TYPE.
5. ALL HARDWARE SHALL BE HOT DIP GALVANIZED.
6. TRANSFORMER OIL AS PER IEC : 60296.
7. ALL GASKETS SHALL BE MADE OF NITRILE BUTYL RUBBER.
8. THE CORES & SECONDARY WINDINGS SHALL BE ENCLOSED IN RIGID ALUMINUM SHELL.

- \* TOTAL WEIGHT OF CT:- 260Kgs (APPROX.)
- \* QUANTITY OF OIL:- 65 Ltrs (APPROX.)
- \* TOTAL CREEPAGE DISTANCE:- 3625 mm. (MINIMUM)

S.No.	DESCRIPTION	MATERIAL	QTY
1	OIL FILLING PORT	M.S	1
2	BELLOW	S.S	1
3	BELLOW DOME	M.S/AL.	1
4	OIL LEVEL INDICATOR	BRASS/AL.	1
5	PRIMARY TERMINAL Ø30x80mm	COPPER NICKEL PLATED	2
6	OIL TANK WITH COVER	M.S	1
7	SECONDARY TERMINAL	BRASS	---
8	BUSHING	PORCELAIN	1
9	BASE	M.S	1
10	SECONDARY TERMINAL BOX	M.S	1
11	LIFTING HOOK	M.S	4
12	EARTHING FLAT 80x50x8 mm. Thick.	M.S	2
13	NAME AND RATING PLATE	AL. ANODIZED	1
14	MOUNTING HOLE, 16mm dia	M.S	4

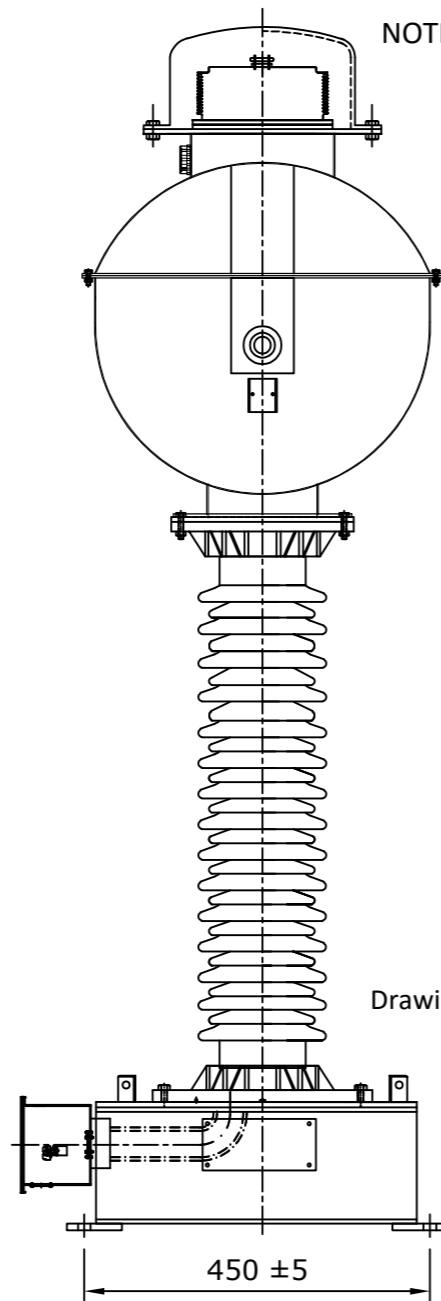
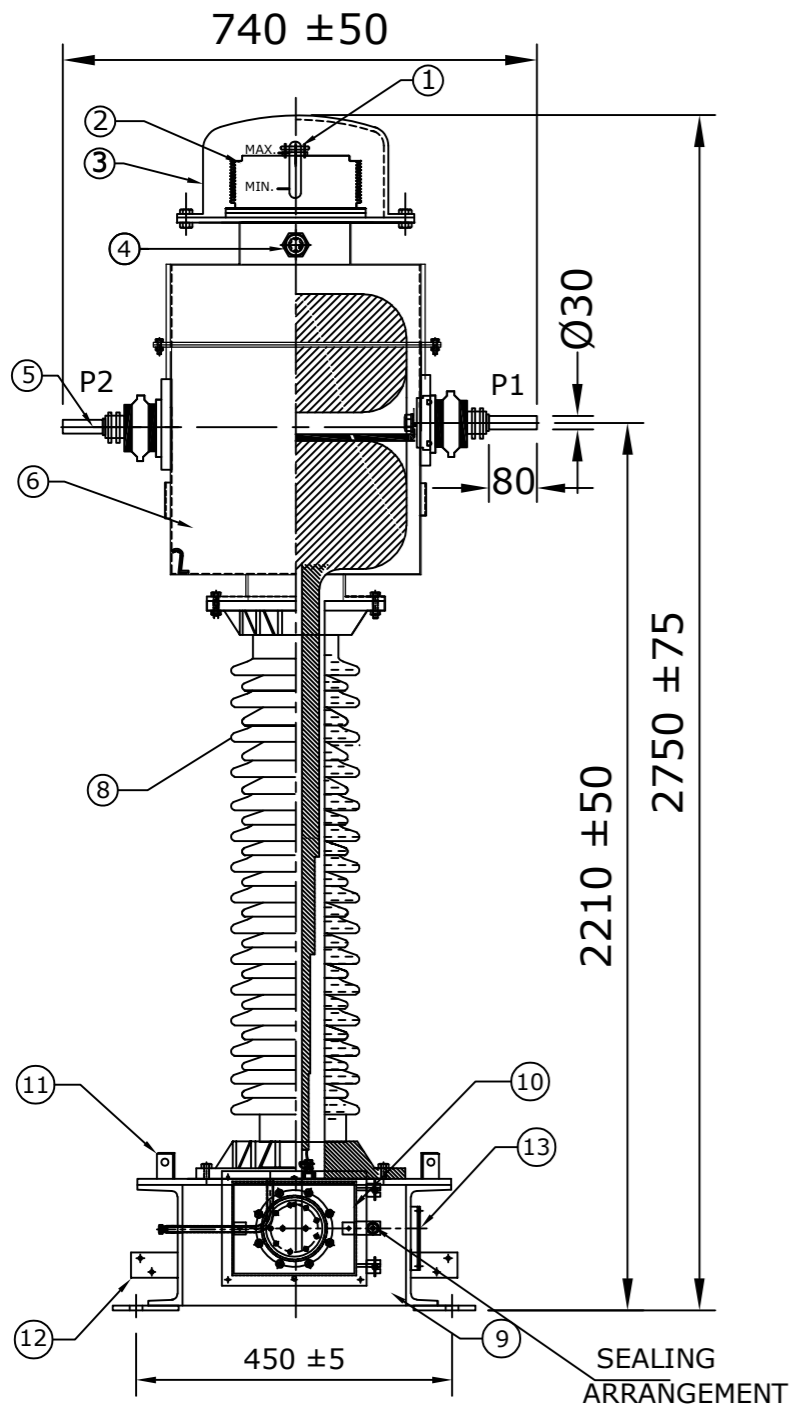
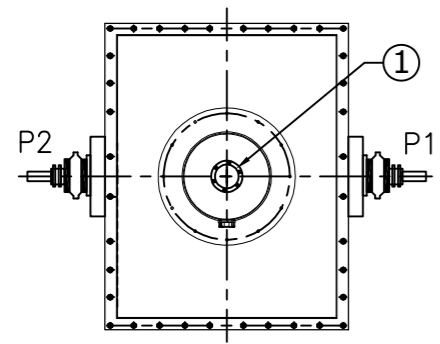

NOTE: 1. DRAWING APPROVAL SUBJECT TO VALID TYPE TEST REPORTS, TO BE CHECKED DURING ACCEPTANCE TESTS  
2. FOR EPC CONTRACTS ONLY

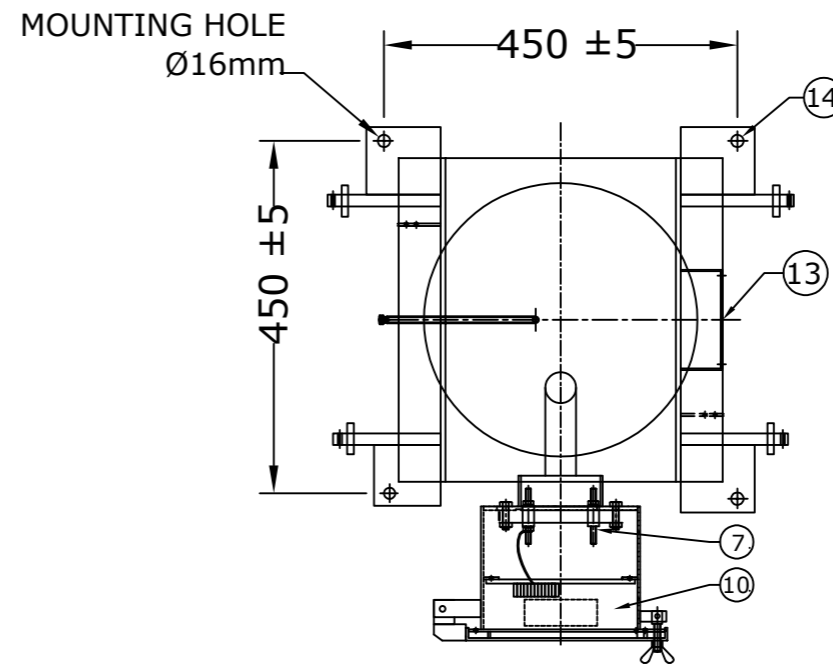

**MOUNTING DETAILS**

**CHIEF ENGINEER  
POWER SYSTEMS, PLANNING & DESIGN  
APTRANSCO**

Drawing approval subject to valid vendor registration

CLIENT : TRANSMISSION CORPORATION OF ANDHRA PRADESH LIMITED  
PROJECT NAME : AS APPLICABLE

UNLESS OTHERWISE SPECIFIED	DATE	NAME	MATERIAL
1. ALL DIMENSIONS ARE IN mm.	DGN. 23.06.2021	SPS	AS ABOVE
2. TOLERANCE WHEREVER NOT INDICATED ±5%	DRN. 23.06.2021	AKASH	
	CHD. 23.06.2021	BLS	
SCALE:	N.T.S		

**MEHRU**  
MEHRU ELECTRICAL & MECHANICAL ENGINEERS (P) LTD.

TITLE :  
SECTIONAL ARRANGEMENT DRAWING FOR 132kV CURRENT TRANSFORMER RATIO:- 150/1A WOUND TYPE CT

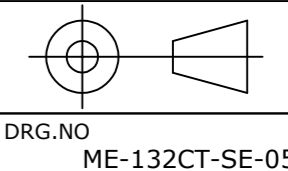

REV.	REVISION DESCRIPTION	DATED INITIALS
R0	FOR APPROVAL	23.06.2021

SHEET No. 2 OF 7

DRG.NO ME-132CT-SE-05

NOTE: 1. DRAWING APPROVAL SUBJECT TO VALID TYPE TEST REPORTS, TO BE CHECKED DURING ACCEPTANCE TESTS  
2. FOR EPC CONTRACTS ONLY

**MEHRU** LIVE TANK CURRENT TRANSFORMER  
MADE TO IS: 16227

HIGHEST SYSTEM VOLTAGE	145 kV	INSULATION LEVEL	275/650 kV
RATED S.T.C	31.5kA for 1 second	RATED FREQUENCY	50Hz
NOMINAL SYSTEM VOLTAGE	132 kV	CORE 1	
RATIO	PRIMARY(Amp)	150	
	SECONDARY(Amp)	1	
SECONDARY TERMINALS	1S1-1S2		
RATED BURDEN IN V.A	5 VA		
ACCURACY CLASS	0.2S		
ALF / ISF	≤5		
Min Knee point voltage	----		
Max Rct @ 75° C	----		
Max Iext @ Vk	----		
YEAR OF MANUFACTURE	2021	SERIAL NO.	

RATED CONTINUOUS THERMAL CURRENT: 120% OF THE RATED PRIMARY CURRENT  
 \* QUANTITY OF OIL:- 65 Ltrs (APPROX.) \* TOTAL WEIGHT OF CT:- 260Kgs (APPROX.)  
 MADE IN INDIA BY \* TOTAL CREEPAGE DISTANCE:- 3625 mm. (MINIMUM)  
**MEHRU ELECTRICAL AND MECHANICAL ENGINEERS (P) LTD.**  
 SP2/180,RIICO INDUSTRIAL AREA,KEHRANI, BHIWADI - RAJASTHAN - 301019

SUITABLE FOR HOT LINE WASHING

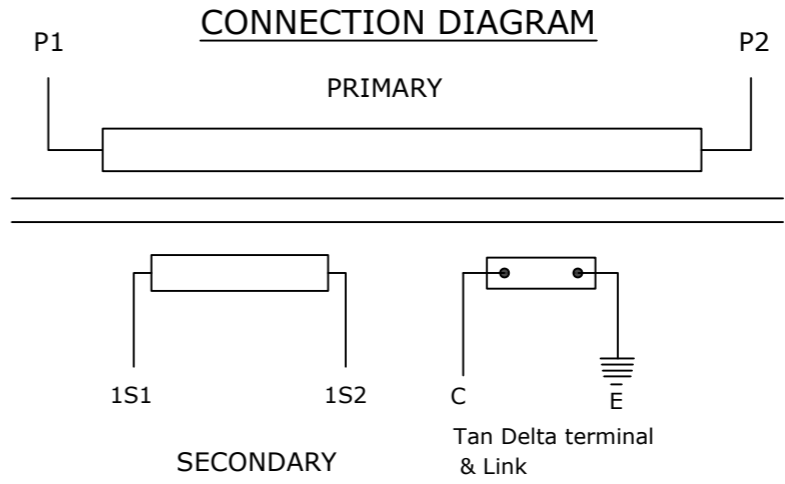

FOR RATIO	PRIMARY CONNECTION	SECONDARY CONNECTION
		CORE I
150/1A	P1-P2	1S1-1S2

**CAUTION**  
 I. Secondary terminals should be short circuited before the burden is disconnected.  
 II. Tan delta terminal 'C' must be shorted to be earth when operation  
 III. Do not remove earth link when in operation

105 ±15

225 ±20

**NOTES:-**

1. THICKNESS OF RATING PLATE 1.2 mm
2. MATERIAL OF NAME PLATE SHALL BE AL. ANODIZED.
3. SERIAL NUMBER SHALL BE ENGRAVING BEFORE THE DISPATCH.

- \* PRIMARY WINDING AREA : 200 sq.mm
- \* CURRENT DENSITY : 0.9 A/sq.mm
- \* MATERIAL OF PRIMARY CONDUCTOR: COPPER.
- \* No. OF PRIMARY TURN: 3
- \* No. OF SECONDARY TURN:450

**CHIEF ENGINEER**  
**POWER SYSTEMS, PLANNING & DESIGN**  
**APTRANSCO**

CLIENT : TRANSMISSION CORPORATION OF ANDHRA PRADESH LIMITED PROJECT NAME : AS APPLICABLE			
UNLESS OTHERWISE SPECIFIED	DATE	NAME	MATERIAL
1. ALL DIMENSIONS ARE IN mm. 2. TOLERANCE WHEREVER NOT INDICATED ±5%	DGN.	23.06.2021	SPS
	DRN.	23.06.2021	AKASH
	CHD.	23.06.2021	BLS
	SCALE:	N.T.S	
TITLE :			AL.ANODIZED
NAME PLATE DRAWING FOR 132kV CURRENT TRANSFORMER RATIO:- 150/1A WOUND TYPE CT			
SHEET No. 3 OF 7			MEHRU ELECTRICAL & MECHANICAL ENGINEERS (P) LTD.
DRG.NO ME-132CT-NP-05			

Drawing approval subject to valid vendor registration

RO	FOR APPROVAL	23.06.2021
REV.	REVISION DESCRIPTION	DATED INITIALS

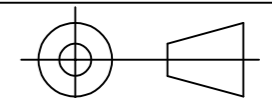

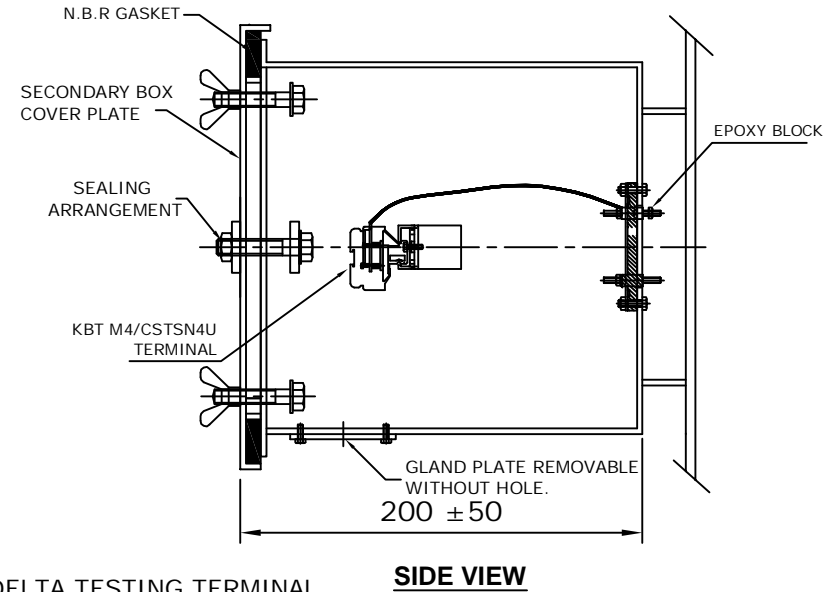
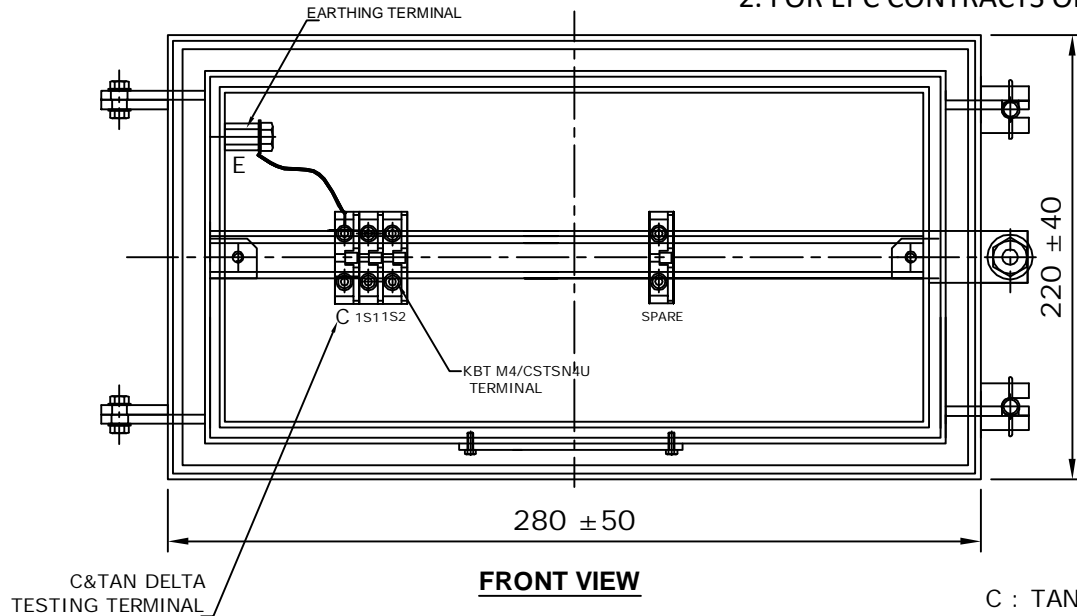

C : TAN DELTA TESTING TERMINAL  
E : EARTHING TERMINAL

**NOTES: -**

1. SECONDARY TERMINAL BOX SHALL BE PROVIDE GLAND PLATE REMOVABLE WITHOUT HOLE.
2. SECONDARY TERMINAL BOX SHALL BE PROVIDED WITH COVER.
3. M.S SHEET THICKNESS FOR TERMINAL BOX 3.0mm & FOR COVER 2.0mm.
4. MATERIAL OF GASKET : NITRILE BUTYL RUBBER GASKET.
5. DEGREE OF PROTECTION : IP 55
6. 20% SPARE TERMINAL SHALL BE PROVIDED.

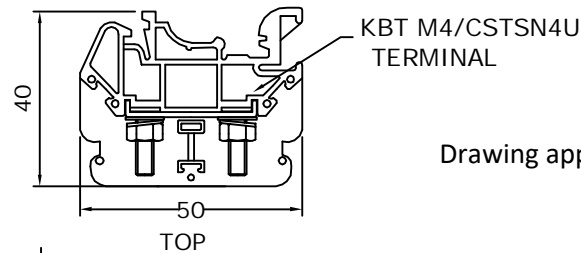

Drawing approval subject to valid vendor registration

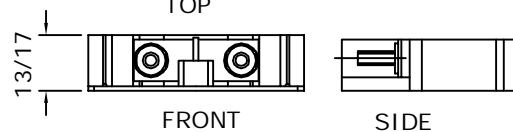

MATERIAL: POLYAMIDE  
MAKE: ELMEX/CONNECTWELL

**TERMINAL (DETAIL)**

RO	FOR APPROVAL	23.06.2021
REV.	REVISION DESCRIPTION	DATED INITIALS

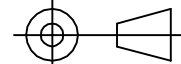
CLIENT : TRANSMISSION CORPORATION OF ANDHRA PRADESH LIMITED				
PROJECT NAME : AS APPLICABLE				
UNLESS OTHERWISE SPECIFIED	DATE	NAME	MATERIAL	<div style="border: 1px solid black; padding: 2px; display: inline-block;">MEHRU</div> MEHRU ELECTRICAL & MECHANICAL ENGINEERS (P) LTD.
1. ALL DIMENSIONS ARE IN mm.	DGN. 23.06.2021	SPS	M.S	
2. TOLERANCE WHEREVER NOT INDICATED ±5%	DRN. 23.06.2021	AKASH		
	CHD. 23.06.2021	BLS		
	SCALE: N.T.S			
TITLE : SECONDARY TERMINAL BOX DRAWING FOR 132KV CURRENT TRANSFORMER RATIO: - 150/1A WOUND TYPE CT				 DRG.NO ME-132CT-STB-05
SHEET No. 4 OF 7				

**CHIEF ENGINEER  
POWER SYSTEMS, PLANNING & DESIGN  
APTRANSCO**

<b>Guaranteed Technical Particulars for 132kV Current Transformer</b>			
Sl. No.	Item Description	Unit	GTP as per Bid
<b>E</b>	<b>CURRENT TRANSFORMER</b>		
1	Make		Mehru Electrical & Mechanical Engineers (P) Ltd, Bhiwadi, (Raj), Inida
2	Type and Designation		Outdoor, Oil Cooled Live Tank Type, Current Transformer
3	Applicable standards		IS 16227
4	Class		A
5	Rated Voltage	132 kV	132 kV
6	Rated Primary current	Amps	150A
7	Rated Secondary current	Amps	1
8	Rated output (Burden)	VA	Core:-1 5VA
9	Rated output at 0.8 lag. p.f.	VA	N/A
10	Class of accuracy		Core:1 - 0.2S
11	Accuracy limit factor		N/A
12	Knee point voltage @highest tap	Volts	N/A
13	CT Resistance of secondary winding corrected to 75 deg.C @highest tap	Ohms	N/A
14	Magnetising current at knee-voltage point @highest tap		N/A
15	secondary limiting voltage	kV	As per IS 16227
16	Instrument security factor for winding meant for metering		Core-1-≤ 5
17	One minute Power Frequency withstand test voltage of		
a)	Primary winding	kV (rms)	275
b)	Secondary winding	kV (rms)	3
18	Impulse wave withstand voltage of primary winding	kV (peak)	650
19	One minute dry P.F. withstand voltage of primary winding	kV (rms)	275

NOTE: 1. DRAWING APPROVAL SUBJECT TO VALID TYPE TEST

4714210/2021/EEMRT-ENE51 REPORTS, TO BE CHECKED DURING ACCEPTANCE TESTS

2. FOR EPC CONTRACTS ONLY

Drawing approval subject to valid vendor registration

20	Creepage distance	mm	25mm/kV i.e. 3625mm (Min.)
21	Rated continuous thermal current	Amps	120% of rated primary current
22	Ratios available at highest taps		Yes
23	Rated short time thermal current	kA (rms)	31.5 kA
24	Rated time for above	Sec.	1
25	Rated dynamic current for primary	kA (Peak)	78.75
26	Class of insulation		A
27	Max. Temperature rise over ambient of 50 deg.C at any part of oil	deg.C	50c max
28			
b)	Radio interference voltage		As per IS 16227 Clause 6.11.2 <2500uV
c)	Partial discharge level		<10 pC at Um & <5 pc at 1.2Um/√3
29	Temp. rise after passing short time thermal current for one second	deg.C	50c max
30	Current density in primary winding at		
a)	Normal rating		0.9 Amp/sqmm (max)
b)	Short time rating of 1 Sec.		157.5 Amp/sqmm(max.)
c)	Dynamic rating		393.75 Amp/sqmm (max.)
31	Type of primary winding		Copper
32	No. of primary turns		3
33	No. of secondary turns		450
34	Flux density at knee point		1.4 Tesla
35	Radio interference voltage	(micro volts)	
a)	with terminal connector mountd		<2500uV
b)	under test condition		<2500uV
36	Variation in ratio and phase angle error due to variation in		

NOTE: 1. DRAWING APPROVAL SUBJECT TO VALID TYPE TEST  
**4714210/2021/EEMRT-ENE51** REPORTS, TO BE CHECKED DURING ACCEPTANCE TESTS

2. FOR EPC CONTRACTS ONLY

a)	Voltage by 1%		N/A
b)	Frequency by 1 Hz.		N/A
37	Mounting details		450±5 x 450±5 mm
38	Source/grade of oil and standard with which it complies		EHV Grade Transformer Oil as per IS 335/IEC 60296 of any reputed make
39	Quantity of insulating oil	Litres	65 Ltr Approx
40	Weight of Oil	kg	52 kgs Approx
41	Total Weight including Oil	kg	260kG Approx
42	Overall dimensions (mm)		2750±75 x 740±50 x 450±5 mm
43	Wheather sealed (if so, type of sealing)		Yes, By SS BELOW

**CHIEF ENGINEER  
POWER SYSTEMS, PLANNING & DESIGN  
APTRANSCO**

Drawing approval subject to valid vendor registration