

2.For EPC contractors only.

Drawing approval subject to valid vendor registration

**CHIEF ENGINEER/PROJECTS
APTRANSCO/VISVIJAYAWADA**

**ANNEXURE-I
GUARANTEED TECHNICAL PARTICULARS FOR DG SETS (15 KVA)**
(To be filled in by the Bidder separately for each rating)

Sl. No.	Specification	Capacity of DG sets = 15 KVA, 3 ph, 415 V with manual control panel & Air Cooled type Engine
1	Standards:	
	Engine Make (Mahindra & Mahindra/Kirloskar/Eicher)	Eicher-TMTL
	Alternator Make (Crompton Greaves /Stamford/ Kirloskar)	Crompton Greaves (CG) / STAMFORD
2	Specification of Engine	BS 5514/IS 10001/IS 10002/DIN 6271
2.1	Make (Mahindra & Mahindra/Kirloskar/Eicher)	Eicher
2.2	Model	322ES
2.3	No. of Cylinders	2
2.4	No. of Strokes	4
2.5	RPM	1500 (Rated)
2.6	BHP at NTP conditions	24.8
2.7	Cooling (Air cooled type/Liquid cooled type)	Air Cooled Type
2.8	Operating Condition C	NTP
2.9	Type of Injection	Direct Inline Injection
2.10	Recommended Fuel Oil	Diesel
2.11	Fuel Oil consumption at full load:	3.8 L/Hr
2.12	Recommended Lubricating Oil:	RAKSHAK OIL SAE 15W40 API CF4 GRADE
2.13	Lubricating Oil consumption at full load	LESSTHAN 0.15% OF SFC
2.14	Lube Oil Sump capacity	8 Ltrs(Incl. Filters)
2.15	Lubricating System Type and details	Forced Lubrication
3	Governing System Type and details	Mechanical/A1 Class
4	Method Starting	Electric Start
5	Battery Type & make, capacity etc.	Lead Acid, 150Ah



Engine stop push Button BP shall be Provided

7591765/2023/EEMRT-ENF51

- NOTE: 1. Drawings Approval subject to valid type test reports, to be checked during acceptance tests.
2. For EPC contractors only.

6	Acoustic Enclosure details Noise level	<75 dB
7	Cooling System consist of	Air Cooled with Fan
8	Fuel Tank capacity & size	75 Liters
9	Fuel System	High Pressure Direct Injection into Piston cavity
10	Lubricating system	Forced Lubrication
11	Air in take system	Natural Aspirated
12	Exhaust System	Single Manifold Type
13	Safety Control	9900c
14	Other Accessories	Standard as per our offer
15	Mounting-	Anti Vibration Mounts (AVMs)
16	3 Sets of following documents shall be provided with each DG set	Engine, Alternator, DG test certificates
17	Alternator	
17.2	Make (Crompton Greaves /Stamford/ Kirloskar)	Crompton Greaves/ Stamford
17.2	Rating	15
17.3	Frame	According to the Make
17.4	Power Factor	0.8
17.5	Rated Voltage	415 L-L \pm 10%
17.6	Frequency	50 \pm 2%
17.7	Class of Insulation	H-Class
17.8	Degree of Protection	IP 23
17.9	Bearing	Single(SAE11)
17.1	Excitation	Self
17.11	Space Heater	NA
17.12	AVR Type	Electronic/Governing
18	Type of Control Panel (Manual Control Panel)	Manual Control Panel
19	Cooling (Air cooled /liquid cooled type)	Air Cooled Type
20	COUPLING & MOUNTING ARRANGEMENT:	Closed Coupling
21	Type of Enclosure	Acoustic with PU Foam
21.1	Emission norms	CPCB II
21.2	Emission limits	According to CPCB II
22	Smoke limit	According to CPCB II
23	Load Test Cycle	3 Hours
24	Documents/certificates to be submitted at the time of supply.	Yes
24.1	Scope of Inspection	Yes
24.2	Physical inspection	Yes
25	Over Load Test Cycle	Yes (10% Over Load for every 11 Hrs Cont. Operation)

Engine stop push Button BP shall be Provided



NOTE: 1. Drawings Approval subject to valid type test reports, to be checked during
7591765/2023/EEMRT-ENE51 acceptance tests.

2. For EPC contractors only.

Engine stop push Button BP shall be Provided

The following notice to be pasted on the Engine in a sticker form

“RAKSHAK OIL SAE 15W40 APICF4 GRADE to be used as lubricating oil lub oil sump capacity 8 ltrs”.

26	Fuel Consumption test	Yes
27	Earthing system	Provisioned
28	Power Cable	6 Sq.mm Copper
29	Overall length of DG set LxWxH mm	1700x900x1250
30	Overall weight of DG set	Appr. 850 Kgs
31	Noise level at one meter with Acoustic enclosure	< 75 db
32	Control panel make	Pinnacle Generators

NOTE: Preventive Maintenance need to be done for every 250Hrs of DG Run Time (except 1st service has to be done at 50Hrs)

Remarks: An In-built battery charger mounted inside the Control Panel for charging the batteries from an external AC supply may be provided for float/ boost charging in addition to the standard DG set-driven charger.

Name of the firm PINNACLE GENERATORS

Signature of Bidder.....

Name & Designation & Seal

Date :



Drawing approval subject to valid vendor registration

**CHIEF ENGINEER/PROJECTS
APTRANSCO/VS/VIJAYAWADA**

Note : Slant Roof of 10 mm is provided on One side for flow of rain water. (Ref. as below drawing.)

NOTE: 1. Drawings Approval subject to valid type test reports, to be checked during acceptance tests.
2. For EPC contractors only.

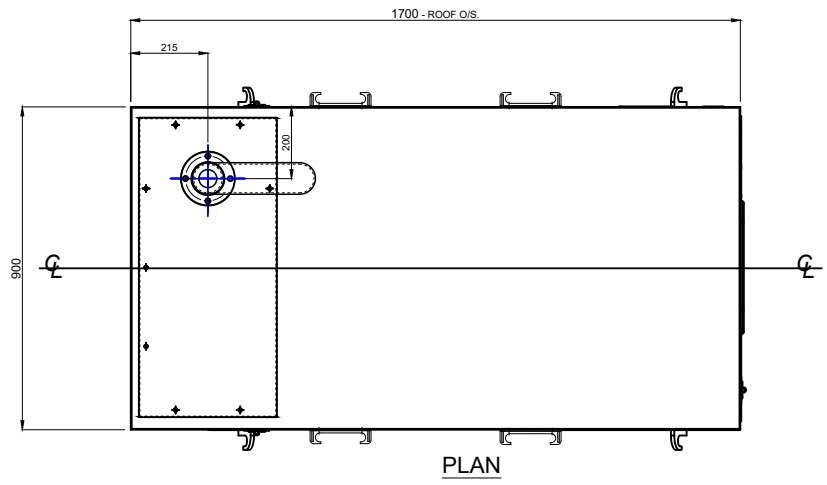

GENERAL ARRANGEMENT OF 15 KVA SILENT DG SET POWERED BY EICHER 322ES AIR COOLED ENGINE (FOR STATIONARY APPLICATION)

Engine stop push Button BP shall be Provided

CHIEF ENGINEER/PROJECTS
APTRANSCO/VISVIJAYAWADA

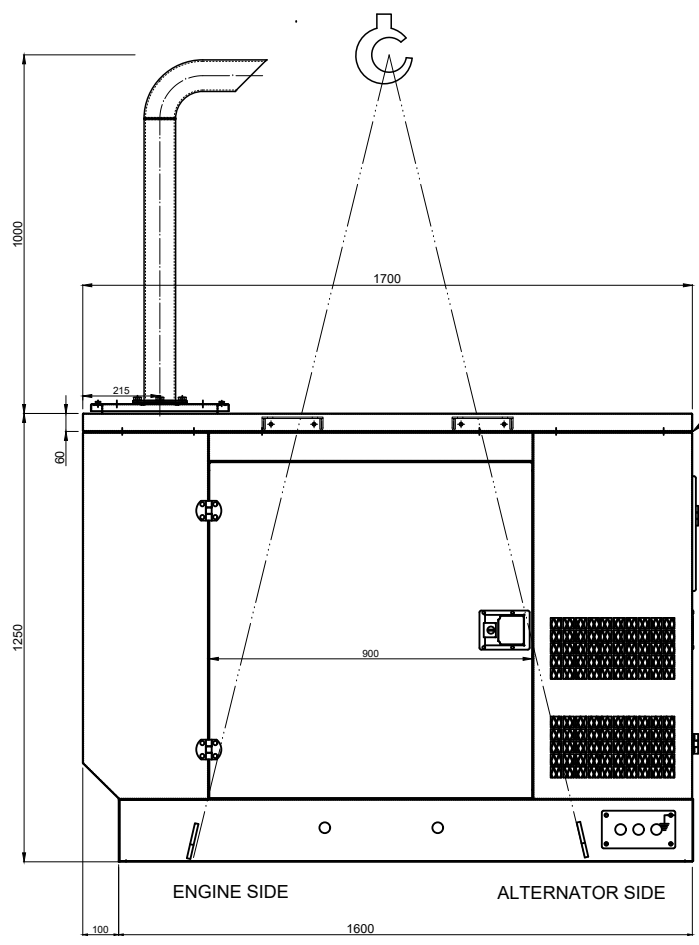
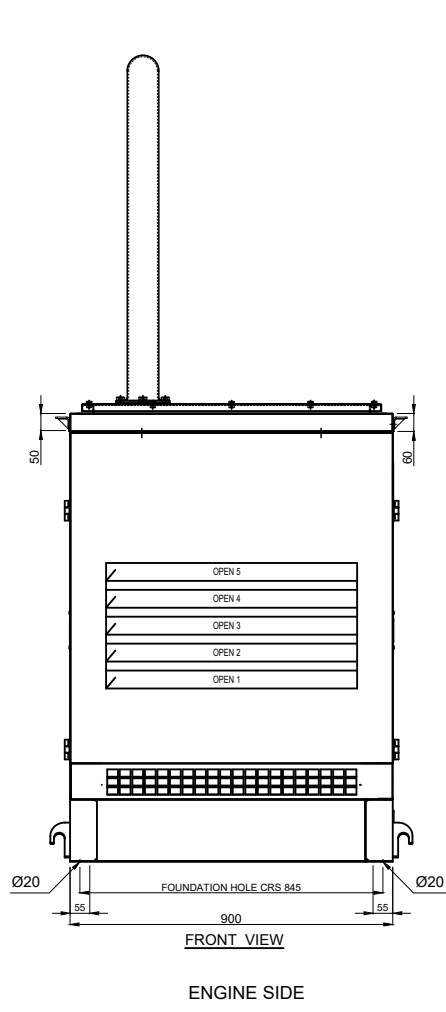
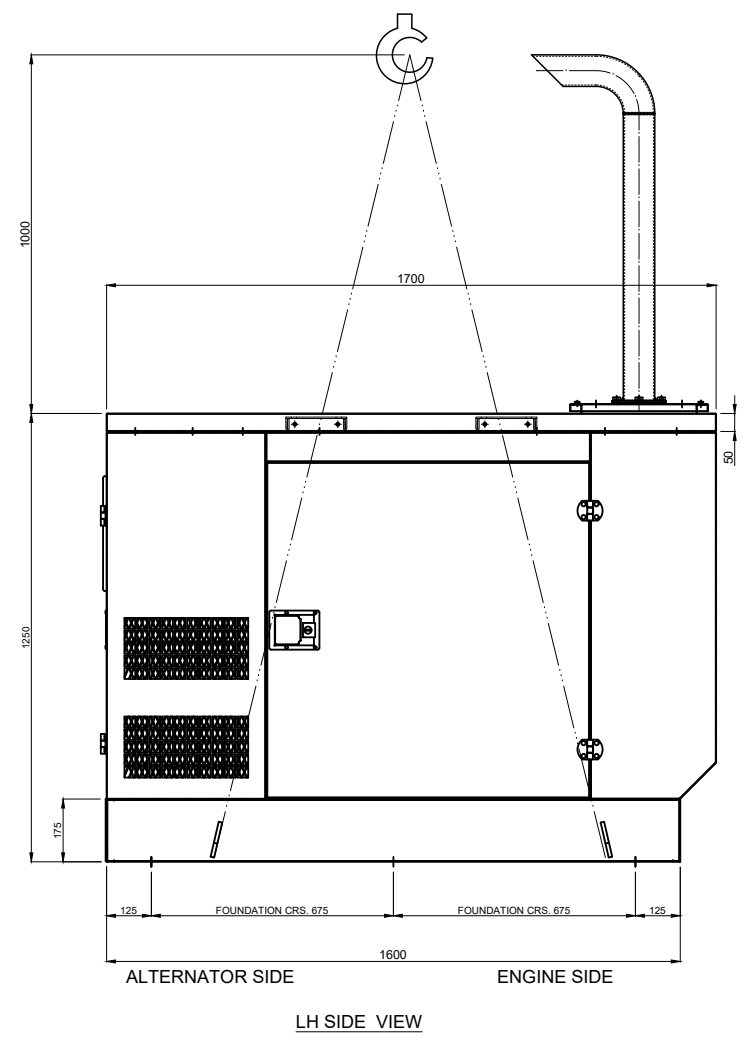

40x3 SELF ADHESIVE SPONGE TAPE OR TEE BEADING WITH SILICON SEALANT BETWEEN ROOF & BODY PANELS - ALL AROUND

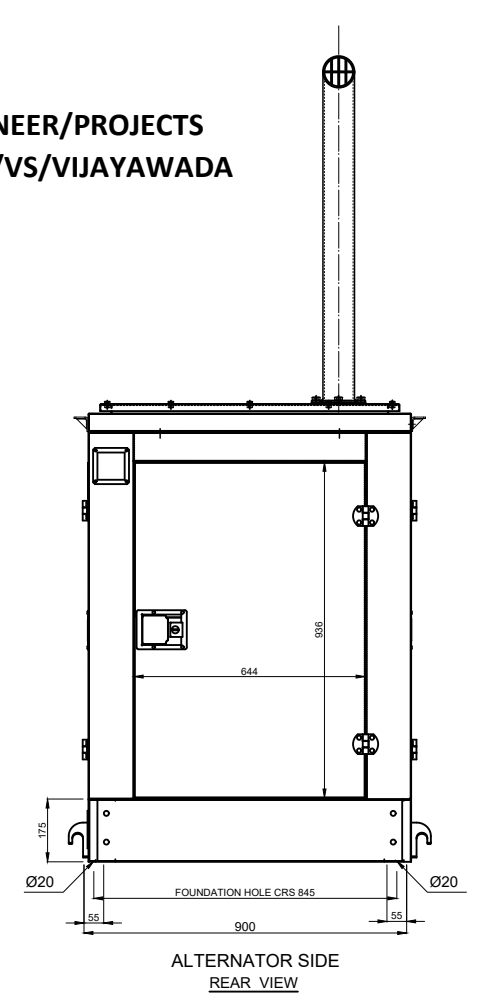

NOTE:
1. MODULAR CONSTRUCTION.
2. ALL DIMENSIONS ARE IN mm U.O.S.
3. DO NOT SCALE. ASK IF ANY DOUBT.
4. ALL BOLTED JOINTS TO BE SEALED USING SILICON SEALANT.
5. OVERALL DIMENSIONAL TOLERANCE ±5.0 mm.
6. FOR LIFTING THE GENSET, USE NYLON STRAP OF SUITABLE CAPACITY ALONG WITH THE SPREADERS.

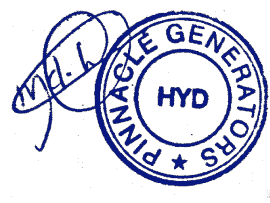

Drawing approval subject to valid vendor registration

IMPORTANT NOTES:
1. SOUND INSERTION LOSS SHOULD BE MIN. 25 dBA AT EXHAUST OUT-LET AT 1 mt. AT 100% LOAD.
2. EXHAUST BACK PRESSURE SHOULD NOT EXCEED 60% OF THE VALUE SPECIFIED AS PER TECHNICAL SPECS. OF THE ENGINE.
3. SILENCER AND STACK PIPE TO BE PAINTED USING HIGH TEMPERATURE (HEAT RESISTANT) PAINT.
4. SILENCER TO BE THERMALLY INSULATED FROM INSIDE USING 25 MM THK CERAMIC WOOL BLANKET OF MIN. 64 Kg/m³ DENSITY / AS PER NOTE IN DRG.
5. SOLID PORTION EXHAUST EXTENSION TILL SILENCER TO BE LAGGED USING RESIN BONDED Ø8 ASBESTOS ROPE.
6. ENSURE THERMAL INSULATION OF EXHAUST MANIFOLD WITH THERMAL JACKET OR Ø8 RESIN BONDED ASBESTOS ROPE.
7. Ø14 TUBULAR DOOR BEADING TO BE FIXED ON DOOR STAY MEMBERS.
8. ALL JOINTS OF THE BODY PANEL TO BODY PANEL AND BODY PANEL TO BASE FRAME TO BE SEALED USING SILICON SEALANT TO AVOID WATER INGRESS.
9. APPLY 20X3 SINGLE SIDE SELF-ADHESIVE TAPE BETWEEN DETACHABLE HATCH LIDS ON ROOF / FRONT & BACK PANEL AND ITS STAY (AS APPLICABLE).

R.NO.	DR NO.	DESCRIPTION (LOCATION)	DATE	CHANGED BY	APPD. BY
A UNIT OF TMTL		CRITICAL CHARACTERISTIC	PART NO.	DR. NO.	
		SIGNIFICANT CHARACTERISTIC	PART NAME	G. A. OF 15 KVA SILENT DG SET WITH 322 ES EICHER ENGINES - 3 DOOR CONFIGURATION	
UNSPECIFIED TOLERANCES AS PER ISO-2768-1:1989			MATERIAL	AS SHOWN IN INDIVIDUAL COMPONENT DRG.	
DIMENSIONS		DRAWING NO AL 1235			
LINEAR IN mm		REV a QTY. 1			
OVER 0.5		SCALE NTS			
LPTO 3		Wt. (Kg)			
FINE (X.XXX) 00.05		S.A. (mm ²)			
M. MEDIUM (X.XX) 0.1		HEAT TREATMENT / SURF. TREATMENT			
C. COARSE (X.X) 0.2		DRAWN RKM 12.04.18			
VERY COARSE (X) 0.5		CHKD SA 12.04.18			
ANGULAR IN deg		APPD SA 12.04.18			
OVER 15		1			
LPTO 10		A 2			
FINE (X.XXX) 0.1°		1			
M. MEDIUM (X.XX) 0.5°					
C. COARSE (X.X) 1°					
VERY COARSE (X) 2°					

This drawing is the sole property of EICHER ENGINES. It shouldn't be copied / communicated to any person without written approval of proprietors.

ALL DIMENSIONS ARE IN mm UNLESS SPECIFIED

**GENERAL ARRANGEMENT OF 15 KVA
SILENT DG SET POWERED BY EICHER
322ES AIR COOLED ENGINE
(FOR STATIONARY APPLICATION)**

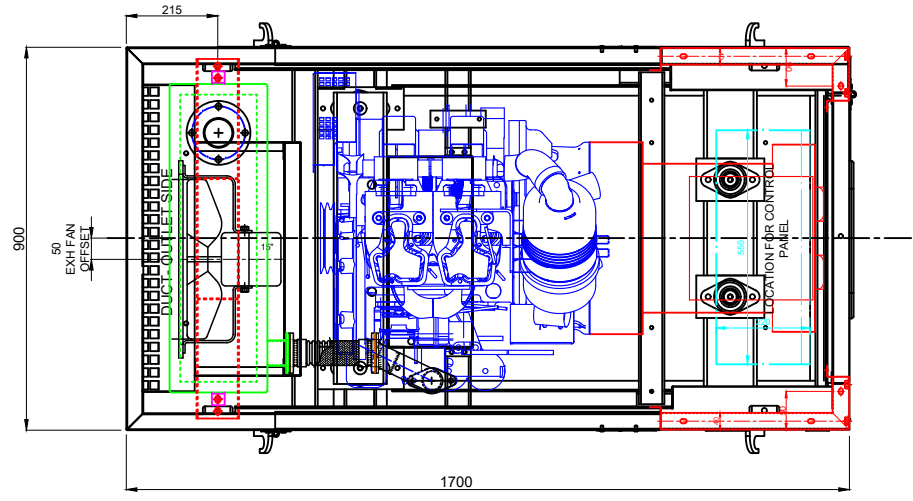

Engine stop push Button BP shall be Provided

The following notice to be pasted on the Engine in a sticker form
"RAKSHAK OIL SAE 15W40 APICF4 GRADE to be used as lubricating oil lub oil sump capacity
8 ltrs".

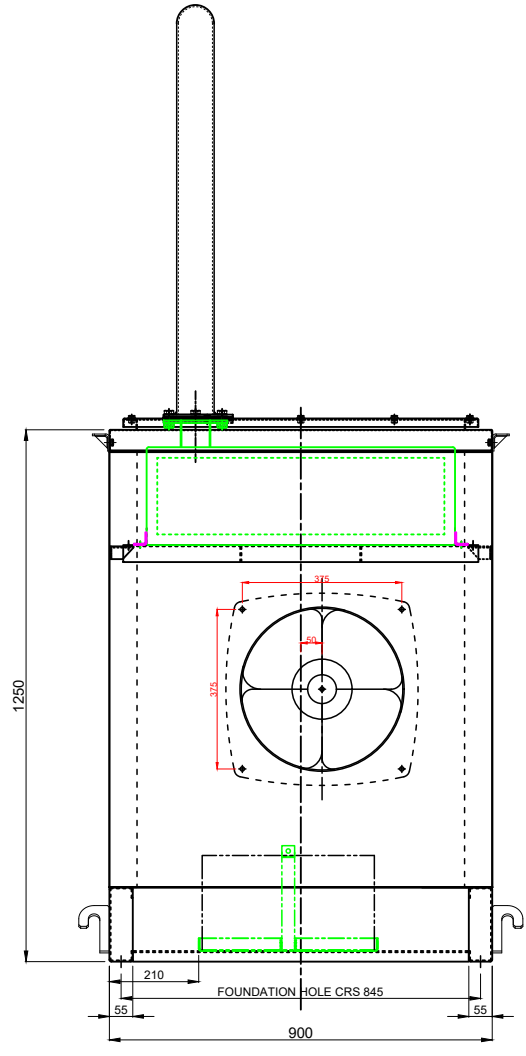

FRONT VIEW
STACK PIPE OMITTED IN THIS VIEW FOR CLARITY

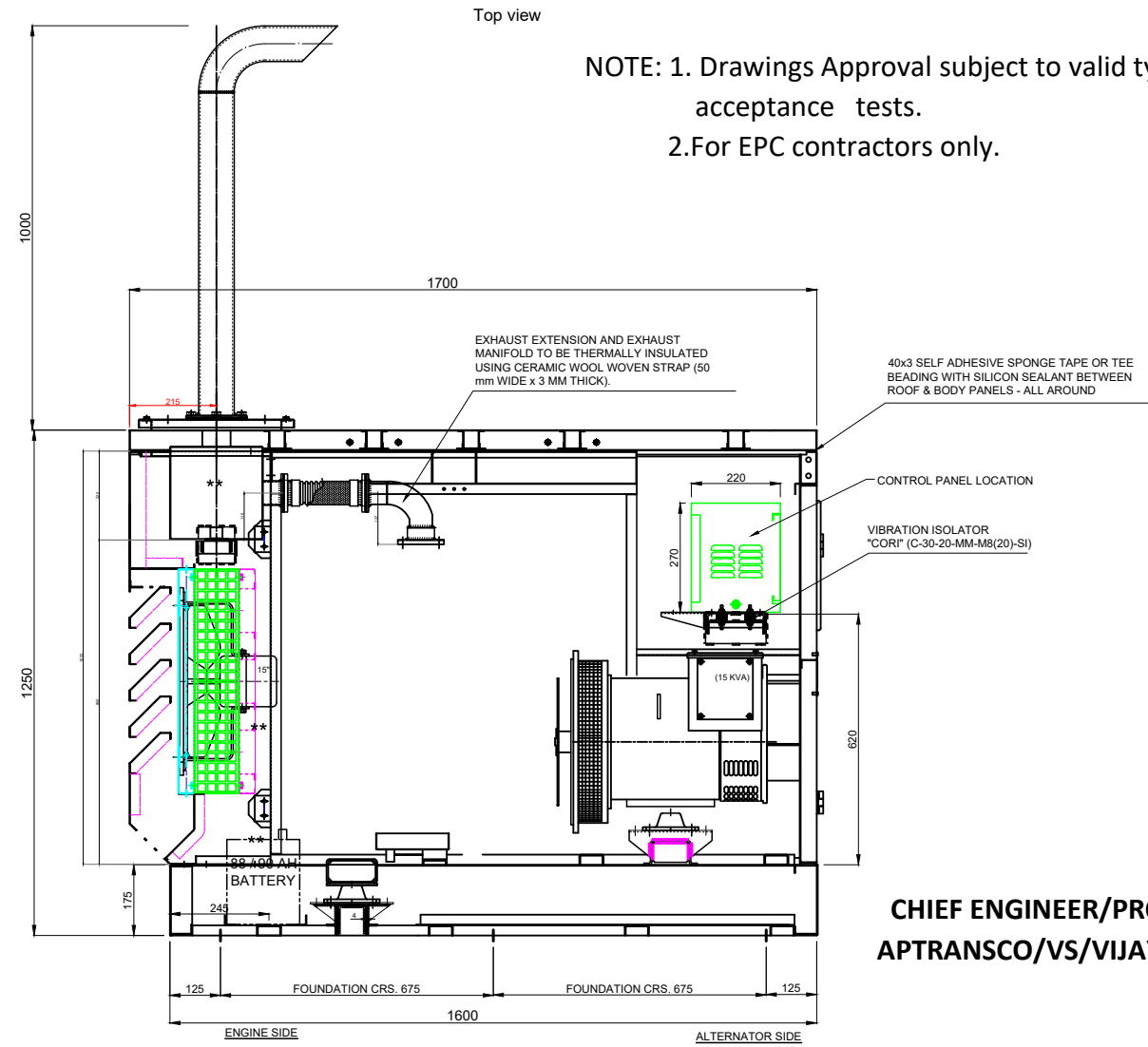

Top view

SIDE VIEW

NOTE: 1. Drawings Approval subject to valid type test reports, to be checked during acceptance tests.
2. For EPC contractors only.

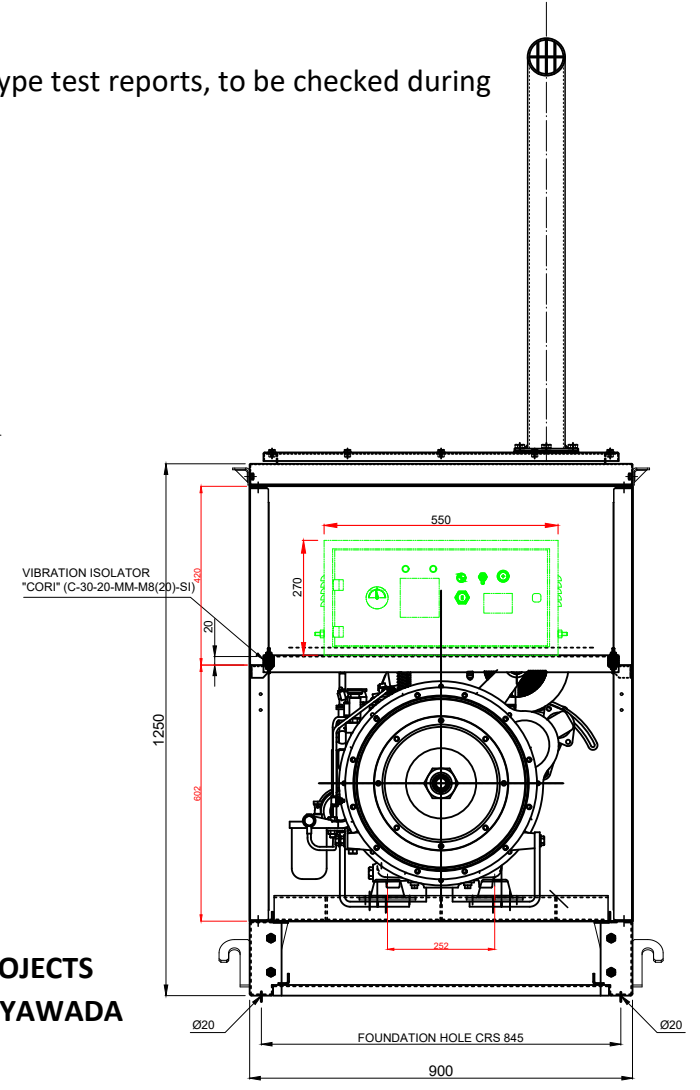

REAR VIEW

**CHIEF ENGINEER/PROJECTS
APTRANSCO/VISVIJAYAWADA**

- IMPORTANT NOTES:**
- SOUND INSERTION LOSS SHOULD BE MIN. 25 dBA AT EXHAUST OUT-LET AT 1 ml. AT 100% LOAD.
 - EXHAUST BACK PRESSURE SHOULD NOT EXCEED 60% OF THE VALUE SPECIFIED AS PER TECHNICAL SPECS. OF THE ENGINE.
 - SILENCER AND STACK PIPE TO BE PAINTED USING HIGH TEMPERATURE (HEAT RESISTANT) PAINT.
 - SILENCER TO BE THERMALLY INSULATED FROM INSIDE USING 25 MM THK CERAMIC WOOL BLANKET OF MIN. 64 Kg/m³ DENSITY / AS PER NOTE IN DRG.
 - SOLID PORTION EXHAUST EXTENSION TILL SILENCER TO BE LAGGED USING RESIN BONDED Ø8 ASBESTOS ROPE.
 - ENSURE THERMAL INSULATION OF EXHAUST MANIFOLD WITH THERMAL JACKET OR Ø8 RESIN BONDED ASBESTOS ROPE.
 - Ø14 TUBULAR DOOR BEADING TO BE FIXED ON DOOR STAY MEMBERS.
 - ALL JOINTS OF THE BODY PANEL TO BODY PANEL AND BODY PANEL TO BASE FRAME TO BE SEALED USING SILICON SEALANT TO AVOID WATER INGRESS.
 - APPLY 20X3 SINGLE SIDE SELF-ADHESIVE TAPE BETWEEN DETACHABLE HATCH LIDS ON ROOF / FRONT & BACK PANEL AND ITS STAY (AS APPLICABLE).

NOTE:
1. MODULAR CONSTRUCTION, FOR OUT-DOOR APPLICATION.
2. OVERALL DIMENSIONAL TOLERANCE ± 5 mm.
3. ALL DIMENSIONS ARE IN mm. U.O.S.
4. DO NOT SCALE. ASK IF IN DOUBT.

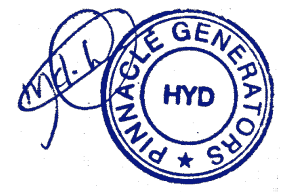

a		CONTROL PANEL SIZE & POSN. MODIFIED		21.10.18	SA	SA
R.NO	DR NO.	DESCRIPTION (LOCATION)		DATE	CHANGED BY	APPD. BY
A UNIT OF		CRITICAL CHARACTERISTIC	PART NO.	INTERNAL ARRANGEMENT OF 15 KVA DG SET WITH INTERNAL SILENCER		
UNSPECIFIED TOLERANCES AS PER ISO-2768-1:1989		SIGNIFICANT CHARACTERISTIC	PART NAME	AS SHOWN IN INDIVIDUAL COMPONENT DRG.		
DIMENSIONS		DRAWING NO		REV	a	QTY.
LINEAR IN mm		AL 1236				1
COVER		HEAT TREATMENT / SURF TREATMENT		SCALE NTS		
T FINE		DRAWN RKM		16.04.18		
M MEDIUM		CHKD SA		16.04.18		
C COARSE		APPD SA		16.04.18		
V VERY COARSE		A 2		1		
ANGULAR IN deg		16.04.18		1		
COVER		16.04.18		1		
T FINE		16.04.18		1		
M MEDIUM		16.04.18		1		
C COARSE		16.04.18		1		
V VERY COARSE		16.04.18		1		

NOTE: 1. Drawings Approval subject to valid type test reports, to be checked during acceptance tests.
 2. For EPC contractors only.

TYPE OF PANEL	MANUAL CONTROL PANEL
DG RATING	15KVA,AIR COOL,WITH 3DOOR AE
AC VOLTAGE SYSTEM	3PH, 415VAC,50 HZ
CONTRL VOLTAGE	12VDC
GENSET CONTROLLER USED	TEC9900C

Engine stop push Button BP shall be Provided

The following notice to be pasted on the Engine in a sticker form
 "RAKSHAK OIL SAE 15W40 APICF4 GRADE to be used as lubricating oil lub oil sump capacity 8 ltrs".

TABLE OF CONTENTS	
PAGE	TITLE
1 OF 7	INDEX
2 OF 7	GA DRAWING AND LEGEND
3 OF 7	AC CIRCUIT
4 OF 7	CONTROL CIRCUIT
5 OF 7	CONTROL CIRCUIT AND TB
6 OF 7	RS485 AND TELECOM SHEET IF REQUIRED
7 OF 7	BILL OF MATERIAL

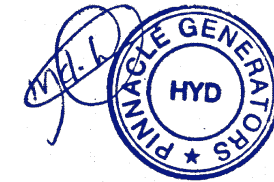

CHIEF ENGINEER/PROJECTS
APTRANSCO/VISVIJAYAWADA

Drawing approval subject to valid vendor registration

---	---	---	---	BKM	SA
---	---	NEW RELEASE	11/09/19	BKM	SA
R.ND	DR. NO.	DESCRIPTION (LOCATION)	DATE	CHANGED BY	APPD. BY
		TMTL			
		CRITICAL CHARACTERISTIC	PART NO.		
		SIGNIFICANT CHARACTERISTIC	PART NAME	15KVA,3PHASE,MCP	
SHEET DESCRIPTION:		MATERIAL			
COVER SHEET		DRAWING NO.	AL 1715	REV.	QTY. 1
					SCALE NTS
					Wt. (KG)
					S.A. (MM ²)
		DRAWN	BKM	DATE: 11/09/19	
		CHKD	SA	DATE: 11/09/19	
		APPD	SA	DATE: 11/09/19	A 3 1 7

This drawing is the sole property of Eicher Engines. It should not be copied, communicated to any person without written approval of proprietors.

ALL DIMENSIONS ARE IN MM UNLESS SPECIFIED

NOTE: 1. Drawings Approval subject to valid type test reports, to be checked during acceptance tests.
 2. For EPC contractors only.

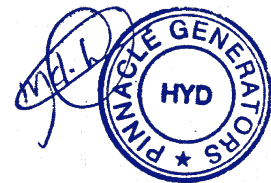
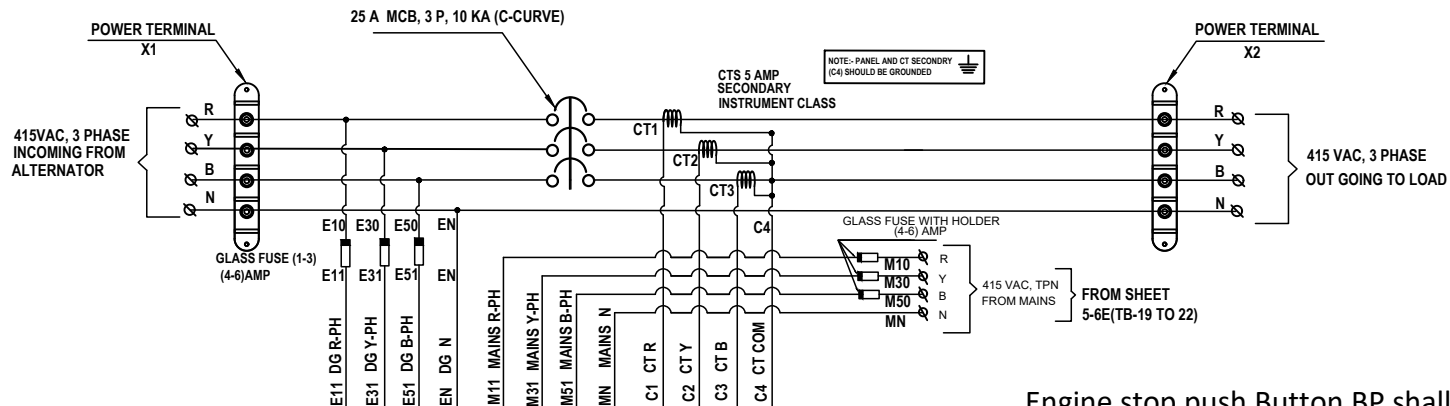

Engine stop push Button BP shall be Provided

25	26	27	28	29	30	31	32	33	34	35	36	37	38
R-Ph (DG)	Y-Ph (DG)	B-Ph (DG)	N (DG)	R-Ph (Mains)	Y-Ph (Mains)	B-Ph (Mains)	N (Mains)	R-CT	Y-CT	B-CT	CT COM	FAN CT in	FAN CT out

USB PORT FOR PROGRAMMING

EMERGENCY STOP TO SHEET 5-6B (T.B. - 08) K16

- K53 FUEL SENSOR } TO SHEET 5-6B(TB 11)
- K32 HCT. SENSOR } TO SHEET 5-6D(TB 14)
- K43 LLOP SENSOR } TO SHEET 5-6B(TB 10)

NOTE: INPUT SUPPLY AT TERMINAL 29, 30, 31 & 32 TO BE GIVEN FOR AUTO STOP WITH MAINS SENSING.

* MCB RATING FOR POWER :-
 1. FOR 15KVA :- 25A MCB-3P (C- CURVE & 10KA)

CHIEF ENGINEER/PROJECTS
 APTRANSCO/VS/VIJAYAWADA

39	40	41	42	43	44	45	46	47	48	49
BTS(+)	Blank	BTS(+)	RS-485A	RS-485B	Blank	Blank	LFL-S	HWT-S	LLOP-S	

TEC-9900-C

Bat(-Ve)	Bat(+Ve)	DC O/P A	DC O/P B	DC O/P C	DC O/P E	Crank	Solenoid	Blank	Digital I/P A	Digital I/P B	Digital I/P C	Digital I/P D	Digital I/P E	Digital I/P F	Digital I/P G	Digital I/P H	Digital I/P I	Digital I/P J	Act/Manual	CAN - L	CAN - H		
1	2	3	4	5	6	7	8	9	10	11	12	13	14	15	16	17	18	19	20	21	22	23	24

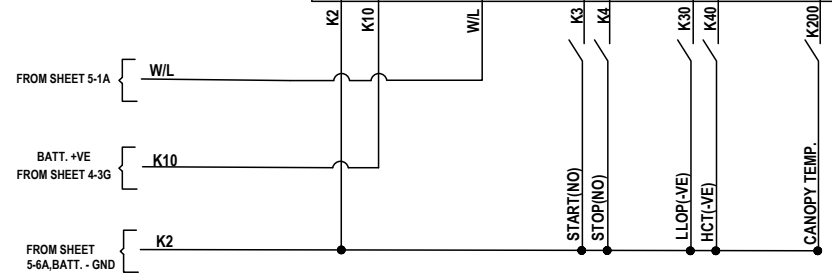

NEW RELEASE		12/08/19	BKM	SA
R.NO.	DR NO.	DESCRIPTION (LOCATION)	DATE	CHANGED BY APPD. BY
TMTL	CRITICAL CHARACTERISTIC	PART NO.	DR. NO.	
	SIGNIFICANT CHARACTERISTIC	PART NAME		
SHEET DESCRIPTION:				
AC CIRCUIT				
DRAWING NO.	AL 1715	REV.	QTY.	1
			SCALE	NTS
			Vt (Kg)	
			S.A. (mm)	
DRAWN	BKM	DATE:	12/08/19	
CHKD	SA	DATE:	12/08/19	
APPD	SA	DATE:	12/08/19	

ALL DIMENSIONS ARE IN mm UNLESS SPECIFIED

NOTE: 1. Drawings Approval subject to valid type test reports, to be checked during acceptance tests.
 2. For EPC contractors only.

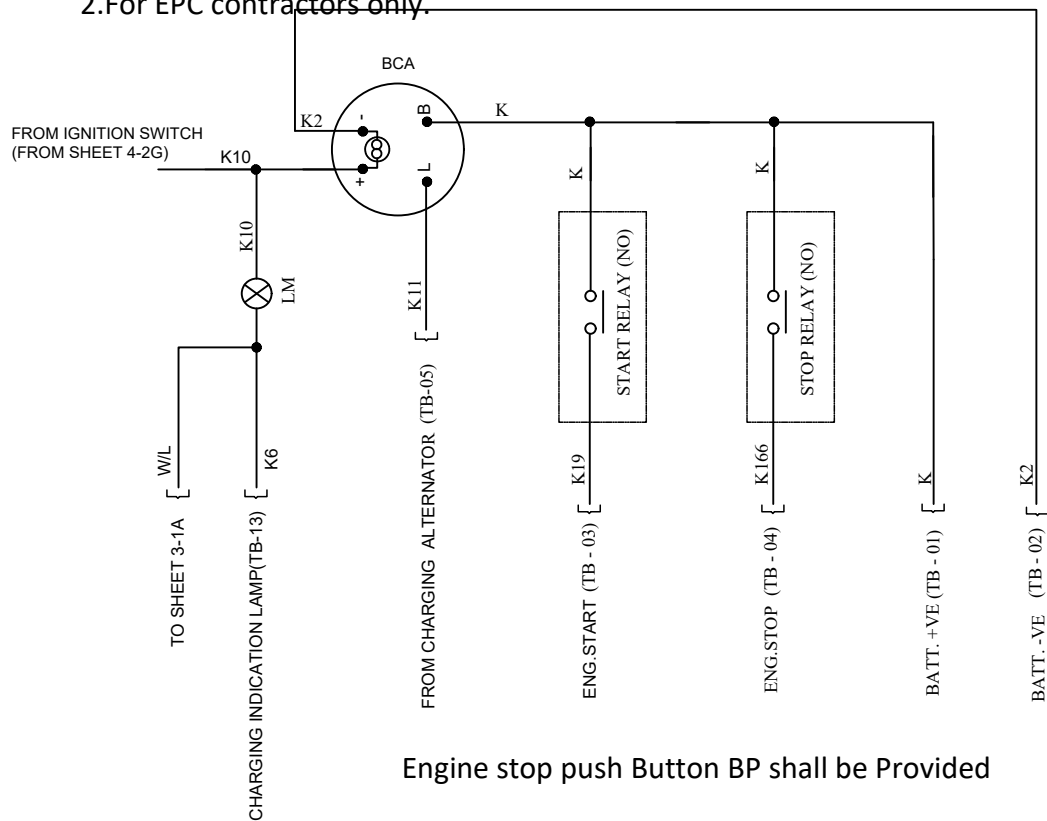

Engine stop push Button BP shall be Provided

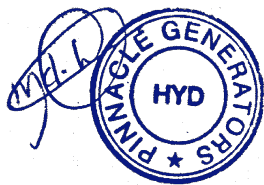

CHIEF ENGINEER/PROJECTS
 APTRANSCO/VS/VIJAYAWADA

NOTE:

1. IN "MANUAL START - AUTO STOP MODE", MAINS SENSING TO BE PROVIDED
2. IN "AUTO START - AUTO STOP" MODE, MAKE SURE THAT THE DG SET STARTS AT NO-LOAD AND STOPS AT NO LOAD AFTER COOL-DOWN TIME.
3. "ATS" OR "AUTO CHANGEOVER MECHANISM" TO BE INCORPORATED AT SITE FOR AUTO LOAD CHANGEOVER .

TERMINAL BLOCK CONNECTIONS

K	01	(+Ve)	FROM BATTERY
K2	02	(-Ve)	
K19	03	ENGINE START	4 SQ. MM WIRES TO BE USED
K166	04	ENGINE STOP	
K11	05	FROM CHARG.ALT.	1.5 SQ. MM WIRES TO BE USED
K30	06	LLOP SWITCH	
K40	07	HCT SWITCH	CONTROL WIRES
K16	08	EMERGENCY STOP	
W	09	ALT. W POINT/BF (Only for EGR Engines)	CONTROL WIRES
K43	10	LLOP SENSOR	
K53	11	FUEL FLOAT	CONTROL WIRES
K10A	12	CANOPY LIGHT	
K6	13	TO BATT.CHARGING LAMP	CONTROL WIRES
K32	14	HCT SENSOR	
K200	15	CANOPY TEMP.	CONTROL WIRES
E11B	16	TO EX. FAN	
EN	17		CONTROL WIRES
K2	18	BATTERY -VE	
M10	19	R	FOR AUTO STOP, PROVIDE MAINS INPUT AT THE TERMINALS SHOWN. FOR 3P - RYBN (415 VAC, TPN FROM MAINS)
M30	20	Y	
M50	21	B	
MN	22	N	
42A	23	RS-485 PORT (OPTIONAL)	
43B	24		

NEW RELEASE		12/08/19	BKM	SA
RND	DR	ND	CHANGED BY	APPD
DESCRIPTION (LOCATION)		DATE	CHANGED BY	APPD
TMTL SHEET DESCRIPTION: CONTROL CIRCUIT AND TB		PART NO.	15KVA,3PHASE,MCP	DR. NO.
MATERIAL		---	---	---
DRAWING NO		AL 1715	REV	1
SCALE		---	---	NTS
Vt. (Kg)		---	---	---
S.A. (mm)		---	---	---
DRAWN	BKM	DATE	12/08/19	
CHKD	SA	DATE	12/08/19	
APPD	SA	DATE	12/08/19	
ALL DIMENSIONS ARE IN mm UNLESS SPECIFIED				

NOTE: 1. Drawings Approval subject to valid type test reports, to be checked during acceptance tests.
 2. For EPC contractors only.

Drawing approval subject to valid vendor registration

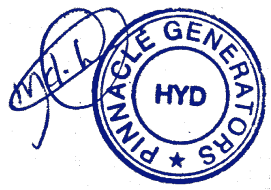

CHIEF ENGINEER/PROJECTS
APTRANSCO/VS/VIJAYAWADA

Engine stop push Button BP shall be Provided

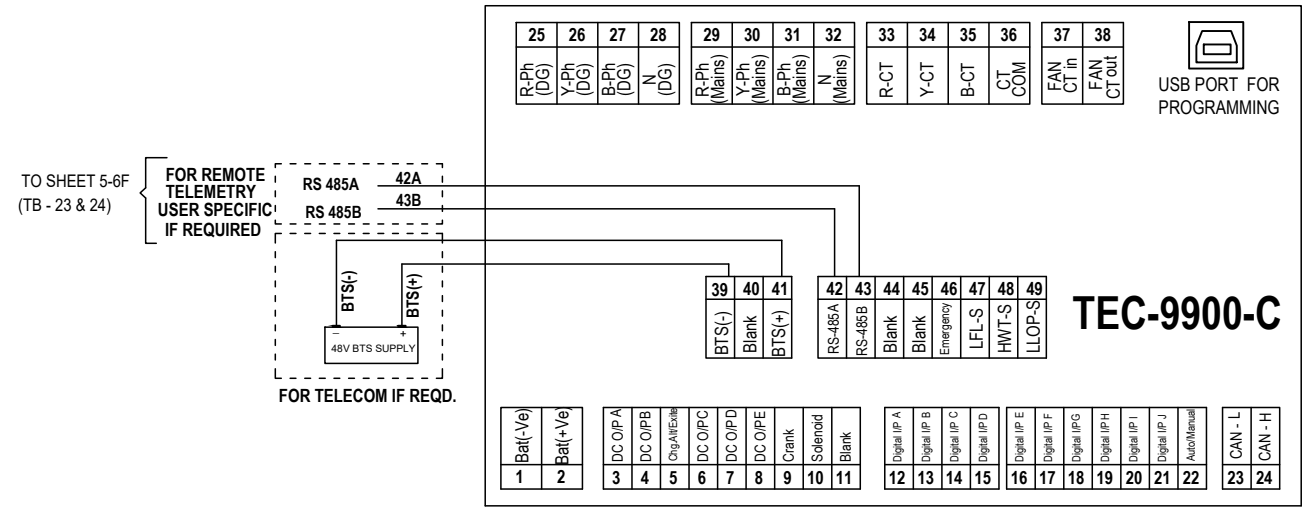

The following notice to be pasted on the Engine in a sticker form
 "RAKSHAK OIL SAE 15W40 APICF4 GRADE to be used as lubricating oil lub oil sump capacity 9.5ltrs".

NEW RELEASE		11/09/19	BKM	SA
R/NO	DR NO.	DESCRIPTION (LOCATION)	DATE	CHANGED BY/APPD. BY
TMTL		15KVA,3PHASE,MCP		
SHEET DESCRIPTION:		MATERIAL	REV	QTY.
RS485 AND TELECOM SHEET IF REQUIRED		AL 1715		1
		SCALE	NTS	
		Wt (Kg)		
		SA (MCP)		
DRAWN	BKM	DATE	11/09/19	
CHKD	SA	DATE	11/09/19	
APPD	SA	DATE	11/09/19	

ALL DIMENSIONS ARE IN mm UNLESS SPECIFIED

NOTE: 1. Drawings Approval subject to valid type test reports, to be checked during acceptance tests.

2. For EPC contractors **BILDOY MATERIAL - 15 KVA - MCP PANEL**

SR. NO.	ABB	DESCRIPTION	MAKE	SPECIFICATIONS	QUANTITY
1	CPS	CONTROL PANEL SHELL		W=550MM,H=270MM,D=175MM	1 NO.
2	GCU	GENSET CONTROLLER UNIT		MICROPROCESSOR BASED	1 NO.
3	MCB	MCB- POWER CIRCUIT		25A, 3P,10KA, C-CURVE	1 NO.
4	CT	CURRENT TRANSFORMER		75/5 CL1,2.5VA	3 NOS.
5	BC	STATIC BATTERY CHARGER SMPS BASED		12V DC,10A, INPUT 100-230VAC,WITH REVERSE POLARITY PROTECTION	1 NO.
6	WL	WARNING LAMP/ CHARGE INDICATOR		2W, 12V DC	1 NO.
7	CHA	DC CHARGING AMPERE METER		-30 TO +30 AMPS	1 NO.
8	KEY.SW	IGNITION KEY		3-POSITION ON,OFF,START WITH SPRING RETURN	1 NO.
9	CR	CRANK RELAY		12V DC COIL - 30A - 1NO & 1NC,DUAL HL OR 70A SINGLE CONTACT	1 NO.
10	SR	STOP RELAY		12V DC COIL - 30A - 1NO & 1NC,DUAL HL OR 70A SINGLE CONTACT	1 NO.
11	F	GLASS FUSE WITH HOLDER		(4-6) AMPS	6 NOS.
12	TS	CANOPY LIGHT ON/OFF SW.		ON/OFF	1 NO.
13	X-1	POWER TERMINAL-DG		63 A,4P,BAKELITE TERMINAL BLOCK WITH PROTECTION CAP	1 NO.
14	X-2	POWER TERMINAL-LOAD		63 A,4P,BAKELITE TERMINAL BLOCK WITH PROTECTION CAP	1 NO.
15	Q1	MCB FOR AC CONTROL CIRCUIT(EXHAUST FAN)		6A,1P, C-CURVE, FOR 230VAC	1 NO.
16	Q2	MCB FOR DC CONTROL CIRCUIT		6A,1P, C-CURVE, FOR 12VDC	1 NO.
17		POWER CABLE RED(FOR R-PHASE)		6 SQ MM, 1CORE, MULTISTRAND, PVC SHEATH,HRFR	1 NO.
18		POWER CABLE YELLOW(FOR Y-PHASE)		6 SQ MM, 1CORE, MULTISTRAND, PVC SHEATH,HRFR	1 NO.
19		POWER CABLE BLUE(FOR B-PHASE)		6 SQ MM, 1CORE, MULTISTRAND, PVC SHEATH,HRFR	1 NO.
20		POWER CABLE NEUTRAL(FOR N-PHASE)		6 SQ MM, 1CORE, MULTISTRAND, PVC SHEATH,HRFR	1 NO.
21		TERMINAL BLOCKS		2.5 SQ MM,SCREW TYPE DIN RAIL MOUNTING	14 NO.
22		TERMINAL BLOCKS		4 SQ MM,SCREW TYPE DIN RAIL MOUNTING	5 NO.
23		WIRE CHANNEL		25X40MM,PVC	1 SET
24		LUGS		AS PER CIRCUIT	1 SET.
25		DOOR LOCK		AS PER REQ.	1 NO.
26		COPPER WIRE GREY		1.5 SQMM MULTISTRAND, PVC SHEATH,HRFR	1 SET
27		COPPER WIRE RED		4 SQ MM, MULTISTRAND, PVC SHEATH,HRFR	1 SET
28		COPPER WIRE BLACK		4 SQ MM, MULTISTRAND, PVC SHEATH,HRFR	1 SET
29		COPPER WIRE GREEN		2.5 SQ MM, MULTISTRAND, PVC SHEATH,HRFR	1 SET
30		DIN RAIL		AS PER CIRCUIT	1 SET
31		LOCK DIN RAIL		DIN RAIL MOUNTING	5 NOS.
32		NYLON SPIRAL		10MM WIDE	1 SET

Engine stop push Button BP shall be Provided

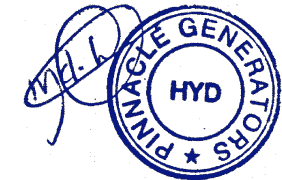

**CHIEF ENGINEER/PROJECTS
APTRANSCO/VISVIJAYAWADA**

The following notice to be pasted on the Engine in a sticker form

“RAKSHAK OIL SAE 15W40 APICF4 GRADE to be used as lubricating oil lub oil sump capacity 8 ltrs”.

NEW RELEASE		BIOM	SA
DESCRIPTION (LOCATION)		DATE	CHANGED BY APPD. BY
TMTL	CRITICAL CHARACTERISTIC	PART NO.	---
	SIGNIFICANT CHARACTERISTIC	PART NAME	15KVA,3PHASE,MCP
SHEET DESCRIPTION:		MATERIAL	---
BILL OF MATERIAL		DRAWING NO.	AL 1715 REV
		QTY.	1
		SCALE	NTS
		DATE	11/09/19
		DATE	11/09/19
		DATE	11/09/19

USER MANUAL FOR TMTL AMF CONTROLLER MODEL – TEC-9900C

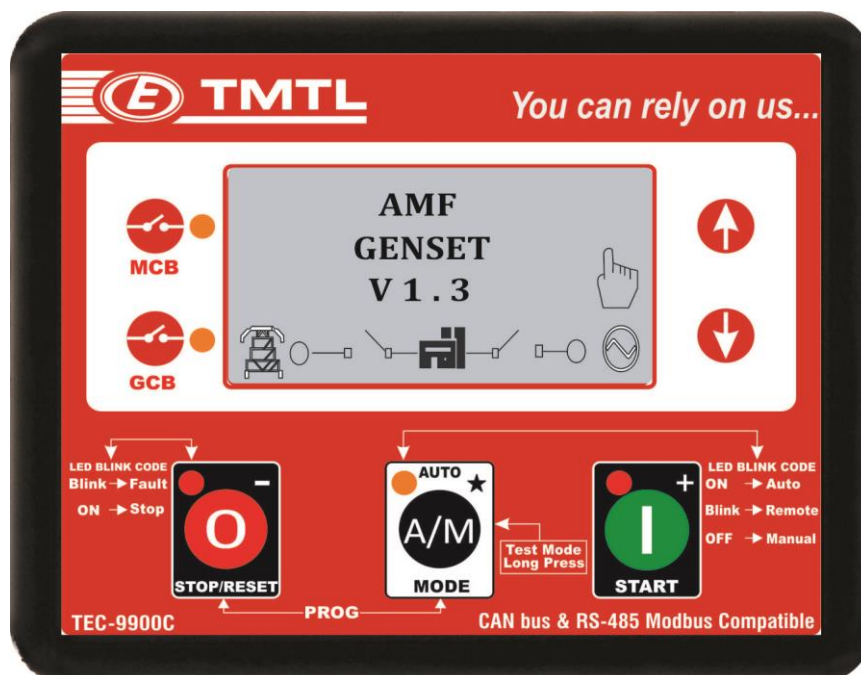

Version – 1.3.1
Release of Date- 14/06/2019

Table of Content

Sr.No.	Description	Page No.
1	Introduction	1
2	Features	1
3	Front Panel Configuration	1
4	Push Button	2
5	Display Parameter	2-3
6	Specification- LED	4
7	Action on Faults	4-5
8	Description of Programming Parameter	5-6
9	Fault and Event History Details	7
10	Operation	7-8
11	Programming Parameters	
	A) Configuration Parameters – Timer (Page-1)	9
	B) Configuration Parameters – Generator (Page-2)	10-11
	C) Configuration Parameters – Mains (Page-3)	12-13
	D) Configuration Parameters – Engine (Page-4)	13-14
	E) Configuration Parameters – Digital Inputs (Page-5)	14-16
	F) Configuration Parameters – Analogue Inputs (Page-6)	16-17
	G) Configuration Parameters – Output (Page-7)	17-18
	H) Configuration Parameters – (Page-8)	18
	I) Configuration Parameters – Maintenance (Page-9)	18-19
J) Configuration Parameters – Scheduler (Page-10)	19-20	
12	AC System	20
13	Digital Input Polarity	20
14	Digital Output Polarity	20
15	Action	20
16	Activation	21
17	Input Sources	21

7591765/2023/EEMRT-ENE51

18	Output Sources	22
19	Instrumentation Icons	23
20	MODE ICON	23
21	LOAD SWITCHING ICON	23
22	WARNING ALARM ICONS	24
23	ELECTRICAL TRIP ALARM ICONS	24
24	SHUTDOWN ALARM ICONS	24-25
25	Communication Port A) USB Connection	25
26	DO'S AND DON'T	26
27	Dimension	26
28	General characteristics	27
29	Terminal description	28
30	Wiring Diagram for Using Controller in Manual Mode	29
31	Wiring Diagram for Using Controller in Auto Mode	30
32	Monitoring Mode	31-35

Drawing approval subject to valid vendor registration

INTRODUCTION

Smart DG Controller is an advanced 32 bit Micro controller based DG Protection unit and has been specially designed to meet the harsh requirement of Indian conditions.

The TEC-9900C series module has been designed to allow the operator to start and stop the generator, and if required, transfer the load to the generator either manually or automatically. Additionally, the TEC-9900C automatically starts and stops the generator set depending upon the status of the mains (utility) supply & BTS Battery if monitoring Enable.

The TEC-9900C module monitors the engine, indicating the operational status and fault conditions, automatically shutting down the engine and giving a true first up fault condition of an engine failure by the LCD display.

FEATURES





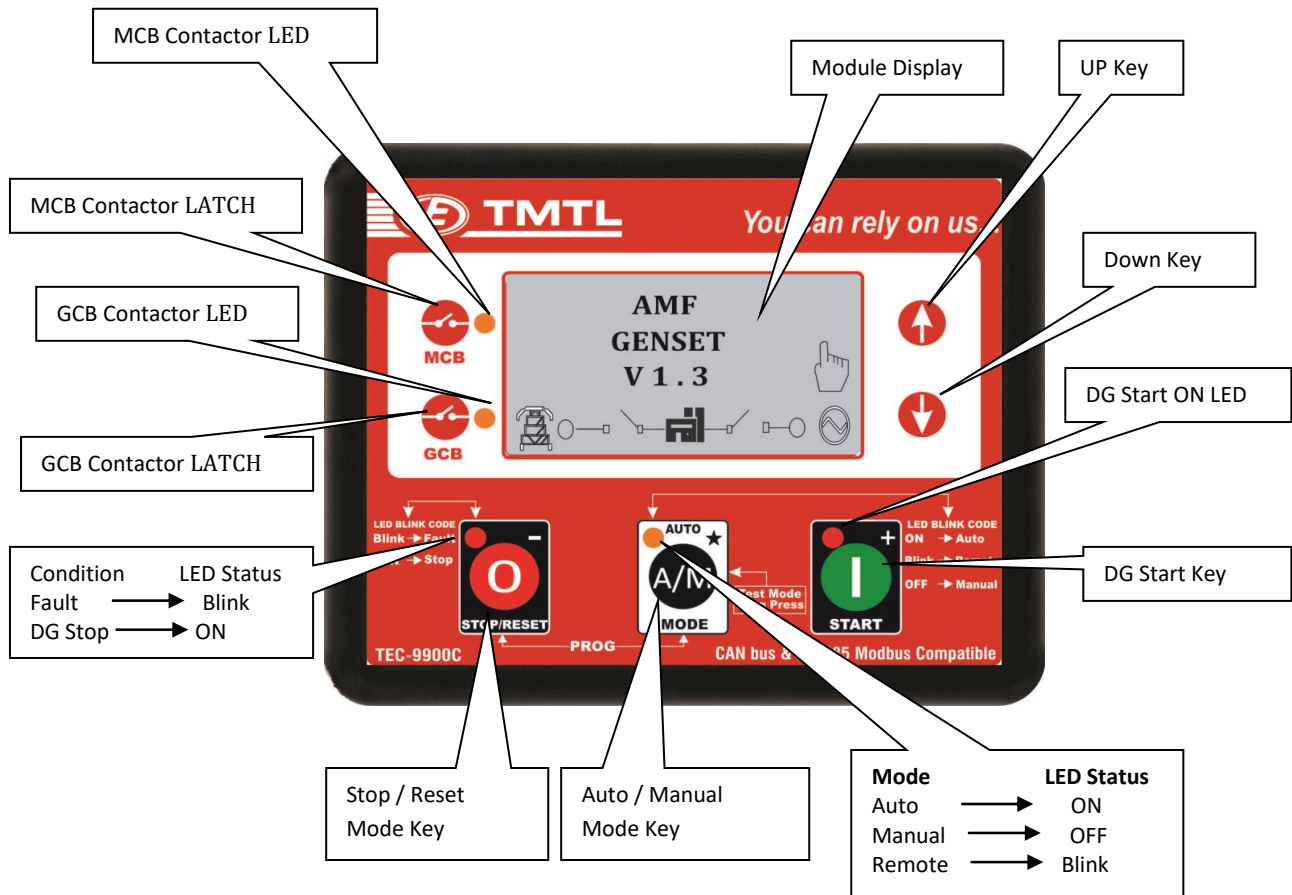

- Micro Controller Based Design
- Compact Size, Elegant Design & Easy Install
- Icon based LCD display
- **True RMS** Voltage
- Current and Power monitoring
- USB Communications
- Engine parameter monitoring.

FRONT PANEL CONFIGURATION





Drawing approval subject to valid vendor registration

PUSH BUTTON

ICON	DESCRIPTION
	<u>STOP/RESET KEY</u> This key is used to Stop DG Set in Manual Mode & Reset if any fault Condition Present.
	<u>AUTO / MANUAL KEY</u> This key is used to select Auto/Manual mode and to select Fault Log Page & P-Codes.
	<u>START KEY</u> This key is used to start the DG Manually.
 	<u>MENU NAVIGATION</u> Both key is used to shift from one Page to another Page in Programming mode and used to enter in Event Log History & P-Codes . (Press both key together) & Scrolling display.
 MCB  GCB	<u>MCB/GCB MODE</u> To Latch Main Contactor in Manual Mode To Latch DG Contactor in Manual Mode.

DISPLAY PARAMETER

Sr.No.	DISPLAY PARAMETER	DESCRIPTION	Display	DISPLAY SCREEN
1	AMF GENSET AMF V1.3	Display Version	Graphical Display	Screen-1
2	000V L1N 000V 000V L2N 000V 000V L3N 000V	Mains & Generator Voltage (L-N)	Graphical Display	Screen-2
3	000V L1L2 000V 000V L2L3 000V 000V L3L1 000V	Mains & Generator Voltage (L-L)	Graphical Display	Screen-3
4	L1N 000V L2N 000V L3N 000V	Generator Voltage (L-N)	Graphical Display	Screen-4
5	L1L2 000V L2L3 000V L3L4 000V	Generator Voltage (L-L)	Graphical Display	Screen-5

6	00.00 Hz	Generator Frequency	Graphical Display	Screen-6
7	L1N 000V L2N 000V L3N 000V	Mains Voltage(L-N)	Graphical Display	Screen-7
8	L1L2 000V L2L3 000V L3L1 000V	Mains Voltage(L-L)	Graphical Display	Screen-8
9	00.00Hz	Mains Frequency	Graphical Display	Screen-9
10	L1 00.00A L2 00.00A L3 00.00A	Load Current (A)	Graphical Display	Screen-10
11	L1 00.00 KW L2 00.00 KW L3 00.00 KW	Active Power (kW)	Graphical Display	Screen-11
12	L1 00.0 KVA L2 00.0 KVA L3 00.0 KVA	Apparent Power (KVA)	Graphical Display	Screen-12
13	L1 0.00 PF L2 0.00 PF L3 0.00 PF	Power Factor	Graphical Display	Screen-13
14	00.00 KW 00.00 KVA 0.00 PF	Combined Active Power Combined Apparent Power Avg. Power Factor	Graphical Display	Screen-14
15	0000.0 kWh 0000.0 kWh	DG kWh Mains kWh	Graphical Display	Screen-15
16	00.00 V 00.00 V	DG Battery Voltage BTS Battery Voltage	Graphical Display	Screen-16
17	00.00 V	Charging Alternator	Graphical Display	Screen-17
18	 Bar	Oil Pressure	Graphical Display	Screen-18
19		Temperature	Graphical Display	Screen-19
20	xxx % 	Fuel Level	Graphical Display	Screen-20
21	000000:00	DG Run Hours.	Graphical Display	Screen-21
22	000000:00	Mains Run Hrs	Graphical Display	Screen-22
23	0000:00	Service Hours	Graphical Display	Screen-23
24	0000	Engine Speed	Graphical Display	Screen-24
25	Location Info 000001	Communication Id	Graphical Display	Screen-25
26	ALARMS	Fault Alarms up to 3	Graphical Display	Screen-26
27	Status	Running Status	Graphical Display	Screen-27
28	XX::XX:XX XX/XX/XX	RTC (Real time Clock)	Graphical Display	Screen-28

SPECIFICATION-LED

Drawing approval subject to valid vendor registration

LED will glow, whenever the corresponding condition is sensed by the controller.















Tag	Color	Status
START	RED	Normal Protected - OFF
		Start Enable - Blink
		DG Start - ON
STOP	RED	Normal - OFF
		DG Stop - ON
		Fault Condition - Blink
AUTO	AMBER	Manual Mode - OFF
		Auto Mode - ON
		Remote Mode - Blink
MCB	AMBER	Mains Contactor - ON
		Manual Mode - OFF
GCB	AMBER	Normal - OFF
		Genset Contactor - ON





















ACTION ON FAULTS

Sr.No.	Name of Faults	Description of Indication
1	FAIL TO START	When after no. of Set attempt , DG not start then FAIL TO START fault occur & Graphical Display
2	LLOP	DG Stop and GCB Contactor OFF & Graphical Display
3	HET	DG Stop and GCB Contactor OFF & Graphical Display
4	RWL	DG Stop and GCB Contactor OFF & Graphical Display
5	LOW FUEL	DG Stop and GCB Contactor OFF & Graphical Display
6	EMERGENCY / CANOPY	DG Stop and GCB Contactor OFF & Graphical Display
7	UNDER/OVER VOLTAGE	DG Stop and GCB Contactor OFF & Graphical Display
8	UNDER / OVER SPEED	DG Stop and GCB Contactor OFF & Graphical Display
9	UNDER /OVER FREQUENCY	DG Stop and GCB Contactor OFF & Graphical Display
10	OVER CURRENT	DG Stop and GCB Contactor OFF & Graphical Display
11	UNBALANCE CURRENT	DG Stop and GCB Contactor OFF & Graphical Display
12	CHARGING ALTERNATOR	DG Stop and GCB Contactor OFF & Graphical Display

13	UNDER / OVER BATTERY	DG Stop and GCB Contactor OFF & Graphical Display
14	OVER ACTIVE POWER(KW)	DG Stop and GCB Contactor OFF & Graphical Display
15	SERVICE DUE	ALARM & Graphical Display

Description of Programming Parameter

Step	Process	Image
1	Press and hold the  and  buttons together to enter the editor mode. Display shows PROGRAMMING MODE PASSWORD 0000	
2	Press  button 1 appear on right side on LCD means first digit from MSB can change from 0-9 by using  button . For Password Enter "1" at first digit. PROGRAMMING MODE PASSWORD 1000 1	
3	Use  button to shift to next digit, now can change value of second digit from 0 to 9 by using  Button and enter "0" and so on. Default Password is 1000 PROGRAMMING MODE PASSWORD 1000 4	
4	After entering '1000' Press  button again. If the entered Password is correct then controller shifts to programming page otherwise the controller shows '0000' and again prompts for entry of password.	
5	Press the  or  navigation buttons to cycle through the front panel editor to select the required page in the configuration tables.	

<p>6</p>	<p>Press the  to select the next parameter or  to select the previous parameter within the current page.</p>	
<p>7</p>	<p>When viewing the parameter to be edited, press the  button, the value begins to flash.</p>	
<p>8</p>	<p>Press the  or  buttons to adjust the value to the required setting</p>	
<p>9</p>	<p>Press the  button to save the current value, the value ceases flashing.</p>	
<p>10</p>	<p>Press and hold the  button to save and exit the editor, the configuration icon  is removed from the display.</p>	
<p>11</p>	<p>If User wants to see Event & Fault History then Press  &  button simultaneously (Long Press) to enter in Event Log & fault history Mode, then can see 210 history by  button. To exit from Event Log History, Long Press both button  &  Simultaneously.</p>	
<p>12</p>	<p>If Engine Selection CAN then Enter Password "1717" as per above step, User can see CAN Parameter -</p> <ul style="list-style-type: none"> • Fuel Rate • Fuel Pressure • Oil Temp. • Engine Intake manifold temperature 	

Fault & Event History Details -

<u>Range</u>	<u>Faults</u>
1 to 50	DG Faults
51 to 100	Engine Faults
101 to 150	Start/Stop Event
151 to 200	Mains Event
201 to 210	Fuel Log

Operation -

Auto Mode - To Enter into Auto mode press  key. When the mains unhealthy condition occurs, first Mains Restoration Delay timer is initiated and genset will be cranked at the end of this delay. Controller will latch the genset contactor when genset loading voltage and frequency are above the Minimum Healthy thresholds after the warm-up time is over. Engine run hours will start incrementing when the genset voltage becomes greater than Minimum Healthy Voltage. During genset running, if the mains voltage returns, Return to Mains Delay timer starts. If the mains voltage is healthy over the entire return delay duration, genset contactor gets opened and controller will initiate the stopping sequence and latch the mains contactor after transfer delay.

During start sequence, if the mains voltage recovers or any stop command or shutdown / warning alarm occurs controller will not issue start command. To start the genset it is necessary to clear all the alarms manually and put the controller in Auto mode.

Manual Mode – In this mode start and stop key use for starting and stopping DG set. Similarly generator and Mains contactors can latched by MCB switch & Genset contactor can latched By GCB Switch.
1) MCB and GCB key

Test Mode - At long press Auto Key  enter in test mode. In test mode all LED's (MCB, GCB, STOP, AUTO, START) glow for 5 Sec . In Test Mode when Manually DG Start then DG ON and Manually DG Stop then DG Stop if Test Mode timer 0 set. If Test Mode Timer set any value then DG Start manually & DG continue run for "Test mode timer".
During Test Mode MCB & GCB Contactor doesn't work .

Remote Mode-

To use Remote mode, follow below points
1) Configure one one digital input as "Remote"
2) Put controller in Auto mode

In that case if negative present at configurable digital input, controller activate crank relay for "crank time". DG continue run till Negative present at input and Latch genset contactor. If mains become healthy contactor shift to mains and stop dg set.

Engine Selection -

If Conventional Engine is selected – Display of High Engine Temperature show in bar graph format. Up to 7 bar display show OK after 7 bar (8 bar) display show NOT OK. Tripping of DG SET depend only on Temperature Switch.

If CAN Engine is selected – Display of HET Temperature show in digital format receive from CAN BUS. Tripping of DG SET depend on Digital value and Temperature Switch. If Digital Value of Temp. is grater then Set Value (Parameter 632) than DG STOP Command Trigger.

Communication Failure:-

RS-485 communications enable/disable option provided in parameter setting at 805.

If Disable (0-non GPRS site) selected in parameter setting at 805 than there will no alarm show on display either Modem or Modbus connected or not connected.

If Enable (1-GPRS site) selected in parameter setting at 805 than there are two type of alarm show on controller if communication break.

1) COMM fail "alarm show on display if communication fail b/w controller (TEC-9900C) and Modem/Modbus.

2) "Network Failure" alarm show on display if communication fails b/w Modem and server.

Current Unbalance Detection:-

- A) Controller doesn't take any action till the current is below 25% of the Over current Set Limit in three Phase.
- B) Controller Monitors the Current and upon any phase current exceeding 25% compares it with other phase currents and if the difference between max current and other phase current exceed set value in % defined then controller consider it as a current unbalance condition.
- C) In case the current unbalance persists for a period greater than the limit specified by with default setting of programmable parameters and between 1-99 minutes, then controller issues STOP Command.
- D) The Default setting for this feature is "DISABLE".

Charging Alternator Type:

If Chg. Alternator Type (Parameter no. 430) = 0 , Sense Signal from W Point.

If Chg. Alternator Type (Parameter no. 430) = 1, Controller Provide Excitation from terminal no. 5 (Chg. Alt/Excite) for 10 sec. when DG Start.

If Chg. Alternator Type (Parameter no. 430) = 2 , Controller Provide Excitation from terminal no. 5 (Chg. Alt/Excite) Continuously , when DG Start.

Rotary Switch:

If "Rotary Switch Enable" (Parameter 920) is 1 in editable parameter than Auto/Manual selection only can do through connector Pin no.22 If 12V applied at Pin no. 22 than Controller shift in Auto Mode. If 0 applied or Open than controller remains in manual Mode.

Auto Load Transfer: This function only applicable in Manual Mode.

If "Auto Load Transfer" (Parameter -243) is 1 than shifting of contactors method change in Manual mode. In this Mode DG Contactor on high priority. If someone start the DG manually, than DG Contactor Latch either Mains Healthy or Fail.

CT On Load: - Measure energy of Mains & DG both depends on Contactor.

CT On DG: - Only Measure DG Energy.

PROGRAMMING PARAMETERS**Configuration Parameters – TIMERS (Page 1)**

INDEX	SETTABLE PARAMETER	RANGE	DEFAULT
101	MAINS RESTORATION TIME	0-99 s	10 s
102	PRE HEAT TIME	0-999 s	001 s
103	CRANK TIME	0-20 s	03 s
104	CRANK REST TIME	0-99 s	10 s
105	WARM UP TIME	0-99 s	10 s
106	COOLING TIME	0-999 s	010 s
107	STOP TIME	0-99 s	30 s
108	MCB_GCB CHANGE OVER TIME	0-99 s	01 s
109	BUZZER TIME	0-99 s	60 s
110	LLOP BYPASS TIME	0-99 s	10 s
111	POWER SAVER MODE TIME	0-99 s	60 s
112	FUEL LOGGING TIME	0-99 s	99 s
113	SAFETY MONITOR DELAY	0-99 s	10 s
114	ALTERNATOR DETECT DELAY	0-99 s	05 s
115	RETURN TO MAINS DELAY	0-999 s	10 s
116	MAINS TRANSIENT DELAY	0-99 s	10 s
117	GENERATOR TRANSIENT DELAY	0-99 s	10 s
118	AUTO START DELAY	0-99 s	1 s
119	MANUAL START DELAY	0-99 s	2 s
120	ADDITIONAL STOP TIMER	0-99 s	10 s
121	TEST MODE TIMER	0-999 s	000 s
122	SCREEN SCROLL TIMER	0-99 s	10 s

Configuration Parameters – Generator (Page 2)

INDEX	SETTABLE PARAMETER	RANGE	DEFAULT
201	ALTERNATOR PRESENT	YES	YES
202	ALTERNATOR POLES	0- 36	04
203	DG PICKUP VOLTAGE	0-240V	80V
204	DG PICKUP FREQUENCY	20 -50 HZ	30HZ
205	DG PHASE DETECT	On(1) , Off(0)	Off (0)
206	DG PHASE REVERSAL ACTION	0-3	3
207	ENGINE UNDER VOLTAGE TRIP ENABLE	On (1), Off (0)	On(1)
208	ENGINE UNDER VOLTAGE TRIP LEVEL	80-240V	180 V
209	ENGINE UNDER VOLTAGE WARNING ENABLE	On (1), Off (0)	Off (0)
210	ENGINE UNDER VOLTAGE WARNING LEVEL	80-240V	200 V
211	ENGINE UNDER VOLTAGE ACTION DELAY	0-99s	10s
212	ENGINE OVER VOLTAGE WARNING ENABLE	On (1), Off (0)	On(1)
213	ENGINE OVER VOLTAGE WARNING RETURN	200-350V	260 V
214	ENGINE OVER VOLTAGE WARNING ALARM	200-350V	270 V
215	ENGINE OVER VOLTAGE TRIP LEVEL	200-350V	280 V
216	ENGINE OVER VOLTAGE ACTION DELAY	0-99s	10s
217	ENGINE UNDER FREQUENCY TRIP ENABLE	On (1), Off (0)	On(1)
218	ENGINE UNDER FREQUENCY TRIP LEVEL	45-50 Hz	47.5Hz

219	ENGINE UNDER FREQUENCY WARNING ENABLE	On (1), Off (0)	Off (0)
220	ENGINE UNDER FREQUENCY WARNING LEVEL	40-50 Hz	48 Hz
221	ENGINE UNDER FREQUENCY ACTION DELAY	0-99s	10s
222	ENGINE OVER FREQUENCY WARNING ENABLE	On (1), Off (0)	On(1)
223	ENGINE OVER FREQUENCY WARNING RETURN	50-60 Hz	53.0 Hz
224	ENGINE OVER FREQUENCY WARNING LEVEL	50-60 Hz	53.5 Hz
225	ENGINE OVER FREQUENCY TRIP ENABLE	On (1), Off (0)	On(1)
226	ENGINE OVER FREQUENCY TRIP LEVEL	50-60 Hz	53.5 Hz
227	ENGINE OVER FREQUENCY ACTION DELAY	0-99s	10s
228	CT PRIMARY	0-9999	0005
229	AMPERE LOAD RATING (PER PHASE)	0-9999A	05A
230	OVER AMPERE TRIP ENABLE	On (1), Off (0)	On(1)
231	OVER AMPERE ACTION SELECT	0-3	0
232	OVER AMPERE DELAY TIME	0-9999s	010s
233	OVER AMPERE TRIP PERCENTAGE	5-200%	100%
234	UNBALANCE AMPERE TRIP ENABLE	On (1), Off (0)	Off(0)

235	UNBALANCE AMPERE ACTION SELECT	0-3	3
236	UNBALANCE AMPERE DELAY TIME	0-9999s	010s
237	UNBALANCE AMPERE TRIP PERCENTAGE	5-200%	50%
238	KW LOAD RATING (TOTAL)	0-9999 KW	4KW
239	OVER KW TRIP ENABLE	On (1), Off (0)	On(1)
240	OVER KW ACTION SELECT	0-3	0
241	OVER KW ACTION LEVEL PERCENTAGE	50-150%	100 %
242	OVER KW DELAY TIME	0 -9999 s	010s
243	AUTO LOAD TRANSFER ENABLE	On (1), Off (0)	Off (0)

Configuration Parameters – Mains (Page 3)

INDEX	SETTABLE PARAMETER	RANGE	DEFAULT
301	MAINS AC SYSTEM CONFIGURATION	0-3	0
302	MAINS FAILURE DETECTION ENABLE	On (1), Off (0)	On(1)
303	MAINS PHASE REVERSAL	On(1), Off(0)	Off(0)
304	MAINS UNDER VOLTAGE ENABLE	On (1), Off (0)	On(1)
305	MAINS UNDER VOLTAGE TRIP VOLTAGE LEVEL	80-240 V	180 V
306	MAINS UNDER VOLTAGE RETURN VOLTAGE LEVEL	80-240 V	190 V
307	MAINS UNDER VOLTAGE TRIP OCCURRENCE DELAY	0 -99s	10s
308	MAINS OVER VOLTAGE ENABLE	On (1), Off (0)	On(1)
309	MAINS OVER VOLTAGE RETURN VOLTAGE LEVEL	150-350 V	260 V
310	MAINS UNDER VOLTAGE TRIP VOLTAGE LEVEL	150-350 V	270 V
311	MAINS OVER VOLTAGE OCCURRENCE DELAY	0 -99s	10 s
312	MAINS UNDER FREQUENCY ENABLE	On (1), Off (0)	On(1)
313	MAINS UNDER FREQUENCY TRIP LEVEL	40-50 Hz	48 Hz

314	MAINS UNDER FREQUENCY RETURN LEVEL	40-50 Hz	48.5Hz
315	MAINS UNDER FREQUENCY OCCURRENCE DELAY	0 -99s	10 s
316	MAINS OVER FREQUENCY ENABLE	On (1), Off (0)	On(1)
317	MAINS OVER FREQUENCY RETURN LEVEL	50-60 Hz	53.0 Hz
318	MAINS OVER FREQUENCY TRIP LEVEL	50-60 Hz	54.0 Hz
319	MAINS OVER FREQUENCY OCCURRENCE DELAY	0 -99s	10 s

Configuration Parameters – Engine (Page 4)

INDEX	SETTABLE PARAMETER	RANGE	DEFAULT
401	Engine Selection	Can/Conventional	CAN
402	ENGINE START ATTEMPT	0 -99	3
403	DG START PROTECTION	On (1), Off (0)	Off (0)
404	DG STOP SWITCH COOL DOWN	On (1), Off (0)	On (1)
405	CRANK DISCONNECT OIL PRESSURE ENABLE	On (1), Off (0)	Off (0)
406	CRANK DISCONNECT OIL PRESSURE LEVEL	0-10	1.0
407	CRANK DISCONNECT FREQUENCY LEVEL	40-50Hz	40 Hz
408	CRANK DISCONNECT RPM LEVEL	500-1500	500
409	MONITORING PRESSURE SWITCH BEFORE	On (1), Off (0)	On (1)
410	MONITORING PRESSURE SENSOR BEFORE	On (1), Off (0)	Off (0)
411	DISCONNECT CRANK LLOP	On (1), Off (0)	Off (0)
412	DISCONNECT CRANK CHG. ALTE	On (1), Off (0)	Off (0)
413	DISCONNECT LEVEL CHARGING ALTERNATOR	5.0-30.0	5.0
414	ENGINE SPEED SENSE	ALTERNATOR	ALTERNATOR
415	DG UNDER RPM ENABLE	On (1), Off (0)	On (1)
416	DG UNDER RPM TRIP LEVEL	1200-1500	1400
417	DG UNDER RPM TRIP DELAY	0-99s	10s
418	DG OVER RPM TRIP LEVEL	1500-1800	1600
419	DG OVER RPM TRIP DELAY	0 -99s	10s
420	GROSS OVER SPEED THRESHOLD	100-200	120%
421	DG LOW BATTERY ACTION	0-3	2
422	ENGINE LOW BATTERY TRIP VOLTAGE LEVEL	8-12V	11.0
423	ENGINE LOW BATTERY RETURN VOLTAGE LEVEL	8-12V	11.2
424	DG LOW BATTERY DELAY	0 -999s	010s
425	DG HIGH BATTERY ACTION	0-3	2
426	DG HIGH BATTERY RETURN LEVEL VOLT LEVEL	12-18V	15V
427	DG HIGH BATTERY TRIP LEVEL	12-18V	16 V

7591765/2023/EEMRT-ENE51

428	DG HIGH BATTERY DELAY	0 -999s	010s
429	DG CHARGING ALTERNATOR ACTION	0-3	1
430	DG CHARGING ALT. TRIP LEVEL	5-20V	5V
431	DG CHARGING ALTERNATOR DELAY	0-99	10 s
432	DG CHARGING ALTERNATOR TYPE	0-2	0
433	FAN FAULT ENABLE	On (1), Off (0)	On (1)
434	FAN TRIP DELAY	0-99	10 s
435	PREHEAT TEMPERATURE ENABLE	On (1), Off (0)	Off (0)
436	PREHEAT TEMPERATURE ENABLE LEVEL	10-300 ⁰	25 ⁰
437	DG START SENSE ENABLE	0-999	000

Configuration Parameters – Digital Inputs (Page 5)

INDEX	SETTABLE PARAMETER	RANGE	DEFAULT
501	DIGITAL INPUT A SOURCE (As Per Input Source-A Table)	0-20	LLOP
502	DIGITAL INPUT A POLARITY	On (1), Off (0)	Off (0)
503	DIGITAL INPUT A ACTION	0-3	1
504	DIGITAL INPUT A ACTIVATION	0-3	2
505	DIGITAL INPUT A DELAY	0 -999 s	10s
506	DIGITAL INPUT B SOURCE (As Per Input Source-A Table)	0-20	HWT
507	DIGITAL INPUT B POLARITY	On (1), Off (0)	Off (0)
508	DIGITAL INPUT B ACTION	0-3	1
509	DIGITAL INPUT B ACTIVATION	0-3	2
510	DIGITAL INPUT B DELAY	0 -999 s	10s
511	DIGITAL INPUT C SOURCE (As Per Input Source-A Table)	0-20	LFL
512	DIGITAL INPUT C POLARITY	On (1), Off (0)	Off (0)
513	DIGITAL INPUT C ACTION	0-3	1
514	DIGITAL INPUT C ACTIVATION	0-3	3
515	DIGITAL INPUT C DELAY	0 -999 s	10s
516	DIGITAL INPUT D SOURCE (As Per Input Source-A Table)	0-20	HFL
517	DIGITAL INPUT D POLARITY	On (1), Off (0)	Off (0)
518	DIGITAL INPUT D ACTION	0-3	2
519	DIGITAL INPUT D ACTIVATION	0-3	2
520	DIGITAL INPUT D DELAY	0 -999s	10s

7591765/2023/EEMRT-ENE51

521	DIGITAL INPUT E SOURCE (As Per Input Source-A Table)	0-20	RWL
522	DIGITAL INPUT E POLARITY	On (1), Off (0)	Off (0)
523	DIGITAL INPUT E ACTION	0-3	1
524	DIGITAL INPUT E ACTIVATION	0-3	2
525	DIGITAL INPUT E DELAY	0 -999s	10s
526	DIGITAL INPUT F SOURCE (As Per Input Source-A Table)	0-20	CANOPY
527	DIGITAL INPUT F POLARITY	On (1), Off (0)	Off (0)
528	DIGITAL INPUT F ACTION	0-3	1
529	DIGITAL INPUT F ACTIVATION	0-3	2
530	DIGITAL INPUT F DELAY	0 -999s	10s
531	DIGITAL INPUT G SOURCE (As Per Input Source-A Table)	0-20	FIRE & SMOKE
532	DIGITAL INPUT G POLARITY	On (1), Off (0)	Off (0)
533	DIGITAL INPUT G ACTION	0-3	1
534	DIGITAL INPUT G ACTIVATION	0-3	3
535	DIGITAL INPUT G DELAY	0 -999s	5
536	DIGITAL INPUT H SOURCE (As Per Input Source-A Table)	0-20	Door Open
537	DIGITAL INPUT H POLARITY	On (1), Off (0)	Off (0)
538	DIGITAL INPUT H ACTION	0-3	1
539	DIGITAL INPUT H ACTIVATION	0-3	3
540	DIGITAL INPUT H DELAY	0 -999s	10s

541	DIGITAL INPUT I SOURCE (As Per Input Source-A Table)	0-20	Lamp Test
542	DIGITAL INPUT I POLARITY	On (1), Off (0)	Off (0)
543	DIGITAL INPUT I ACTION	0-3	1
544	DIGITAL INPUT I ACTIVATION	0-3	3
545	DIGITAL INPUT I DELAY	0 -999s	1s
546	DIGITAL INPUT J SOURCE (As Per Input Source-A Table)	0-20	V-Belt Fail
547	DIGITAL INPUT J POLARITY	On (1), Off (0)	Off (0)
548	DIGITAL INPUT J ACTION	0-3	1
549	DIGITAL INPUT J ACTIVATION	0-3	2
550	DIGITAL INPUT J DELAY	0 -999s	10s
551	DIGITAL INPUT K SOURCE (As Per Input Source-A Table)	0-20	Emergency
552	DIGITAL INPUT K POLARITY	On (1), Off (0)	Off (0)
553	DIGITAL INPUT K ACTION	0-3	1
554	DIGITAL INPUT K ACTIVATION	0-3	3
555	DIGITAL INPUT K DELAY	0 -999s	2s

Configuration Parameters – Analogue Inputs (Page 6)

<i>INDEX</i>	<i>SETTABLE PARAMETER</i>	<i>RANGE</i>	<i>DEFAULT</i>
601	ANALOGUE INPUT A SENSOR TYPE	LLOP	LLOP
602	ANALOGUE INPUT A SENSOR SELECTION	Eicher ,User	Eicher
603	ANALOGUE INPUT A LOW OIL PRESSURE ENABLE	On (1), Off (0)	On (1)
604	ANALOGUE INPUT A LOW OIL PRESSURE TRIP POINT	0-10	1.0
605	LLOP WARNING ENABLE	On (1), Off (0)	Off (0)

606	LLOP WARNING THRESHOLD	0-10	1.0
607	ANALOGUE INPUT A LOW OIL PRESSURE OPEN ENABLE	On (1), Off (0)	Off (0)
608	ANALOGUE INPUT A OIL PRESSURE DELAY	0-99s	10s
609-628	RESISITANCE R1 TO R10	0-1000E	AS PER SPECS. SHEET
609-628	PRESSURE P1 TO P10	0-10 BAR	AS PER SPECS. SHEET
629	ANALOG SENSOR TYPE	HET	HET
630	ANALOGUE INPUT B SENSOR SELECTION	WC 0 AC-1 1 AC-2 2 User Defined	WC
631	ANALOGUE INPUT B TEMPERATURE ENABLE	On (1), Off (0)	On (1)
632	ANALOGUE INPUT B TEMPERATURE TRIP POINT	50-200	120
633	ANALOGUE INPUT B TEMPERATURE OPEN ENABLE	On (1), Off (0)	Off (0)
634	ANALOGUE INPUT B TEMPERATURE DELAY	0-99s	10s
635-654	RESISITANCE R1 TO R10	0-1000E	AS PER SPECS. SHEET
635-654	TEMPERATURE T1 TO T10	0-300 °	AS PER SPECS. SHEET
655	ANALOGUE INPUT C SENSOR TYPE	LFL	LFL
656	ANALOGUE INPUT C SENSOR SELECTION	0-1000Ω ,USER DEFINED	10-200Ω
657	ANALOGUE INPUT C SENSOR LFL ENABLE	On (1), Off (0)	On (1)
658	ANALOGUE INPUT C SENSOR LFL TRIP POINT	0-100	10%
659	ANALOGUE INPUT C SENSOR OPEN ENABLE	On (1), Off (0)	Off (0)
660	LOW FUEL LEVEL WARNING ENABLE/DISABLE	On (1), Off (0)	On (1)
661	LOW FUEL LEVEL WARNING THRESHOLD	0-100	20
662	FUEL TANK CAPACITY (LITRE)	0-1000	0180
663	FUEL THEFT ALARM ENABLE	On (1), Off (0)	Off (0)
664	FUEL THEFT THRESHOLD %	0-99 PER	50
665	FUEL CONSUMPTION (LTR/HR)	0 - 99.9	2.5
666	ANALOGUE INPUT C SENSOR LFL DELAY	0-99s	10s
667-686	RESISTANCE	0-1000 E	AS PER SPECS. SHEET
668-686	FUEL LEVEL	0-100 %	AS PER SPECS. SHEET

Configuration Parameters – Output (Page 7)

INDEX	SETTABLE PARAMETER	RANGE	DEFAULT
701	DIGITAL OUTPUT A SOURCE (Table Output Source -A)	MCB	MCB Close

702	DIGITAL OUTPUT A POLARITY	On (1), Off (0)	Energize
703	DIGITAL OUTPUT B (Table Output Source -A)	GCB	GCB Close
704	DIGITAL OUTPUT B POLARITY	On (1), Off (0)	Energize
705	DIGITAL OUTPUT C (Table Output Source -A)	BUZZER	BUZZER
706	DIGITAL OUTPUT C POLARITY	On (1), Off (0)	Energize
707	DIGITAL OUTPUT D SOURCE (Table Output Source -A)	OVER RPM	Choke
708	DIGITAL OUTPUT D POLARITY	On (1), Off (0)	Energize
709	DIGITAL OUTPUT E SOURCE (Table Output Source -A)	FAIL TO START	FAIL TO START
710	DIGITAL OUTPUT E POLARITY	On (1), Off (0)	Energize
711	DIGITAL OUTPUT F SOURCE (Table Output Source -A)	START	START
712	DIGITAL OUTPUT F POLARITY	On (1), Off (0)	Energize
713	DIGITAL OUTPUT G SOURCE (Table Output Source -A)	ENERGISE TO STOP	ENERGISE TO STOP
714	DIGITAL OUTPUT G POLARITY	On (1), Off (0)	Energize

Configuration Parameters – (Page 8)

801	LAMP TEST ENABLE	On(1) ,Off (0)	On(1)
802	POWER SAVER MODE ENABLE	On(1) ,Off (0)	Off (0)
803	DISPLAY CONTRAST (%)	85%	85%
804	Mains Display Page	00- 127	127
805	RS485 COMM EN	On(1) ,Off (0)	Off (0)

Configuration Parameters – Maintenance (Page 9)

INDEX	SETTABLE PARAMETER	RANGE	DEFAULT
901	OIL MAINTENANCE ENABLE	On(1) ,Off (0)	On (1)
902	OIL SERVICE DUE ACTION	0-3	2
903	OIL MAINTENANCE ALARM HOURS	0-9999h	1000
904	ALARM DUE DATE	1-31	1
905	ALARM DUE MONTH	Jan – Dec	
906	ALARM DUE YEAR	2015 -2075	2019
907	POWER ON DG MODE	0-2	1
908	BTS BATTERY MONITORING ENABLE	On(1) ,Off (0)	Off (0)
909	LOW BATTERY THRESHOLD	40-60	47
910	LOW BATTERY MONITORING DELAY	0-999	10
911	HIGH BATTERY MONITORING	On(1) ,Off (0)	Off (0)
912	HIGH BATTERY THRESHOLD	40-60	56
913	HIGH BATTERY MONITORING DELAY	0-999	10
914	ENGINE MAX RUN TIME	0-999 min	0
915	ENGINE REST TIME	0-999 min	0

916	MODBUS ID	1-247	1
917	MODBUS BAUD RATE	9600	9600
918	MODBUS PARITY BIT	NONE	NONE
919	CT POSITION	CT ON LOAD (0) CT ON DG(1)	Off (0)
920	ROTARY SWITCH ENABLE	On(1) ,Off (0)	Off (0)

Configuration Parameters – Maintenance (Page 10)

INDEX	SETTABLE PARAMETER	RANGE	DEFAULT
1001	Enable Scheduler	On (1), Off (0)	Off (0)
1002	Schedule Run Load	On(1) ,Off (0)	On(0)
1003	Scheduler Period	Week (0) , Month (1)	Week
1004	Scheduler 1 Start Time	0	10:00
1005	Scheduler 1 Start Day	1-7	Monday
1006	Scheduler 1 Start Week	1-4 , L	1
1007	Scheduler 1 Stop Time	0	14:00
1008	Scheduler 2 Start Time	0	10:00
1009	Scheduler 2 Start Day	1-7	Monday
1010	Scheduler 2 Start Week	1-4 , L	1
1011	Scheduler 2 Stop Time	0	14:00
1012	Scheduler 3 Start Time	0	10:00
1013	Scheduler 3 Start Day	1-7	Monday
1014	Scheduler 3 Start Week	1-4 , L	1
1015	Scheduler 3 Stop Time	0	14:00
1016	Scheduler 4 Start Time	0	10:00
1017	Scheduler 4 Start Day	1-7	Monday
1018	Scheduler 4 Start Week	1-4 , L	1
1019	Scheduler 4 Stop Time	0	14:00
1020	Scheduler 5 Start Time	0	10:00
1021	Scheduler 5 Start Day	1-7	Monday
1022	Scheduler 5 Start Week	1-4 , L	1
1023	Scheduler 5 Stop Time	0	14:00

1024	Scheduler 6 Start Time	0	10:00
1025	Scheduler 6 Start Day	1-7	Monday
1026	Scheduler 6 Start Week	1-4 , L	1
1027	Scheduler 6 Stop Time	0	14:00
1028	Scheduler 7 Start Time	0	10:00
1029	Scheduler 7 Start Day	1-7	Monday
1030	Scheduler 7 Start Week	1-4 , L	1
1031	Scheduler 7 Stop Time	0	14:00
1032	Scheduler 8 Start Time	0	10:00
1033	Scheduler 8 Start Day	1-7	Monday
1034	Scheduler 8 Start Week	1-4 , L	1
1035	Scheduler 8 Stop Time	0	14:00
1036	RTC DATE DD:MM:YY		
1037	RTC TIME HH:MM:SS		
1038	RTC DAY	MONDAY to SUNDAY	
1039	SERVICE HR CLEAR	YES/NO	YES

AC SYSTEM

<i>AC SYSTEM</i>	
Index	Type
0	3-Phase DG, 3-Phase Mains
1	1- Phase DG , 1-Phase Mains
2	3-Phase DG, 1-Phase Mains
3	1-Phase DG, 3-Phase Mains

DIGITAL OUTPUT POLARITY

<i>OUTPUT POLARITY</i>	
Index	Polarity
0	De-Energies
1	Energies

DIGITAL INPUT POLARITY

<i>DIGITAL INPUT POLARITY</i>	
Index	Polarity
0	Close to Activate
1	Open to Activate

ACTION

<i>ACTION</i>	
Index	Action
0	Electrical Trip
1	Shutdown
2	Alarm
3	NONE

ACTIVATION

<i>ACTION</i>	
Index	Activation
0	Never
1	From Engine Start
2	From Monitoring
3	Always

<i>INPUT SOURCES - A</i>	
0	LLOP
1	HET
2	LFL
3	HFL
4	RWL
5	CANOPY TEMPERATURE
6	EMERGENCY
7	Fire and Smoke
8	Door Open
9	Remote Mode
10	GCB Latch
11	MCB Latch
12	Simulate Start Key
13	Simulate Stop Key
14	Simulate Auto Key
15	Simulate Mains
16	Close Mains & Open Genset
17	Close Genset & Open Mains
18	Lamp Test
19	Alarm Reset
20	V Belt Fail
21	Mains Charge fail
22	BTS Temp High









Drawing approval subject to valid vendor registration

0	Energise to Start
1	Crank Relay
2	Energise To Stop
3	MCB Open
4	GCB Open
5	MCB Close
6	GCB Close
7	Buzzer Relay
8	Choke Relay
9	Battery Over Voltage Warning
10	Battery Under Voltage Warning
11	Combined Electrical Trip
12	Combined Shutdown
13	Emergency Stop
14	Fail to Start
15	Fail to Stop
16	KW Overload
17	Over Load Current
18	Common Alarm
19	Digital Input A
20	Digital Input B
21	Digital Input C
22	Digital Input D
23	Digital Input E
24	Digital Input F
25	Digital Input G
26	Digital Input H
27	Digital Input I
28	Digital Input J
29	Digital Input K
30	Speed Overshoot
31	DG Under Frequency Shutdown
32	DG Over Frequency shutdown
33	DG Under Speed
34	DG Over Speed
35	Water Temperature Open Circuit
36	Oil Pressure Open Circuit
37	Fuel Open Circuit
38	Water Temperature Shutdown
39	Oil Pressure Shutdown
40	Fuel Level Shutdown
41	Combined Eb Fail
42	Mains Over Frequency
43	Mains Under Frequency
44	Mains Over Voltage
45	Mains Under Voltage
46	Charging Alternator Shutdown
47	Charging Alternator Warning
48	DG Under Voltage
49	DG Over Voltage
50	Auto Mode
51	Manual Mode
52	Stop Mode
53	BTS Mode
54	HI/LO Frequency Shutdown
55	Smoke Limiting

INSTRUMENTATION ICONS





Drawing approval subject to valid vendor registration

When viewing instrumentation pages, an icon is displayed in the **Inst. Icon** section to indicate what section is currently being displayed.

Icon	Details
	The default home page which displays generator voltage and mains voltage
	Generator voltage and frequency instrumentation screen
	Mains voltage and frequency instrumentation screen
	Load power instrumentation screen
	Engine speed instrumentation screen
	Battery voltage instrumentation screen
	Oil pressure instrumentation screen
	Coolant temperature instrumentation screen
	Current time held in the unit

MODE ICON

An icon is displayed in the **Mode Icon** section to indicate the mode the controller is currently in.

Icon	Details
	Auto Mode.
	Manual Mode
	Appears when the unit is in the front panel editor.
	Remote Mode

LOAD SWITCHING ICON

An icon is displayed in the **Load Switching Icon** section to indicate the status of the Controller.

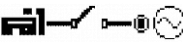
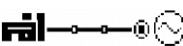
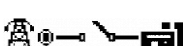
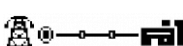





Icon	Details
	The generator breaker is open.
	The generator breaker is closed.
	The mains breaker is open.
	The mains breaker is closed.

Drawing approval subject to valid vendor registration

WARNING ALARM ICONS



Warnings are **non-critical alarm conditions** and do not affect the operation of the generator system, they serve to draw the operators attention to an undesirable condition.

By default, warning alarms are self-resetting when the fault condition is removed.

Icon	Fault	Description
	Low Fuel Level	The level detected by the fuel level sensor is below the low fuel level pre-set pre-alarm setting.
	Battery Under Voltage	The DC supply has fallen below or risen above the low volts pre-set pre-alarm setting.
	Battery Over Voltage	The DC supply has risen above the high volts pre-set pre-alarm setting.
	Generator Under Voltage	The generator output voltage has fallen below the pre-set pre-alarm setting after the Safety On timer has expired.
	Generator Over Voltage	The generator output voltage has risen above the pre-set pre-alarm setting.
	Generator Under Frequency	The generator output frequency has fallen below the pre-set pre- alarm setting after the Safety On timer has expired.
	Generator Over Frequency	The generator output frequency has risen above the pre-set pre- alarm setting.









ELECTRICAL TRIP ALARM ICONS



Electrical trips are latching and stop the Generator but in a controlled manner. On initiation of the electrical trip condition the module de-energizes the '**Genset Contactor Output**' to remove the load from the generator. Once this has occurred the module starts the Cooling timer and allows the engine to cool off-load before shutting down the engine.

Icon	Fault	Description
	Over Current	The measured current has risen above the configured trip level for a configured duration.
	kW Overload	The measured kW has risen above the configured trip level for a configured duration.

SHUTDOWN ALARM ICONS

Shutdown alarms are latching and immediately stop the Generator. On initiation of the shutdown Condition the module de-energizes the '**Genset Contactor Output**' to remove, the load from the generator. Once this has occurred, the module shut down the generator immediately.

Icon	Fault	Description
	Low Oil Pressure	The module detects that the engine oil pressure has fallen below the low oil pressure pre-alarm setting level after the Safety On timer has expired.
	Engine High Temperature	The module detects that the engine coolant temperature has exceeded the high engine temperature pre-alarm setting level after the Safety On timer has expired.
	Under Speed	The engine speed has fallen below the under speed pre alarm setting
	Over Speed	The engine speed has risen above the over speed pre alarm setting
	Charge Failure	The auxiliary charge alternator voltage is low as measured from the W/L terminal.
	Low Fuel Level	The level detected by the fuel level sensor is below the low fuel level pre-set alarm setting.
	Generator Under Voltage	The generator output voltage has fallen below the pre-set alarm setting. After the Safety On timer has expired.
	Generator Over Voltage	The generator output voltage has risen above the pre-set alarm setting.

Icon	Fault	Description
	Generator Under Frequency	The generator output frequency has fallen below the pre-set alarm setting after the Safety On timer has expired.
	Generator Over Frequency	The generator output frequency has risen above the pre-set alarm setting.

USB CONNECTION

The USB port is provided to give a simple means of connection between a PC and the controller. Additionally, the various operating parameters (such as output volts, oil pressure, etc.) of the remote generator are available to be viewed or changed.

To connect a module to a PC by USB, the following items are required:

- Configuration PC Software



- USB cable Type A OR Type B.
(This is the same cable as often used between a PC
And a USB printer)

Drawing approval subject to valid vendor registration

DO'S AND DON'T

- Before connecting any wire to the back terminal please ensure that wire must be inserted at proper terminal.
- after connecting all the wire to the back connector, once again match all the wires with the back terminal sticker.
- don't miss match any wire in the back green terminal.
- For servicing purpose take out the green female connector very carefully by entering uniform pressure on the connector from all sides.
- Check all mechanical parts are fitted correctly and that all electrical connections (including earths) are sound.
- The unit DC supply is fused and connected to the battery and that it is of the correct polarity.

Dimension and Mounting

-

Dimension - 138.50mm x 113mm X 40mm

Panel Cut Out - 118mm x 92mm

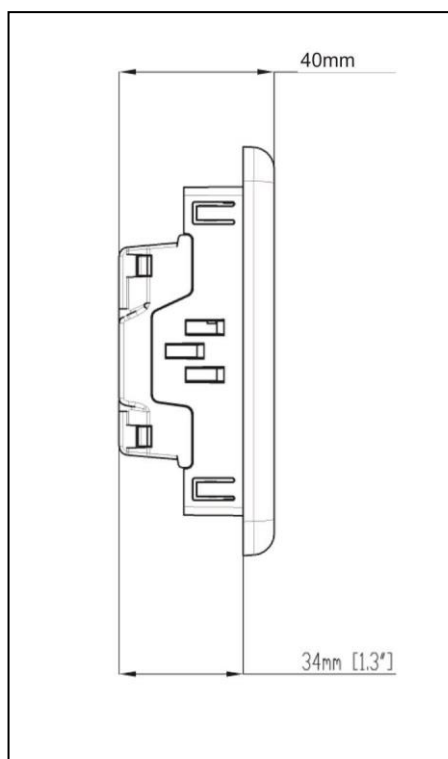

Drawing approval subject to valid vendor registration

GENERAL CHARACTERISTICS

Rating /Phase /Class	3X230V , 50 Hz ,1Ph/3Ph
Minimum Supply Voltage	8V
Maximum Supply Voltage	32V
AC Current Input	-/5A 50/60Hz,1-3Ph
Display Type	Graphical LCD display
Accuracy	Class 1.0
Resolution	1V
Frequency Range	45 Hz to 55 Hz

Terminal Description -

PIN NO.	DESCRIPTION	PIN NO.	DESCRIPTION
1	DC Supply Input (-Ve)	26	Generator L2 (V) Voltage Monitoring
2	DC Supply Input (+Ve)	27	Generator L3 (W) Voltage Monitoring
3	Digital Output A	28	Generator Neutral (N) Input
4	Digital Output B	29	Mains L1 (R) Voltage Monitoring
5	Charge Alt. / Excite	30	Mains L2 (S) Voltage Monitoring
6	Digital Output C	31	Mains L3 (T) Voltage Monitoring
7	Digital Output D	32	Mains Neutral (N) Input
8	Digital Output E	33	R-CT
9	Crank	34	Y-CT
10	Solenoid	35	B-CT
11	BLANK	36	CT Common
12	Digital Input A	37	FAN CT IN
13	Digital Input B	38	FAN CT OUT
14	Digital Input C	39	BTS (-)
15	Digital Input D	40	Blank
16	Digital Input E	41	BTS(+)
17	Digital Input F	42	RS-485 A
18	Digital Input G	43	RS-485 B
19	Digital Input H	44	Blank
20	Digital Input I	45	Blank
21	Digital Input J	46	Emergency
22	Auto / Manual	47	LFL_S
23	CAN L	48	HET_S
24	CAN H	49	LLOP_S
25	Generator L1 (U) Voltage Monitoring		

WIRING DIAGRAM FOR USING CONTROLLER IN MANUAL MODE

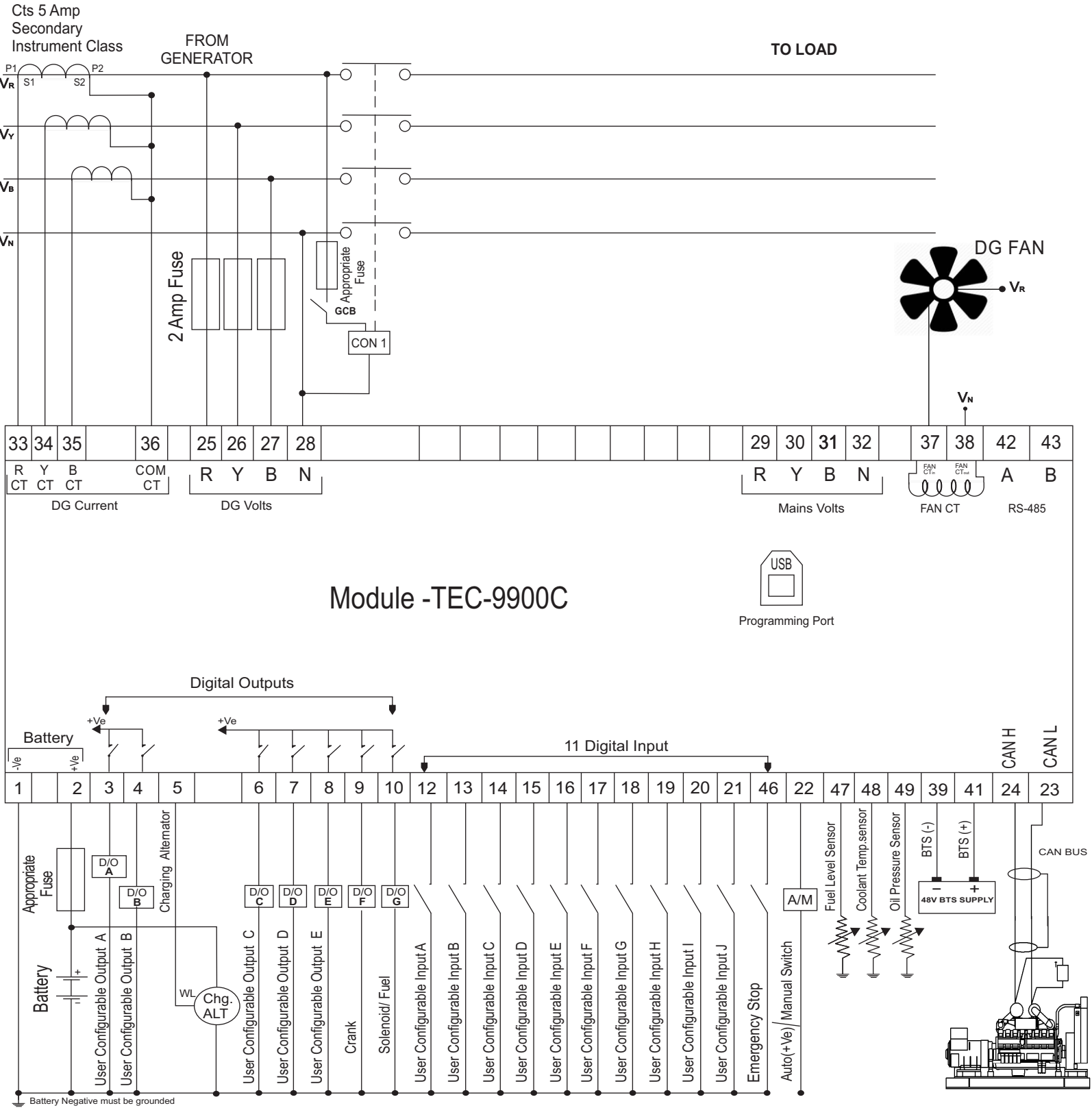

Note 1 -These ground Connections must be on the Engine block ,and must be to the Sensor Bodies.

Note 2 -It is recommended that the Generator and Mains Switching devices are mechanically and Electrically Interlocked.

DIMENSIONS

138.50mm X 113mm X 40mm

PANEL CUT OUT

118mm X 92mm

WIRING DIAGRAM FOR USING CONTROLLER IN AMF MODE

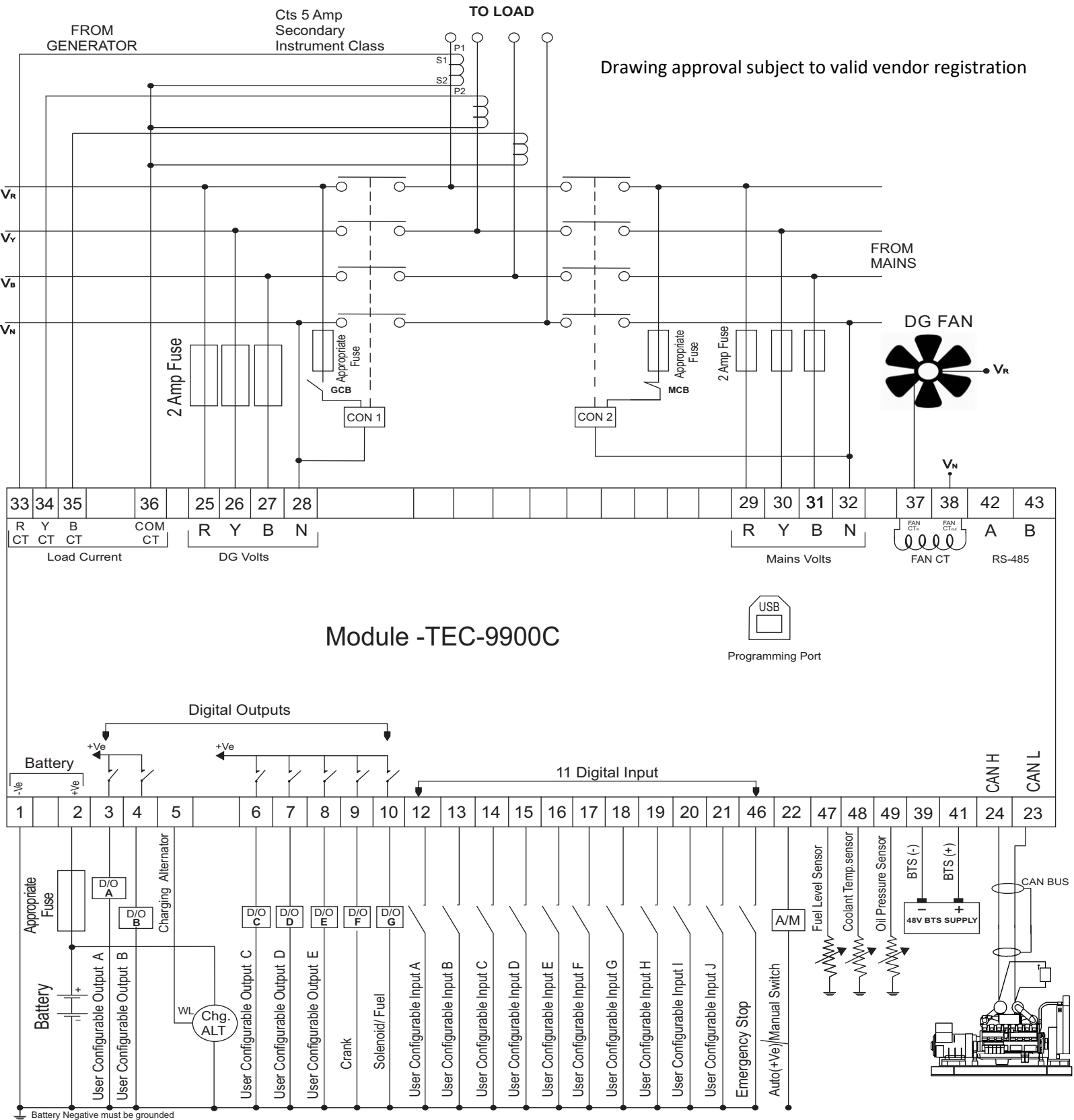

Drawing approval subject to valid vendor registration

Note 1 -These ground Connections must be on the Engine block ,and must be to the Sensor Bodies.

Note 2 -It is recommended that the Generator and Mains Switching devices are mechanically and Electrically Interlocked.

DIMENSIONS

138.50mm X 113mm X 40mm

PANEL CUT OUT

118mm X 92mm

Monitoring Mode

In monitoring mode the screen will scroll automatically after a predefined time or one can use the "Navigation UP/DOWN Keys" to scroll/browse the screens.

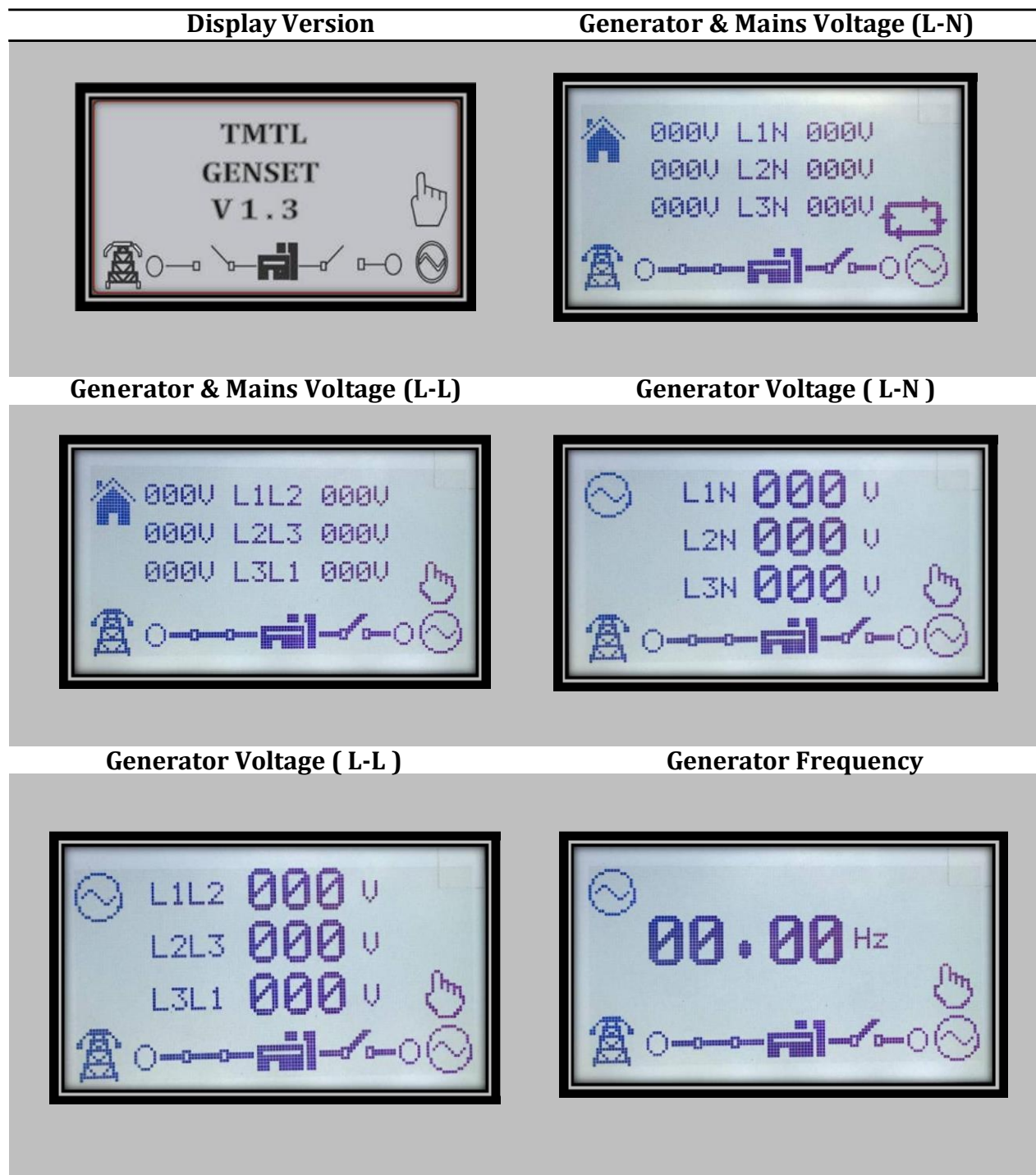

Mains Voltage (L-N)



Mains Voltage (L-L)



Mains Frequency



Load Current



Active Power



Apparent Power



Power Factor



Combined Active Power, Apparent Power & Avg. Power Factor



DG kWh & Eb kWh



Battery and BTS Voltage



Charging Alternator



Oil Pressure



IF Conventional Selected then "Temp.

IF CAN Selected then "Temperature"



Fuel Level



DG Run Hour



Mains Run Hour



Service Hour

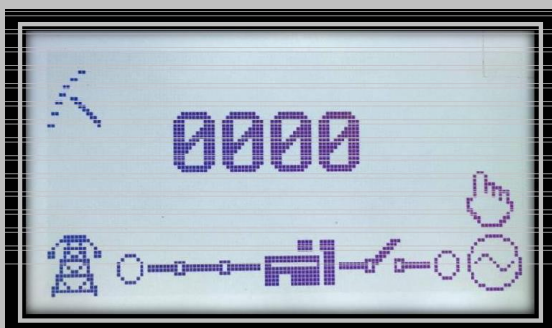
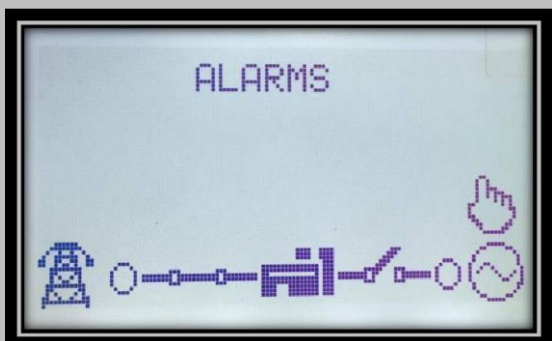

Drawing approval subject to valid vendor registration

Engine Speed**Communication ID****Alarm****Status****Real Time Clock**

Enertrak

IT-3, EPIP RIICO Industrial Area Sitapura, Jaipur (Raj.) -302022

Customer Support: - Email - raj.enertrak@gmail.com

Mobile No. - 8233000062

OPERATOR MANUAL

GENSET ENGINE 322 ES/323 ES (15/20 KVA)





Welcome to the TMTL family

Dear Customer,

We are pleased to present our TMTL ENGINES operator manual and take this opportunity to thank you for purchasing our Genset engine. TMTL engines are one of the world's most economical and trusted engines.

TMTL group is a significant player in the Indian Automobile Industry. The group's products are brought to the customers through its large network of dealers spread across the country. TMTL is into manufacturing state-of-art air cooled & water cooled diesel engines known for their performance in terms of high reliability, high fuel economy and low maintenance cost. Every TMTL engine passes through a series of quality tests before leaving the factory to ensure that you get satisfactory performance from your engine.

This manual will provide relevant information about the handling and maintenance of the engine. All the necessary procedures regarding the installation, normal use & maintenance are stated in this manual. Adherence to instructions mentioned in this manual will ensure proper functioning of the engine. Periodic maintenance at recommended time intervals is of utmost importance for its economical performance and long life. This will save you the cost of expensive repairs. Therefore, it is advised to carefully read this manual & follow the instructions stated in it. All repairing activities should be done only by trained mechanics from our authorized service dealers.

ALWAYS USE GENUINE SPARE PARTS THAT ARE SOURCED FROM OUR AUTHORIZED DEALERS.

Please do not forget to mention the engine serial number when making enquiries or ordering spare parts.

The specifications mentioned in the manual are subject to change without notice as a result of continuous improvement. For any other information or assistance, please contact us at the following address.

TAFE MOTORS AND TRACTORS LIMITED

(A wholly owned subsidiary of TAFE )
ITARANA ROAD, ALWAR-301 001 (RAJ.) INDIA
Ph. : 0144-2332968/969, 2332781/782
Fax : 0144-2333103

INDEX	
DESCRIPTION	PAGE NO.
1. Engine Specification	7
2. General Safety Precautions	8
3. Engine Storage for a Long Period	9
4. Important Checks	10
5. First 50 hours of Engine Running	11
6. Installation Guidelines	12
7. Exhaust System	17
9. Air Intake System	18
10. Dry type Air Cleaner	18
11. Air Cleaner Servicing and Maintenance	19
12. Fuel System	21
13. Fuel Filter Assembly	21
14. Bleeding of Fuel System	23
16. Lubrication System	24
17. Oil Pressure Checking & Adjustment	26
18. LLOP Connection & Checking	26
19. Tappet Checking & Adjustment	28
20. Checking & Adjustment of V-Belt Tension	28
21. Engine Temperature Safety & Solenoid Assembly	29
22. Battery Maintenance	30
23. Fault Diagnosis	31
24. General Faults & Diagnosis	32
25. Periodic Engine Maintenance Schedule for 500 Hrs	33
26. Periodic Service Schedule Activities for 500 hrs	34
27. Periodic Engine Maintenance Schedule for 250 Hrs	35
28. Periodic Engine Maintenance Schedule for 250 hrs	36
29. Warranty Policy	37
30. Address of Regional Offices	40

ENGINE SPECIFICATION		
Model	322 ES	323 ES
1. Application	Genset 15 kVA	Genset 20 kVA
2. Type	Four stroke diesel engine	Four stroke diesel engine
3. Type of cooling	Air cooled	Air cooled
4. Aspiration	Naturally aspirated	Naturally aspirated
5. No. of cylinders	Two	Two
6. Bore (mm)	100	100
7. Stroke (mm)	125	125
8. Piston displacement (cc)	1963	1963
9. Compression ratio	17±0.5 : 1	17±0.5 : 1
10. Governing type	Class A1	Class A
11. Injection type	Direct injection into piston cavity	Direct injection into piston cavity
12. Injector opening pressure	240 - 248 bar	240 - 248 bar
13. Rated power KW (HP)	17.5 (24)	18.9 (25.7)
14. Rated RPM	1500 R.P.M.	1500 R.P.M.
15. Maximum no load RPM	1565 R.P.M.	1565 R.P.M.
16. Minimum Idle RPM	1200 (± 5) R.P.M.	700 (± 50) R.P.M.
17. Firing order	2 - 1	1 - 2
18. Direction of rotation	Clockwise as view from crank pulley side	Clockwise as view from crank pulley side
19. Air cleaner	Dry element type	Dry element type
20. Tappet clearance (Inlet/Exhaust)	0.10/0.10 mm	0.15/0.15 mm
21. Fuel filter element	Primary & Secondary both are common	Primary & Secondary both are common
22. V-Belt size	Cogged Belt, AVX 13 X 1185	Cogged Belt AVX 13 X 1185
23. Battery	12 V, 88 AH	12 V, 88 AH
24. Total oil capacity including filter	8.0 ltr.	8.0 ltr.
25. Oil filter element	Cartridge type/single type	Spinon type
26. Engine dry weight (kg.)	330	340
27. External dimensions (L x W x H)	705 x 765 x 970 mm	695 x 754 x 965 mm

GENERAL SAFETY PRECAUTIONS

" ONLY USE EICHER GENUINE SPARES AND ENGINE OIL "

“Eicher engines are available in different models that are designed for specific applications. Hence it is advised to select the engine model accordingly”

To obtain best performance and long life from the engine, It must be ensured that periodic maintenance activities are done at recommended intervals.

If the engine is being used in excessively dusty environment/other adverse conditions, frequency of certain maintenance activities intervals may vary accordingly.

- Do not allow unauthorized personnel to attend the engine.
- Do not operate the engine if engine safeties are not working properly.
- Do not try to change the configuration or specifications of the engine.
- Do not adjust engine settings while it is in running condition.
- Do not touch th engine while it is hot.
- Do not clean or add lubricating oil to the engine while it is in running condition.
- Do not fill fuel in the fuel tank while engine is in running condition.
- Do not idle the engine for excessively long periods as it can damage engine components.
- Do not allow sparks or fire near the battery (specially when the batteries are being charged) as the gases released from the electrolyte are highly inflammable.
- Do not operate the engine at a location where it can cause concentration of toxic emissions.
- Always disconnect battery terminals before any kind of electrical repair on the engine.
- Always ensure that the engine is operated only through the control panel.
- Always keep the engine dry, clean oil/fuel spills and dust etc.
- Diesel/lubricating oil/coolant may cause irritation on your skin, hence use hand gloves or medicated jelly/cream to protect your hands.
- Seek medical assistance immediately incase of exposure of skin to high pressure fuel.
- Stay away from battery fluid as it is dangerous for the skin & eyes.
- Dispose off the used lubricating oil & filters appropriately to keep the environment clean.

ENGINE STORAGE

Engine Preservation Procedure for Short Term Storage:

1. Store the engine in a dry and well covered area.
2. Clean the engine thoroughly before storage.
3. Disconnect battery terminals.
4. Start and run the engine for a few minute atleast once in a week.

Engine Preservation Procedure for Long Term Storage:

1. Run the engine at 'No' load for 5 min to warm up the engine.
2. Drain out the lubricating oil from the sump and fill it with a suitable preservative oil (as mentioned in table 1.1)
3. Run the engine at 'No' Load for 3-4 min for circulaton of preservative oil throughout the lubricating system/ engine.
4. Stop the engine and disconnect the fuel supply to fuel pump.
5. Drain fuel from fuel tank.
6. Drain preservative oil from sump.
7. Seal air cleaner inlet, intake pipe, breather hose outlet, exhaust pipe, fuel tank vent hole & other openings with waterproof tape.
8. Apply rust preventing solution (refer to table 1.1) on all unpainted external metal parts.
9. Apply waterproof tape on the dipstick for sealing.
10. Loosen V-belt by reducing the belt tension.
11. Wrap the engine in Polyethene, apply a tag on it to show that it has been treated with preservatives (date of treatment & validity) and store it in a dry area.
12. Inspect the engine for rust or corrosion on a regular basis. Take corrective action if required.
13. All electrical connectors should be closed by protection cap.

Note: If the engine is to be stored for more than 6 months, repeat the above mentioned procedure after every 6 month

Manufacturer	Engine Lubrication oil & Fuel system	Unpainted ferrous components
Indian Oil Corporation	Servo Preserve 30	Servo RP 125
Hindustan Petroleum	Autoprun T 120	Rustop274
Bharat Petroleum	Bharat Preserve Oil 30	Bharat Rustrol 152
Veedol Tide Water oil Co.	Veedol 30/40	Veedol ruspro IT

Table1.1: Recommended preservatives for long term storage of engine

Engine De-Preservation Procedure after Long term storage:

1. Clean the engine thoroughly by using an air jet to remove dust from all external parts of the engine.
2. Remove all sealing tapes from various openings.
3. Remove rust preventive coating from all unpainted metal surfaces using NC thinner.
4. Fill sump with recommended grade of lubricating oil upto the 'top' mark of the dipstick.
5. Change lube oil filter.
6. Re-adjust V-belt tension.
7. Clean the cooling system.
8. Change fuel filter elements.
9. Check the injectors for correct spray characteristics and pressure setting.
10. Reconnect a fully charged battery to the engine.
11. Check the complete electrical charging circuit.
12. Crank the engine until the oil pressure builds up.
13. Start the engine and ensure that the recommended oil pressure is attained.

IMPORTANT CHECKS FOR OPERATING THE ENGINE

Checks before Starting the Engine:

- Check oil level in the sump, ensure oil level should not be below the lower dipstick mark.
- Check diesel level in the fuel tank. If required, fill sufficient fuel in the fuel tank.
- Check the belt condition & its tension. If loose, adjust accordingly as per specified limit.
- Ensure engine stop solenoid is at normal position.
- Start the engine and run without load.
- Check for any lubricating oil or fuel leakages. If observed, rectify the same.
- Check nuts & bolts before starting the engine. Never tighten the bolts or nuts while the engine is in running condition.

Take care of the following:

- Oil level should be checked after stopping the engine (wait for ½ hr to allow the oil to drop back into the sump).
- It is better to re-fill the fuel tank after using the engine as it helps in avoiding condensation of moisture inside the fuel tank.

Engine Starting Procedure:

- Place the key in starting switch and turn it clockwise to its first position 'ON'.
- To start the engine, turn the key further in clockwise direction. After the engine starts, release pressure from the key. The key will come back to its ON position.

CAUTION

Do not crank the engine for more than three seconds. If it does not start in the 1st attempt, wait for 20 seconds for the second attempt.

- Check the functioning of all the instrument gauges present in the control panel.
- Observe engine sound and noise. If any abnormality is observed, stop the engine immediately and contact the nearest authorized service dealer.

Adjustment of engine RPM

1. Engine rpm should be adjusted through the hand accelerator only. No other component needs to be adjusted.

▲ CAUTION

2. The minimum and maximum RPM are adjusted and the hand accelerator is sealed in the factory. These seals are important for the warranty. In case the seals are broken, the engine shall not be entitled for warranty. For any adjustment, please contact the nearest authorized service dealer.
3. Changing the minimum and maximum RPM affects the engine performance. Incorrect adjustments can damage the engine parts or cause severe accidents.

Arrangement for Stopping the Engine

1. Remove the entire load from the engine before stopping it.
2. Stop the engine only through the solenoid (Stop switch) .
3. After stopping the engine turn the starting key to 'OFF' position and take out the key from the switch.

If the engine remains unused for few days, it is better to start the engine at least once in a week for 10-20 minutes for battery charging . It will improve battery life.

IMPORTANCE OF FIRST 50 HOURS OF ENGINE RUNNING

The "Running in period" of a new engine is extremely important for the engine's life (specially the first 50 hours). Therefore, the following instructions should be followed carefully during the first 50 hours.

1. Start the engine and run it at 'No' load for 3 to 5 minutes to warm up the engine oil.
2. Observe & monitor the gauges & indicators of the control panel.
3. Gradually apply load on the DG (60 to 80% of the specified full load).
4. Avoid any overloading on the engine/DG in any circumstances.
5. After first 50 hrs of engine, strictly follow the service schedule as specified by the manufacturer.
6. In case of any abnormal noise, please stop the engine immediately and contact the nearest authorized service dealer.

Most Important

Prolonged operation at light loads during the early life of the engine can cause lubricating oil to enter into the exhaust system. A Minimum 60% load should be applied after 03 to 05 minutes of engine running. It will be better for the engine if the load is applied as soon as possible i.e. after the oil warms up.

INSTALLATION GUIDELINES

IMPORTANCE OF PROPER INSTALLATION

A good installation results in:

- Reduced vibration in DG set/reduced transmission of vibrations to the building structure.
- Improved durability and longer life of the Genset.
- Easy serviceability.
- Optimum availability.
- Better fuel economy.
- Better working conditions.
- Improved aesthetics of DG set.
- Better sound absorption as per CPCB Norms.
- Protection of environment.

Prerequisite of DG Set installation:

- Site selection
- Room Layout – DG Set Installed in room.
- Ventilation
- Foundation
- Exhaust System
- Electrical (AC/DC) System
- Earthing

SITE SELECTION

1) DG Set installed in Open

- Acoustic enclosure location should be decided after considering the wind direction & ensuring that there is no obstruction to the fresh air flow. There shouldn't be any restrictions in front of the hot air outlet and on the fresh air suction sides. The generator should be placed such that no wall is located on any side of the DG set (upto a distance of atleast 1 meter).
- Enclosure should be located in a pollution free environment and should not be allowed to come in contact with acidic fumes, cement, dust, stone dust, cotton fibers, furnace, chemicals etc.
- Ensure sufficient working space for major/minor work such as routine maintenance overhauls or component removal/replacement.

- For roof top installations, the genset should be installed on a RCC slab or I-Beams of suitable section which in turn should be supported on the columns & beams of the building structure. In addition to this, roof top installations require further planning and structural design consideration.

2) DG Set is installed in a room

- Ensure minimum 1 to 1.25 meter free space around the DG set. Ensure no obstruction in DG set door opening and fuel tank removal.
- In case of Multiple DG set Installation minimum 1.5 to 2 Meter free space is required between both the DG sets.
- Ensure that the hot gases should not circulate in the DG room. Ensure adequate ventilation by providing exhaust fans of adequate capacity.
- Main gate should allow easy entry & placement of DG set.
- Future expansion should be considered during room design.
- Provision for changeover (Mains to DG set supply & vice versa) should be considered in case of Manual/semi automatic panel.
- Consider proper storage of fuel/lube oil etc. Consider the exhaust gases expulsion outside the DG room.

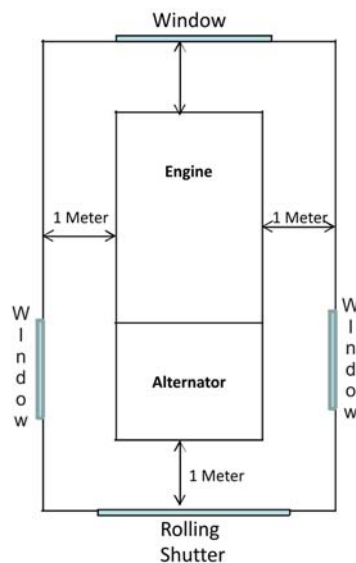

VENTILATION

Room Ventilation:- If DG set is installed in room The DG Set room requires a proper ventilation to remove heat and fumes from the canopy/DG room. Ventilation also provides fresh and clean air for full combustion.

Poor Ventilation leads to:-

- Overheating of the engine and alternator.
- Poor fuel efficiency/DG set performance.
- Temperature rise results into early failure of gasket and sealing rings.
- Early wear of engine parts due to heating up & thinning of oil.

Important : Cross ventilation and free flow of cool, clean and fresh air should take place from alternator end to engine.

- For basement installations, supply of fresh air and forced ventilation through air ducts is required so that the heat is removed through the exhaust fan present outside the DG Set.
- If opening in the back is not possible then window on both sides of Genset at alternator side is required, but, total window cross section should be three times of radiator core.
- Maximum permissible temperature rise above ambient temperature inside the Genset room or acoustic enclosure is 7 Deg. celsius as measured at the air cleaner inlet of the engine.

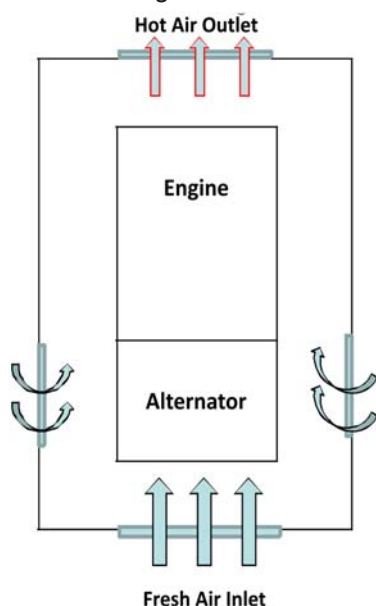

FOUNDATION

Precautions during Installation:

- Do not install the Genset on loose sand or clay.
- Foundation should be designed considering safe bearing capacity of soil.
- The length and width of foundation should be at least 300 mm more than base rail of the canopy length and width respectively.
- Ensure that the concrete is completely set and cured before positioning the Genset.
- It is recommended to have foundation height about 150-200 mm above ground level and an equal depth inside the ground. It helps to maintain cleanliness of Genset.
- Foundation should be evenly flat (diagonally as well as across the length). Ensure that the complete base rail rests on the foundation and no gaps are there between base rail and the foundation.
- For roof top installation ensure that the load of DG set is completely transferred on pillar and beam structure. It is strongly recommended to consult a structural engineer for more details.
- For excellent vibration isolation, anti-skid rubber pads may also be used as per advise from the Genset supplier.

EXHAUST SYSTEM

Need of good exhaust system

- Exhaust system viz. exhaust pipe size, number of bend, and support to exhaust pipe is designed to maintain back pressure within the max. permissible limits.
- Back Pressure in excess of specified limits results into:
 - a. Engine power loss and poor performance.
 - b. Lower fuel economy.
 - c. High exhaust temperatures and related failures.
 - d. Higher blow-by.
 - e. Less durability of the engine due to carburizing inside of engine parts.

Need of a Good Exhaust System

- Ensure safe disposal of burned gases out side of DG room to avoid recirculation inside the room.
- It is recommended to use 'Schedule - A' MS ERW pipes & long sweep bends in the exhaust piping.
- The number of long sweep bends should not be more than four. If more number of bends are required or pipe length is more, please contact OEM/Eicher Engines for piping arrangement and pipe size recommendations.
- Ensure to fit rain cap on silencer pipe to protect the engine from rainy water.
- Use of thimble is must while passing the pipe through concrete wall; The clearance around the pipe in wall is must for free movement and expansion/contraction of piping under temperature variation.
- Ensure that exhaust piping is well supported and load of exhaust pipe should not be on silencer or DG set canopy. Best location of exhaust support is just after exhaust elbow.

ELECTRICAL (AC/DC) SYSTEM

Ensure the following while connecting genset control panel to load side:

- Use power cable of adequate size i.e. of adequate current carrying capacity)
- Terminate power cable at control panel as well as on the load side using Copper lugs (for Copper conductor cables) or Aluminum lugs (for Aluminum conductor cable) of suitable size.
- Always use cable glands while connecting cables to control panel to avoid load on terminals and prevent premature burning of lugs and conductors.
- In Gensets with external AMF Panels, connect control cable from the genset junction box to the panel using suitable control cable with copper lugs for end termination.
- Ensure proper tightening of the cable at terminals. Loose connections leads to heating up of the terminals and cause sparking/burning of cable or terminal.

EARTHING

Earthing Means:

Connection given to the earth by means of a conductor connected to the earth electrode buried in soil is Earthing.

Good earthing Means:

Resistance less than 1 ohm and voltage as measured between neutral to earth pit less than 5 volts AC is known as good earthing.

Qualities o f good earthing:

The qualities of a good earthing system are : It

- Must be of low electrical resistance.
- Must be of good corrosion resistance.
- Must be able to dissipate high fault current repeatedly.
- There should be minimum 1.5 to 2 mtr distance between two earth pits otherwise current may leak between earth pits.

Need of good earthing:

- To save human life from danger of electrical shock or death.
- To provide an alternative path for the fault current to flow so that it will not harm the user.

How earthing works?

- Electric current has the tendency to flow towards low resistance and earth resistance is very low (ZERO) in system so leakage current will flow in earth and save human life.
- Termination of neutral by earth pit makes the neutral at ZERO voltage and saves the precious equipment from current leakage.

Important:

- The generator set and all associated equipment control and switch gear panels must be earthed before the set is put into operation.
- Minimum 4 numbers earth pits are required as per Indian Electricity Rules. Two separate earthing pits for genset/control panel body/alternator body and two separate earthing pits for neutral.

- Copper or GI strip of suitable size should be used for earthing.
- Genset should be earthed at two distinct points through a conductor heavy enough to carry the short circuit current without burning out.

TYPES OF EARTHING

There are various ways of doing Earthing:-

- Pipe earthing
- GI plate earthing
- Cast iron plate earthing
- Copper plate earthing

Example of Standard Pipe & Plate Type Earthing:

1. Earthing Pit : Size 1000 X 1000 X 1800 mm depth.
2. M.S./C.I. Plate : 500 X 500 X 8 mm thick.
3. Electrode Assembly : 40 mm Ø GI/CI perforated pipe duly fitted or welded with base plate and 50X6 mm flat termination taken on top for equipment earthing as shown in drawing.
4. Mixture - I : Homogeneous mixture of black soft soil 0.3 CMT. approx. with our Vx-EHT(RED) complex 25 Kilograms.
5. Mixture - II : Homogeneous mixture of common salt 25 Kgs. + wood charcoal pieces 25 Kgs. + Black soft soil 1 CMT. approx.
6. Crushed rock pieces Gravel Size 50X35 mm 0.1 CMT. approx.
7. Arrangement for earthing lead terminations from equipment body, and connection for main earthing grid.

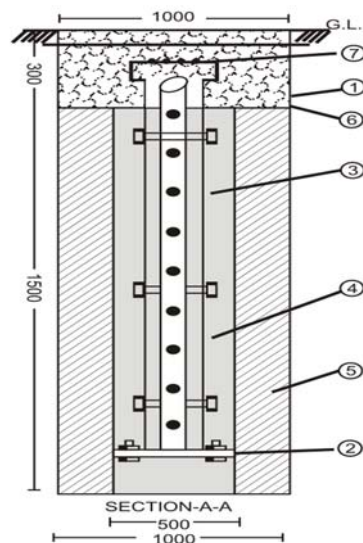

Earthing Conductor for DG Sets from 5 kVA to 125 kVA Rating

DG Set kVA Rating	Earthing Conductor Size
5 / 7.5	10 SWG(3.15 mm) Copper Wire
10	10 SWG(3.15 mm) Copper Wire
15	10 SWG(3.15 mm) Copper Wire
20	8 SWG(4 mm) Copper Wire
25	8 SWG(4 mm) Copper Wire
30	8 SWG(4 mm) Copper Wire
35	8 SWG(4 mm) Copper Wire
40	8 SWG(4 mm) Copper Wire
45	8 SWG(4 mm) Copper Wire
50	8 SWG(4 mm) Copper Wire
62.5	8 SWG(4 mm) Copper Wire
75	8 SWG(4 mm) Copper Wire
82.5	25x3 mm Cu Strip / 25x6 mm GI Strip
100	25x3 mm Cu Strip / 25x6 mm GI Strip
125	25x3 mm Cu Strip / 25x6 mm GI Strip

LIFTING OF DG SET

- Provision for Genset lifting is provided on base rails of the canopy. Unload the genset from base rail by lifting with proper genset lifting tackle i.e. steel rope of suitable capacity and crane so as to ensure no damage to the genset.
- Pass the steel rope through the rope guides provided on the roof.
- Do not lift the genset from the hooks provided at the roof of canopy.

ENGINE LIFTING

GUIDELINES FOR DG CONTROL PANEL CONNECTIONS :

- Use cables of recommended size as mentioned in table below
- Use proper lugs i.e copper lugs (for copper conductor cables) or Aluminium lugs (for aluminium cable) of suitable size.
- Use proper cable glands while connecting cables to control panel.
- Ensure proper tightening of cable at terminal end. Loose connections may lead to heating up/ burning of cables or terminals.

1. Always use the engine lifting hook to lift the engine.
2. Never lift the genset from the engine hook or the alternator hook



Cable Sizes for DG Sets from 5 kVA to 125 kVA Rating

DG Set kVA Rating	Phase	Rated Line Current (Amp)	Line Current with 10% O/L (Amp)	No. of Core	Cable Size ALUMINIUM Armoured Cable		Cable Size COPPER Armoured Cable	
					Area of Conductor (sq. mm)	Current Carrying Capacity of Cable (Amp)	Area of Conductor (sq. mm)	Current Carrying Capacity of Cable (Amp)
5	Single	22	24	2	6	30	4	30
7.5		33	36	2	10	47	6	45
10		44	48	2	16	59	10	60
15		65	72	2	25	78	16	78
20*		87	NA	2	35	99	25	105
20		87	96	2	50	105	25	105
25		109	120	2	50	125	35	125
30		131	144	2	70	150	50	155
35		152	167	2	95	185	70	195
40		174	191	2	120	210	70	195
5	Three	7	8	3.5	2.5	18	2.5	24
7.5		10	11	3.5	2.5	18	2.5	24
10		14	15	3.5	4	23	2.5	24
15		21	23	3.5	6	30	4	30
20*		28	28	3.5	6	30	4	30
20		28	31	3.5	10	40	6	39
25		35	38	3.5	16	51	10	52
30		42	46	3.5	16	51	10	52
35		49	54	3.5	25	70	16	66
40		56	61	3.5	35	86	16	66
45		63	69	3.5	35	86	25	90
50		70	76	3.5	50	105	35	110
62.5		87	96	3.5	50	105	35	110
75		104	115	3.5	70	130	50	135
82.5		115	126	3.5	70	130	50	135
100		139	153	3.5	120	180	70	165
125		174	191	3.5	150	205	120	235

* For Standby Rating

Note: Cable ratings have been arrived at considering spike & motor starting loads that sometimes exceeds the O/L limit of the DG Set.

Drawing approval subject to valid vendor registration

EXHAUST SYSTEM

Installation & use of proper exhaust pipe diameter play a vital role in engine performance as it affects the exhaust gases back pressure. The exhaust back pressure should be as low as possible and should never be more than 60 mm of Hg.

High exhaust back pressure leads to :

- **Lower fuel economy**
- **High exhaust temperature related failures**
- **Poor performance of the engine**
- **Less durability of the engine**

The exhaust back pressure depends on the size of pipes, sharp bends etc. Therefore when the piping arrangements are made, following points should be taken care of:

1. Exhaust pipes should have minimum number of bends & elbows should never be used at bending points.
2. The exhaust gas pipe diameter should be according to the back pressure of gases in the pipe. The pipe diameter also depends on the total length of exhaust pipe.
3. The total length of pipes should be kept as short as possible as excessive length of pipes can increase back pressure on the piston which can reduce engine efficiency.

If number of bends are more than 4 or pipe length is more than 10 meters then please contact nearest authorized dealer for piping arrangement.

4. It is better to use Black M.S.ERW pipes having a minimum diameter of 50 mm (2 Inches).
5. If the required pipe length is more than 3m , then it is advised to increase the pipe diameter by 10 - 15 mm for every 5m of pipe length.
6. Avoid sudden increase in diameter while connecting two pipes. Also, It is better to connect the pipes using flanges & nut-bolts instead of sockets or unions.
7. Use an expansion bellow between the exhaust manifold & exhaust pipe.
8. Provide proper support to exhaust pipes to avoid load on cylinder head exhaust port/exhaust manifold.

9. Exhaust piping inside the generator room should be lagged with aluminium sheet cladding to avoid heat dissipation in the room. Typical thickness of lagging is 50 mm.
10. It is also recommended that the horizontal run of exhaust piping should have a downward slope.
11. The pipe outlet should be bent in such a way that outgoing gases do not enter the generator room & rain water should not enter inside through the pipe opening. Pipe outlet end may be cut at approximately 30 degree angle.
12. In vertically open exhaust pipe outlets, use rain cap to prevent rain water entry.

Operational maintenance checks for exhaust system:

1. Ensure that all connections/clamps & latches are properly tightened.
2. Do not allow dust/oil/water droplets to enter into the the exhaust system as it can damage precision components of the engine.
3. Keep the exhaust piping area neat and clean & free from dust & oil deposits.
4. Carry out all the scheduled activities as stated in the maintenance chart described later on.
5. Care should be taken to ensure that no carbon particles emitted due to exhaust leakage enters and deposits on alternator windings and open connections

AIR INTAKE SYSTEM

It's most important for the combustion process that clean air is sucked through the engine inlet manifold. If dust or foreign particles are not filtered out from the air by the air cleaner, the cylinder liner, piston & piston rings will eventually wear out. Hence, the air cleaner should be serviced at recommended intervals or on need basis.

DRY TYPE AIR CLEANER

Dry type air cleaner filter element has a built in cyclone separator which gives a swirling effect to incoming air that separates out heavy dust particles by centrifugal action.

The dust is collected in the end cover from where it can be easily removed. The evacuator valve is located at the bottom & helps in expelling the accumulated dust. This is achieved through opening/closing of evacuator valve outlet due to the airflow fluctuations inside the air cleaner.

“Never clean the air cleaner when engine is in running condition. Clean only when engine is in stop condition.”

Components of air intake system

- Air cleaner - element/housing
- Air cleaner hoses
- Suction pipe
- Vacuum indicator
- Intake manifold & gaskets
- Hose clamps



Air Intake System

Vacuum Indicator: Vacuum indicator (choke indicator) is mounted on the outlet pipe of air cleaner. It indicates excessive air restriction through a dry type air cleaner. The red band is visible from glass window of this indicator. The band gradually rises as the element gets loaded with dirt and pops out when the element gets choked.

When red band pops out, clean or replace the filter element. After cleaning or replacement of filter element, reset the popping band of vacuum indicator by pushing it.



Maintenance of Intake manifold

- Ensure that all nuts/bolts are tightened properly.
- Ensure no damages due to external heating.
- Whenever removed, check for traces of dust & oil.
- Ensure condition & proper fitment of gaskets.

Reasons for dust entry in combustion chamber

- Missing/cracked vacuum indicator
- Torn/porous air cleaner element
- Use of non genuine parts/filter element
- Improper sealing of element in housing
- Bent guides of element
- Bent guides of element
- Missing sealing rings of element

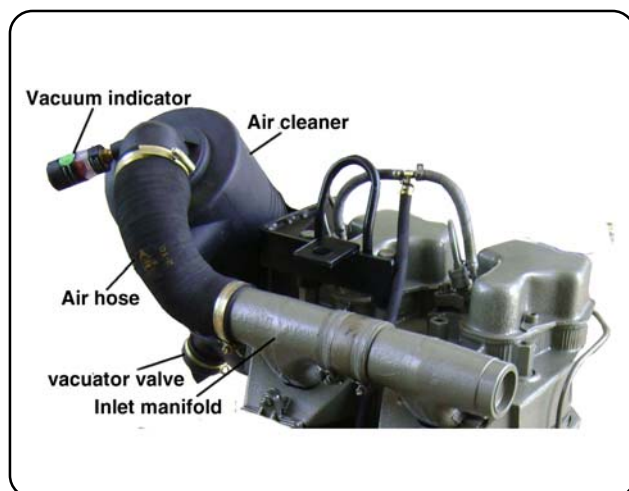

Maintenance of Air Cleaner

Maximum air intake restriction with clean filter is 380mm (15") water column. All engines are provided with suitable vacuum indicator. It indicates the choking of air cleaner element. Air restrictions or choked air cleaner may lead to:

- Incomplete combustion of fuel
- Excessive black smoke
- Low power/loss of power
- Hard starting/failure to start
- Reduced fuel economy
- Excessive lubricating oil consumption
- Carbon deposition in combustion chamber etc.

Servicing and Maintenance

- Never clean "air cleaner" in running condition of engine
- Never run engine with choked air cleaner element
- Never run the engine without air cleaner element.

Air cleaner service procedure:

1. Clean air cleaner element & housing as per recommended hours.
2. If vacuum indicator red band pops up between any two consecutive services, immediately clean the air cleaner element.
3. For cleaning air cleaner element, carefully remove the element and take it out from the housing. Carefully handle the element during cleaning. Do not strike it against the hard surface to loosen out the accumulated contaminants. Tap gently to remove loose dust particles.

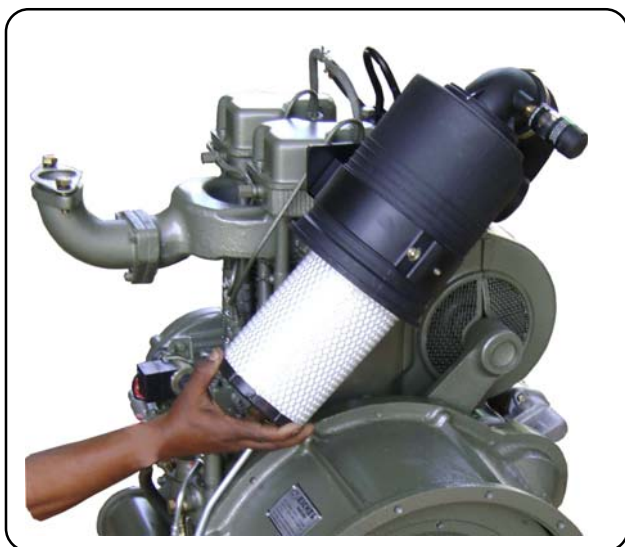

Removal of Air Cleaner Element

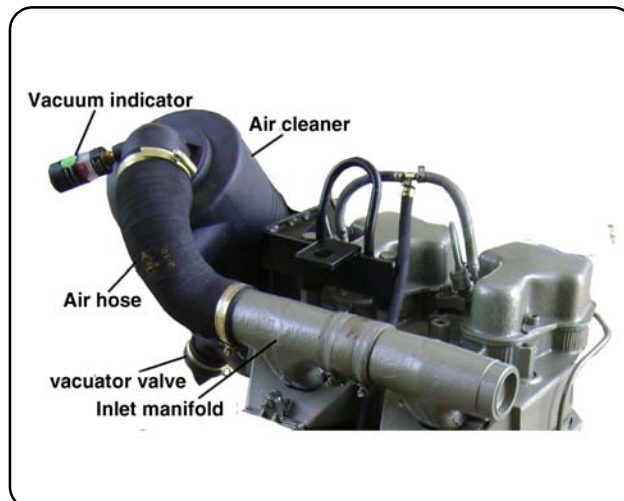

4. Clean the cartridge by blowing air pressure at max.1 bar pressure (14 psi) and blow air from inside to outside (opposite direction of normal air flow).

⚠ WARNING

Higher pressure (>14 psi) could puncture/damage filter element.

5. Never blow direct air jet from outside to inside as the dirt can make tiny holes in the element paper and cause dirt particles to enter & damage the engine.
6. Do not use elements whose folds or seals are damaged.



Cleaning of Air Cleaner element

7. It is better to check the element after cleaning with a light bulb. If small holes or fold torn out are observed, the cartridge should be replaced.



Light Bulb test

8. Wipe the air cleaner housing & its cartridge sealing area by clean cloth .
9. Ensure proper sealing of cartridge into the housing before latching the cover.
10. Do not use latches on the cover to force the filter into air cleaner which could cause damage to housing.

"The filter's choking time depends on user's environmental condition. Normal filter element life is approximate 1200-1500 hours"

CAUTION

Dust holding capacity of the element is reduced by cleaning. Therefore, It is recommended to replace the air cleaner element after every 3 cleanings/ every 1200 to 1500 hours.

"The regular check up and maintenance of the air cleaner is essential to protect dust entry in the air intake pipes. It must be taken care of that rubber hoses have no cuts or damages and its clamps should not be loose".

Operational maintenance checks for air intake system:

1. Periodically check the air cleaner vacuum indicator for choking of air filter element/s. If red band pops up between services, immediately clean the elements as described in earlier sections.
2. Inlet position of the air cleaner should not be disturbed.
3. Check condition of outlet pipe for any bulging/ squeezing.
4. Ensure that all connections/clamps & latches are properly tightened.
5. Don't allow dust/oil/water droplets to enter into the the intake system as it can damage precision components of the engine.
6. Check the turbocharger for any leakage or abnormal sound. Clean the turbo oil drain pipe to prevent clogging of the pipe and for smooth functioning of the equipment.
7. Keep the air cleaner housing area neat and clean & free from dust & oil deposits.
8. Carry out all the scheduled activities as stated in the maintenance chart described later on.

FUEL SYSTEM

The diesel filtration is accomplished by dual filter assembly, before the fuel is supplied to fuel pump & injector. For ensuring proper filtration and avoiding expensive repairs, follow these instructions :-

1. Always use properly filtered high speed diesel.

⚠ WARNING

Do not use cheap / adulterated fuel

2. Do not shake diesel drum while filling fuel in fuel tank as impurities settled at the bottom of the drum may get mixed up with the diesel.
3. To minimize water droplets in fuel tank due to condensation of moisture, it is advisable to fill the fuel tank with diesel after the day's work is over.

"Drum and funnel should be kept absolutely clean and covered up when not in use"

FUEL FEED PUMP

In fuel feed pump, a filter is provided in the sediment bowl to trap coarse particles in diesel. The bowl holding the filter can be removed by unscrewing the knurled nut at its bottom. Clean this filter in every PM service.

Fuel Feed Pump Pre-filter Cleaning

1. Unscrew the clamping nut below the fuel feed pump bowl, swivel out the clip and remove the bowl downward.
2. Take out the pre filter & spring. Rinse the pre-filter fresh diesel.
3. Replace pre filter bowl sealing ring during every cleaning.

"Ensure proper fitment of rubber seal while refitting bowl on feed pump and if seal is damaged replace with new".

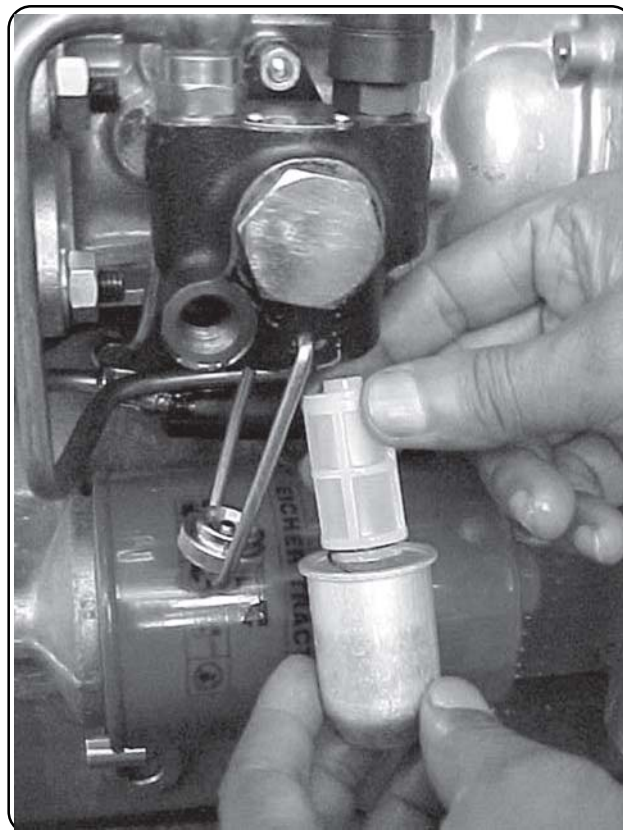

Cleaning of Feed Pump Bowl

FUEL FILTER ASSEMBLY

The diesel filtration is accomplished by a dual filter assembly before the fuel is supplied to the fuel pump & injector. For ensuring proper filtration and avoiding expensive repairs, follow instructions very carefully:-

FUEL FILTER ELEMENT REPLACEMENT

1. Clean fuel filter assembly from outside.

⚠ CAUTION

Do not allow dirt particles to enter in the fuel system.

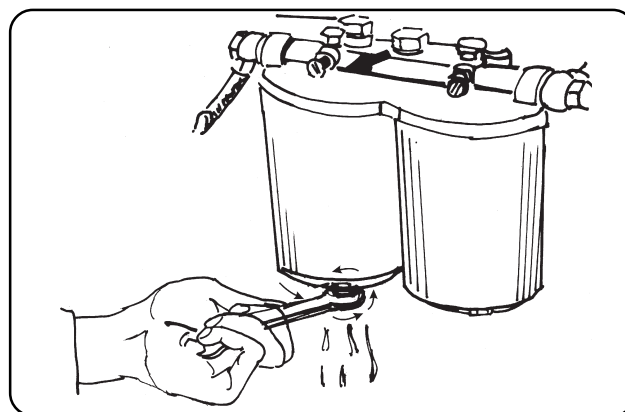

2. If over-head tank is being used for diesel, close the fuel cock before opening the filter bowl.

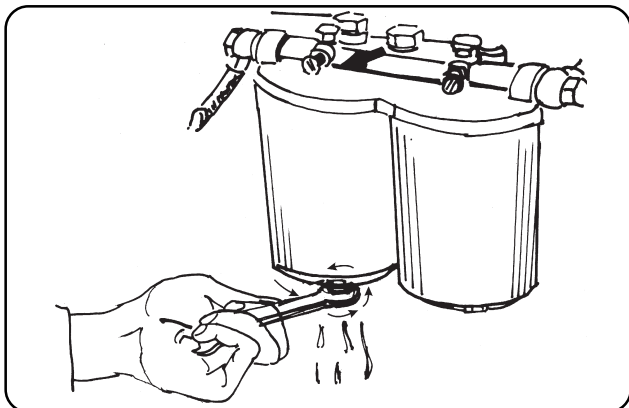

3. A drain screw is provided at the bottom of fuel filter shells that helps to drain out the water. The frequency of water draining depends on environmental conditions (humidity); If humidity is more, drain every 15 days.
4. Drain out diesel from the shells by loosening the bottom drain screws, otherwise dirty diesel may enter in the fuel injection equipment.
5. Unscrew the centre bolt of primary & secondary shells from fuel filter head and take out filter elements from them.

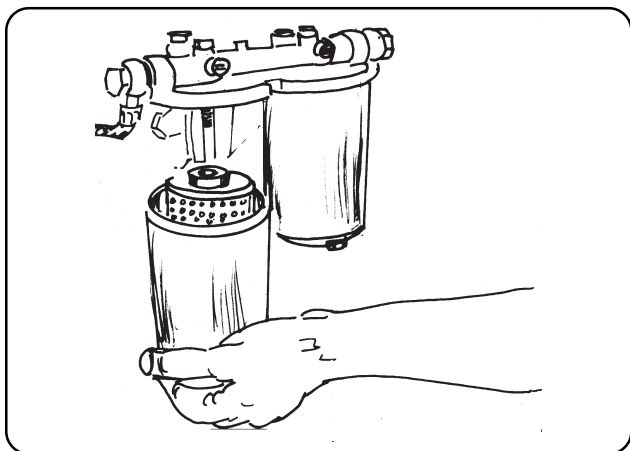

6. Clean filter bowl by kerosene or diesel.
7. Replace new fuel filter element by Genuine Eicher spares at every 500 hours .
8. Also replace rubber seal & sealing washer.

"In Eicher engines, Primary & Secondary filter element are same".

CAUTION

"Never fill-up filter shell with diesel before fitment. Fill using hand primer of feed pump after proper fitment"

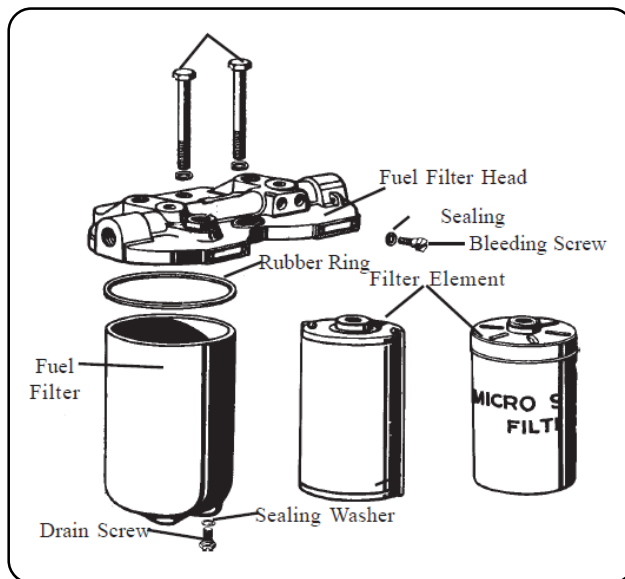

9. Torque centre bolt at 2.5 Kgf. Torque.
10. Ensure no diesel leakage from any joint.

Important

Replacement of fuel filter/s at early hours may also be required incase contaminated/adulterated fuel is used.

"Dispose off old filter elements and diesel by safe and efficient processes for protection of our environment against pollution."

BLEEDING OF FUEL INJECTION SYSTEM

How to bleed the system ?

1. Ensure that there is enough fuel in the fuel tank.
2. Loosen the bleeding screw of primary fuel filter

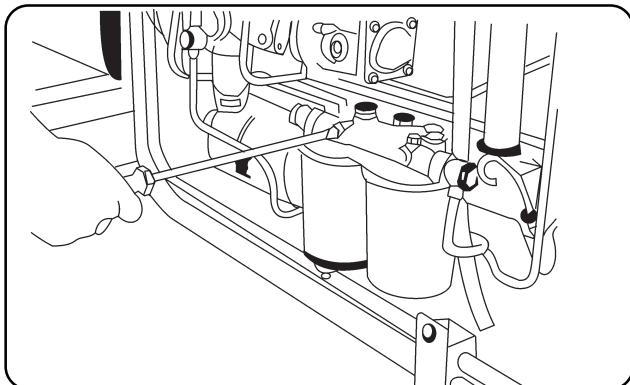

Air Bleeding from Fuel Filter

3. Unscrew priming knob of fuel feed pump, move it up and down till the fuel flows out from air vent screw without air bubbles.
4. Repeat same steps in secondary fuel filter for air bleeding.
5. Tighten the air vent screws after the air bleeding.
6. At last loosen the air vent screw of fuel injection pump & bleed out the air bubbles.

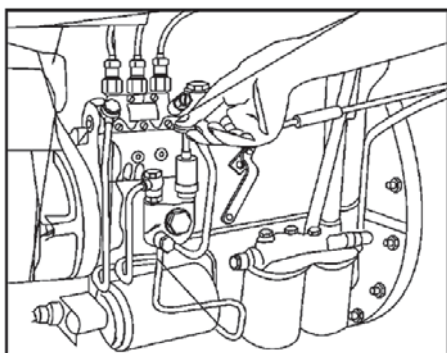
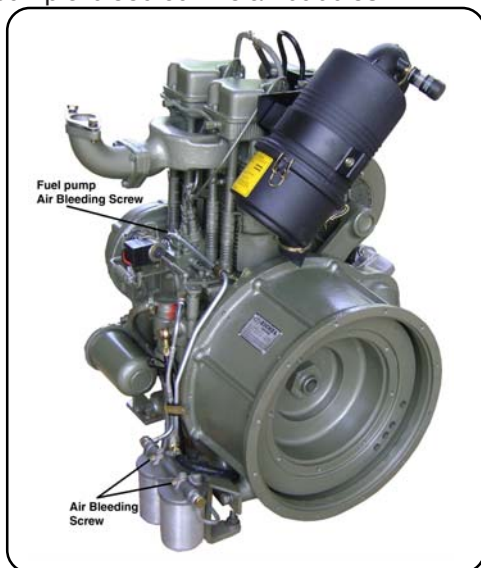

Fuel Priming by Feed Pump

INJECTOR ASSEMBLY

The injector assembly is used to atomise the fuel. At the end of compression stroke when atomised fuel is sprayed on hot compressed gases the ignition takes place & due to the combustion we get power from engine.

For healthy combustion, the injector opening pressure etc. must be perfectly OK. Poor spray/dribbling/nozzle seat leaking, will lead to generation of excessive carbon in combustion area & due to this all combustion parts will wear-out very fast. In some cases the piston ring sticks in the piston groove or melting spots on piston top which is due to poor functioning of Injector only.

Therefore timely checking of injectors is very important as specified by engine manufacturer.

The injector & other fuel equipments are checked at only Authorized service centre of BOSCH or authorized person.

Recommended atomization pressure for injector/s is 240^{+8} kg./Cm².

Important

Fuel injection equipments are very precise & expensive components. These should be checked only at the authorized service centres of respective manufacturers.

Operational Maintenance checks for fuel system:

1. Ensure that enough diesel is present in the fuel tank before starting the engine. Never run engine on an empty fuel tank as it can cause air to enter the fuel system which can harm the engine.
2. Do not use adulterated diesel as it can damage the expensive fuel equipment.
3. Fuel equipment is very expensive and precise. Do not allow unauthorized personnel to tamper with the equipment.
4. Carry out all the periodic maintenance activities as stated in the manual.
5. Periodically check the joints/connections for leakage.
6. Replace old fuel filters at specified service intervals & never use old filters while replacing the same.
7. If it is suspected that the fuel injection pump is faulty, contact the your nearest authorized service dealer.

LUBRICATION SYSTEM

It is very important that the lubrication system is properly serviced to get optimum engine performance. Contaminated, dirty or improper grade of oil can damage cylinder liner, piston rings, bush bearing & number of other components. Therefore it is advised that you strictly adhere to company recommendations.

Lubricating oil performs the following functions:

- Lubricating between moving parts.
 - Provides cooling by absorbing heat.
 - Provides sealing between combustion system components.
 - Cleans the engine by carrying away soot/sludge/debris etc.
1. The engine parts are lubricated through pressure and splash lubricating system. The engine has a gear type oil pump, it pressurizes oil & passes it through oil-filter to various engine parts. The oil is sucked through a suction screen assembly.
 2. The oil-filter assembly has a oil pressure setting system, the specified pressure is adjusted through the setting screw. The excess oil goes back to sump through small oil gallery hole of crank housing.
 3. The oil is filtered through the filter & delivered to the main oil gallery of crank housing for lubrication of main bearing front, main bearing middle (through pipe assembly), intermediate bearing housing and an oil passage through crankshaft for connecting rod big end bearings.

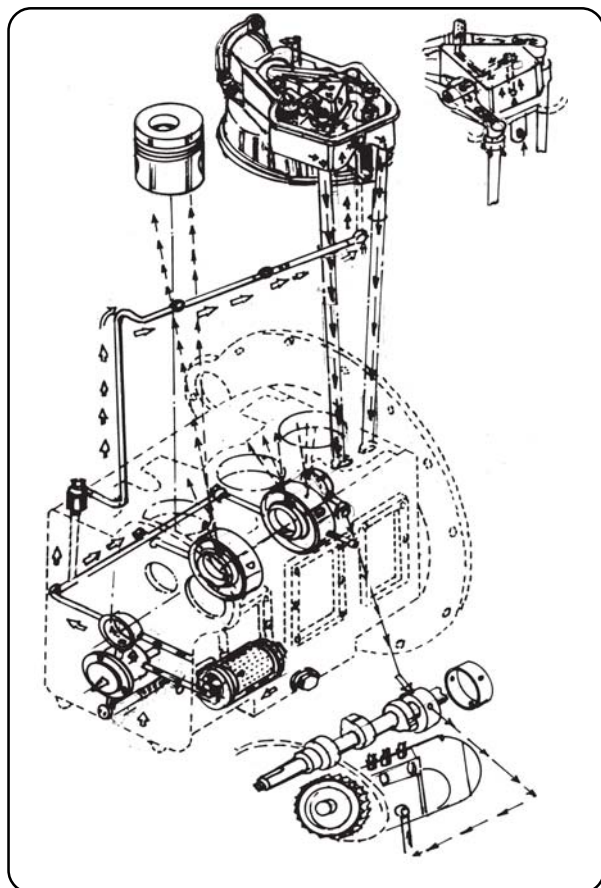

Engine Oil Circuit

4. The piston cooling nozzles are mounted in the intermediate bearing housing that spray oil under the piston crown.
5. For lubrication of rocker arm assembly, the oil goes to the cylinder head from main oil gallery through oil feed pipe. This lubricates the valve stem and surfaces over which the rocker arm moves. The oil then goes back into the sump through push rod sleeve & lifter guide holes and also lubricates the cam follower & cams before returning to the sump.
6. The gears, camshaft, ball bearings & other components are lubricated through splash.
7. A by-pass valve is also located in the oil filter assembly to ensure adequate lubrication in case the oil filter element chokes. It operates at a differential pressure of 1.1 to 1.3 kg/cm². If oil filter element gets choked then unfiltered oil will get supplied to engine. The by-pass valve will prevent immediate seizure of the engine, however dirty oil will damage costly bearings and piston rings & fast wear out of other components.

Follow Instructions :

1. Maintain correct level of oil in the engine.
2. Check oil level only when engine has been stopped and sufficient time has been allowed for engine oil to drip back to the sump. Oil level should be checked with the help of dipstick.

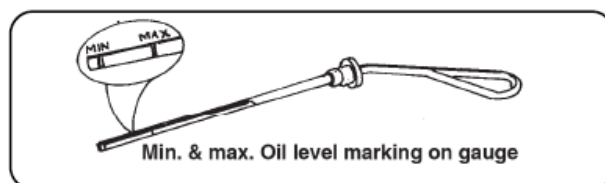

3. Ensure proper seating of dipstick in its seat before pulling it out to check the engine oil level.
4. The oil level should not be below the lower dipstick mark.
5. The upper mark on the dipstick indicates maximum (allowable) oil level in the sump.
6. If oil level is below the lower mark, then add engine oil through breather adopter.
7. The oil filter element change is very important at recommended intervals. If it is not done properly, the partially or completely unfiltered oil will go to the engine. It is essential that oil & oil filter element must be replaced at the recommended intervals.

Please Note-

- "Factory fill" punch mark has been provided on dipstick for factory filling purpose only.
- This mark is on opposite side of Min/Max level marking.

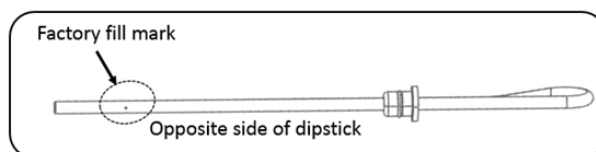

ENGINE OIL

Use only recommended grade of engine oil

"OIL SERVICE at every 500 hrs"

**USE EICHER RAKSHAK OIL
SAE 15W40 with API CI4 grade**



Specifications of other make engine oil :

SAE 15 W40 with API CI4 grade or higher grade
(Oil service at every 250 hrs)

RECOMMENDED ENGINE OIL QUANTITY

1. 322/323 ES 8.0 ltr.

"It is essential to change oil filter element, and engine oil as per recommended schedule"

OIL AND FILTER ELEMENT REPLACEMENT

Before draining the oil from sump, run the engine at 'No' Load for 5 minutes. Allow engine oil to drip back to the sump for 30 minutes & drain the oil from crank case as well as from the oil filter & collect in a tray.

OIL FILTER REPLACEMENT: 323 ES

1. Unscrew the spin-on oil filter assembly from oil filter head cum inspection cover & properly dispose it off.
2. Take a new spin-on oil filter assembly & apply few drops of fresh oil on its rubber sealing.
3. Screw the assembly on oil filter head cum inspection cover by normal hand pressure (light pressure). Then further give it 1/3 rotation by hand only. Do not use any tool for tightening.

CAUTION

Clean oil filter assembly and drain plug area before draining out oil and removal of components.



Oil Filter Replacment 323 ES

OIL FILTER REPLACEMENT 322 ES

1. Loosen the centre cap nut of oil filter assembly while holding the oil filter bowl and remove the bowl along with filter element from oil filter head.
2. Clean the oil filter bowl with fresh diesel and dry it.
3. Guide new oil filter element into the pot & replace the sealing ring of oil filter head.
4. Assemble the oil filter bowl back with the oil filter head ensuring proper seating of the sealing ring between bowl and filter head.
5. Replace cap nut 'O' ring & tighten the nut at 3.5 kgf-M.

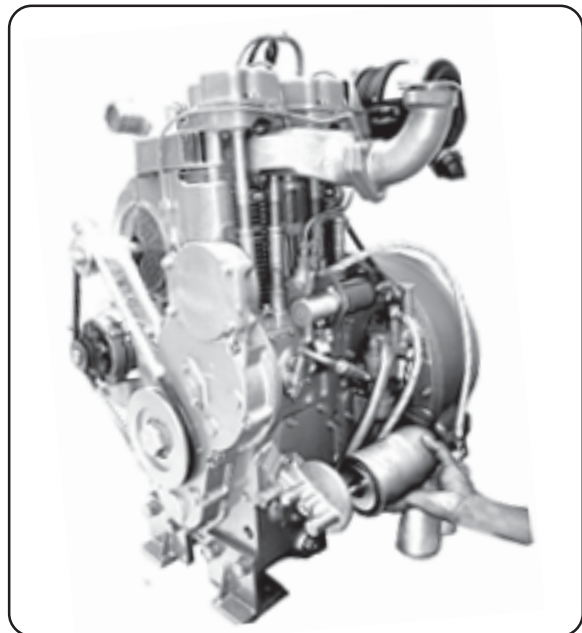

Oil Filter Replacment 322 ES

Filling fresh oil in the sump

- Clean drain plug, check the 'O' Ring & replace if required. Torque the drain plug to 4 Kgf-m torque.
- Fill fresh engine oil of recommended grade through the oil filler neck.
- Below the oil filler neck there is a baffle plate that is to be taken out before filling the oil and to be re-fitted at the same place after filling.
- Check oil level by dipstick and ensure that it is near max.(H) mark.

CAUTION

"Use only genuine oil filter element."

Dispose off old filters and oil by safe and efficient processes for protection of our environment against pollution to make our environment healthy for all.

Checking of Oil Pressure

Engine oil pressure is a very sensitive parameter that affects engine life. The 322/323 ES engine model has a **LLOP (LUBE Oil SENSOR-CUM-SWITCH)**, which is mounted on the oil gallery and is connected to the Engine/DG Controller. The LLOP has two functions:

1. Transmit signals to the "Oil pressure Gauge"/ Controller which indicates the oil pressure value.
2. Functions as an engine safety device i.e. at any time if the oil pressure is lower than the specified limit, it transmits a signal to the controller & the engine is stopped immediately. This is accompanied with blinking of the indicator light. This safety device will not work when engine is running in manual mode.

The lowest oil pressure specified is 1.0 Kg/sq.cm & the maximum oil temperature specified is 125 deg C. If the oil pressure is below the limit then diagnose the problem before using the engine.

Oil Pressure Switch (LLOP): The two poles LLOP has two terminals:

G - Gauge (connected to oil pressure gauge), &
WK - Switch (connected to warning indicator).

TERMINAL'S CONNECTION AND CHECKING FUNCTIONING

1. If engine is not in running condition then connect the multi meter between **WK** & Earthen to body, it will indicate **NC**.

Recommendations for Resistance at various oil pressures are as;

1. Resistance at 6 Bar = 124+/-5 Ohm
2. Resistance at 4 Bar = 88+/-4 Ohm.
3. Resistance at 2 Bar = 52+/-4 Ohm
4. Warning Pressure = 0.7+/-0.15 Ohm .

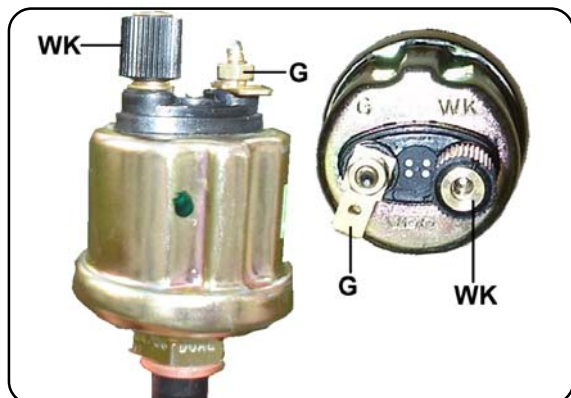

2. If engine is in running condition then connect the multi meter between **WK** & Earthen to body, it will indicate **NO** that means oil pressure is **OK**. If engine is in running condition switch circuit will be always in open condition (**NO**).

Precautions to be taken while replacing LLOP:

1. Before starting the work, ensure engine is not in running condition.
2. If selector switch is in auto mode, change it to its manual mode.
3. Disconnect the battery terminals.
5. Screw 2-pole LLOP on the engine with sealing washer. Tighten carefully to ensure there is no oil leakage from threads.
7. Connect **W** wire to '**WK**' terminal of LLOP, & '**T**' terminal wire on the '**G**' (using snap-on type lug), if it is not available then secure wire by hex. brass nut (provided at '**G**' terminal).
8. Verify '**NC**' & '**NO**' condition as explained above.
9. Ensure gauge is working.

“Ensure that there is no oil leakage from any joint before checking oil pressure”



LLOP Mounting on Engine

OIL PRESSURE ADJUSTMENT IN 322/ 323 ES

In 322/323 ES the pressure setting arrangement is provided in the oil filter head cum inspection cover plate (see fig.). There is no external adjusting arrangement (adjusting screw etc.), it is controlled automatically.

If pressure related problems occur then open the bottom cap screw and take out spring & steel ball and check all the components as explained below:

1. Check spring condition. Check for fibres or any other foreign material between spring coils & remove them .
2. If spring coils are deformed or bulged or have improper spring stiffness, then it must be replaced.

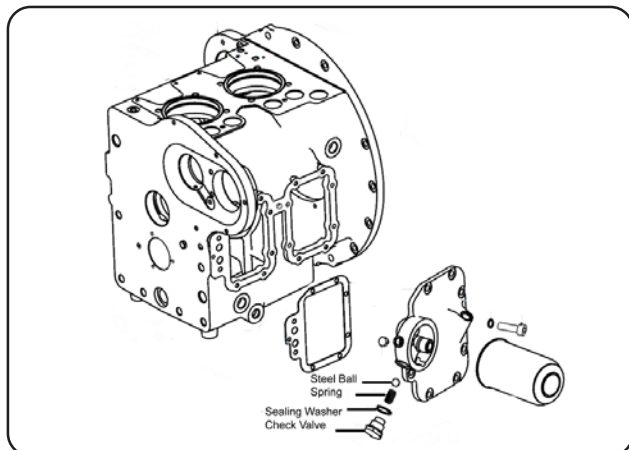

Oil pressure Adjustment in 323 ES

3. Check the steel ball & its resting seat for proper contact, it may be checked by following steps:
 - (i) Rest the steel ball on its seat, plug the by pass hole of oil filter head (just above the steel ball) by thumb & pour a small quantity of diesel on the ball,
 - (ii) The diesel does not leak out directly between ball & seat.
 - (iii) If it leaks slowly in 8 to 10 seconds, it indicates seat & ball O.K. and
 - (iv) If it leaks quickly then it may be corrected by slightly tapping the steel ball
 - (v) Finally it needs to be re-verified for leakage.
4. If the oil pressure is still below the limit, then other assemblies need to be checked. Please contact nearest authorized service dealer.

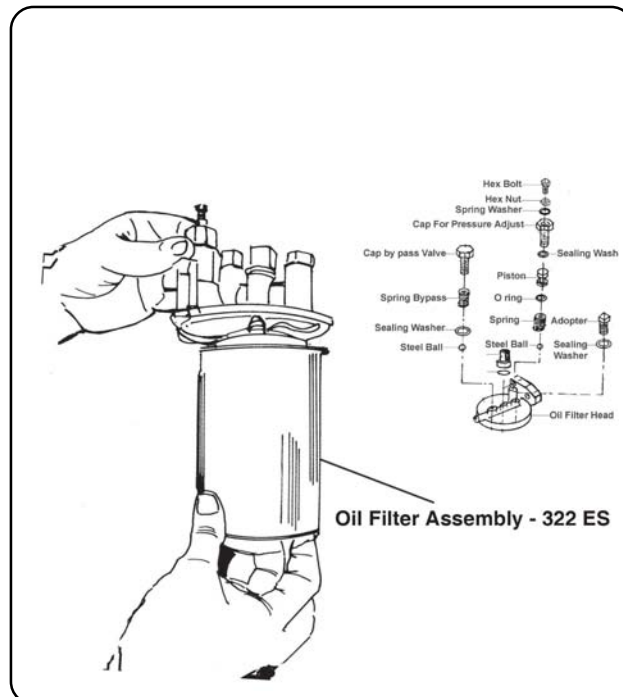

Oil Pressure Adjustment in 322 ES

TAPPET ADJUSTMENT

Tappet clearance has a direct impact on engine performance.

1. If the valve clearance is too less, the valves will open early and will close late resulting in loss of engine power.

2. Too much valve clearance causes a lag in valve timing, which throws the engine out of balance. The air is late in entering into the cylinder during the intake stroke. Hence, the valves close with great impact resulting in cracking or breaking of the valves and scuffing of the cam and follower. The valves themselves get damaged when valve clearance is not properly adjusted. Therefore tappet clearance must be checked in every service or whenever the engine is not performing well.

MODEL	TAPPET CLEARANCE	
	INLET VALVE	EXHAUST VALVE
322 ES	0.15 mm	0.15 mm
323 ES	0.15 mm	0.15 mm

Check the valve clearances as per firing order of the engine.

CAUTION

Do not check or adjust tappet clearance when engine is too hot or too cold.

Following procedure should be followed for checking the tappet clearance:

1. Rotate the engine clockwise and bring the piston (of the concerned cylinder) in compression stroke. During compression stroke, both the valves are fully closed and both the push rods are free to rotate.
2. The tappet clearance should be checked with the help of specified feeler gauge (0.15mm). For checking the clearance between the valve stem & the rocker arm, insert the specified feeler gauge strip between them (gauge value would be according to the engine model). Then push & pull the strip forward & backward.
3. The specified strip should neither be too loose nor too tight between them. If it is loose or tight, then adjust the tappet clearance.
4. To adjust the tappet clearance, first loosen the lock nut and then adjust the tappet screw according to the feeler gauge. Hold the tappet screw by a screw driver till the final adjustment is made & then tighten the lock nut. Finally ensure that the clearance value is within specified limits.
5. And after taking out the feeler gauge strip, ensure that both the push rods are free to rotate.

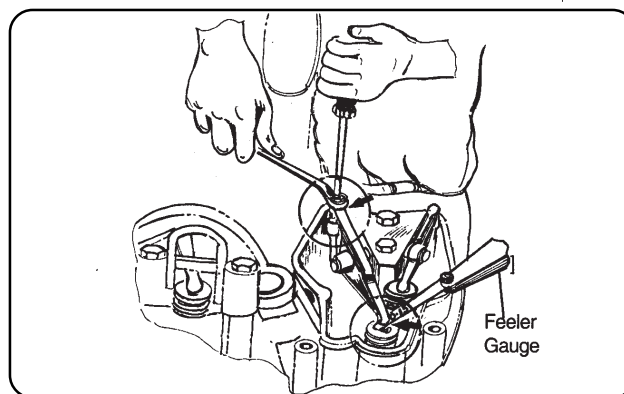

Adjustment of Tappet Clearance

CHECKING & ADJUSTMENT OF V-BELT

Correct tension of V-belt is necessary for getting optimum engine performance. A loose belt directly impacts the blower speed and can lead to over-heating of the engine. A loose belt slips more and heats up because of which the rubber binding properties are lost & the belt wears out. Over tightening the belt can also damage it & can generate extra pressure on the ball bearings and the blower shaft. The blower and battery charging alternator pulleys take drive from crank pulley with the help of V-belt. The belt should neither be too tight nor too loose. If the V-Belt is worn out or damaged, it should be replaced immediately.

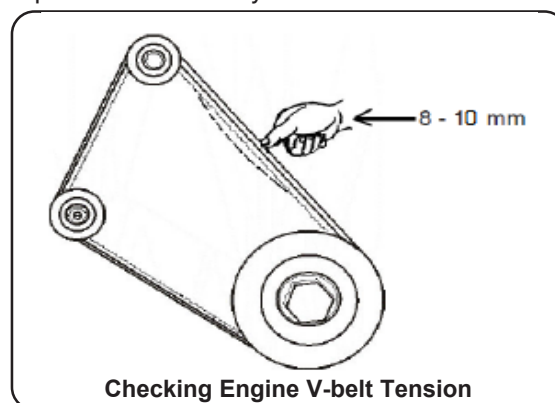

Checking Engine V-belt Tension

To ensure maximum belt life, it is recommended to "use a Belt Tensioner Gauge" for checking the belt tension. The correct tension is 350 newton (35Kgf). If the tension is below 215 newton (21 Kgf) adjust it.

If the gauge is not available, then press down the belt with the right hand thumb at the centre of the longest free length, check the belt deflection with a thumb pressure of 4.5 Kgf. The deflection should be 8 to 10 mm at the centre.

To adjust the belt tension, loosen the bolt of adjusting latch & bracket, swing the idler pulley assembly or alternator inward or outward as required. After adjusting the belt tension re-tighten the bolt.

CAUTION

**Check & adjust belt tension at only normal room temperature,
Do not spill oil/grease on V Belt**

ENGINE TEMPERATURE SAFETY

322 ES & 323 ES engine models have an electric switch that is mounted in the 1st cylinder liner that indicates liner temperature. If the liner temperature exceeds the manufacturer's specified limit, the temperature switch transmits a signal to the engine controller & the engine stops immediately. This is accompanied by blinking of the indicator light.



This is a warning system for the operator. If the operator attempts to restart the engine without diagnosing the problem, the engine will not start. Therefore it is advised to carefully diagnose the reason of the warning before re-starting the engine.

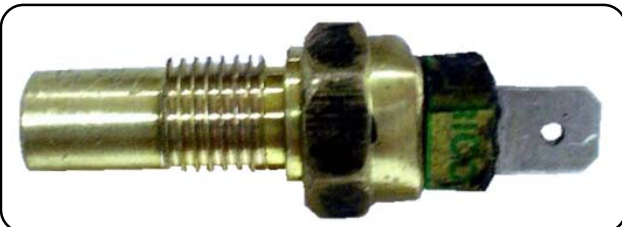

Temperature Switch

It is recommended that the engine or generator set should not be operated in manual mode (by passing the controller) as engine safety systems don't function in manual mode.

The specified range of engine cylinder liner temperature is 215°C. The functioning of the temperature switch can easily be checked by a multimeter.

1. If multi meter is connected between temperature switch terminal & its body(earth), the multi meter will indicate **NO** (normal open). Therefore if temperature is less than 215°C, the switch circuit will be in open condition.
2. When the engine temperature crosses the limit of 215°C, the switch circuit will be closed; meaning the multi meter will indicate **NC** (normal closed).

Therefore, whenever the temperature exceeds 215°C, the "Temperature switch" transmits a signals to the controller. The controller then sends a command to the stop solenoid to energize it & stop the engine.

SOLENOID ASSEMBLY

322 ES & 323 ES engines are stopped through the solenoid assembly. It is directly connected to fuel cut off lever.

In 322 ES model stop-solenoid is push type, while 323 ES is pull type.

The energising specified time (engine stopping time) is 15 to 20 seconds for both the models. The hammer travelling length can be easily adjusted by its screwing and locking arrangement of link rod. After final adjustment the nut must be locked, other wise it may start mal functioning.

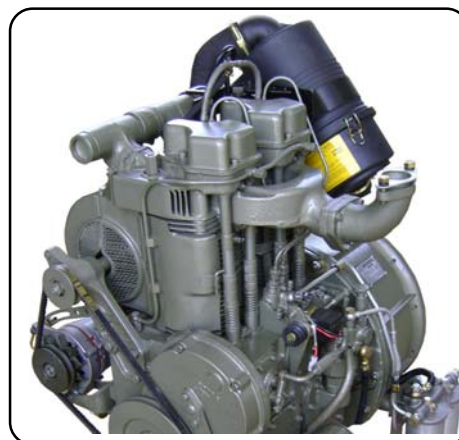

Solenoid Assembly 322 ES



Solenoid Assembly 323 ES

ELECTRICAL SYSTEM: BATTERY

Battery acts as a source of electricity and allows the self-starter motor & ignition system to perform their respective functions. It provides electrical power to the motor and the ignition system and helps in cranking the engine. It also acts as a voltage stabilizer for the electrical system. The following precautions need to be taken when connecting the battery with the engine:

1. Always keep the battery on a stand.
2. Maximum cable length should not be more than 1 meter and minimum cable size should be at least 35 mm²
3. If the battery to self starter cable length is more than 1 meters, then use cables of a higher size . The voltage drop due to the cable should not be more than 0.5 Volts.
4. Ensure correct polarity connections at battery terminals
5. Do not check battery charging by 'live' flashing the cable leads on the engine body or any other part.

Factors affecting battery life

1. Over charging
2. Under charging
3. High specific gravity
4. Impure top-up water
5. Neglecting top-up
6. Container damage
7. Leaving battery idle

Battery health check

Step 1- Check open circuit voltage (OCV) by multimeter

1. If in open circuit, the voltage is more than 12.5 volts, it indicates that the battery is fully charged.
2. If voltage is between 12.0 - 12.4 volts, it indicates that the battery is partially discharged & needs to be bench charged.
3. If voltage is less than 12.0 volts, it indicates that the battery is fully discharged.

Step 2- Specific gravity check by hydrometer

1. If the battery's specific gravity is more than 1.250, add distilled water to bring the specific gravity between 1.230 - 1.240.
2. A specific gravity between 1.230 - 1.240 indicates that the battery is fully charged.
3. If the specific gravity is between 1.200 - 1.220, it indicates that the battery is partially discharged & needs bench charging.
4. If the specific gravity is less than 1.200, it indicates that the battery is completely discharged. Kindly arrange to get the battery repaired at an authorized service centre.



Battery maintenance

1. Clean & remove the greenish white powder deposits on the battery & the cable terminals by using hot water during service or on need basis.
2. Keep the vent plug holes clean & properly tightened at their respective locations.
3. Check the electrolyte level in each cell every week. This level should be between the marked battery minimum & maximum level. If the level is below the minimum mark, kindly add distilled water. Never use tap water to fill the battery.
4. Do not over fill the electrolyte when topping up as it will start over-flowing when the battery is charged.
5. Apply petroleum jelly on the terminals after fully tightening them. Never use grease on the terminals.
6. During service, check the specific gravity of electrolyte in each cell using a hydrometer and adhere to the specifications that are mentioned above.

Battery Rating for DG Sets from 5 kVA to 125 kVA Rating

DG Set kVA Rating	Battery Rating	Battery Lead Conductor Rating
5	12 VDC, 65 AH	35 sq. mm. Copper - Upto 1 m
7.5	12 VDC, 65 AH	35 sq. mm. Copper - Upto 1 m
10	12 VDC, 88 AH	35 sq. mm. Copper - Upto 1 m
15	12 VDC, 88 AH	35 sq. mm. Copper - Upto 1 m
20	12 VDC, 88 AH	35 sq. mm. Copper - Upto 1 m
25	12 VDC, 88 AH	35 sq. mm. Copper - Upto 1 m
30	12 VDC, 88 AH	35 sq. mm. Copper - Upto 1 m
35	12 VDC, 88 AH	35 sq. mm. Copper - Upto 1 m
40	12 VDC, 100 AH	35 sq. mm. Copper - Upto 1 m
45	12 VDC, 100 AH	35 sq. mm. Copper - Upto 1 m
50	12 VDC, 100 AH	35 sq. mm. Copper - Upto 1 m
62.5	12 VDC, 100 AH	35 sq. mm. Copper - Upto 1 m
75	12 VDC, 130 AH	35 sq. mm. Copper - Upto 1 m
82.5	12 VDC, 130 AH	35 sq. mm. Copper - Upto 1 m
100	12 VDC, 130 AH	35 sq. mm. Copper - Upto 1 m
125	12 VDC, 130 AH	35 sq. mm. Copper - Upto 1 m

FAULT DIAGNOSIS			
THE FAULT DIAGNOSIS CAN BE DONE WITH HELP OF BELOW GIVEN LIST OF POSSIBLE CAUSES			
PROBLEM		POSSIBLE CAUSES	
		CHECKS BY USER	CHECKS BY AUTHORIZED PERSON
Engine does not crank		1,2,3	3,58
Engine fails to start		1,2,3,5,6,8,9,10,12	13,35,36,37,38,39,40,42,43,44
Engine hard starting		3,5,8,9,10,11,12, 13,16,17,19	35,36,37,38,40,42,43,44
Low power/not taking load		5,8,9,10,11,12,13,16, 17,18,19,20	35,36,37,38,39,42,43,44,54
Engine misfires		8,9,10,12,13	22,35,36,37,38,39,40,41,43
Excessive fuel consumption		5,11,13,18,19,21	22,35,36,37,38,39,40,42,43,44,54
Excessive oil consumption		4,21,23	31,33,34,38,42,43,44,52
Excessive black smoke		5,11,13,19,21	22,35,36,37,38,39,40,42,43,44,54,59
Low oil pressure		4,24,25,20	17,32,46,47,48,49,50,51,55,59
Engine knocking		5,9,13,20	22,29,34,36,37,40,42,44,46,52
Erratic behaviour of engine		7,8,9,10,11,12,13,16,18,20	22,34,35,38,40,41,44,52,58
Excessive vibration		13,18,27,28	26,35,38,39,40,41,44,52
Engine temperature too high/overheating		11,13,15,19,23,27,30	14,15,35,36,37,39,45,52,53,60
Excessive blow by		4,21,23,31	33,39,42,44,52
Poor compression		11	22,29,33,34,37,39,40,42,43,44
Charging alternator not working		53	56
Diesel dilution in engine oil		5,8,9,16	13,34,35,52
LIST OF POSSIBLE CAUSES			
S. No	CAUSES	S. No	CAUSES
1.	Battery discharged/improper capacity	34.	Valve spring is broken
2.	Wrong electrical connections	35.	Faulty fuel injection pump
3.	Faulty self-starter	36.	Incorrect timing of fuel injection pump
4.	Use of Wrong grade of lubricating oil	37.	Incorrect valve timing
5.	Adulterated fuel/poor quality of fuel	38.	Low compression pressure
6.	Fuel tank empty	39.	Cylinder head gasket leakage
7.	Solenoid not working properly	40.	Push rod movement tight
8.	Choked/restricted fuel lines	41.	Wrong high pressure pipes
9.	Faulty fuel feed pump	42.	Worn cylinder bores
10.	Choked fuel filter element	43.	Leakage between valves and seats
11.	Choked air cleaner element	44.	Piston rings worn or not free in grooves
12.	Air lock in fuel system	45.	Fault in thermostat/radiator fan defective.
13.	Injector malfunctioning	46.	Crank shaft bearings are worn or damaged
14.	Choked cooling passage	47.	Worn out lubricating oil pump
15.	Water pump defective	48.	Relief valve does not close
16.	Choked breather/vent of fuel tank	49.	Relief valve does not open
17.	LLOP faulty	50.	Relief valve spring is broken
18.	Governor linkages sticky	51.	Fault in suction pipes in lubricating oil pump
19.	Restricted exhaust pipe	52.	Piston scuffing/scoring
20.	Engine temperature is too high	53.	"V" Belt loose or damaged
21.	Engine temperature is too low	54.	Intake air leakage
22.	Tappet setting wrong	55.	Oil filter clogged/oil galleries blocked
23.	Excessive oil level in oil sump	56.	Charging alternator faulty
24.	Low oil level in oil sump	57.	Indicating lamp-bulb fuse
25.	Defective gauges	58.	Faulty ESU/GCU
26.	Flywheel housing/flywheel not aligned	59.	Engine overloading
27.	Power transmitting coupling misaligned	60.	Blower fan faulty/hot air recirculation/exh. leak.
28.	Improper foundation/mounting bolt loose		
29.	Bumping clearance wrong		
30.	Restriction in cylinder head/block passages		
31.	Restriction in breather pipe		
32.	Restriction in sump strainer		
33.	Valve system and guides are worn		

GENERAL FAULTS & DIAGNOSIS

A. STARTER MOTOR NOT CRANKING/TOO SLOW

1. Loose or broken wire.
2. Battery discharged.
3. Starter motor defective.

B. ENGINE FAILS TO START

1. Fuel tank empty.
2. Air lock in fuel system
3. Clogged fuel filter or pipe.
4. Injector malfunctioning.
5. Defective feed pump.
6. Incorrect injection timing.
7. Low compression pressure.
 - a) Cylinder head valve leakage.
 - b) Piston rings sticking.
 - c) Cylinder head gasket damaged.
 - d) Broken valve spring.
8. Over flow valve defective.
9. Stop lever not in drive position.
10. Improper setting of stop solenoid.

C. ENGINE STARTS BUT STOPS AFTER A SHORT WHILE

1. Air in injection pump, pipes or injectors.
2. Clogged fuel filter or pipe.
3. Defective feed pump
4. Faulty stop solenoid.

D. ERRATIC BEHAVIOUR OF ENGINE

1. Air lock in fuel system.
2. Clogged fuel filter or pipes.
3. Leakages in fuel inlet or delivery pipe.
4. Injectors malfunctioning.
5. Low compression pressure.
6. Defective feed pump.
7. Defective Injection pump or governor.

E. NOT TAKING LOAD

1. Clogged air cleaner element.
2. Accelerator linkage incorrectly adjusted/
Loose linkage.
3. Air lock in fuel system
4. Clogged fuel filters/ fuel pipes.
5. Injectors defective.
6. Leakage in fuel inlet or delivery pipe.
7. Incorrect injection timing.
8. Feed pump defective.
9. Low compression pressure.
10. Fuel Injection pump or governor defective.
11. Overflow valve defective.
12. Stop lever not properly closed.

F. ENGINE KNOCKING

1. Incorrect fuel.
2. Injectors defective.
3. Advanced injection timing.
4. Low compression.
5. Excessive bearing clearance.

G. OIL THROW FROM EXHAUST SYSTEM

1. Engine running too cold.
2. Engine idling for too long.
3. Air filter clogged.
4. Incorrect fuel.
5. Engine oil level too high.
6. Leakage in fuel pipes.
7. Clogged fuel filter or fuel pipe.
8. Injectors defective.
9. Incorrect injection timing.
10. Low compression.
11. Injection pump or governor defective.
12. Engine operation at low loads.

H. ENGINE OVERHEATING

1. Slack or broken fan belt.
2. Blower fan faulty.
3. Liner fins clogged.
4. Hot air re-circulation.
5. Exhaust gas leakage.
6. Overloading.

I. ENGINE OVERSPEEDING

1. Governor defective.

J. LOW OIL PRESSURE

1. Low oil level.
2. Wrong grade of engine oil.
3. Adulterated/contaminated engine oil.
4. Choked control valve.
5. High oil temperature.
6. Excessive bearing clearance.
7. Idling speed too low.
8. LLOP faulty.
9. Oil pressure gauge malfunctioning.
10. Oil filter clogged.
11. Extended oil change interval.

Drawing approval subject to valid vendor registration

PERIODIC ENGINE MAINTENANCE SCHEDULE CHART

Recommended Service Schedule at every 500 hrs
with "EICHER RAKSHAK OIL" SAE 15W40 API C14 grade

Follow Schedule as per recommended hours or days whichever occurs first							
A. Every Day or after Engine running 8 Hours.							
B. First Service after 50 Hours or 15 Days							
C. After Every 500 Hours or 6 Month							
		D. After Every 1000 Hours or 12 Month					
		E. After Every 1500 Hours or 18 Month					
		F. After Every 2000 Hours or 24 Month					
S. No.	ACTIVITY	A	B	C	D	E	F
1	Check diesel level in fuel tank.	●	●	●	●	●	●
2	Check for oil/ diesel leakage.	●	●	●	●	●	●
3	Check oil level in the sump by dipstick mark. Maintain oil level upto H mark of dipstick.	●	●	●	●	●	●
4	Drain out oil from engine sump.		●	●	●	●	●
5	Fill fresh Eicher Rakshak Oil (SAE 15W40 WITH API C14 GRADE).		●	●	●	●	●
6	Replace oil filter assembly.		●	●	●	●	●
7	Check oil pressure & adjust if required.		●	●	●	●	●
8	Clean fuel feed pump bowl & its strainer.		●	●	●	●	●
9	Remove both the fuel filter shells, discard old filter elements, clean filter shells and fit new filter elements in them.			●	●	●	●
10	Replace rubber seal of both the elements and fit properly.			●	●	●	●
11	Air bleed fuel filter shells & fuel pump through the bleeding screw.		●	●	●	●	●
12	Clean air cleaner filter element by blowing air from inside to outside.		●	●	●	●	●
13	Clean air cleaner filter housing by dry cloth.		●	●	●	●	●
14	Replace air cleaner filter element (or earlier as per indicating ring.)					●	
15	Adjust tappet clearance of both valves as per specified value.		●	●	●	●	●
16	Check condition of hoses & proper tightening.		●	●	●	●	●
17	Clean the breather assembly.		●	●	●	●	●
18	Check V-Belt condition & adjust if required.		●	●	●	●	●
19	Check & tighten pedestal mounting nuts & bolts.		●	●	●	●	●
20	Check electrolyte level in each battery cell & top up if needed.		●	●	●	●	●
21	Clean battery terminals and smear them with petroleum jelly.			●	●	●	●
22	Check injectors pressure, spray pattern & dribbling at authorized service centre.						●
23	Check for exhaust gas leakages inside canopy from any joint.		●	●	●	●	●
24	Check liner fins for blockage & clean if required.		●	●	●	●	●
PRECAUTIONS:							
<ol style="list-style-type: none"> 1. Service interval of 500 hrs. to be considered as max. limit for each consecutive service. 2. The air cleaner filter choking time depends on user's environmental conditions, normal life of element is approximately 1500 hours. However, If vacuum indicator (red band) indicates choking before 500 hours (between two services) or its choking frequency trend is increasing, then replace with the new filter element. 3. According to environmental conditions, drain the water from fuel filter assembly by loosening the drain screw at the bottom of fuel filter. If humidity is more, then drain water droplets once in every 15 days. 4. In case engine is not run for 6 months or more, it is advised to change the engine oil and oil filter elements before starting the engine. 							
OTHER CHECK POINTS							
<ol style="list-style-type: none"> 1. Check starter motor and alternator functioning after 2500 hours or 2½ years. 2. De-carbonise exhaust manifold/pipes in 3000 hours or in three years whichever occurs first. 							

SERVICE ACTIVITIES SCHEDULED AT EVERY 500 hrs.

FOLLOW SERVICE SCHEDULE AS RECOMMENDED HOURS/MONTHS WHICH OCCUR FIRST

A Check Daily	B Check After 50 hrs. or 15 Days	C Check After every 500 hrs. or 6 Month	D Check After every 1000 hrs. or 12 Month	E Check After every 1500 hrs. or 18 Month	F Check After every 2000 hrs. or 24 Month
<p>General</p> <ul style="list-style-type: none"> ➤ Diesel level in Fuel tank. ➤ Ensure no oil/fuel leakage from any joint. ➤ Sump oil level (dipstick mark). ➤ Battery charging O.K. ➤ Normal Engine Noise ➤ Clean the DG/Engine with a dry piece of cloth. ➤ Keep the surrounding area neat & clean. ➤ Check fan blower guard for blockage & clean if required. 	<p>General</p> <ul style="list-style-type: none"> ➤ Repeat all 'A' checks. ➤ Clean breather assembly. ➤ Tighten mounting nuts & bolts. ➤ Check tappet clearance. ➤ Clean battery terminals & smear petroleum jelly on them. ➤ Check electrolyte level in each battery cell & top up if required. ➤ Check liner fins for blockage & clean. <p>Lubrication</p> <ul style="list-style-type: none"> ➤ Drain out sump oil & fill fresh EICHER RAKSHAK OIL (SAE 15W40 with CI 4 grade). ➤ Replace old oil filter element & sealing ring. ➤ Check oil pressure. <p>Fuel System</p> <ul style="list-style-type: none"> ➤ Clean the fuel feed pump bowl & its stainer. ➤ Drain out water droplets from fuel filter shells through drain screws. ➤ Bleed air bubbles through bleeding screw. ➤ Ensure O.K. condition of fuel pipes. <p>Air Cleaner</p> <ul style="list-style-type: none"> ➤ Remove & clean the air cleaner filter element by blowing air (inside to outside). ➤ Clean air cleaner housing. ➤ Check for leakage from any joint. ➤ Check/adjust V-Belt tension. 	<p>General</p> <ul style="list-style-type: none"> ➤ Repeat all 'A' & 'B' checks. ➤ Replace gasket or copper washers if oil or diesel leakage is observed. <p>Lubrication</p> <ul style="list-style-type: none"> ➤ Change drain plug 'O' ring. <p>Fuel System</p> <ul style="list-style-type: none"> ➤ Drain out complete diesel through drain screw from fuel filter shells before removing them. ➤ Remove primary & secondary fuel filter elements and rubber seal from head & dispose it off properly. ➤ Clean the shells and fit the new rubber seal and elements. ➤ Bleed air from shells & fuel pump through bleeding screw. <p>Air Cleaner</p> <ul style="list-style-type: none"> ➤ Ensure no cuts or cracks are present in air hose. ➤ Check tightening of air hose clamps & inlet manifold. ➤ Check/adjust V-Belt tension. <p>Exhaust system</p> <ul style="list-style-type: none"> ➤ Check for exhaust gas leakage from all joints. 	<p>General</p> <ul style="list-style-type: none"> ➤ Repeat all 'A', 'B' & 'C' checks. <p>Lubrication</p> <ul style="list-style-type: none"> ➤ Change drain plug 'O' ring. 	<p>General</p> <ul style="list-style-type: none"> ➤ Repeat all 'A', 'B' & 'C' checks. <p>Air Cleaner</p> <ul style="list-style-type: none"> ➤ Replace air cleaner filter element. 	<p>General</p> <ul style="list-style-type: none"> ➤ Repeat all 'A', 'B' & 'C' checks. <p>Fuel System</p> <ul style="list-style-type: none"> ➤ Check Injector pressure, spray pattern & dribbling at BOSCH authorized service centre. ➤ Drain & clean fuel tank.

PRECAUTIONS:

1. Service interval of **500 hrs.** to be considered as max. limit for each consecutive service.
2. The Air cleaner filter choking time depends on user's environmental conditions, normal life of element is approximately 1500 hours. If vacuum indicator (red band) indicates choking before 500 hours (between two services) or its choking frequency trend is increasing, then replace with the new filter element.
3. According to environmental conditions, drain the water from fuel filter assembly by loosening the drain screw at the bottom of fuel filter. If humidity is more, then drain water droplets once every 15 days.
4. In case engine is not run for 6 months or more, it is advised to change the engine oil and oil filter elements before starting the engine.

OTHER CHECK POINTS

1. Check Starter motor and Alternator functioning after 2500 hours or 2½ years.
2. De-carbonise exhaust manifold/pipes in 3000 hours or in three years which occurs first.

PERIODIC ENGINE MAINTENANCE SCHEDULE CHART

RECOMMENDED SERVICE SCHEDULE AT EVERY 250 HRS

with other than Eicher Rakshak Oil SAE 15W40 API CI4 grade or higher grade

Follow Schedule as per recommended hours or days which occur first

A. Every Day or after Engine running 8 Hours.

B. First Service after 50 Hours or 15 Days

C. After Every 250 Hours or 90 Days

D. After Every 750 Hours or 270 Days

E. After Every 1000 Hours or 365 Days

F. After Every 1250 Hours or 450 Days

S.No.	ACTIVITY	A	B	C	D	E	F
1	Check iesel level in fuel tank.	●	●	●	●	●	●
2	Check for oil/diesel leakages.	●	●	●	●	●	●
3	Check oil level in the sump by dipstick mark. Maintain oil level upto H mark of dipstick.	●	●	●	●	●	●
4	Drain out oil from engine sump.		●	●	●	●	●
5	Fill Fresh Lubricating Oil (SAE 15W40 API CI4 GRADE OR HIGHER GRADE).		●	●	●	●	●
6	Replace oil filter assembly.		●	●	●	●	●
7	Check oil pressure & adjust if required.		●	●	●	●	●
8	Clean fuel feed pump bowl & its strainer.		●	●	●	●	●
9	Remove both the fuel filter shells, discard filter elements, clean filter shells and fit new filter elements in them.			●	●	●	●
10	Replace rubber seal of both the elements and fit properly.			●	●	●	●
11	Air bleed fuel filter shells & fuel pump through the bleeding screw.		●	●	●	●	●
12	Clean air cleaner filter element by blowing air from inside to outside.		●	●	●	●	●
13	Clean air cleaner filter housing by dry cloth.		●	●	●	●	●
14	Replace air cleaner filter element (or earlier as per indicating ring).					●	
15	Adjust tappet clearance of both valve as per specified Value.		●	●	●	●	●
16	Check condition of hoses & proper tightening.		●	●	●	●	●
17	Clean the breather assembly.		●	●	●	●	●
18	Check V-Belt condition & adjust if required.		●	●	●	●	●
19	Check & tighten pedestal mounting nuts & bolts.		●	●	●	●	●
20	Check electrolyte level in each battery cell & top up if needed.		●	●	●	●	●
21	Clean battery terminals and smear them with petroleum jelly.			●	●	●	●
22	Check Injectors pressure, spray pattern & dribbling at authorized service centre.						●
23	Check for exhaust gas leakages inside canopy from any joint.		●	●	●	●	●
24	Check liner fins for blockage & clean if required		●	●	●	●	●

PRECAUTIONS:

- Service interval of **250 hrs.** to be considered as max. limit for each consecutive service.
- The Air cleaner filter choking time depends on user's environmental conditions, normal life of element is approximately 1000 hours. However, If vacuum indicator (red band) indicates choking before 250 hours (between two services) or its choking frequency trend is increasing, then replace with the new filter element.
- According to environmental conditions, drain the water from fuel filter assembly by loosening the drain screw at the bottom of fuel filter. If humidity is more, then drain water droplets once every 15 days.
- In case engine is not run for 3 months or more, it is advised to change the engine oil and oil filter elements before starting the engine.

OTHER CHECK POINTS

- Check starter motor and alternator functioning after 2500 hours or 2½ years.
- De-carbonise exhaust manifold/pipes in 3000 hours or in three years which occurs first.

SERVICE ACTIVITIES SCHEDULED AT EVERY 250 hrs.

FOLLOW SERVICE SCHEDULE AS RECOMMENDED HOURS / MONTHS WHICH OCCUR FIRST

A Check Daily	B Check After 50 hrs. or 15 Days	C Check After every 250 hrs. or 90 Days	D Check After every 750 hrs. or 270 Days	E Check After every 1000 hrs. or 365 Days	F Check After every 1250 hrs. or 450 Days
<p>General</p> <ul style="list-style-type: none"> ➤ Diesel level in Fuel tank. ➤ Ensure no oil/fuel leakage from any joint. ➤ Sump oil level (dipstick mark). ➤ Battery charging O.K. ➤ Normal engine noise. ➤ Clean the DG/engine with a dry piece of cloth. ➤ Keep the surrounding area neat & clean. ➤ Check fan blower guard for blockage & clean if required. 	<p>General</p> <ul style="list-style-type: none"> ➤ Repeat all 'A' checks. ➤ Clean breather assy. ➤ Tighten mounting nuts & bolts. ➤ Check tappet clearance. ➤ Clean battery terminals & smear petroleum jelly on them. ➤ Check electrolyte level in each battery cell & top up if required. ➤ Check liner fins for blockage & clean <p>Lubrication</p> <ul style="list-style-type: none"> ➤ Drain out sump oil & fill fresh LUBRICATING OIL (SAE 15W40 with CI4 grade or higher grade). ➤ Replace old oil filter element & sealing ring. ➤ Check oil pressure. <p>Fuel System</p> <ul style="list-style-type: none"> ➤ Clean the fuel feed pump bowl & its stainer. ➤ Drain out water droplets from fuel filter shells through drain screws. ➤ Bleed air bubbles through bleeding screw. ➤ Ensure O.K. condition of fuel pipes. <p>Air Cleaner</p> <ul style="list-style-type: none"> ➤ Remove & clean the air cleaner filter element by blowing air (inside to outside). ➤ Clean air cleaner housing. ➤ Check for leakage from any joint. ➤ Check/adjust V-Belt tension. 	<p>General</p> <ul style="list-style-type: none"> ➤ Repeat all 'A' & 'B' checks. ➤ Check tappet clearance. ➤ Replace gasket or copper washers if oil or diesel leakage is observed. <p>Lubrication</p> <ul style="list-style-type: none"> ➤ Change drain plug 'O' ring. <p>Fuel System</p> <ul style="list-style-type: none"> ➤ Drain out complete diesel through drain screw from fuel filter shells before removing them. ➤ Remove primary & secondary fuel filter elements and rubber seal from head & dispose it off properly. ➤ Clean the shells and fit the new rubber seal and elements. ➤ Bleed air from shells & fuel pump through bleeding screw. <p>Air Cleaner</p> <ul style="list-style-type: none"> ➤ Ensure no cuts or cracks are present in air hose. ➤ Check tightening of air hose clamps & inlet manifold. ➤ Check/adjust V-Belt tension. <p>Exhaust system</p> <ul style="list-style-type: none"> ➤ Check for exhaust gas leakage from all joints. 	<p>General</p> <ul style="list-style-type: none"> ➤ Repeat all 'A', 'B' & 'C' checks. <p>Lubrication</p> <ul style="list-style-type: none"> ➤ Change drain plug 'O' ring. 	<p>General</p> <ul style="list-style-type: none"> ➤ Repeat all 'A', 'B' & 'C' checks. <p>Air Cleaner</p> <ul style="list-style-type: none"> ➤ Replace air cleaner filter element. 	<p>General</p> <ul style="list-style-type: none"> ➤ Repeat all 'A', 'B' & 'C' checks. <p>Fuel System</p> <ul style="list-style-type: none"> ➤ Check injectors pressure, spray pattern & dribbling at BOSCH authorized service center. ➤ Drain & clean fuel tank.

PRECAUTIONS:

1. Service interval of **250 hrs.** to be considered as max. limit for each consecutive service.
2. The air cleaner filter choking time depends on user's environmental conditions, normal life of element is approximately 1000 hours. If vacuum indicator (red band) indicates choking before 250 hours (between two services) or its choking frequency trend is increasing, then replace with the new filter element.
3. According to environmental conditions, drain the water from fuel filter assembly by loosening the drain screw at the bottom of fuel filter. If humidity is more, then drain water droplets once every 15 days.
4. In case engine is not run for 3 months or more, it is advised to change the engine oil and oil filter elements before starting the engine.

OTHER CHECK POINTS

1. Check starter motor and alternator functioning after 2500 hours or 2½ years.
2. De-carbonise exhaust manifold/pipes in 3000 hours or in three years which occurs first.

Drawing approval subject to valid vendor registration

WARRANTY POLICY

TAFE Motors and Tractors Limited (TMTL) warrants each engine sold, to be free from defects in manufacturing, material and workmanship to the original purchaser, under the conditions of normal use and service. For details of the warranty terms, please refer to the tables below:-

I. Warranty on PG Engines for Non-Cellular Customers:-

S.No.	Product	Warranty Coverage
1	Engine (For all power generation engine models)	<ul style="list-style-type: none"> • 30 months from the date of Invoice from TMTL (or) • 24 months from the date of Installation (or) • 2500 Running Hours, whichever occurs first <p>* Non- Cellular customers can also avail the benefit of extended warranty of 5000 running hrs. The extended warranty of 5000 running hours will be applicable only if the customer uses Eicher Genuine Parts and Eicher Rakshak Oil and avails the routine services from TMTL Authorised Service Dealers only.</p>
2	Proprietary parts not manufactured by TMTL like <ul style="list-style-type: none"> • Self starter/ battery charging alternator /fuel injection pump/electrical gauges • Safeties like Solenoid/ LLOP/HCT/ HWT/ Low coolant level indicator etc . 	<ul style="list-style-type: none"> • 18 months from the date of Dispatch from TMTL (or) • 12 months from the date of Installation (or) • 2500 Running Hours, whichever occurs first. <p>The above warranty is subject to analysis of defect by the respective authorised dealer of original manufacturer</p> <ul style="list-style-type: none"> • 30 months from date of invoice from TMTL (or) • 24 months from date of installation (or) • 3600 Running Hours, whichever occurs first.

II. Warranty on PG Engines for Cellular Customers :-

S.No.	Product	Warranty Coverage
1	Engine (For all power generation engine models)	<ul style="list-style-type: none"> • 30 months from the date of Invoice from TMTL (or) • 24 months from the date of Installation (or) • 2500 Running Hours, whichever occurs first
2	Proprietary parts not manufactured by TMTL like <ul style="list-style-type: none"> • Self starter/ battery charging alternator alternator/ fuel injection pump/ electrical guages and safeties like solenoid/LLOP/HCT/HWT/Low coolant level indiacator etc. 	<ul style="list-style-type: none"> • 18 months from the date of Invoice from TMTL (or) • 12 months from the date of Installation (or) • 2500 Running Hours, whichever occurs first. <p>The above warranty is subject to analysis of defect by the respective authorised dealer of original manufacturer.</p>

However, the warranty on rubber parts like V-Belts, hoses, O-rings etc will be 6 months from the date of installation or 1000 running hours, whichever is earlier both for cellular and non-cellular customers.

This Warranty shall not apply to :

1. Normal and routine maintenance operations such as engine tune-up, fuel system cleaning etc.
2. Normal and routine replacement of service items such as Filter Elements, Oil Seals, Gaskets 'O' Ring, Rubber Parts, Hoses & V-Belts, Joints etc.
3. Parts of the engine, that have been subjected to misuse or negligent treatment, accident or which have been used in conjunction with parts/implements and equipment not made or recommended for such use, prematurely affecting the performance and reliability of the engine. The warranty in such cases shall be as per the sole judgment of the company and will be considered as final and binding.
4. Parts of the engine that have been altered or replaced in an unauthorized manner.
5. Engine has not been serviced by our authorized service dealers and as per the recommended Service schedule given in operator manual.
6. Eicher Genuine Parts and Eicher Rakshak Oil has not been used during the preventive maintenance services.

TAFE Motors and Tractors Limited's obligation under this warranty is limited to replacement without charge, of such parts, as shall be acknowledged by the company to be defective during warranty period, provided all such defective parts are returned to the concerned authorized dealer of the company at the cost of the claimant and such defective parts shall become the property of the company.

The original retail purchaser will notify an authorized dealer of company of any defect as soon as it occurs. The company will either send the parts or credit the cost of parts replaced by the authorized dealer, in case the claim is accepted by the company. The labour charges for the replacement of the defective components will be borne by the authorized dealer.

Warranty claims on proprietary items such as fuel injection equipment, instrument gauges, electrical equipment, alternator, self starter motor etc. will be directly referred to the nearest authorized dealer of the respective Manufacturer and will be subject to the analysis of the defect by the respective dealer of original manufacturer. The company shall not be liable in any manner in respect of the same.

This Warranty applies to a new engine only, if it remains with the original retail purchaser and is not resold within the warranty period.

TAFE Motors and Tractors Limited reserves the right to make any changes in design or to add any improvements on the engine at any time, without incurring any obligation to install the same on a engine previously supplied.

This warranty is expressly in lieu of any other warranty whether by law or otherwise expressed or implied, including any implied warranty of merchantability or fitness, and of any other obligation on the part of the company except such obligations as the company may have assumed in a separate written instrument.

This Warranty Policy is applicable only on Power Generation Engines manufactured by TMTL and does not apply to any other part of the Diesel Generating Set.

Should you need any assistance, please contact the Regional Offices of TMTL or the Authorised Service Dealer outlets.

7591765/2022/EMPT-FNE51
ADDRESS OF REGIONAL OFFICES

1	ANDHRA PRADESH/TELANGANA	Door No. 313, 3rd Floor, Minarva Complex, Sarojini Devi Road, Secunderabad - 500003, Andhra Pradesh	7306667970 9640096777
2	NESA (Assam, Nagaland, Manipur, Meghalaya, Arunachal Pradesh, Tripura, Mizoram)	House No. 6, Horse Race Road, Chilarai Nagar, Bhangagarh, Guwahati - 781032, Assam	9435191015 9830514350
3	BIHAR/JHARKHAND	A/9, Vivekananda Park, (Opp. Sona Apartment), Patliputra Clony, Patna - 800013, Bihar	0612-2262413 9931610263
4	CHENNAI	Gate No.1, Huzur Garden, Sembium Estate, Perambur-600011, Chennai	9445002993
5	GUJRAT	No.301,302, Sears Towers, Gulbai Tekra Road, Off.C.G.Road, Ahmedabad - 380006, Gujarat	079-40323001 079-26423106
6	HARYANA	Plot No.57, Opp. Crown Interiors, 13/1, Mathura Road, Sector 27C, Faridabad - 121003, Haryana	0129-2259905
7	KARNATAKA	No.24, 1st Floor, Harekrishna Road, Shivnanda Circle, Bangalore - 560001, Karnataka	9916605152
8	KERALA	No.32/2634, Second Floor, GNN Complex, Near Thammanam Post Office, Cochin- 682032, Kerala	9744887761
9	MADHYA PRADESH/ CHATTISGARH	Plot No. 1, Sector-D, Industrial Area, Mandideep - 462026, Distt : Raisen, Madhya Padesh	07480-407680/81 07480-407682/83/88
10	MAHARASHTRA	Flat No.10, 3rd Floor, Heera Moti Housing Society, Near Vodafone Store, Old Pune Mumbai Highway, Wakdewadi, Shivaji Nagar, Pune - 411003, Maharashtra	020-25811602
11	ODISHA	A/M 31, VSS Nagar, First Floor, Near Axis Bank VSS Nagar, Bhubaneswar- 751007 , Odisha	
12	PUNJAB	Multi Space Complex, SCO-4, Balaji Enclave, 1st Floor, Patiala Road Zirakpur - 140063, Punjab	0176-2314957
13	RAJASTHAN	Itarana Road Alwar - 301001, Rajasthan	0144-2332968/69
14	U.P (WEST)	Plot No.57, Opp. Crown Interiors, 13/1, Mathura Road, Sector 27C, Faridabad - 121003, Haryana	0129-2259905
15	U.P (EAST)	44A, 1st Floor, Laxmi Plaza, Cantonment Road, Near Burlington Crossing, Lucknow-226001, U.P	0522-3262177
16	WEST BENGAL/SIKKIM	3rd floor, 'Neela Chal' Apartment, 49/59 Prince Gulam Md. Shah Road, Kolkata - 700033, West Bengal	033-60507500

Drawing approval subject to valid vendor registration

TAFE MOTORS AND TRACTORS LIMITED

(A wholly owned subsidiary of TAFE )

ITARANA ROAD, ALWAR - 301 001 (RAJ.) INDIA

Ph. : 0144-2332968/969, 2332781/782

Fax : 0144-2333103