

NOTE: 1. DRAWING APPROVAL SUBJECT TO VALID TYPE TEST REPORTS, TO BE CHECKED DURING ACCEPTANCE TESTS

2. FOR EPC CONTRACTS ONLY

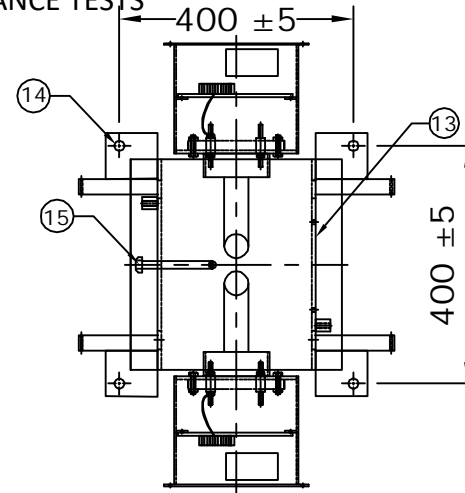
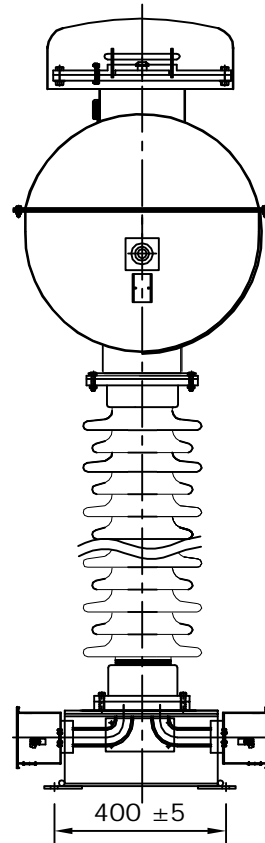
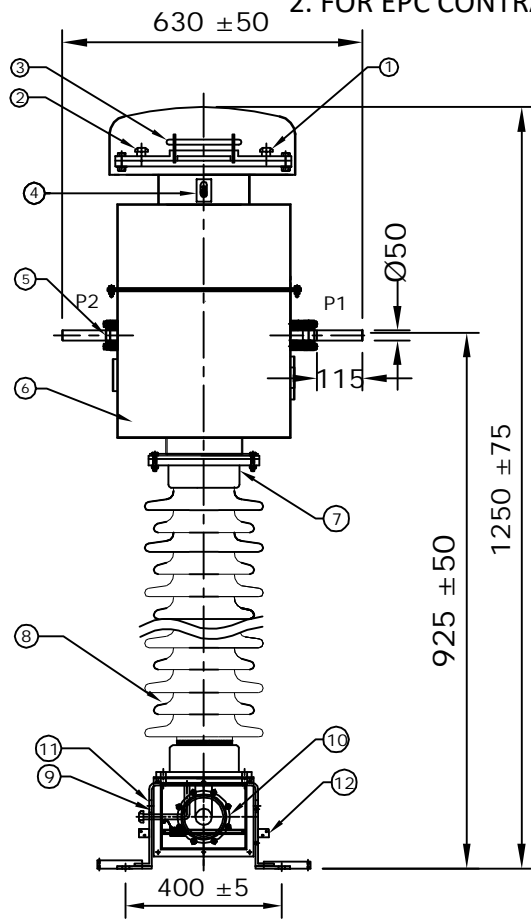

MOUNTING DETAIL

S.No.	DESCRIPTION	MATERIAL	QTY
1	OIL FILLING PLUG	M.S	1
2	NITROGEN VALVE	BRASS	1
3	PRESSURE RELEASE DEVICE	AL. + BAKELITE	1
4	OIL LEVEL INDICATOR	AL. + GLASS	1
5	PRIMARY TERMINAL Ø50x115mm	COPPER NICKEL PLATED	1
6	OIL TANK WITH COVER	M.S	1
7	BUSHING FLANGE(CEMENTED)	GI/CI	2
8	BUSHING	PORCELAIN	1
9	BASE	M.S	1
10	SECONDARY TERMINAL BOX	M.S	2
11	LIFTING HOLE Ø25mm.	M.S	4
12	EARTHING FLAT 80x50x8THICK.	M.S	2
13	NAME AND RATING PLATE	AL. ANODIZED	1
14	MOUNTING HOLE 4xØ17mm.	M.S	4
15	OIL DRAIN PLUG	M.S	1

NOTES :-

1. MAKE OF BUSHING : IEC/MODERN/BHEL/ABIL/WSI/CJI/GENESIS
2. ALL FERROUS PARTS EXPOSED TO THE ATMOSPHERE SHALL BE PAINTED WITH P.U. PAINT SHADE 631 OF IS:5
3. PRIMARY WINDING SHALL BE BAR TYPE.
4. ALL HARDWARE SHALL BE HOT DIP GALVANIZED.
5. TRANSFORMER OIL AS PER IEC : 60296.
6. ALL GASKETS SHALL BE FIXED IN PROPERLY MACHINED GROOVES.
7. ALL GASKETS SHALL BE MADE OF NITRILE BUTYL RUBBER.

- * QUANTITY OF OIL 20 LITRES APPROX.
- * TOTAL WEIGHT 135 Kgs APPROX.
- * TOTAL CREEPAGE DISTANCE :- 1116mm (Min.)

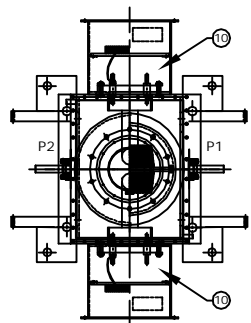

**CHIEF ENGINEER
POWER SYSTEMS, PLANNING & DESIGN
APTRANSCO**

Drawing approval subject to valid vendor registration

REV.	REVISION DESCRIPTION	DATED INITIALS
RO	FOR APPROVAL	06.01.2021

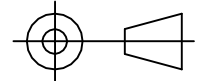
CLIENT : TRANSMISSION CORPORATION OF ANDHRA PRADESH LIMITED PROJECT NAME : AS APPLICABLE				MEHRU MEHRU ELECTRICAL & MECHANICAL ENGINEERS (P) LTD.
UNLESS OTHERWISE SPECIFIED	DATE	NAME	MATERIAL	
1. ALL DIMENSIONS ARE IN mm. 2. TOLERANCE WHEREVER NOT INDICATED ±5%	DGN. 06.01.2021 DRN. 06.01.2021 CHD. 06.01.2021 SCALE: N.T.S	SPS AKASH BLS	AS ABOVE	
TITLE : GENERAL ARRANGEMENT DRAWING FOR 33KV CURRENT TRANSFORMER RATIO:- 800-1200-2000/1-1-1-1A BAR TYPE CT				 DRG.NO ME-33CT-GA-02
SHEET No. 1 OF 6				

NOTE: 1. DRAWING APPROVAL SUBJECT TO VALID TYPE TEST REPORTS, TO BE CHECKED DURING ACCEPTANCE TESTS

8
449

2. FOR EPC CONTRACTS ONLY



LIVE TANK CURRENT TRANSFORMER

MADE TO IS: 16227

SUITABLE FOR HOT LINE WASHING

HIGHEST SYSTEM VOLTAGE	36 kV	INSULATION LEVEL		70/170 kV	
RATED S.T.C	25kA for 1 second	RATED FREQUENCY		50Hz	
NOMINAL SYSTEM VOLTAGE	33 kV	CORE 1	CORE 2	CORE 3	CORE 4
RATIO	PRIMARY(Amp)	800-1200-2000	800-1200-2000	800-1200-2000	800-1200-2000
	SECONDARY(Amp)	1	1	1	1
SECONDARY TERMINALS		1S1-1S2-1S3-1S4	2S1-2S2-2S3-2S4	3S1-3S2-3S3-3S4	4S1-4S2-4S3-4S4
RATED BURDEN IN V.A		15 VA	----	15 VA	5 VA
ACCURACY CLASS		5P	PS	0.2S	0.2S
ALF / ISF		10	----	<5 @ All Ratio	<5 @ All Ratio
Min Knee point voltage @ All Ratio		----	40 (Rct+10)V	----	----
Max Rct @ 75° C'		----	2/4/8 Ω	----	----
Max Iext @ Vk		----	50/40/30 mA	----	----
YEAR OF MANUFACTURE		2021	SERIAL NO.		

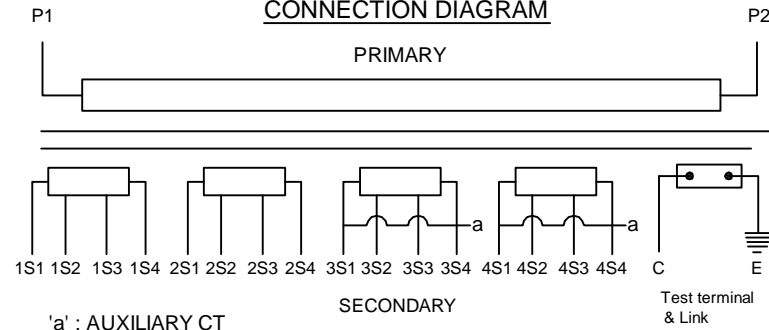

FOR RATIO	PRIMARY CONNECTION	SECONDARY CONNECTION			
		CORE I	CORE II	CORE III	CORE IV
800/1A	P1 - P2	1S1-1S2	2S1-2S2	3S1-3S2	4S1-4S2
1200/1A	P1 - P2	1S1-1S3	2S1-2S3	3S1-3S3 Short 3S3-a	4S1-4S3 Short 4S3-a
2000/1A	P1 - P2	1S1-1S4	2S1-2S4	3S1-3S4 Short 3S4-a	4S1-4S4 Short 4S4-a

CAUTION: I. Secondary terminals should be short circuited before the burden is disconnected.
 II. Test terminal 'C' must be shorted to be earth when operation
 III. Do not remove earth link when in operation

RATED CONTINUOUS THERMAL CURRENT: 120% OF THE RATED PRIMARY CURRENT

* TOTAL WEIGHT 135 Kgs APPROX. * QUANTITY OF OIL 20 LITRES APPROX.

* TOTAL CREEPAGE DISTANCE :- 1116mm (Min.)

MADE IN INDIA BY

MEHRU ELECTRICAL AND MECHANICAL ENGINEERS (P) LTD.

E-1247 RIICO INDUSTRIAL AREA , PHASE I , EXT GHATAL , BHIWADI-301 019

225 ±25

105 ±15

NOTES:-

1. THICKNESS OF RATING PLATE 1.2 mm
2. MATERIAL OF NAME PLATE SHALL BE AL. ANODIZED.
3. SERIAL NUMBER SHALL BE ENGRAVING BEFORE THE DISPATCH.

Drawing approval subject to valid vendor registration

* PRIMARY WINDING AREA : 1964 sq.mm

* CURRENT DENSITY : 1.22 A/sq.mm

CLIENT : TRANSMISSION CORPORATION OF ANDHRA PRADESH LIMITED				<p>MEHRU ELECTRICAL & MECHANICAL ENGINEERS (P) LTD.</p>
PROJECT NAME : AS APPLICABLE				
UNLESS OTHERWISE SPECIFIED	DATE	NAME	MATERIAL	
1. ALL DIMENSIONS ARE IN mm. 2. TOLERANCE WHEREVER NOT INDICATED ±5%	DGN. 06.01.2021 DRN. 06.01.2021 CHD. 06.01.2021 SCALE: N.T.S	SPS AKASH BLS	AL.ANODIZED	
TITLE :				
NAME PLATE DRAWING FOR 33kV CURRENT TRANSFORMER RATIO:- 800-1200-2000/1-1-1-1A BAR TYPE CT				
SHEET No. 3 OF 6		DRG.NO ME-33CT-NP-02		

CHIEF ENGINEER
POWER SYSTEMS, PLANNING & DESIGN
APTRANSCO

R0	FOR APPROVAL	06.01.2021
REV.	REVISION DESCRIPTION	DATED INITIALS

NOTE: 1. DRAWING APPROVAL SUBJECT TO VALID TYPE TEST

REPORTS, TO BE CHECKED DURING ACCEPTANCE TESTS

2. FOR EPC CONTRACTS ONLY

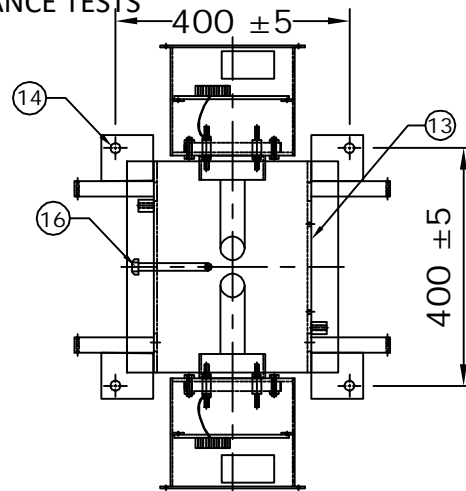
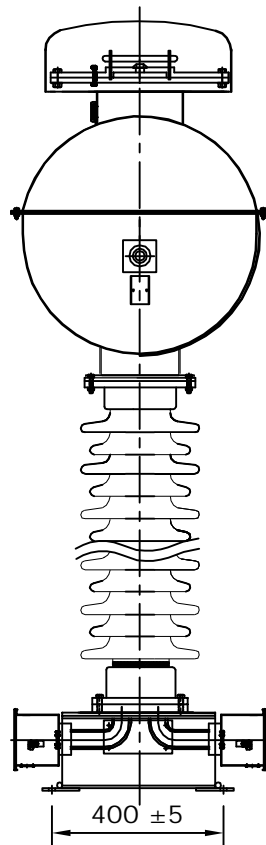
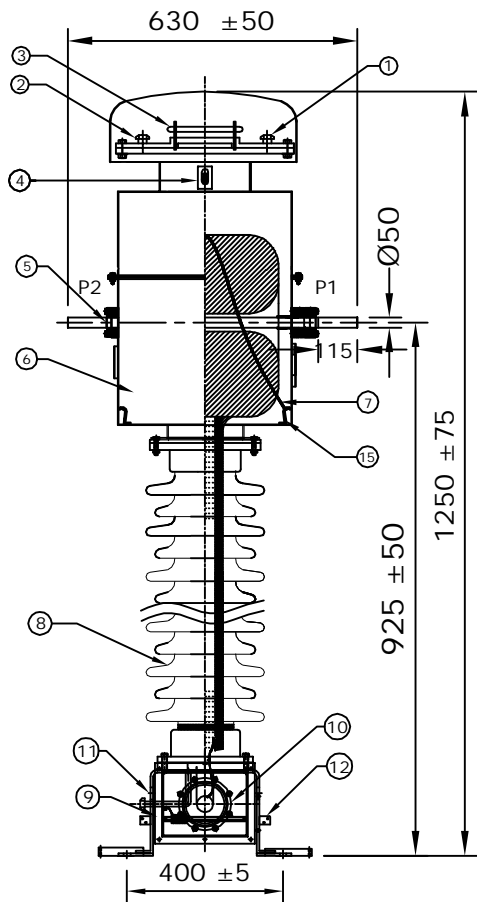

MOUNTING DETAIL

S.No.	DESCRIPTION	MATERIAL	QTY
1	OIL FILLING PLUG	M.S	1
2	NITROGEN VALVE	BRASS	1
3	PRESSURE RELEASE DEVICE	AL. + BAKELITE	1
4	OIL LEVEL INDICATOR	AL. + GLASS	1
5	PRIMARY TERMINAL Ø50x115 mm.	COPPER NICKEL PLATED	1
6	OIL TANK WITH COVER	M.S	1
7	COIL TIEING STRING	NYLON	---
8	BUSHING	PORCELAIN	1
9	BASE	M.S	1
10	SECONDARY TERMINAL BOX	M.S	2
11	LIFTING HOLE Ø25mm	M.S	4
12	EARTHING FLAT 80x50x8THICK.	M.S	2
13	NAME AND RATING PLATE	AL. ANODIZED	1
14	MOUNTING HOLE 4xØ17mm.	M.S	4
15	HOOK FOR COIL TIGHTENING	M.S	4
16	OIL DRAIN PLUG	M.S	1

NOTES :-

1. MAKE OF BUSHING : IEC/MODERN/BHEL/ABIL/WSI/CJI/GENESIS
2. ALL FERROUS PARTS EXPOSED TO THE ATMOSPHERE SHALL BE PAINTED WITH P.U. PAINT SHADE 631 OF IS:5
3. PRIMARY WINDING SHALL BE BAR TYPE.
4. ALL HARDWARE SHALL BE HOT DIP GALVANIZED.
5. TRANSFORMER OIL AS PER IEC : 60296.
6. ALL GASKETS SHALL BE FIXED IN PROPERLY MACHINED GROOVES.
7. ALL GASKETS SHALL BE MADE OF NITRILE BUTYL RUBBER.

- * QUANTITY OF OIL 20 LITRES APPROX.
- * TOTAL WEIGHT 135 Kgs APPROX.
- * TOTAL CREEPAGE DISTANCE :- 1116mm (Min.)

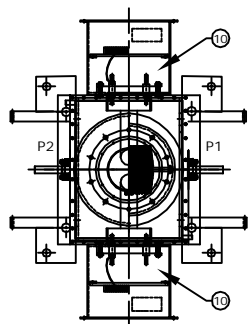

**CHIEF ENGINEER
POWER SYSTEMS, PLANNING & DESIGN
APTRANSCO**

Drawing approval subject to valid vendor registration

REV.	REVISION DESCRIPTION	DATED INITIALS
RO	FOR APPROVAL	06.01.2021

CLIENT : TRANSMISSION CORPORATION OF ANDHRA PRADESH LIMITED
PROJECT NAME : AS APPLICABLE

UNLESS OTHERWISE SPECIFIED

1. ALL DIMENSIONS ARE IN mm.
2. TOLERANCE WHEREVER NOT INDICATED ±5%

	DATE	NAME	MATERIAL
DGN.	06.01.2021	SPS	AS ABOVE
DRN.	06.01.2021	AKASH	
CHD.	06.01.2021	BLS	
SCALE:	N.T.S		

MEHRU
MEHRU ELECTRICAL & MECHANICAL ENGINEERS (P) LTD.

TITLE :
SECTIONAL ARRANGEMENT DRAWING FOR 33KV CURRENT TRANSFORMER RATIO :- 800-1200-2000/1-1-1-1A BAR TYPE CT

DRG.NO
ME-33CT-SE-02

SHEET No.
2 OF 6

NOTE: 1. DRAWING APPROVAL SUBJECT TO VALID TYPE TEST REPORTS, TO BE CHECKED DURING ACCEPTANCE TESTS
2. FOR EPC CONTRACTS ONLY

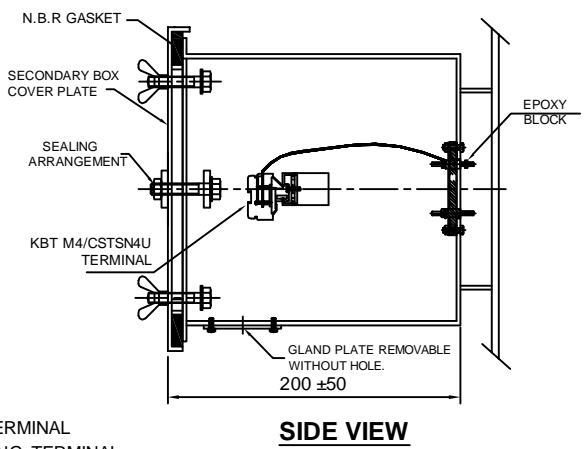
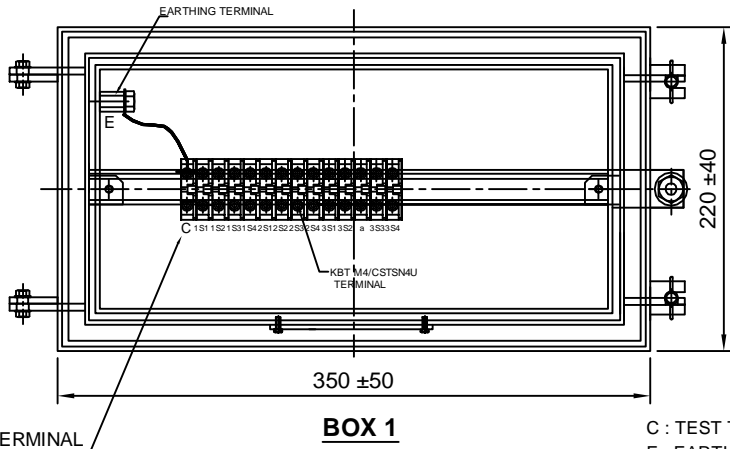
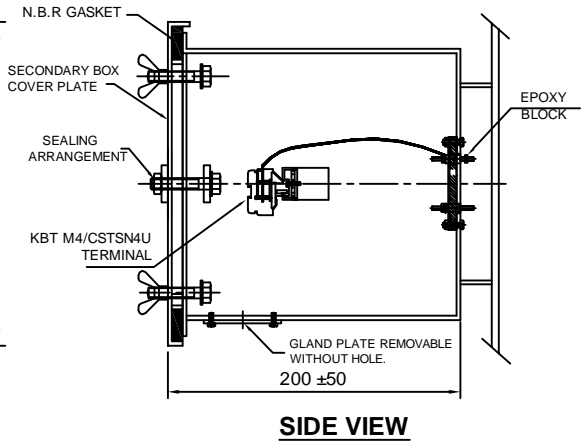
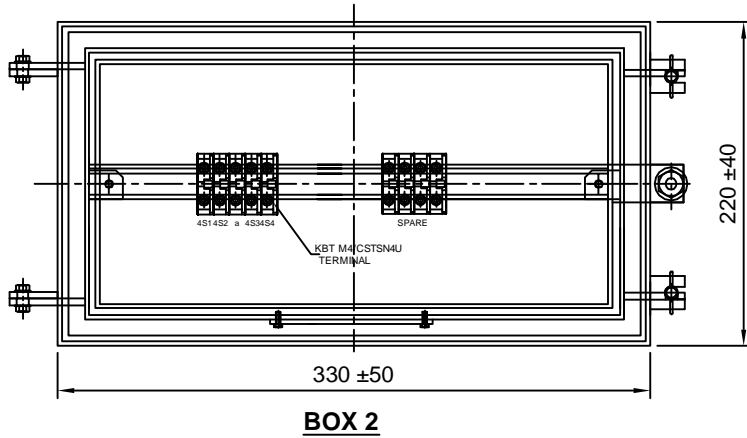

TEST TERMINAL

C : TEST TERMINAL
E : EARTHING TERMINAL
'a' : AUXILIARY CT

NOTES:-

1. SECONDARY TERMINAL BOX SHALL BE PROVIDE GLAND PLATE REMOVABLE WITHOUT HOLE.
2. SECONDARY TERMINAL BOX SHALL BE PROVIDED WITH COVER.
3. MS SHEET THICKNESS FOR TERMINAL BOX 3.0mm & FOR COVER 2.0mm.
4. MATERIAL OF GASKET : NITRILE BUTYL RUBBER GASKET.
5. DEGREE OF PROTECTION : IP 55
6. 20% SPARE TERMINAL SHALL BE PROVIDED.

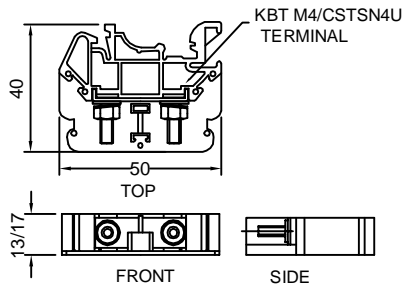

MATERIAL: POLYAMIDE
MAKE: ELMEX/CONNECTWELL

RO	FOR APPROVAL	06.01.2021
REV	REVISION DESCRIPTION	DATED INITIALS

**CHIEF ENGINEER
POWER SYSTEMS, PLANNING & DESIGN
APTRANSCO**

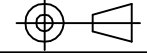
CLIENT : TRANSMISSION CORPORATION OF ANDHRA PRADESH LIMITED PROJECT NAME : AS APPLICABLE			
UNLESS OTHERWISE SPECIFIED	DATE	NAME	MATERIAL
1. ALL DIMENSIONS ARE IN mm.	DGN: 06.01.2021	SPS	M.S
2. TOLERANCE WHEREVER NOT INDICATED ±5%	DRN: 06.01.2021	AKASH	
	CHD: 06.01.2021	BLS	
	SCALE: N.T.S		
TITLE :			 MEHRU ELECTRICAL & MECHANICAL ENGINEERS (P) LTD.
SECONDARY TERMINAL BOX DRAWING FOR 33kV CURRENT TRANSFORMER RATIO:- 800-1200-2000/1-1-1-1A BAR TYPE CT			
SHEET No. 4 OF 6			 DRG NO ME-33CT-STB-02

Guaranteed Technical Particulars for 33kV Current Transformer			
Sl. No.	Item Description	Unit	GTP as per Bid
E	CURRENT TRANSFORMER		
1	Make		Mehru Electrical & Mechanical Engineers (P) Ltd, Bhiwadi, (Raj), Inida
2	Type and Designation		Outdoor, Oil Cooled Live Tank Type, Current Transformer
3	Applicable standards		IS 16227
4	Class		A
5	Rated Voltage	33 kV	33 kV
6	Rated Primary current	Amps	800-1200-2000A
7	Rated Secondary current	Amps	1
8	Rated output (Burden)	VA	Core:-1 15VA, Core 2: NA, Core;3: 15VA, Core:4: 5VA
9	Rated output at 0.8 lag. p.f.	VA	N/A
10	Class of accuracy		Core:1 - 5P, Core: 2 - PS, Core:-3 & 4: 0.2S
11	Accuracy limit factor		Core1: 10
12	Knee point voltage at all taps	Volts	Core:2: 40(Rct+10)V
13	CT Resistance of secondary winding corrected to 75 deg.C	Ohms	Core-2-2/4/8
14	Magnetising current at knee-voltage point		Core-2-50/40/30mA
15	secondary limiting voltage	kV	As per IS 16227
16	Instrument security factor for winding meant for metering		<=5 at all taps for Core-3&4
17	One minute Power Frequency withstand test voltage of		
a)	Primary winding	kV (rms)	70
b)	Secondary winding	kV (rms)	3
18	1.2/50 Impulse wave withstand voltage of primary winding	kV (peak)	170
19	One minute dry P.F. withstand voltage of primary winding	kV (rms)	70
20	Creepage distance	mm	31mm/kV i.e. 1116mm (Min.)
21	Rated continuous thermal current	Amps	120% of rated primary current
22	Rated short time thermal current	kA (rms)	25 kA
23	Rated time for above	Sec.	1

2. FOR EPC CONTRACTS ONLY

24	Rated dynamic current for primary	kA (Peak)	62.5
25	Class of insulation		A
26	Max. Temperature rise over ambient of 50 deg.C at any part of oil	deg.C	50c max
27			
b)	Radio interference voltage		N/A As per IS 16227 Clause 6.11.2
c)	Partial discharge level		<10 pC at Um & <5 pc at 1.2Um/√3
28	Temp. rise after passing short time thermal current for one second	deg.C	50c max
29	Current density in primary winding at		
a)	Normal rating		1.22 Amp/sqmm
b)	Short time rating of 1 Sec.		12.72 Amp/sqmm(max.)
c)	Dynamic rating		31.8 Amp/sqmm (max.)
30	Type of primary winding		Copper
31	No. of primary turns		1
32	No. of secondary turns		800+400+800
33	Flux density at knee point		1.4 Tesla
34	Radio interference voltage	(micro volts)	
a)	with terminal connector mountd		N/A As per IS 16227 Clause 6.11.2
b)	under test condition		N/A As per IS 16227 Clause 6.11.2
35	Variation in ratio and phase angle error due to variation in		
a)	Voltage by 1%		N/A
b)	Frequency by 1 Hz.		N/A
36	Mounting details		400±5 x 400±5 mm
37	Source/grade of oil and standard with which it complies		EHV Grade Transformer Oil as per IS 335/IEC 60296of any reputed make
38	Quantity of insulating oil	Litres	20 Ltr Approx
39	Weight of Oil	kg	16kgs Approx
40	Total Weight including Oil	kg	135kG Approx
41	Overall dimensions (mm)		1250±75 x 630±50 x 400±5 mm
42	Wheather sealed (if so, type of sealing)		PRD
43 a)	Weight of Steel		65 kgs (Approx.)
c)	Weight of copper		20 kgs (Approx.)