

NOTE: 1. Drawings Approval subject to valid type test reports, to be checked during acceptance tests.

2.For EPC contractors only.

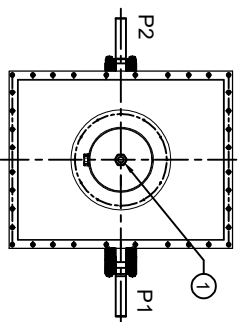

900 ±75

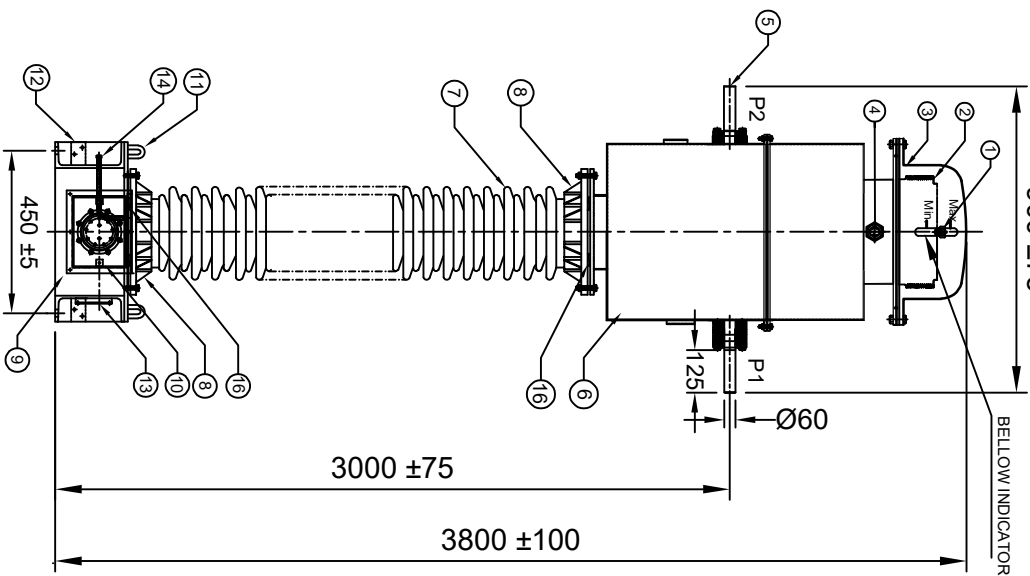

NOTES :-

1. MAKE OF BUSHING: IEC/MODERN/ABIL/BHEL/CJL
 2. ALL FERROUS PARTS EXPOSED TO THE ATMOSPHERE SHALL BE PAINTED WITH P. U. PAINT SHADE 631 OF IS:5
 3. ALL HARDWARE SHALL BE HOT DIP GALVANIZED.
 4. ALL GASKETS SHALL BE FIXED IN PROPERLY MACHINED GROOVES.
 5. ALL GASKETS SHALL BE MADE OF NITRILE BUTYL RUBBER.
 6. TRANSFORMER OIL AS PER IEC : 60296.
 7. PRIMARY WINDING SHALL BE BAR TYPE.
 8. SECONDARY SHALL BE TOTALLY ENCASED IN RIGID METALLIC SHELL.
- * QUANTITY OF OIL :- 225 LITRES APPROX.
 * TOTAL WEIGHT OF CT :- 900 kg. APPROX.
 * TOTAL CREEPAGE DISTANCE:- 6125 mm. MINIMUM

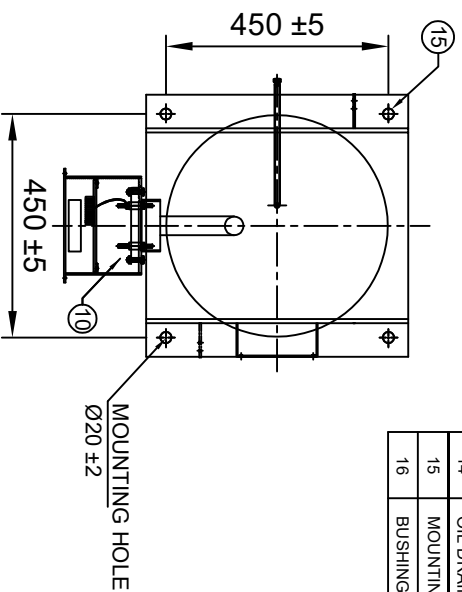
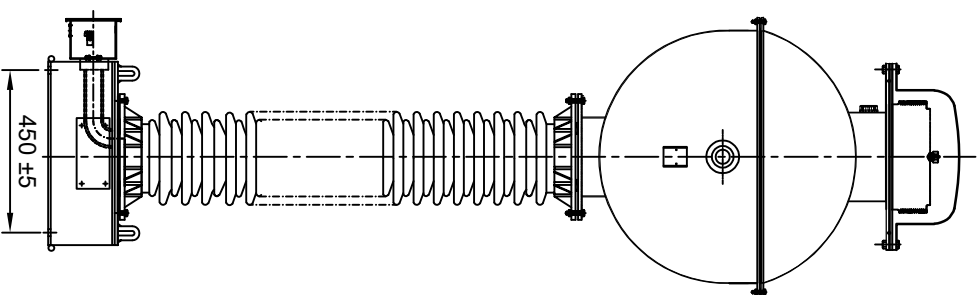

MOUNTING DETAILS

Drawing approval subject to valid vendor registration **APTRANSCO/VS/VIJAYAWADA**
CHIEF ENGINEER/PROJECTS

RATIO : 500-800-1600/1-1-1-A, 300-500-800-1600/1A

UNLESS OTHERWISE SPECIFIED
 1. ALL DIMENSIONS ARE IN mm
 2. TOLERANCE WHEREVER NOT INDICATED: ±5%

S.No.	DESCRIPTION	QTY	MATL
1	OIL FILLING PORT	1	M.S
2	BELLOW	1	S.S
3	BELLOW DOME	1	ALUMINIUM
4	OIL LEVEL INDICATOR	1	AL./BRASS
5	PRIMARY TERMINAL Ø60x125 mm.	2	ALUMINIUM
6	OIL TANK WITH COVER	1	M.S
7	BUSHING	1	PORCELAIN
8	BUSHING FLANGE (CEMENTED)	2	G/I
9	BASE	1	M.S.
10	SECONDARY TERMINAL BOX	1	M.S
11	LIFTING HOOK	4	M.S
12	EARTHING FLAT 80X50X8THICK.	2	M.S
13	NAME AND RATING PLATE	1	AL. ANODIZED
14	OIL DRAIN PLUG	1	M.S
15	MOUNTING HOLES Ø20	4	M.S
16	BUSHING GASKET	2	N.B.R

REV.	REVISION DESCRIPTION	DATED INITIALS
R0	FOR APPROVAL	30.05.2023

UNLESS OTHERWISE SPECIFIED	DATE	NAME	MATERIAL
DOA	30.05.2023	SPS	SEE TABLE
DRN	30.05.2023	K.S	
CHD	30.05.2023	BLS	

TITLE: GENERAL ARRANGEMENT DRAWING FOR 220KV CURRENT TRANSFORMER

SCALE: N.T.S

DRG.NO: ME-220CT-GA-01

MEHRU
 MEHRU ELECTRICAL & MECHANICAL ENGINEERS PVT. LIMITED

NOTE: 1. Drawings Approval subject to valid type test reports, to be checked during acceptance tests.

2. For EPC contractors only.

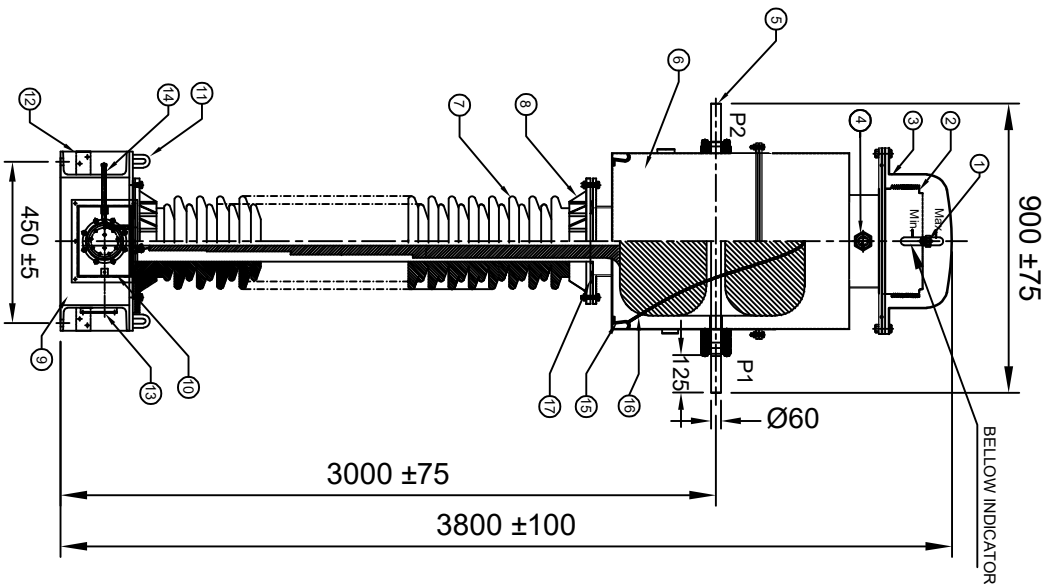
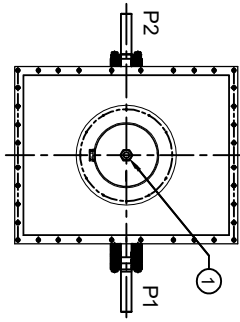

NOTES :-

1. MAKE OF BUSHING: IEC/MODERN/BIJUBHEL/CUI
2. ALL FERROUS PARTS EXPOSED TO THE ATMOSPHERE SHALL BE PAINTED WITH P.U. PAINT SHADE 631 OF IS:5
3. ALL HARDWARE SHALL BE HOT DIP GALVANIZED.
4. ALL GASKETS SHALL BE FIXED IN PROPERLY MACHINED GROOVES.
5. ALL GASKETS SHALL BE MADE OF NITRILE BUTYL RUBBER.
6. TRANSFORMER OIL AS PER IEC : 60296.
7. PRIMARY WINDING SHALL BE BAR TYPE.
8. SECONDARY SHALL BE TOTALLY ENCASED IN RIGID METALLIC SHELL.

- * QUANTITY OF OIL :- 225 LITRES APPROX.
- * TOTAL WEIGHT OF CT :- 900 kg. APPROX.
- * TOTAL CREEPAGE DISTANCE:- 6125 mm. MINIMUM

Drawing approval subject to valid vendor registration

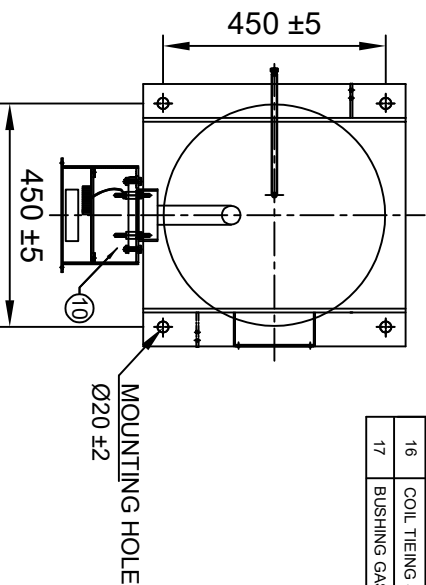
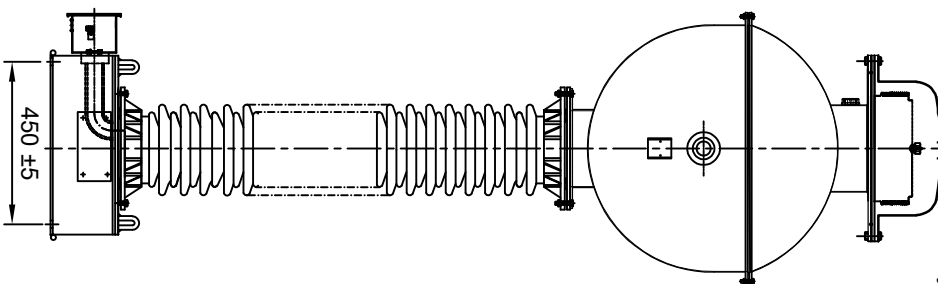

MOUNTING DETAILS

S.No.	DESCRIPTION	QTY	MATL
1	OIL FILLING PORT	1	M.S
2	BELLOW	1	S.S
3	BELLOW DOME	1	ALUMINIUM
4	OIL LEVEL INDICATOR	1	AL./BRASS
5	PRIMARY TERMINAL Ø60x125mm.	2	ALUMINIUM
6	OIL TANK WITH COVER	1	M.S
7	BUSHING	1	PORCELAIN
8	BUSHING FLANGE (CEMENTED)	2	GI/CI
9	BASE	1	M.S.
10	SECONDARY TERMINAL BOX	1	M.S
11	LIFTING HOOK	4	M.S
12	EARTHING FLAT (80x50x8x Thick)	2	M.S
13	NAME AND RATING PLATE	1	ALUMINIUM ANODIZED
14	OIL DRAIN PLUG	1	M.S
15	HOOK FOR COIL TIGHTENING	4	M.S
16	COIL TIEING STRING	--	NYLON
17	BUSHING GASKET	2	NBR

RATIO : 500-800-1600/1-1-1A, 300-500-800-1600/1A

CHIEF ENGINEER/PROJECTS
APTRANSCO/VS/VIJAYAWADA

UNLESS OTHERWISE SPECIFIED		DATE	NAME	MATERIAL
1. ALL DIMENSIONS ARE IN mm	DOA	30.05.2023	S.P.S	
2. TOLERANCE WHEREVER NOT INDICATED: ±5%	DRN	30.05.2023	K.S	SEE TABLE
	CHD	30.05.2023	B.L.S	

REV.	FOR APPROVAL	REVISION DESCRIPTION	DATED INITIALS	TITLE	SCALE	DRG.NO
R0			30.05.2023	SECTIONAL ARRANGEMENT DRAWING FOR 220KV CURRENT TRANSFORMER	N.T.S	ME-220CT-SE-01



MEHRU ELECTRICAL & MECHANICAL ENGINEERS PVT. LIMITED

NOTE: 1. Drawings Approval subject to valid type test reports, to be checked during acceptance tests.

2. For EPC contractors only.



LIVE TANK CURRENT TRANSFORMER

MADE TO IS: 16227

HIGHEST SYSTEM VOLTAGE	245 kV	INSULATION LEVEL	460/1050 kV			
RATED S.T.C	40 kA for 1 sec	RATED FREQUENCY	50 Hz			
NOMINAL SYSTEM VOLTAGE	220 kV	CORE 1	CORE 2	CORE 3	CORE 4	CORE 5
RATIO	PRIMARY (Amp) SECONDARY (Amp)	500-800-1600	500-800-1600	500-800-1600	500-800-1600	300-500-800-1600
SECONDARY TERMINALS	1	1	1	1	1	
RATED BURDEN IN V/A	1S1-1S2-1S3-1S4	2S1-2S2-2S3-2S4	3S1-3S2-3S3-3S4	4S1-4S2-4S3-4S4	5S1-5S2-5S3-5S4	10 VA
ACCURACY CLASS	PX	PX	PX	PX	0.2S	
A.I.F / ISE	---	---	---	---	<5@All Ratio	
Min Knee point voltage	500/800/1600 V	500/800/1600 V	500/800/1600 V	500/800/1600 V	---	
Max Rct at 75 DEG C	2.5/4/8 Ohms	2.5/4/8 Ohms	2.5/4/8 Ohms	2.5/4/8 Ohms	---	
Max Ixct at V _k	80/50/25mA	80/50/25mA	80/50/25mA	80/50/25mA	---	
YEAR OF MANUFACTURE	2023	SERIAL NO.	805025mA	805025mA	---	

RATED CONTINUOUS THERMAL CURRENT 120% OF RATED PRIMARY CURRENT.

* TOTAL WEIGHT OF CT :- 900 kg, APPROX. * QUANTITY OF OIL :- 225 LITRES APPROX. * RATED THERMAL CURRENT: 120%

* TOTAL CREEPAGE DISTANCE :- 6125 mm MINIMUM. * RATED EXTENDED CURRENT: 120%

MADE IN INDIA BY

MEHRU ELECTRICAL AND MECHANICAL ENGINEERS (P) LTD.

SP-2/180, RIICO INDUSTRIAL AREA, KEHRANI, BHIWADI-301019, RAJASTHAN (INDIA)

250 ±20

SUITABLE FOR HOT LINE WASHING

CONNECTION DIAGRAM

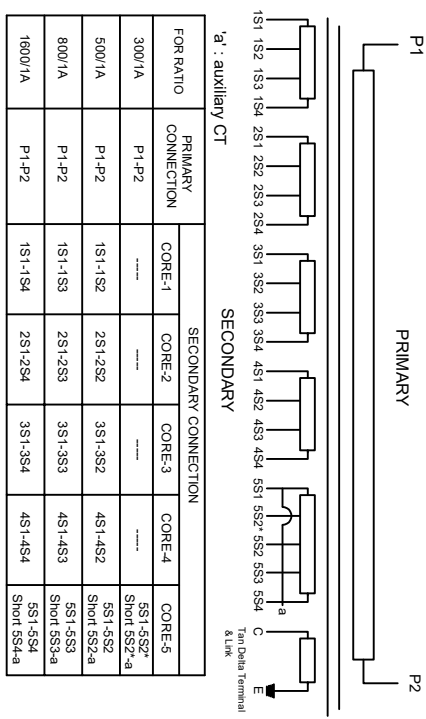

FOR RATIO	PRIMARY CONNECTION	CORE-1	CORE-2	CORE-3	CORE-4	CORE-5
300/1A	P1-P2	---	---	---	---	5S1-5S2- Short 5S2-a
500/1A	P1-P2	1S1-1S2	2S1-2S2	3S1-3S2	4S1-4S2	5S1-5S2- Short 5S2-a
800/1A	P1-P2	1S1-1S3	2S1-2S3	3S1-3S3	4S1-4S3	5S1-5S3- Short 5S3-a
1600/1A	P1-P2	1S1-1S4	2S1-2S4	3S1-3S4	4S1-4S4	5S1-5S4- Short 5S4-a

CAUTION

- I. SHORT CIRCUIT AND EARTH ALL SECONDARY TERMINALS ARE NOT IN USE.
- II. ALWAYS KEEP TAN DELTA TESTING TERMINAL 'C' SHORTED TO EARTH DURING OPERATION.
- III. DO NOT REMOVE EARTH LINK WHEN IN OPERATION.

NOTES:-

1. MATERIAL OF NAME PLATE : ANODIZED ALUMINIUM
2. THICKNESS OF NAME PLATE : 1.2 mm.
3. SERIAL NO. SHALL BE ENGRAVED BEFORE DISPATCH.

1. Minimum 300mm plinth shall be maintained for CT/PT/CVT/Isolators/IV/LA/Breakers in the substation during foundation works to ensure safe live to ground clearance per IE Rules.
2. Since the supply of terminal connectors is not in the scope of manufacturer as mentioned in the drawings. The EPC contractor shall be instructed to supply the same line with CT/PT/CVT/Isolator/IV/LA/Breaker's requirement and compatibility.

Drawing approval subject to valid vendor registration

RATIO : 500-800-1600/1-1-1-1A, 300-500-800-1600/1A

CHIEF ENGINEER/PROJECTS
APTRANSCO/VS/VIJAYAWADA

FOR APPROVAL	30.05.2023
REVISION DESCRIPTION	DATED INITIALS

UNLESS OTHERWISE SPECIFIED	DATE	NAME	MATERIAL
1. ALL DIMENSIONS ARE IN mm	DGN. 30.05.2023	SPS	AL. ANODIZED
2. TOLERANCE WHEREVER NOT INDICATED: ±5%	DRN. 30.05.2023	K.S	
	CHD. 30.05.2023	BLS	
TITLE			
NAME PLATE DRAWING FOR 220KV CURRENT TRANSFORMER			
SCALE			N T S
DRG.NO			ME-220CT-NP-01



MEHRU ELECTRICAL & MECHANICAL ENGINEERS PVT. LIMITED

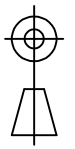

NOTE: 1. Drawings Approval subject to valid type test reports, to be checked during

acceptance tests.

2. For EPC contractors only.

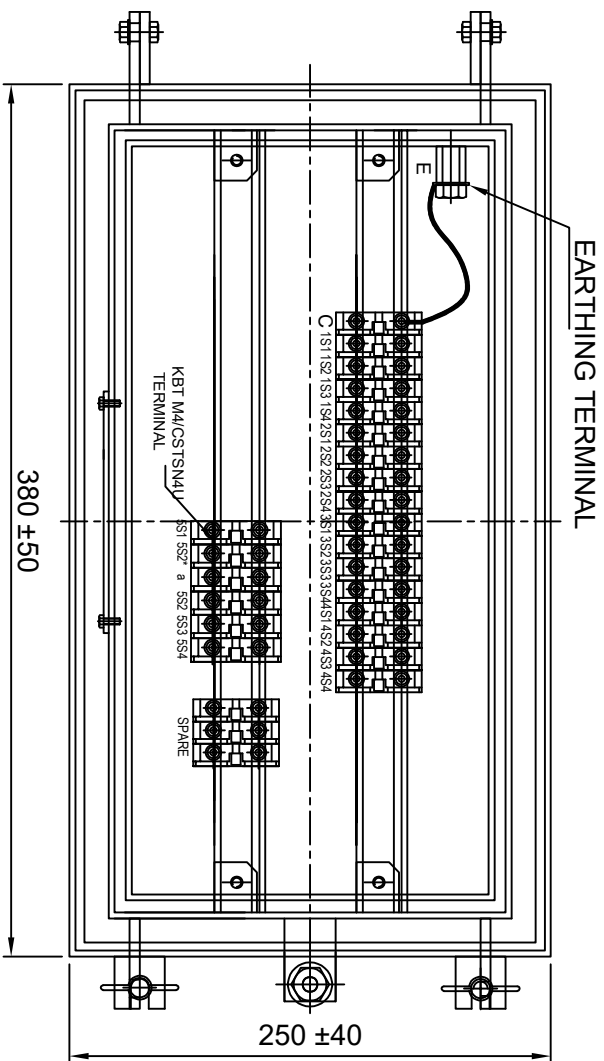

FRONT VIEW

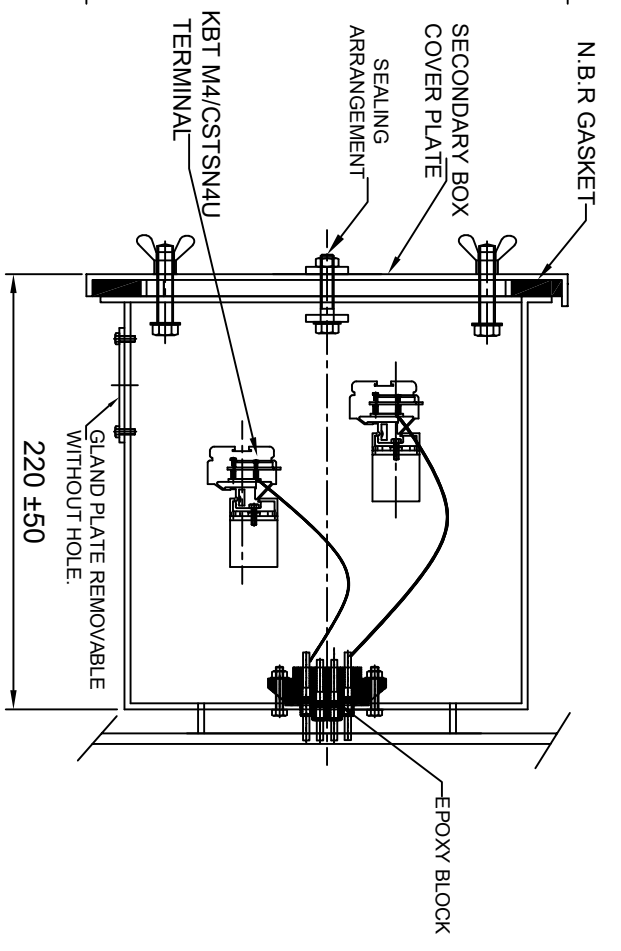

SIDE VIEW

KBT M4/CSTSN4U
TERMINAL

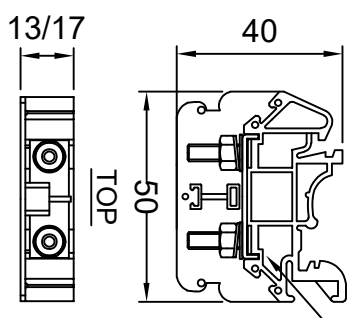

FRONT

SIDE

MATERIAL : POLYAMIDE
MAKE : ELEMEX/CONNECTWELL
TERMINAL (DETAIL)

NOTES:-

1. SECONDARY TERMINAL BOX SHALL BE PROVIDED WITH REMOVABLE GLAND PLATE WITHOUT HOLE.
2. SECONDARY TERMINAL BOX SHALL BE PROVIDED WITH COVER.
3. SHEET THICKNESS FOR TERMINAL BOX SHALL BE 3.0mm & FOR COVER 2.0mm.
4. MATERIAL OF GASKET : NITRILE BUTYL RUBBER GASKET.
5. DEGREE OF PROTECTION : IP 55
6. 20% SPARE TERMINAL SHALL BE PROVIDED.

'C' : TAN DELTA TESTING TERMINAL
'E' : EARTHING TERMINAL
'a' : AUXILIARY CT

CHIEF ENGINEER/PROJECTS
APTRANSCO/VS/VIJAYAWADA

RATIO : 500-800-1600/1-1-1-1A, 300-500-800-1600/1A

UNLESS OTHERWISE SPECIFIED
1. ALL DIMENSIONS ARE IN mm
2. TOLERANCE WHEREVER NOT INDICATED: ±5%

DATE	NAME	MATERIAL
30.05.2023	SPS	M/S
30.05.2023	K.S	
30.05.2023	B.S	

MEHRU
MEHRU ELECTRICAL & MECHANICAL
ENGINEERS PVT. LIMITED

REV.	REVISION DESCRIPTION	DATED INITIALS
R0	FOR APPROVAL	30.05.2023

TITLE
SECONDARY TERMINAL BOX DRG.
FOR 220KV CURRENT TRANSFORMER

SCALE
N.T.S
DRG.NO
ME-220CT-STB-01

Drawing approval subject to valid vendor registration

NOTE: 1. Drawings Approval subject to valid type test reports, to be checked during acceptance tests.

2. For EPC contractors only.

Guaranteed Technical Particulars for 220kV Current Transformer			
Sl. No.	Item Description	Unit	
E	CURRENT TRANSFORMER		
1	Make		Mehru Electrical & Mechanical Engineers (P) Ltd, Bhiwadi, (Raj), Inida
2	Type and Designation		Outdoor, Oil Cooled Live Tank Type, Current Transformer
3	Applicable standards		IS 16227
4	Class		A
5	Rated Voltage	220 kV	220 kV
6	Rated Primary current	Amps	500-800-1600A,300-500-800-1600A
7	Rated Secondary current	Amps	1
8	Rated output (Burden)	VA	Core:-5: 10VA,
9	Rated output at 0.8 lag. p.f.	VA	N/A
10	Class of accuracy		Core:1,2,3 & 4 - PX, Core:-5: 0.2S
11	Accuracy limit factor		NA
12	Knee point voltage	Volts	Core-1,2,3&4-500-800-1600
13	CT Resistance of secondary winding corrected to 75 deg.C	Ohms	Core-1,2,3&4-2.5/4/8
14	Magnetising current at knee-voltage point		Core-1,2,3&4-80/50/25mA
15	Secondary limiting voltage	kV	As per IS 16227
16	Instrument security factor for winding meant for metering		Core-5 ≤ 5@all ratio
17	One minute Power Frequency withstand test voltage of		
a	Primary winding	kV (rms)	460
b	Secondary winding	kV (rms)	3
18	1.2/50Hz Impulse wave withstand voltage of primary winding	kV (peak)	1050
19	One minute dry P.F. withstand voltage of primary winding	kV (rms)	460
20	Creepage distance	mm	25mm/kV i.e. 6125mm (Min.)
21	Rated continuous thermal current	Amps	120% of rated primary current
22	Ratios available at highest taps		Yes
23	Rated short time thermal current	kA (rms)	40 kA
24	Rated time for above	Sec.	1
25	Rated dynamic current for primary	kA (Peak)	100
26	Class of insulation		A
27	Max. Temperature rise over ambient of 50 deg.C at any part of oil	deg.C	50c max
28			
a)	Radio interference voltage		As per IS 16627 Clause -6.11.2<2500uV
b)	Partial discharge level		<10 pC at Um & <5 pc at 1.2 Um/√3
29	Temp. rise after passing short time thermal current for one second	deg.C	50c max
30	Current density in primary winding at		
a)	Normal rating		0.56 Amp/sqmm
b)	Short time rating of 1 Sec.		14.15 Amp/sqmm
c)	Dynamic rating		35.5 Amp/sqmm
31	Type of primary winding		Aluminum
32	No. of primary turns		1
33	Type of secondary winding		Copper

Drawing approval subject to valid vendor registration

**CHIEF ENGINEER/PROJECTS
APTRANSCO/VS/VIJAYAWADA**

NOTE: 1. Drawings Approval subject to valid type test reports, to be checked during acceptance tests.

2. For EPC contractors only

34	Radio interference voltage	(micro volts)	
a)	with terminal connector mounted		<2500uV
b)	under test condition		<2500uV
35	Mounting details		450±5 x 450±5 mm
36	Source/grade of oil and standard with which it complies		EHV Grade Transformer Oil as per IS 335 /IEC 60296 of any reputed make
37	Quantity of insulating oil	Litres	225 Ltr Approx
38	Weight of Oil	kg	180 Kgs Approx
39	Total Weight including Oil	kg	900kG Approx
40	Overall dimensions (mm)		3800±100 x 900±75 x 450±5 mm
41	Weather sealed (if so, type of sealing)		Yes, By SS BELLOW
42	Tan delta		<0.005
43	Height of supporting structure		Not in our scope of supply
44	Whether the following are enclosed with the tender		
a)	All type test reports		Yes
b)	Drawings as per the specification		Yes
c)	Technical literature for C.T.		Yes

1. Minimum 300mm plinth shall be maintained for CT/PT/CVT/Isolators/IV/LA/Breakers in the substation during foundation works to ensure safe live to ground clearance per IE rules.
2. Since the supply of terminal connectors is not in the scope of manufacturer as mentioned in the drawings. The EPC contractor shall be instructed to supply the same line with CT/PT/CVT/Isolator/IVT/LA/Breaker's requirement and compatibility.

**CHIEF ENGINEER/PROJECTS
APTRANSCO/VS/VIJAYAWADA**

Drawing approval subject to valid vendor registration