

**FOR EPC CONTRACTS ONLY**

NOTE : DRAWING APPROVAL SUBJECT TO VALID TYPE TEST REPORTS, TO BE CHECKED DURING ACCEPTANCE TESTS.

ANNEXURE-II (SURGE ARRESTERS)**GUARANTEED TECHNICAL PARTICULARS FOR 216KV 10KA TYPE-SM METAL OXIDE GAPLESS PORCELAIN LIGHTNING ARRESTER**

- | | | |
|--|---------------|--|
| 1. Name of Manufacturer | : | LAMCO INDUSTRIES PRIVATE LIMITED.,
H.O & WORKS: SANATHNAGAR-IE, HYD
WORKS: AUTOMOTIVE PARK, TSIIC,
MUPPIREDDYPALLY, T.S, INDIA. |
| 2. Arrester class & type | : | Medium Duty Station Class Metal Oxide
Gapless Lightning Arrester "MORESTER"
Type-SM, MODEL-'LMAS' |
| 3. Applicable standard | : | IEC 60099-4 of 2014 |
| 4. Rated arrester voltage | | KV : 216 |
| 5. Max. con. operating voltage MCOV | | KV : 184
Drawing approval subject to valid vendor registration |
| 6. Nominal discharge current with
8/20 micro seconds wave | | KA : 10 |
| 7. Long duration discharge Class | | : 3 (STATION MEDIUM) |
| 8. Thermal Energy Rating | "kJ/kV of Ur" | : 7 |
| 9. Max. switching current impulse
residual voltage at | | |
| i) 1000 A | | kVpeak : 494 |
| 10. Max. residual voltage with 1 micro
second current wave at 10KA | | KVPeak : 654 |
| 11. Max. residual voltage with 8/20 mic.
sec.wave | | |
| i) 5 KA | | KVpeak : 567 |
| ii) 10 KA | | KVpeak : 602 |
| iii) 20 KA | | KVpeak : 668 |
| 12. Safe fault current | | KArms : 40 @ 0.2Sec |
| 13. Lightning impulse withstand voltage of
arrester housing with 1.2/50 us wave | | KVpeak: 1050 |
| 14. One minute power frequency withstand
voltage of housing dry-wet | | KVrms : 460 |
| 15. Repetitive Charge Transfer Rating | Qrs | : 1.6C |

Continued on page...2

Chief Engineer
Projects

::2::

16. High current short duration impulse
withstand level with 4/10 us wave KApeak : 100
17. Pressure relief class Class : A (40 kA)
18. Over-voltage withstand capability (with prior duty)
a) 10 seconds KVP : 367
b) 1 second KVP : 385
c) 0.1 second KVP : 397
19. a) Reference voltage KV : Greater than the rated
Arrester voltage at 3mA
reference current
b) Reference current mA : 3
20. Number of units per phase and : 3
Rating of each unit KV : 72
21. Min.total creepage distance mm : 6150
22. Leakage current mA : Less than 0.8
23. Total (approx) weight of arrester Kgs : 170 ±10%
24. Maximum cantilever strength of SA
(Including wind load) Kg : 1000
25. Overall Height of SA mm : 2760±107 minimum
26. Maximum distance recommended from
equipment to be protected by SA mtr : 25
27. Min.distance between phase and
grounded object mm : 2900
28. Min. distance between arrester
phase legs mm : 3400
29. R.I.V @ 1.1 COV : less than 2500µV.
30. Make of porcelain Insulators : CJI,RAVIKIRAN,GENESIS or any
other reputed manufacturer
31. Partial Discharge @ 1.05 C.O.V : Less than 10pC
32. Seismic Acceleration : 0.3g
Horizontal + Vertical
33. Cantilever strength : 150kg (deflection 20mm)

for **LAMCO INDUSTRIES PRIVATE LIMITED.**

(K. ARUN)
SENIOR MANAGER (D&D)

Drawing approval subject to valid vendor registration

Chief Engineer
Projects

This drawing and design is the property of MEIL and must not be copied or lent without prior permission in writing

1) Minimum 300mm plinth shall be maintained for CT/PT/CVT/Isolators in the substation during foundation works to ensure safe live to ground clearances as per IE rules.

2) Since the supply of terminal connectors is not in the scope of manufacturer as mentioned in the drawings, the EPC contractors shall be instructed to supply the same in line with CT/PT/CVT/Isolators requirement and compatibility.

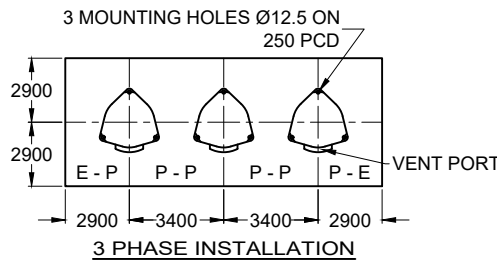
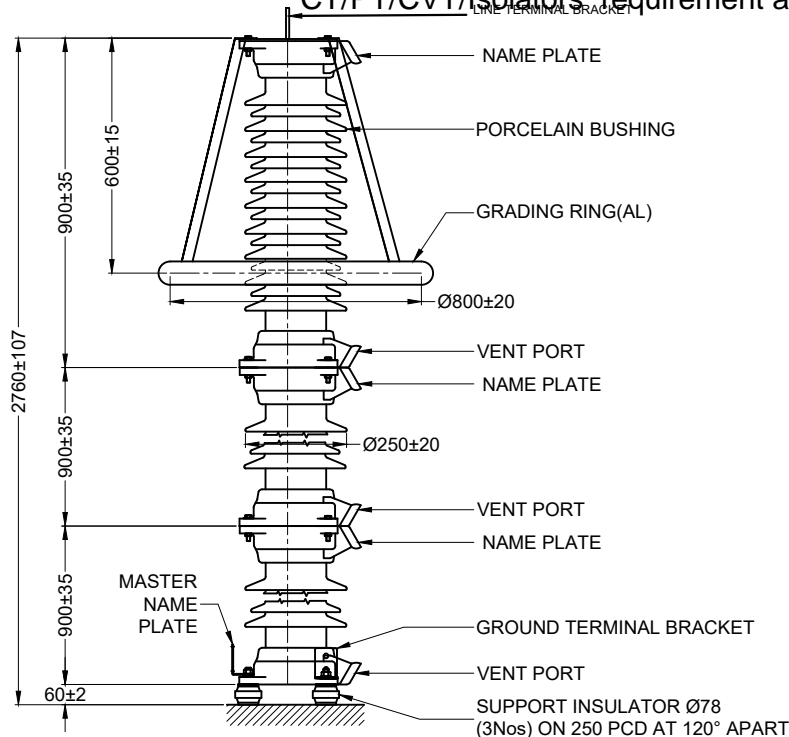

- NOTE :
1. FOR SURGE MONITOR REFER Drg.No. : 4249001A.
 2. FOR INSTALLATION AND INTERCONNECTION REFER Drg. No. : 4320010.
 3. TOTAL CREEPAGE DISTANCE 6150 mm (NOM).
 4. ARRESTER VENT PORTS SHOULD BE DIRECTED TOWARDS SAFE DIRECTION.
 5. WEIGHT OF THE ARRESTER : 170±10% Kgs.

Chief Engineer
Projects

00	FIRST SUBMISSION	24.05.2023	K.B	K.A	K.A	K.A
REV.No.	DESCRIPTION	DATE	DRAWN	CHECKED	APPD.	STATUS
OWNER:		TRANSMISSION CORPORATION OF ANDHRA PRADESH LIMITED				
CONTRACTOR:		AS APPLICABLE				
PROJECT:		AS APPLICABLE				
L.O.I No.:		AS APPLICABLE				
TITLE:		216kV, 10kA LIGHTNING ARRESTER (MORESTER TYPE-SM, MODEL- LMAS)				
DRAWING No.		SIZE	SCALE	TOTAL SHEETS	SH.No.	REV.
MEIL-APT-1239-GDV-S- 2212167		A2	NTS	01	01of01	00

Drawing approval subject to valid vendor registration

This drawing and design is the property of MEIL and must not be copied or lent without prior permission in writing

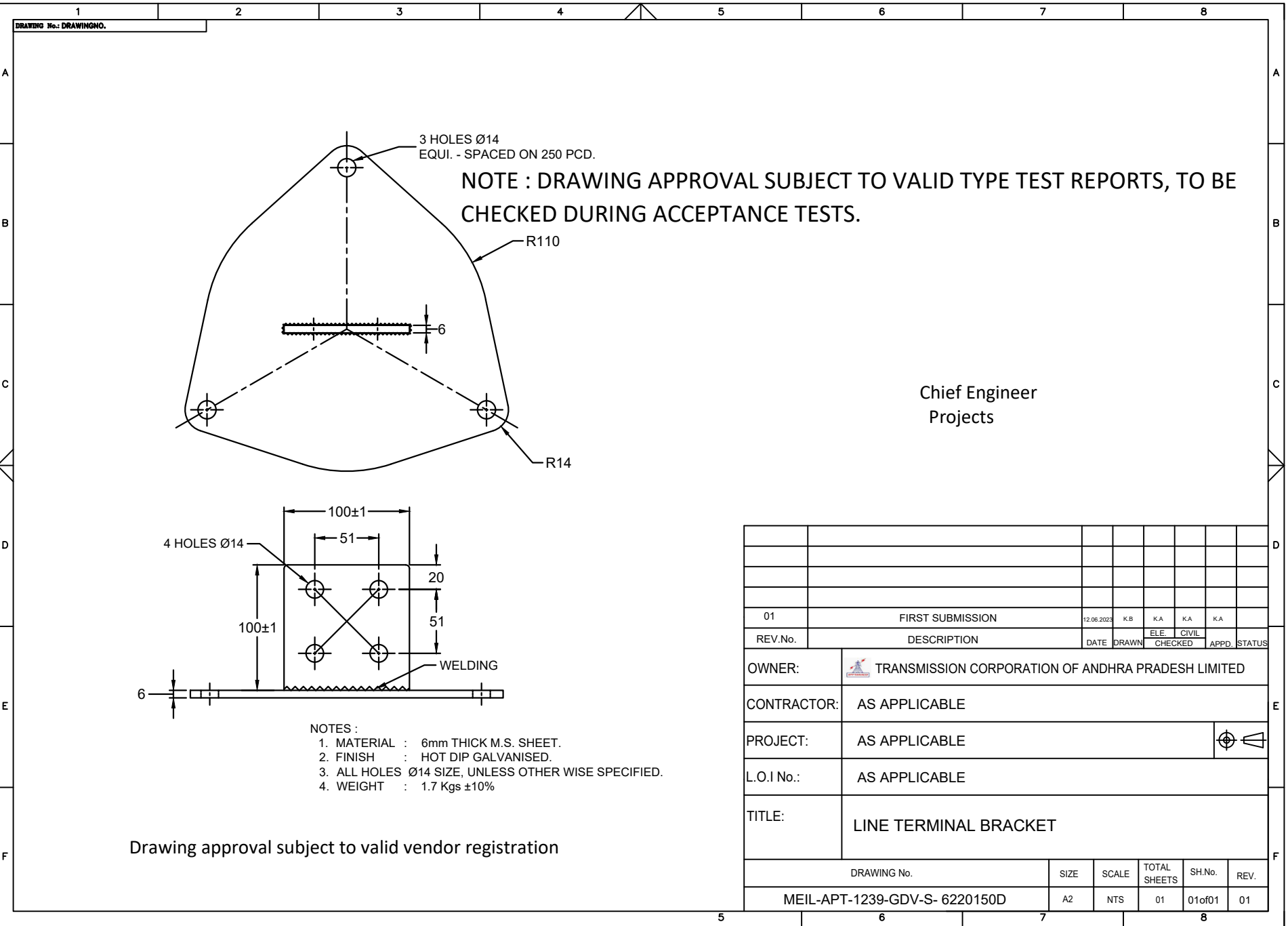

NOTE : DRAWING APPROVAL SUBJECT TO VALID TYPE TEST REPORTS, TO BE CHECKED DURING ACCEPTANCE TESTS.

Chief Engineer
Projects

- NOTES :
1. MATERIAL : 6mm THICK M.S. SHEET.
 2. FINISH : HOT DIP GALVANISED.
 3. ALL HOLES Ø14 SIZE, UNLESS OTHER WISE SPECIFIED.
 4. WEIGHT : 1.7 Kgs ±10%

Drawing approval subject to valid vendor registration

01	FIRST SUBMISSION	12.06.2023	K.B	K.A	K.A	K.A	
REV.No.	DESCRIPTION	DATE	DRAWN	CHECKED	APPD.	STATUS	
OWNER: TRANSMISSION CORPORATION OF ANDHRA PRADESH LIMITED							
CONTRACTOR: AS APPLICABLE							
PROJECT: AS APPLICABLE							
L.O.I No.: AS APPLICABLE							
TITLE: LINE TERMINAL BRACKET							
DRAWING No.		SIZE	SCALE	TOTAL SHEETS	SH.No.	REV.	
MEIL-APT-1239-GDV-S- 6220150D		A2	NTS	01	01of01	01	

This drawing and design is the property of MEIL and must not be copied or lent without prior permission in writing

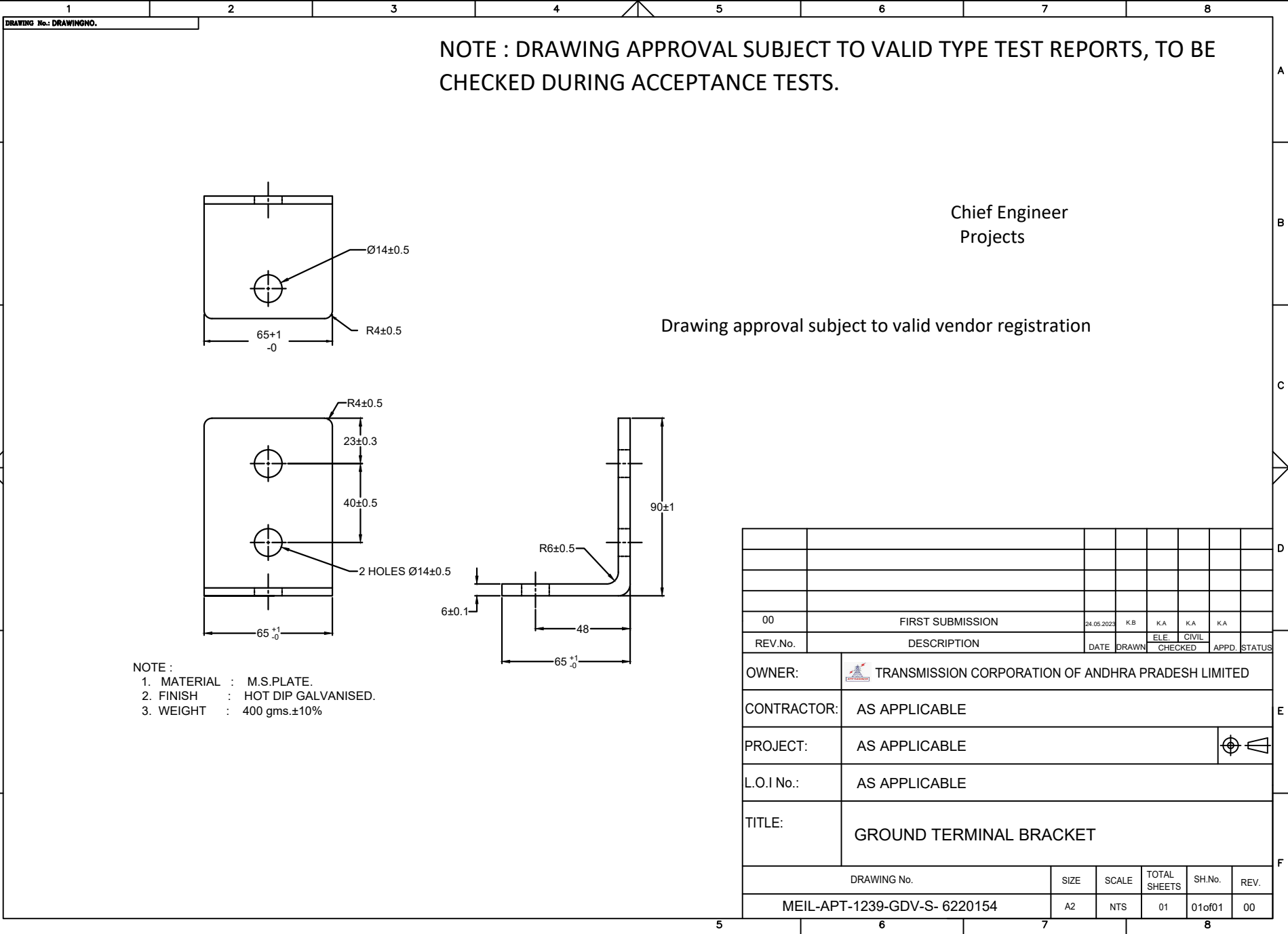

00	FIRST SUBMISSION	24.05.2023	K.B	K.A	K.A	K.A
REV.No.	DESCRIPTION	DATE	DRAWN	ELE. CHECKED	CIVIL	APPD. STATUS
OWNER:		TRANSMISSION CORPORATION OF ANDHRA PRADESH LIMITED				
CONTRACTOR:		AS APPLICABLE				
PROJECT:		AS APPLICABLE				
L.O.I No.:		AS APPLICABLE				
TITLE:		GROUND TERMINAL BRACKET				
DRAWING No.		SIZE	SCALE	TOTAL SHEETS	SH.No.	REV.
MEIL-APT-1239-GDV-S- 6220154		A2	NTS	01	01of01	00

DRAWING No.: DRAWINGNO.

NOTE : DRAWING APPROVAL SUBJECT TO VALID TYPE TEST REPORTS, TO BE CHECKED DURING ACCEPTANCE TESTS.

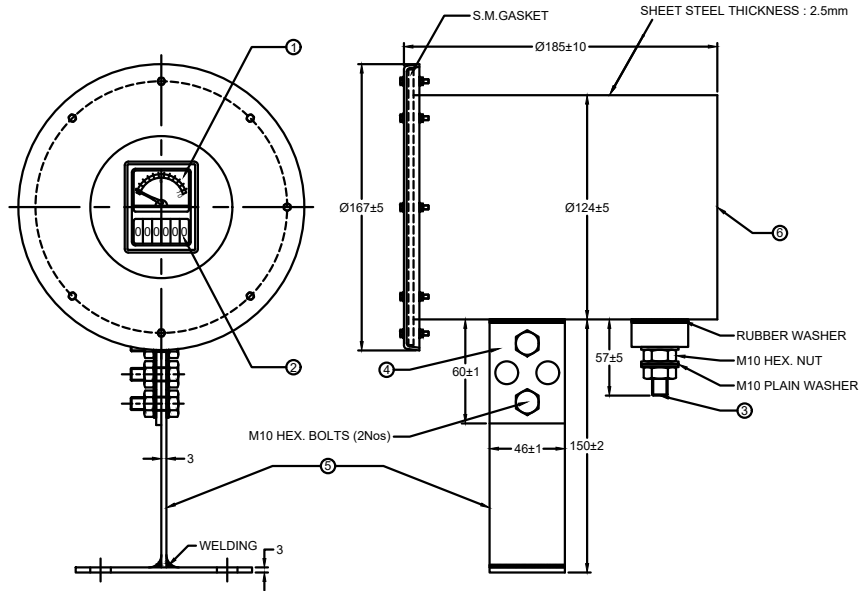

Chief Engineer
Projects

Drawing approval subject to valid vendor registration

1. LEAKAGE CURRENT MONITOR.
2. SURGE COUNTER, CYCLOMETRIC TYPE.
3. LINE TERMINAL.
4. S.M. - STRIP (EARTH TERMINAL), 3mmTHICK
5. S.M. - MOUNTING BRACKET. 3mmTHICK - MS(HDG)
6. S.M. - BOX.
7. MATERIAL- M.S HOT DIP GALVANISED
8. MAKE : LAMCO MAKE
9. RANGE OF LEAKAGE CURRENT METER(0-10mA)
 - a) 0 - 6mA (HEALTHY) GREEN ZONE
 - b) 6 - 10mA (DANGER) RED ZONE

NOTE :

- * DEGREE OF PROTECTION : IP - 67
- * SEALANT APPLIED AT GASKETS
- * STANDARD : IS / IEC 60947-1 : 2004
- * GASKET DETAILS:
 MATERIAL : NEOPRENE RUBBER.
 SIZE : OD-161mm, ID-125mm, Thick-5mm.
 CROSS SECTION VIEW OF GASKET Ref. Drg. No.4250002
 WEIGHT : 2.8Kgs ± 10%.

00	FIRST SUBMISSION	24.05.2023	KB	KA	KA	KA
REV.No.	DESCRIPTION	DATE	DRAWN	CHECKED	APPD.	STATUS
OWNER:	TRANSMISSION CORPORATION OF ANDHRA PRADESH LIMITED					
CONTRACTOR:	AS APPLICABLE					
PROJECT:	AS APPLICABLE					
L.O.I No.:	AS APPLICABLE					
TITLE:	SURGE MONITOR G.A.					
DRAWING No.		SIZE	SCALE	TOTAL SHEETS	SH.No.	REV.
MEIL-APT-1239-GDV-S- 4249001A		A2	NTS	01	01of01	00

This drawing and design is the property of MEIL and must not be copied or lent without prior permission in writing

This drawing and design is the property of MEIL and must not be copied or lent without prior permission in writing

- 1) Minimum 300mm plinth shall be maintained for CT/PT/CVT/Isolators in the substation during foundation works to ensure safe live to ground clearances as per IE rules.
- 2) Since the supply of terminal connectors is not in the scope of manufacturer as mentioned in the drawings, the EPC contractors shall be instructed to supply the same in line with CT/PT/CVT/Isolators requirement and compatibility.

NOTE : DRAWING APPROVAL SUBJECT TO VALID TYPE TEST REPORTS, TO BE CHECKED DURING ACCEPTANCE TESTS.

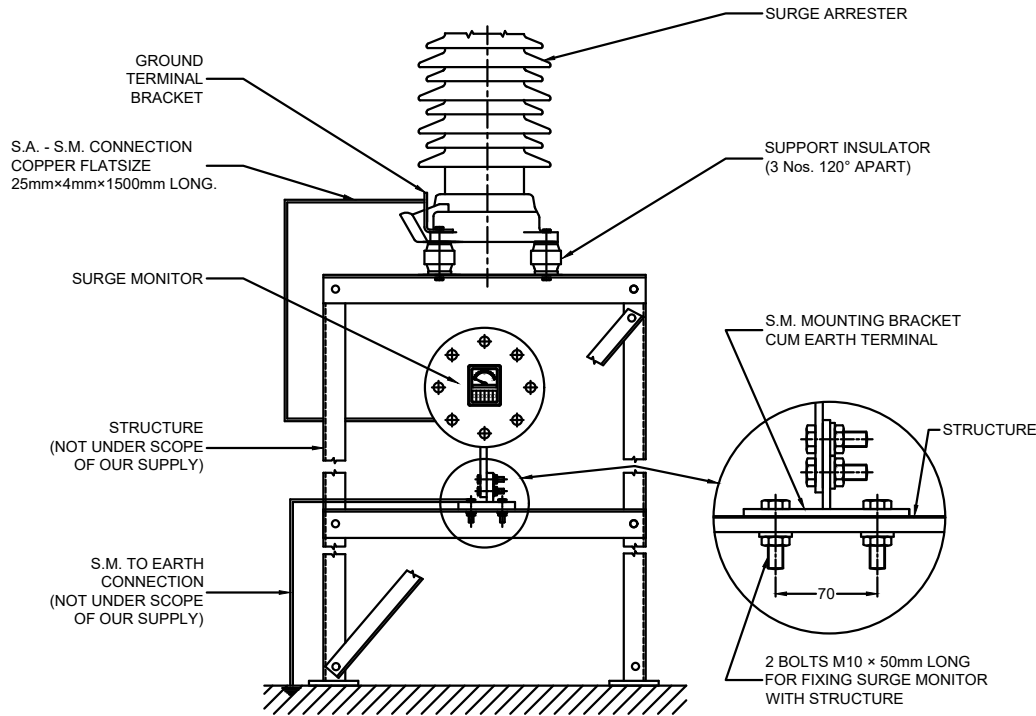

Chief Engineer
Projects

Drawing approval subject to valid vendor registration

00	FIRST SUBMISSION	24.05.2023	K.B	K.A	K.A	K.A	
REV.No.	DESCRIPTION	DATE	DRAWN	ELE. CHECKED	CIVIL	APPD.	STATUS
OWNER:		TRANSMISSION CORPORATION OF ANDHRA PRADESH LIMITED					
CONTRACTOR:		AS APPLICABLE					
PROJECT:		AS APPLICABLE					
L.O.I No.:		AS APPLICABLE					
TITLE:		METHOD OF CONNECTING SURGE MONITOR WITH SURGE ARRESTER					
DRAWING No.		SIZE	SCALE	TOTAL SHEETS	SH.No.	REV.	
MEIL-APT-1239-GDV-S- 4320010		A2	NTS	01	01of01	00	

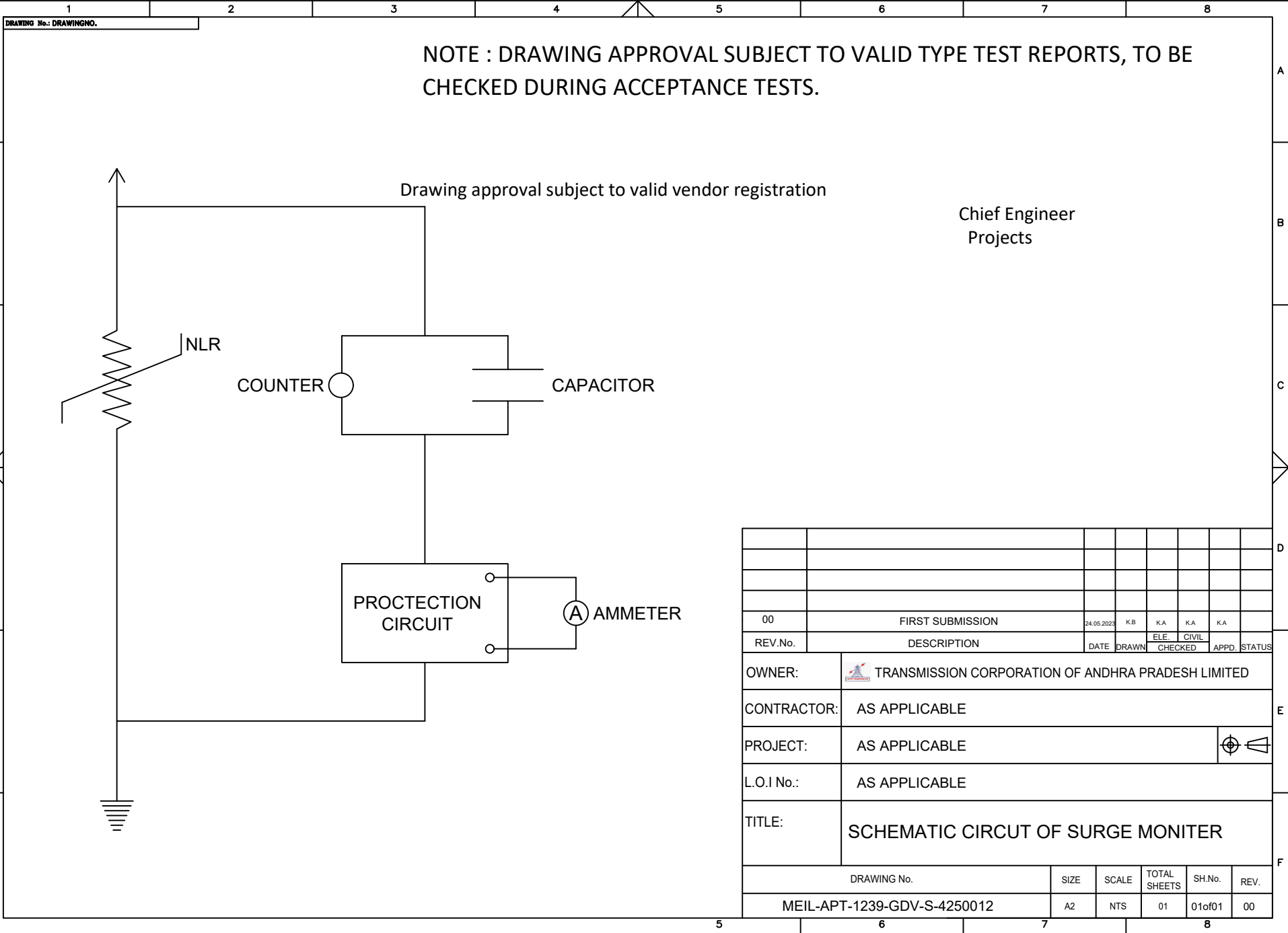

This drawing and design is the property of MEIL and must not be copied or lent without prior permission in writing



NOTE : DRAWING APPROVAL SUBJECT TO VALID TYPE TEST REPORTS, TO BE CHECKED DURING ACCEPTANCE TESTS.

Drawing approval subject to valid vendor registration

Chief Engineer
Projects

00	FIRST SUBMISSION	24.05.2023	KB	K.A	K.A	K.A			
REV.No.	DESCRIPTION	DATE	DRAWN	CHECKED	APPD.	STATUS			
OWNER:	 TRANSMISSION CORPORATION OF ANDHRA PRADESH LIMITED								
CONTRACTOR:	AS APPLICABLE								
PROJECT:	AS APPLICABLE 								
L.O.I No.:	AS APPLICABLE								
TITLE:	SCHEMATIC CIRCUIT OF SURGE MONITER								
DRAWING No.		SIZE	SCALE	TOTAL SHEETS	SH.No.	REV.			
MEIL-APT-1239-GDV-S-4250012		A2	NTS	01	01of01	00			

DRAWING No.: DRAWINGNO.

NOTE : DRAWING APPROVAL SUBJECT TO VALID TYPE TEST REPORTS, TO BE CHECKED DURING ACCEPTANCE TESTS.

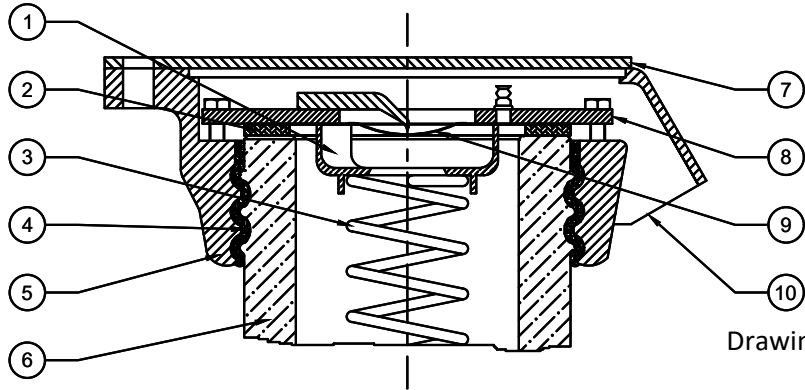

Chief Engineer
Projects

Drawing approval subject to valid vendor registration

This drawing and design is the property of MEIL and must not be copied or lent without prior permission in writing

S.No.	ITEM	MATERIAL
1.	SP. SUPPORT.	ALUMINIUM
2.	RUBBER GASKET.	NEOPRENE ,5mm THICK
3.	SPRING.	SPRING STEEL
4.	SULPHUR CEMENT.	SULPHUR CEMENT
5.	CASTING.	ALUMINIUM (LM-6)
6.	BUSHING.	PORCELAIN
7.	END COVER PLATE.	ALUMINIUM
8.	COVER PLATE.	M.S (HOT DIP GALVANIZED)
9.	PRESSURE RELIEF DIAPHRAGM.	BRASS
10.	VENT PORT.	ALUMINIUM

00	FIRST SUBMISSION	24.05.2023	K.B	KA	KA	KA	
REV.No.	DESCRIPTION	DATE	DRAWN	ELE. CHECKED	CIVIL	APPD.	STATUS
	OWNER:	TRANSMISSION CORPORATION OF ANDHRA PRADESH LIMITED					
	CONTRACTOR:	AS APPLICABLE					
	PROJECT:	AS APPLICABLE					
	L.O.I No.:	AS APPLICABLE					
	TITLE:	PRESSURE RELIEF AND SEALING ARRANGEMENT OF MORESTER					
	DRAWING No.	SIZE	SCALE	TOTAL SHEETS	SH.No.	REV.	
	MEIL-APT-1239-GDV-S- 4220041	A2	NTS	01	01of01	00	

This drawing and design is the property of MEIL and must not be copied or lent without prior permission in writing

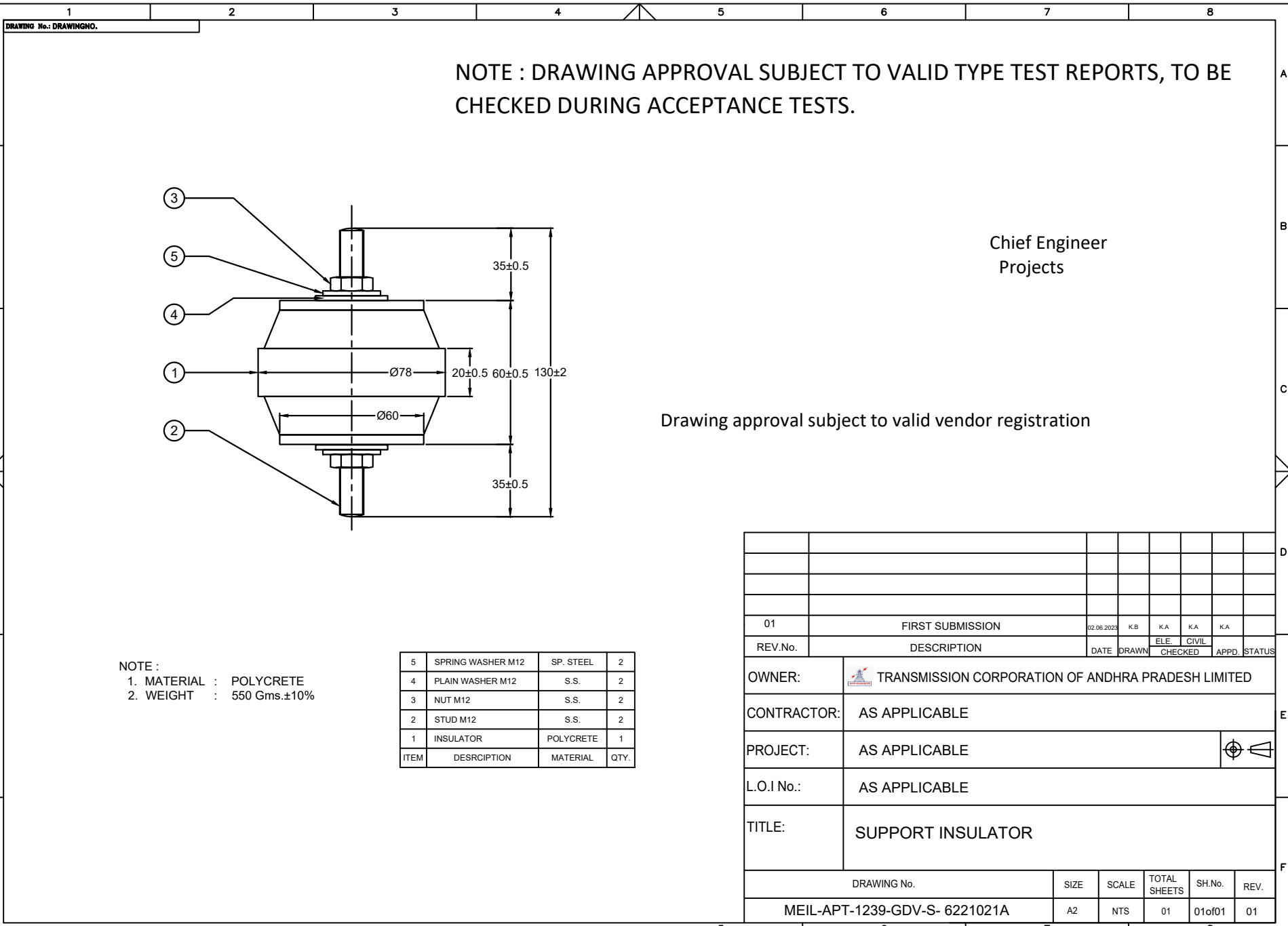

NOTE : DRAWING APPROVAL SUBJECT TO VALID TYPE TEST REPORTS, TO BE CHECKED DURING ACCEPTANCE TESTS.

Chief Engineer
Projects

Drawing approval subject to valid vendor registration

NOTE :
1. MATERIAL : POLYCRETE
2. WEIGHT : 550 Gms.±10%

ITEM	DESCRIPTION	MATERIAL	QTY.
5	SPRING WASHER M12	SP. STEEL	2
4	PLAIN WASHER M12	S.S.	2
3	NUT M12	S.S.	2
2	STUD M12	S.S.	2
1	INSULATOR	POLYCRETE	1







REV.No.	DESCRIPTION	DATE	DRAWN	CHECKED	APPD.	STATUS
01	FIRST SUBMISSION	02.06.2023	K.B	KA	KA	KA

OWNER:	TRANSMISSION CORPORATION OF ANDHRA PRADESH LIMITED				
CONTRACTOR:	AS APPLICABLE				
PROJECT:	AS APPLICABLE				
L.O.I No.:	AS APPLICABLE				
TITLE:	SUPPORT INSULATOR				

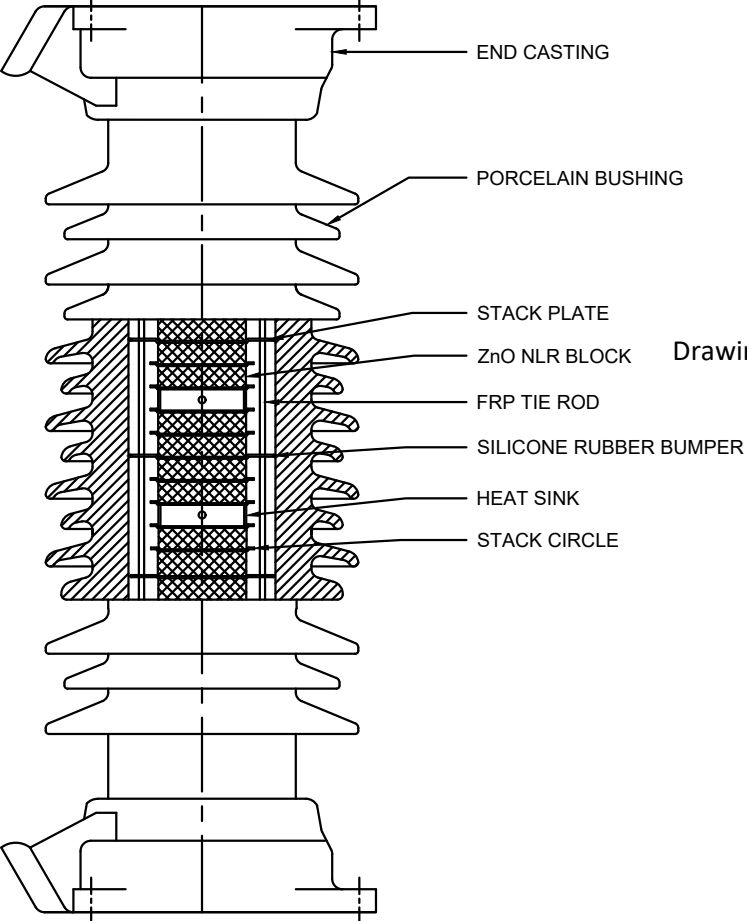
DRAWING No.	SIZE	SCALE	TOTAL SHEETS	SH.No.	REV.
MEIL-APT-1239-GDV-S- 6221021A	A2	NTS	01	01of01	01

1 2 3 4 5 6 7 8

A B C D E F

1	2	3	4	5	6	7	8																																																																						
DRAWING No.: DRAWINGNO.		NOTE : DRAWING APPROVAL SUBJECT TO VALID TYPE TEST REPORTS, TO BE CHECKED DURING ACCEPTANCE TESTS.																																																																											
A							A																																																																						
B	Chief Engineer Projects						B																																																																						
C	Drawing approval subject to valid vendor registration						C																																																																						
D	<table border="1" style="width: 100%; border-collapse: collapse;"> <tr> <td style="width: 5%;"> </td> <td style="width: 15%;"> </td> <td style="width: 15%;"> </td> <td style="width: 15%;"> </td> <td style="width: 15%;"> </td> <td style="width: 15%;"> </td> <td style="width: 15%;"> </td> </tr> <tr> <td style="text-align: center;">00</td> <td style="text-align: center;">FIRST SUBMISSION</td> <td style="text-align: center;">24.05.2023</td> <td style="text-align: center;">K.B</td> <td style="text-align: center;">K.A</td> <td style="text-align: center;">K.A</td> <td style="text-align: center;">K.A</td> </tr> <tr> <td style="text-align: center;">REV.No.</td> <td style="text-align: center;">DESCRIPTION</td> <td style="text-align: center;">DATE</td> <td style="text-align: center;">DRAWN</td> <td style="text-align: center;">ELE. CHECKED</td> <td style="text-align: center;">CIVIL CHECKED</td> <td style="text-align: center;">APPD. STATUS</td> </tr> <tr> <td colspan="2">OWNER:</td> <td colspan="5">  TRANSMISSION CORPORATION OF ANDHRA PRADESH LIMITED </td> </tr> <tr> <td colspan="2">CONTRACTOR:</td> <td colspan="5">AS APPLICABLE</td> </tr> <tr> <td colspan="2">PROJECT:</td> <td colspan="5">AS APPLICABLE</td> </tr> <tr> <td colspan="2">L.O.I No.:</td> <td colspan="5">AS APPLICABLE</td> </tr> <tr> <td colspan="2">TITLE:</td> <td colspan="5" style="text-align: center;">SECTIONAL VIEW OF MORESTER</td> </tr> <tr> <td colspan="2">DRAWING No.</td> <td style="text-align: center;">SIZE</td> <td style="text-align: center;">SCALE</td> <td style="text-align: center;">TOTAL SHEETS</td> <td style="text-align: center;">SH.No.</td> <td style="text-align: center;">REV.</td> </tr> <tr> <td colspan="2">MEIL-APT-1239-GDV-S- 4220200</td> <td style="text-align: center;">A2</td> <td style="text-align: center;">NTS</td> <td style="text-align: center;">01</td> <td style="text-align: center;">01of01</td> <td style="text-align: center;">00</td> </tr> </table>													00	FIRST SUBMISSION	24.05.2023	K.B	K.A	K.A	K.A	REV.No.	DESCRIPTION	DATE	DRAWN	ELE. CHECKED	CIVIL CHECKED	APPD. STATUS	OWNER:		 TRANSMISSION CORPORATION OF ANDHRA PRADESH LIMITED					CONTRACTOR:		AS APPLICABLE					PROJECT:		AS APPLICABLE					L.O.I No.:		AS APPLICABLE					TITLE:		SECTIONAL VIEW OF MORESTER					DRAWING No.		SIZE	SCALE	TOTAL SHEETS	SH.No.	REV.	MEIL-APT-1239-GDV-S- 4220200		A2	NTS	01	01of01	00	D
00	FIRST SUBMISSION	24.05.2023	K.B	K.A	K.A	K.A																																																																							
REV.No.	DESCRIPTION	DATE	DRAWN	ELE. CHECKED	CIVIL CHECKED	APPD. STATUS																																																																							
OWNER:		 TRANSMISSION CORPORATION OF ANDHRA PRADESH LIMITED																																																																											
CONTRACTOR:		AS APPLICABLE																																																																											
PROJECT:		AS APPLICABLE																																																																											
L.O.I No.:		AS APPLICABLE																																																																											
TITLE:		SECTIONAL VIEW OF MORESTER																																																																											
DRAWING No.		SIZE	SCALE	TOTAL SHEETS	SH.No.	REV.																																																																							
MEIL-APT-1239-GDV-S- 4220200		A2	NTS	01	01of01	00																																																																							
E	<table border="1" style="width: 100%; border-collapse: collapse;"> <tr> <td colspan="2">OWNER:</td> <td colspan="5">  TRANSMISSION CORPORATION OF ANDHRA PRADESH LIMITED </td> </tr> <tr> <td colspan="2">CONTRACTOR:</td> <td colspan="5">AS APPLICABLE</td> </tr> <tr> <td colspan="2">PROJECT:</td> <td colspan="5">AS APPLICABLE</td> </tr> <tr> <td colspan="2">L.O.I No.:</td> <td colspan="5">AS APPLICABLE</td> </tr> <tr> <td colspan="2">TITLE:</td> <td colspan="5" style="text-align: center;">SECTIONAL VIEW OF MORESTER</td> </tr> <tr> <td colspan="2">DRAWING No.</td> <td style="text-align: center;">SIZE</td> <td style="text-align: center;">SCALE</td> <td style="text-align: center;">TOTAL SHEETS</td> <td style="text-align: center;">SH.No.</td> <td style="text-align: center;">REV.</td> </tr> <tr> <td colspan="2">MEIL-APT-1239-GDV-S- 4220200</td> <td style="text-align: center;">A2</td> <td style="text-align: center;">NTS</td> <td style="text-align: center;">01</td> <td style="text-align: center;">01of01</td> <td style="text-align: center;">00</td> </tr> </table>						OWNER:		 TRANSMISSION CORPORATION OF ANDHRA PRADESH LIMITED					CONTRACTOR:		AS APPLICABLE					PROJECT:		AS APPLICABLE					L.O.I No.:		AS APPLICABLE					TITLE:		SECTIONAL VIEW OF MORESTER					DRAWING No.		SIZE	SCALE	TOTAL SHEETS	SH.No.	REV.	MEIL-APT-1239-GDV-S- 4220200		A2	NTS	01	01of01	00	E																					
OWNER:		 TRANSMISSION CORPORATION OF ANDHRA PRADESH LIMITED																																																																											
CONTRACTOR:		AS APPLICABLE																																																																											
PROJECT:		AS APPLICABLE																																																																											
L.O.I No.:		AS APPLICABLE																																																																											
TITLE:		SECTIONAL VIEW OF MORESTER																																																																											
DRAWING No.		SIZE	SCALE	TOTAL SHEETS	SH.No.	REV.																																																																							
MEIL-APT-1239-GDV-S- 4220200		A2	NTS	01	01of01	00																																																																							
F	<table border="1" style="width: 100%; border-collapse: collapse;"> <tr> <td colspan="2">DRAWING No.</td> <td style="text-align: center;">SIZE</td> <td style="text-align: center;">SCALE</td> <td style="text-align: center;">TOTAL SHEETS</td> <td style="text-align: center;">SH.No.</td> <td style="text-align: center;">REV.</td> </tr> <tr> <td colspan="2">MEIL-APT-1239-GDV-S- 4220200</td> <td style="text-align: center;">A2</td> <td style="text-align: center;">NTS</td> <td style="text-align: center;">01</td> <td style="text-align: center;">01of01</td> <td style="text-align: center;">00</td> </tr> </table>						DRAWING No.		SIZE	SCALE	TOTAL SHEETS	SH.No.	REV.	MEIL-APT-1239-GDV-S- 4220200		A2	NTS	01	01of01	00	F																																																								
DRAWING No.		SIZE	SCALE	TOTAL SHEETS	SH.No.	REV.																																																																							
MEIL-APT-1239-GDV-S- 4220200		A2	NTS	01	01of01	00																																																																							
5						6	7	8																																																																					

This drawing and design is the property of MEIL and must not be copied or lent without prior permission in writing

This drawing and design is the property of MEIL and must not be copied or lent without prior permission in writing

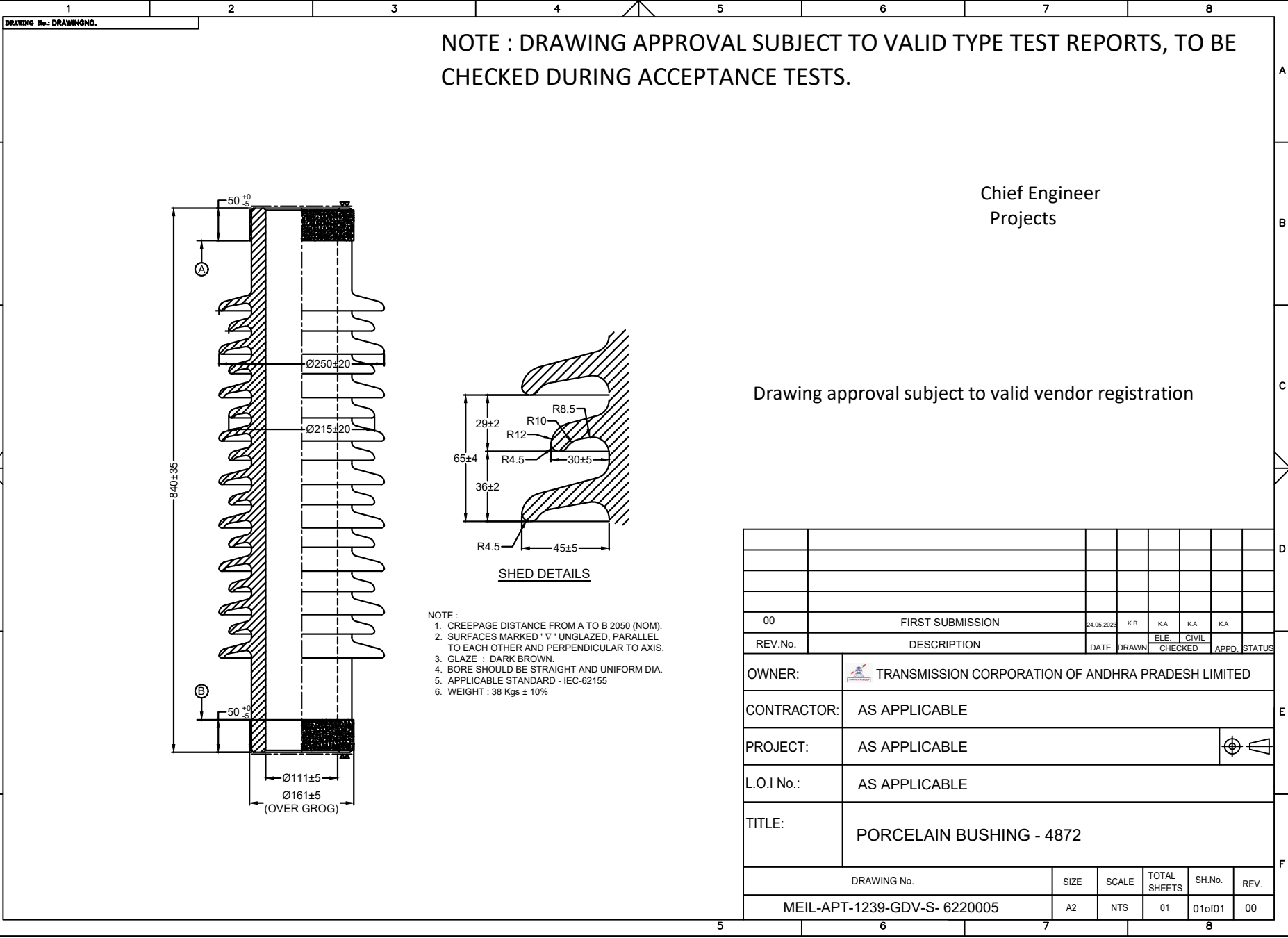

NOTE : DRAWING APPROVAL SUBJECT TO VALID TYPE TEST REPORTS, TO BE CHECKED DURING ACCEPTANCE TESTS.

Chief Engineer
Projects

Drawing approval subject to valid vendor registration

- NOTE :
1. CREEPAGE DISTANCE FROM A TO B 2050 (NOM).
 2. SURFACES MARKED ' V ' UNGLAZED, PARALLEL TO EACH OTHER AND PERPENDICULAR TO AXIS.
 3. GLAZE : DARK BROWN.
 4. BORE SHOULD BE STRAIGHT AND UNIFORM DIA.
 5. APPLICABLE STANDARD - IEC-62155
 6. WEIGHT : 38 Kgs ± 10%

00	FIRST SUBMISSION	24.05.2023	K.B	K.A	K.A	K.A
REV.No.	DESCRIPTION	DATE	DRAWN	CHECKED	APPD.	STATUS
OWNER:		TRANSMISSION CORPORATION OF ANDHRA PRADESH LIMITED				
CONTRACTOR:		AS APPLICABLE				
PROJECT:		AS APPLICABLE				
L.O.I No.:		AS APPLICABLE				
TITLE:		PORCELAIN BUSHING - 4872				
DRAWING No.		SIZE	SCALE	TOTAL SHEETS	SH.No.	REV.
MEIL-APT-1239-GDV-S- 6220005		A2	NTS	01	01of01	00

This drawing and design is the property of MEIL and must not be copied or lent without prior permission in writing

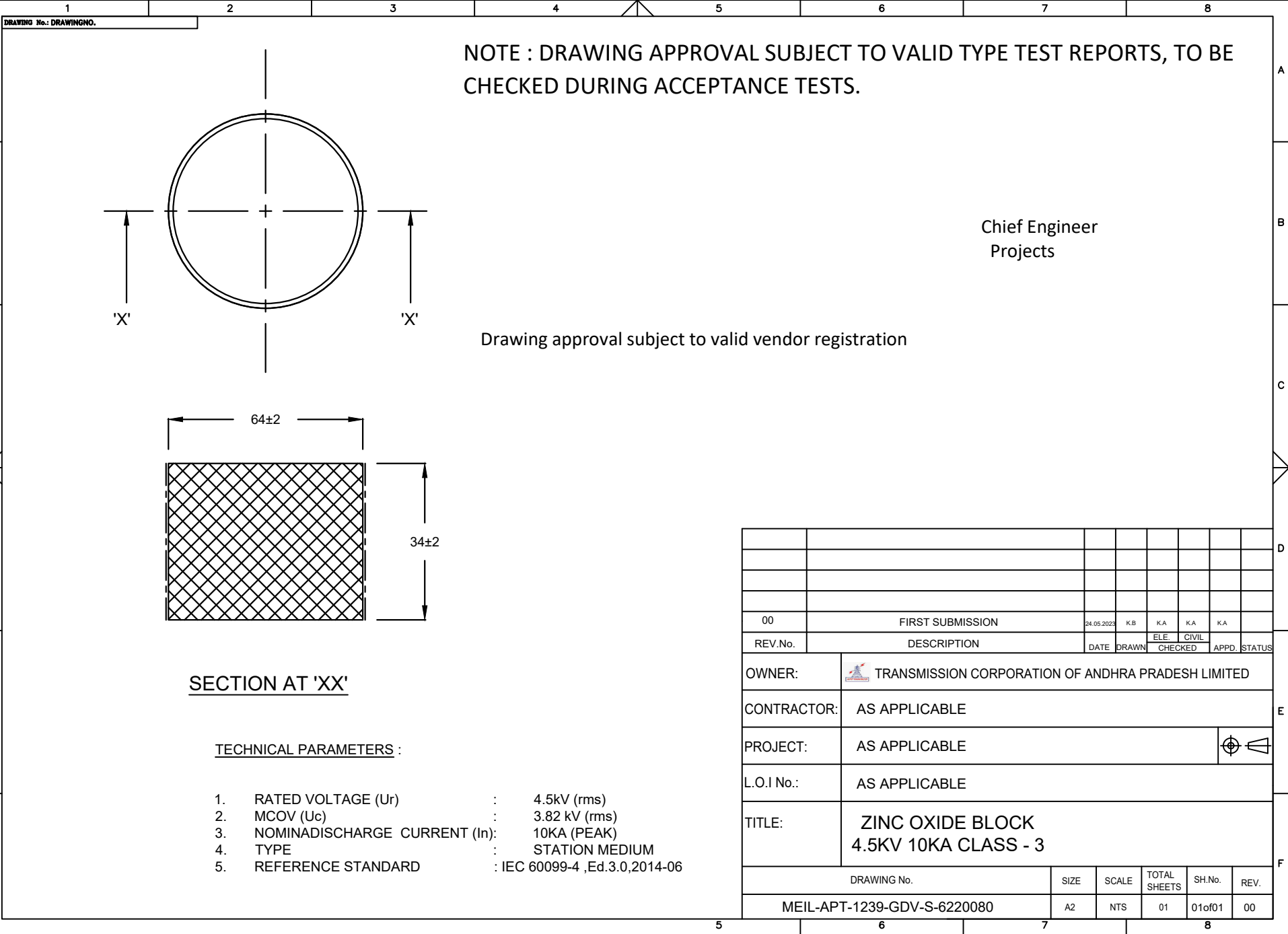

NOTE : DRAWING APPROVAL SUBJECT TO VALID TYPE TEST REPORTS, TO BE CHECKED DURING ACCEPTANCE TESTS.

Chief Engineer
Projects

Drawing approval subject to valid vendor registration

SECTION AT 'XX'

TECHNICAL PARAMETERS :

- 1. RATED VOLTAGE (Ur) : 4.5kV (rms)
- 2. MCOV (Uc) : 3.82 kV (rms)
- 3. NOMINADISCHARGE CURRENT (In): 10KA (PEAK)
- 4. TYPE : STATION MEDIUM
- 5. REFERENCE STANDARD : IEC 60099-4 ,Ed.3.0,2014-06

REV.No.	DESCRIPTION	DATE	DRAWN	CHECKED	APPD.	STATUS
00	FIRST SUBMISSION	24.05.2023	K.B	K.A	K.A	K.A
				ELE	CIVIL	

OWNER:	TRANSMISSION CORPORATION OF ANDHRA PRADESH LIMITED					
CONTRACTOR:	AS APPLICABLE					
PROJECT:	AS APPLICABLE					
L.O.I No.:	AS APPLICABLE					
TITLE:	ZINC OXIDE BLOCK 4.5KV 10KA CLASS - 3					
DRAWING No.		SIZE	SCALE	TOTAL SHEETS	SH.No.	REV.
MEIL-APT-1239-GDV-S-6220080		A2	NTS	01	01of01	00

This drawing and design is the property of MEIL and must not be copied or lent without prior permission in writing

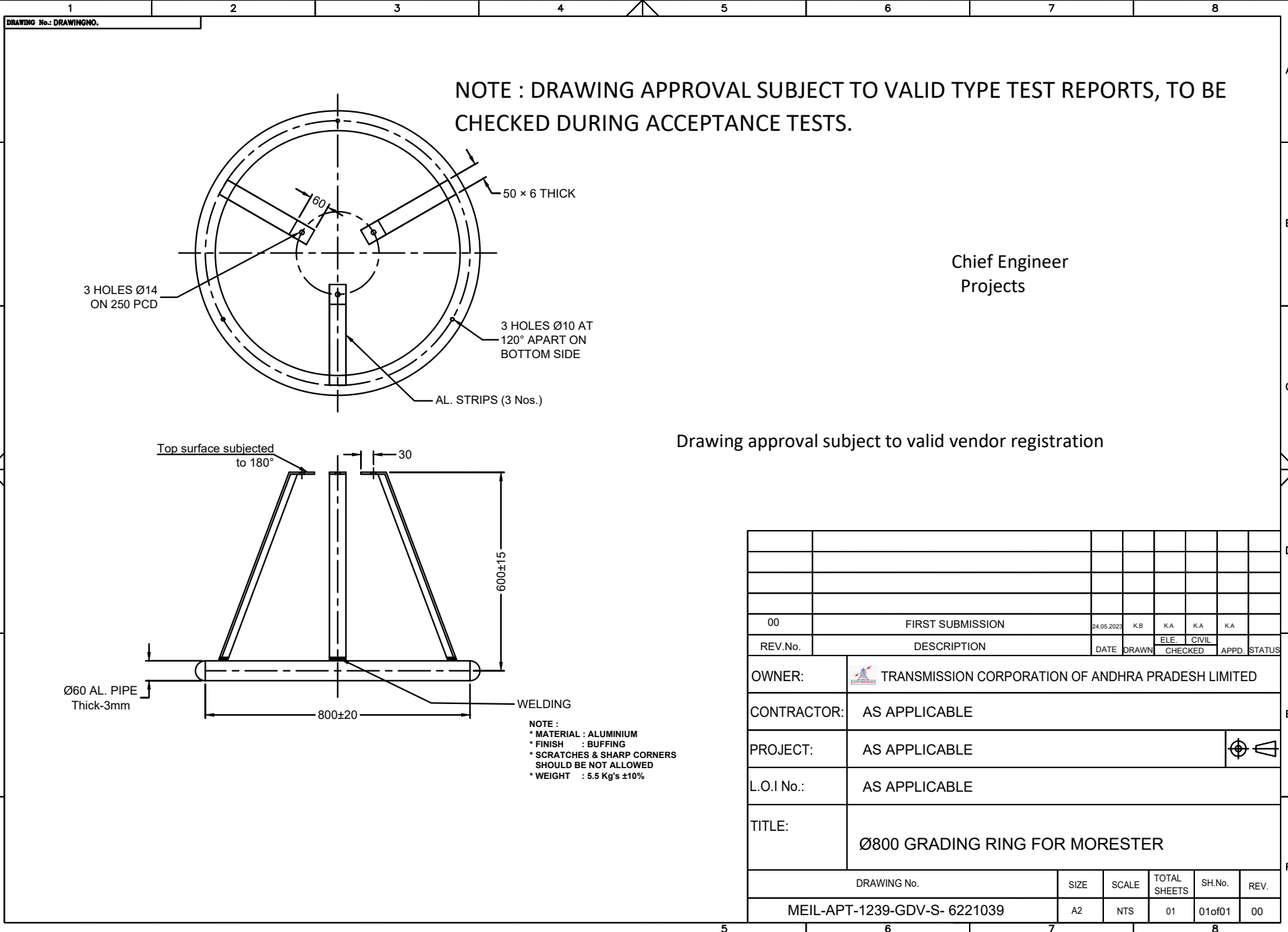

NOTE : DRAWING APPROVAL SUBJECT TO VALID TYPE TEST REPORTS, TO BE CHECKED DURING ACCEPTANCE TESTS.

Chief Engineer
Projects

Drawing approval subject to valid vendor registration

00	FIRST SUBMISSION	24.05.2024	K.B	K.A	K.A	K.A	
REV.No.	DESCRIPTION	DATE	DRAWN	CHECKED	CIVIL	APPD.	STATUS
OWNER:		TRANSMISSION CORPORATION OF ANDHRA PRADESH LIMITED					
CONTRACTOR:		AS APPLICABLE					
PROJECT:		AS APPLICABLE					
L.O.I No.:		AS APPLICABLE					
TITLE:		Ø800 GRADING RING FOR MORESTER					
DRAWING No.		SIZE	SCALE	TOTAL SHEETS	SH.No.	REV.	
MEIL-APT-1239-GDV-S- 6221039		A2	NTS	01	01of01	00	

NOTE :
 * MATERIAL : ALUMINIUM
 * FINISH : BUFFING
 * SCRATCHES & SHARP CORNERS SHOULD BE NOT ALLOWED
 * WEIGHT : 5.5 Kg's ±10%

This drawing and design is the property of MEIL and must not be copied or lent without prior permission in writing

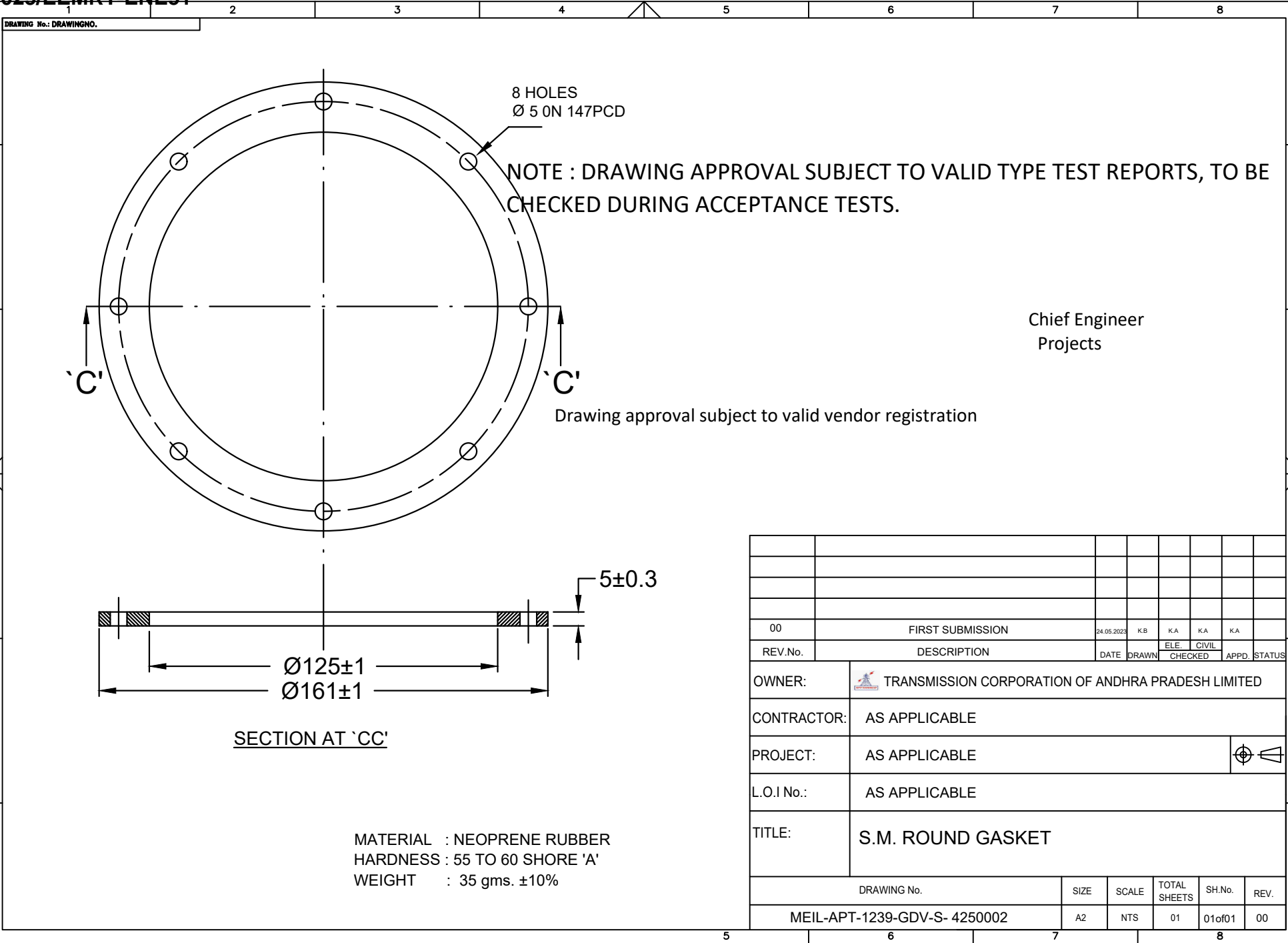

00	FIRST SUBMISSION	24.05.2023	K.B	K.A	K.A	K.A
REV.No.	DESCRIPTION	DATE	DRAWN	CHECKED	APPD.	STATUS
OWNER:		TRANSMISSION CORPORATION OF ANDHRA PRADESH LIMITED				
CONTRACTOR:		AS APPLICABLE				
PROJECT:		AS APPLICABLE				
L.O.I No.:		AS APPLICABLE				
TITLE:		S.M. ROUND GASKET				
DRAWING No.		SIZE	SCALE	TOTAL SHEETS	SH.No.	REV.
MEIL-APT-1239-GDV-S- 4250002		A2	NTS	01	01of01	00

DRAWING No.: DRAWINGNO.

NOTE : DRAWING APPROVAL SUBJECT TO VALID TYPE TEST REPORTS, TO BE CHECKED DURING ACCEPTANCE TESTS.

Chief Engineer
Projects

Drawing approval subject to valid vendor registration

This drawing and design is the property of MEIL and must not be copied or lent without prior permission in writing

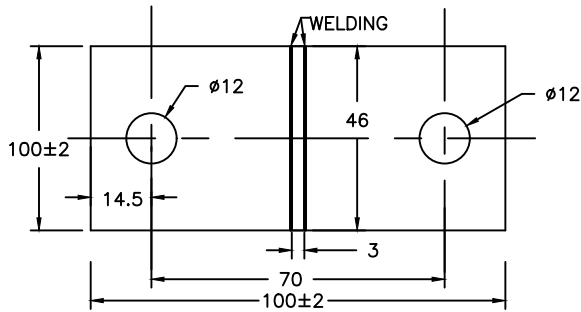
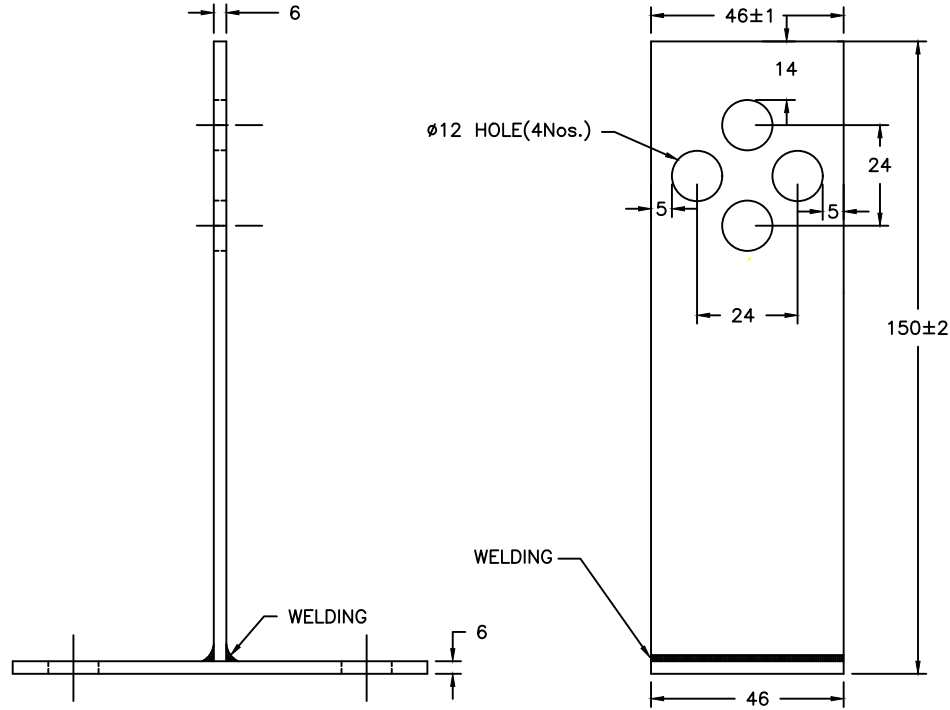

MATERIAL : HDG

00	FIRST SUBMISSION	24.05.2023	K.B	K.A	K.A	K.A
REV.No.	DESCRIPTION	DATE	DRAWN	ELE. CHECKED	CIVIL	APPD. STATUS
OWNER:		TRANSMISSION CORPORATION OF ANDHRA PRADESH LIMITED				
CONTRACTOR:		AS APPLICABLE				
PROJECT:		AS APPLICABLE				
L.O.I No.:		AS APPLICABLE				
TITLE:		S.M – MOUNTING BRACKET				
DRAWING No.		SIZE	SCALE	TOTAL SHEETS	SH.No.	REV.
MEIL-APT-1239-GDV-S-4250010		A2	NTS	01	01 of 01	00

DRAWING No.: DRAWINGNO.

Drawing approval subject to valid vendor registration

**CHIEF ENGINEER /PROJECTS
APTRANSCO/VISVIJAYAWADA**

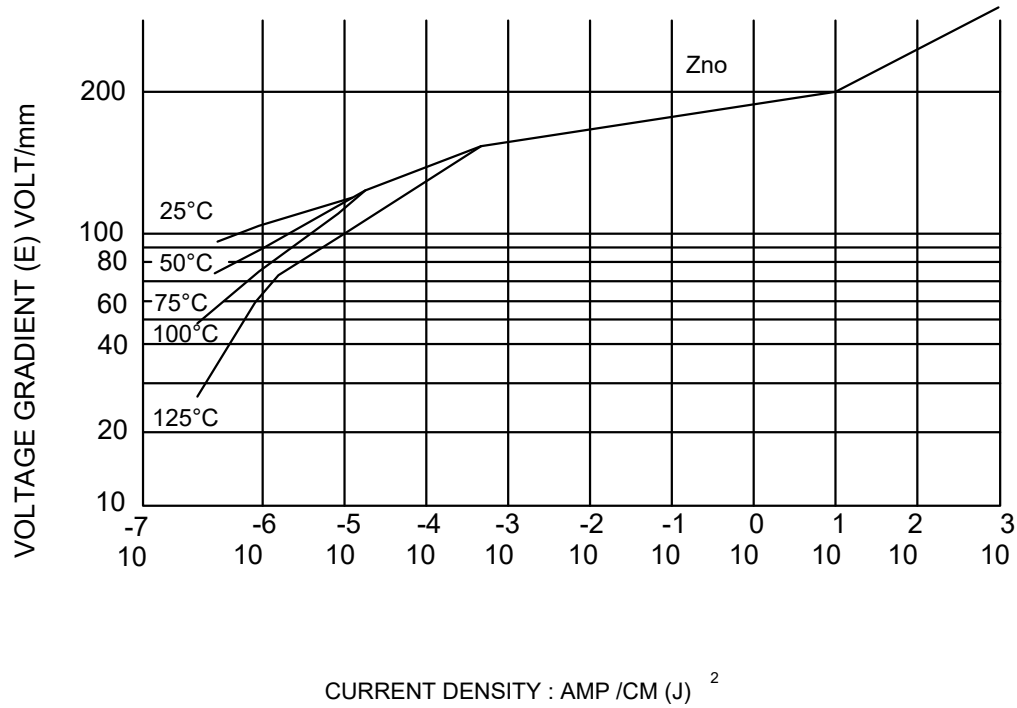

This drawing and design is the property of MEIL and must not be copied or lent without prior permission in writing

00	FIRST SUBMISSION	24.05.2023	KB	KA	KA	KA	
REV.No.	DESCRIPTION	DATE	DRAWN	CHECKED	APPD.	STATUS	
OWNER:		TRANSMISSION CORPORATION OF ANDHRA PRADESH LIMITED					
CONTRACTOR:		AS APPLICABLE					
PROJECT:		AS APPLICABLE					
L.O.I No.:		AS APPLICABLE					
TITLE:		CHARACTERISTIC CURVES OF ZnO ELEMENTS					
DRAWING No.			SIZE	SCALE	TOTAL SHEETS	SH.No.	REV.
MEIL-APT-1239-GDV-S- 8221010			A2	NTS	01	01of01	00

DRAWING No.: DRAWINGNO.

Drawing approval subject to valid vendor registration

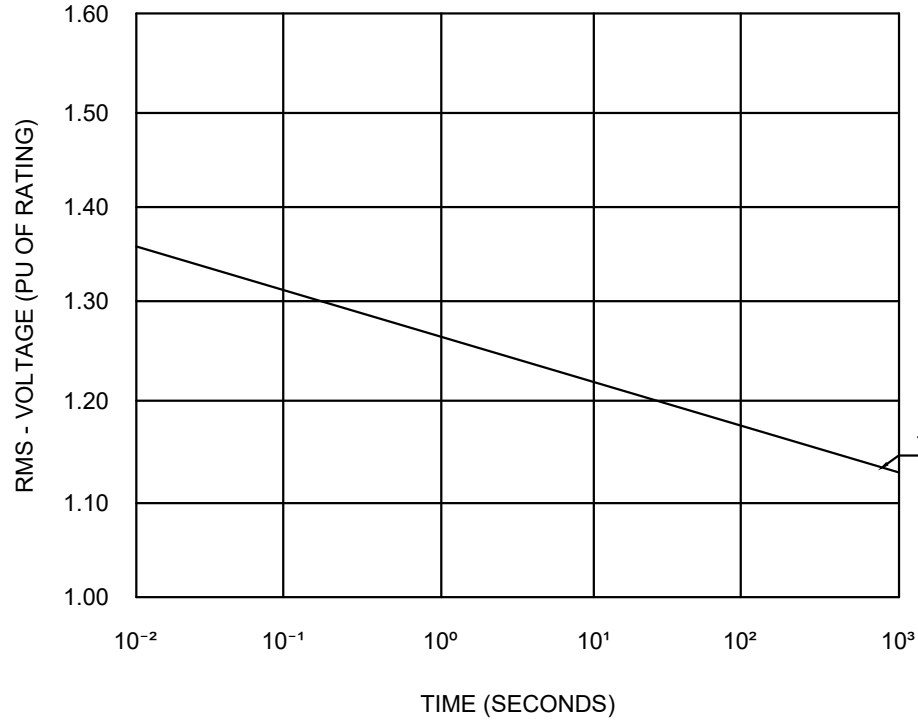

1) TOV CAPABILITY WITHOUT ENERGY ABSORPTION

**CHIEF ENGINEER /PROJECTS
APTRANSCO/Vs/VIJAYAWADA**

00	FIRST SUBMISSION	24.05.2023	K.B	K.A	K.A	K.A
REV.No.	DESCRIPTION	DATE	DRAWN	CHECKED	APPD.	STATUS
OWNER:	TRANSMISSION CORPORATION OF ANDHRA PRADESH LIMITED					
CONTRACTOR:	AS APPLICABLE					
PROJECT:	AS APPLICABLE					
L.O.I No.:	AS APPLICABLE					
TITLE:	POWER FREQUENCY VOLTAGE Vs TIME CHARACTERISTICS (10 KA)					
DRAWING No.		SIZE	SCALE	TOTAL SHEETS	SH.No.	REV.
MEIL-APT-1239-GDV-S- 8221019		A2	NTS	01	01of01	00

This drawing and design is the property of MEIL and must not be copied or lent without prior permission in writing

1) Minimum 300mm plinth shall be maintained for CT/PT/CVT/Isolators in the substation during foundation works to ensure safe live to ground clearances as per IE rules.

2) Since the supply of terminal connectors is not in the scope of manufacturer as mentioned in the drawings, the EPC contractors shall be instructed to supply the same in line with CT/PT/CVT/Isolators requirement and compatibility.

This drawing and design is the property of MEIL and must not be copied or lent without prior permission in writing

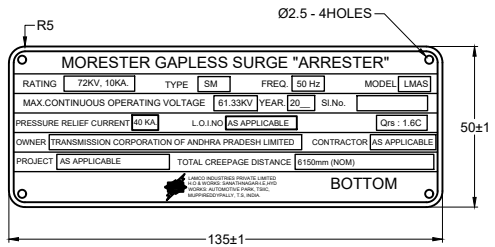
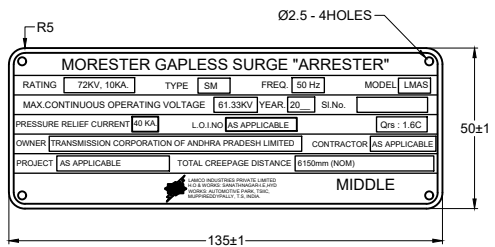
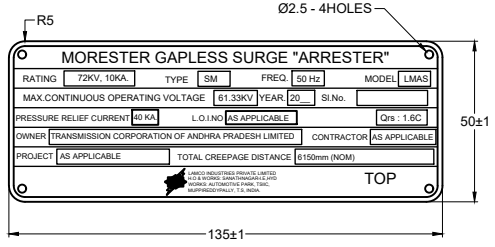

NOTE: ± 0.05
 1. MATERIAL : THICKNESS 0.51mm (25SWG) ALUMINIUM SHEET.
 2. PRINTING :
 a. BORDER LINE AND LETTERS WITH ON BLACK BACKGROUND.
 b. LETTER 'L' IN MONOGRAM IS BLACK ON WHITE BACK GROUND.
 c. RECTANGULAR BLANKS WHITE, LETTERS BLACK.
 d. LETTERS TO BE ETCHED.

Chief Engineer
Projects

Drawing approval subject to valid vendor registration

04	FIRST SUBMISSION	12.06.2023	K.B	K.A	K.A	K.A
REV.No.	DESCRIPTION	DATE	DRAWN	CHECKED	APPD.	STATUS
	OWNER: TRANSMISSION CORPORATION OF ANDHRA PRADESH LIMITED					
	CONTRACTOR: AS APPLICABLE					
	PROJECT: AS APPLICABLE					
	L.O.I No.: AS APPLICABLE					
	TITLE: GENERAL NAME PLATE MORESTER					
	DRAWING No.	SIZE	SCALE	TOTAL SHEETS	SH.No.	REV.
	MEIL-APT-1239-GDV-S- 8004401	A2	NTS	01	01of01	04

This drawing and design is the property of MEIL and must not be copied or lent without prior permission in writing

NOTE : DRAWING APPROVAL SUBJECT TO VALID TYPE TEST REPORTS, TO BE CHECKED DURING ACCEPTANCE TESTS.

MORESTER GAPLESS SURGE "ARRESTER"			
RATING	216KV, 10 KA	MODEL	LMAS
MAX. CONTINUOUS OPERATING VOLTAGE	184 KV rms		
TYPE	SM		
PRESSURE RELIEF CURRENT	40 KA		
FREQ	50 Hz	YEAR	20
		Sl. No.	
Qrs : 1.6C	BIL	1050 KVp	UNIT
			POSITION
OWNER	TRANSMISSION CORPORATION OF ANDHRA	72kV	A
	PRADESH LIMITED	72kV	B
CONTRACTOR	AS APPLICABLE	72kV	C
L.O.I.NO	AS APPLICABLE		
PROJECT	AS APPLICABLE		
TOTAL CREEPAGE DISTANCE	6150 mm (NOM)		
 LAMCO INDUSTRIES PRIVATE LIMITED H.O & WORKS: SANATHNAGAR-I.E.HYD WORKS: AUTOMOTIVE PARK, TSIIC, MUPPIREDDYPALLY, T.S, INDIA.			

85±1.0



95±1.0

Ø2.5 HOLES (4Nos)

Chief Engineer
Projects

Drawing approval subject to valid vendor registration

- NOTE: ±0.05
- 1) MATERIAL: THICKNESS 0.51mm (25 SWG) ALUMINIUM SHEET.
 - 2) PRINTING:-
 - a) BORDER LINE AND LETTERS WHITE ON BLACK BACKGROUND.
 - b) LETTER 'L' IN MONOGRAM IS BLACK ON WHITE BACKGROUND.
 - c) RECTANGULAR BLANKS WHITE, LETTERS BLACK.
 - d) LETTERS TO BE ETCHED.

03	FIRST SUBMISSION	12.06.2023	KB	KA	KA	KA	
REV.No.	DESCRIPTION	DATE	DRAWN	CHECKED	APPD.	STATUS	
OWNER:	 TRANSMISSION CORPORATION OF ANDHRA PRADESH LIMITED						
CONTRACTOR:	AS APPLICABLE						
PROJECT:	AS APPLICABLE						
L.O.I No.:	AS APPLICABLE						
TITLE:	MASTER NAME PLATE						
DRAWING No.		SIZE	SCALE	TOTAL SHEETS	SH.No.	REV.	
MEIL-APT-1239-GDV-S- 8004410		A2	NTS	01	01of01	03	