

NOTE:-1.Drawings approval subject to valid type test reports,
to be checked during acceptance tests.

7215530/2023/EEMRT-ENE51





GR POWER SWITCHGEAR LIMITED

PLOT NO:27/B IDA JEEDIMETLA
HYDERABAD

2.For EPC contractors only.

LIST OF 220 KV STD ISOLATOR DRAWINGS/DOCUMENTS

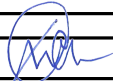
CUSTOMER :	SLNO.	DRG.NO.	REV	DESCRIPTION OF DRAWINGS/DOCUMENTS
M/s TRANSMISSION CORPORATION OF ANDHRA PRADESH LIMITED	1	3. GR APT 01	0	220 KV , 1200 AMPS,TP,DB,RT,ISOLATOR WITH OUT E. S
	2	4. GRM APT 02	0	MAIN SWITCH CONTACT ASSEMBLY (1200 A)
	3	4. GM APT 03	0	MOTOR OPERATING MECHANISM FOR 220 KV ISOLATOR
	4	4. GM APT 04	0	SECHMATIC DIAGRAM DETAILS FOR 220 KV M/S.
	5	4. GZ APT 05	0	NAME PLATE DETAILS FOR 220 KV
Drawing approval subject to valid vendor registration				
CHIEF ENGINEER/PROJECTS APTRANSCO/VIS/Vijayawada				

		
PREPARED BY	CHECKED BY	APPROVED BY

NOTE:-1. Drawings approval subject to valid type test reports, to be checked during acceptance tests.

2. For EPC contractors only.

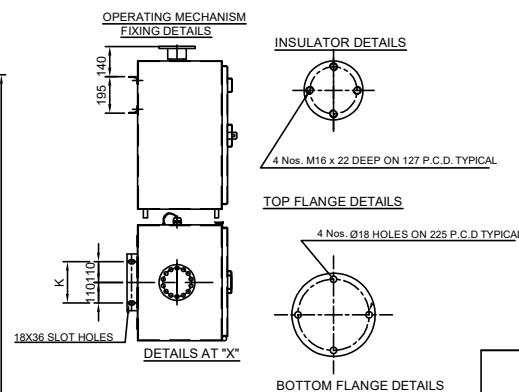
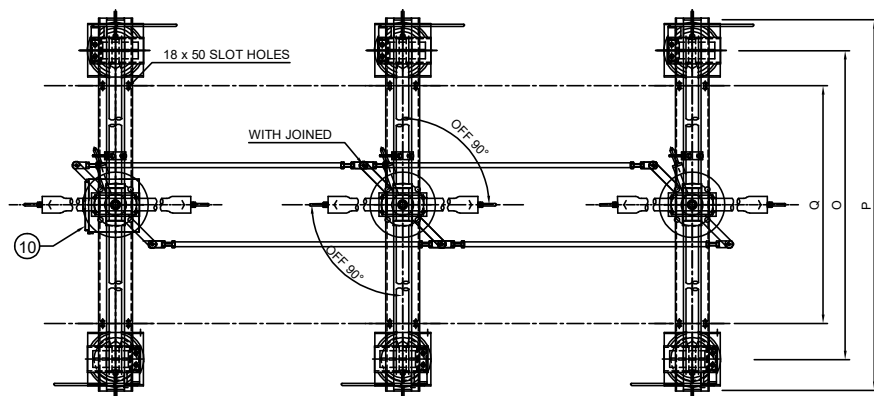
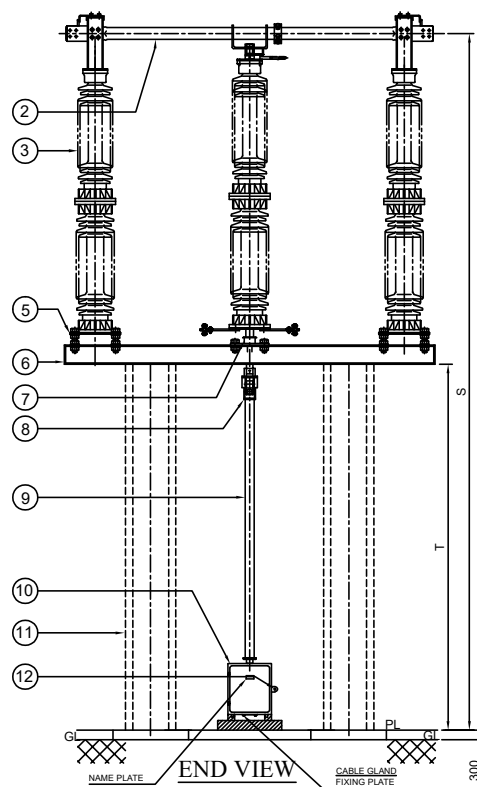
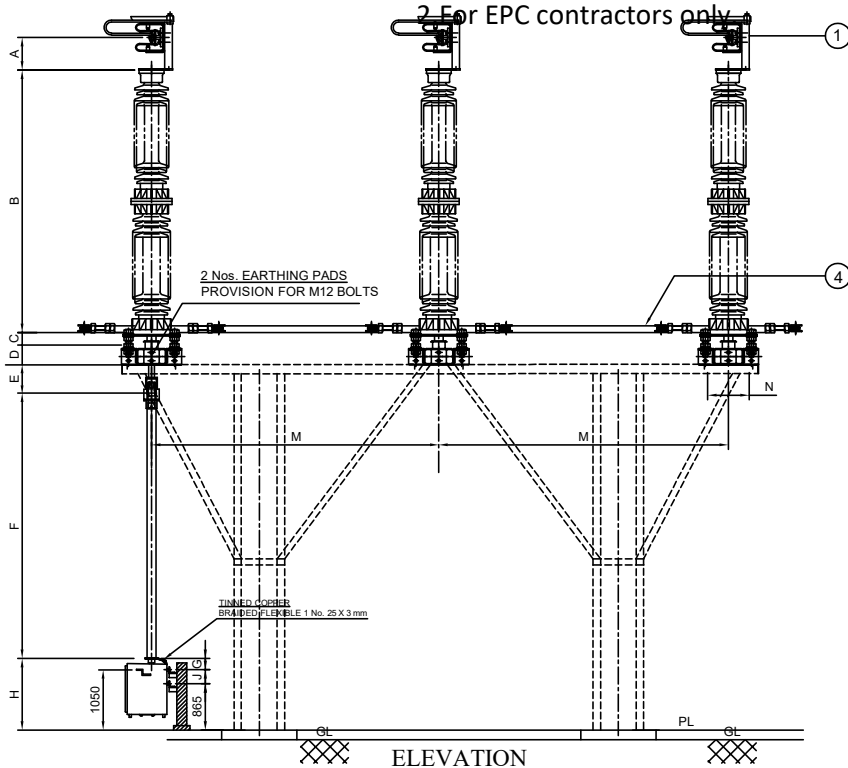

PART LIST:

1. FIXED CONTACT ASSEMBLY
2. MOVING CONTACT ASSEMBLY
3. INSULATOR STACK (NOT IN OUR SCOPE OF SUPPLY)
4. TANDEM PIPE (32 NB, G.I. PIPE)
5. ELEVATOR PLATE (12 mm THICK)
6. BASE CHANNEL (150 x 75 x 5 mm THICK MS CHANNEL)
7. ROTATING SHAFT WITH LEVER ARM & CLAMP (M.S. HOT DIP GALVANIZED)
8. UNIVERSAL JOINT ARRANGEMENT
9. DOWN OPERATING PIPE (50 NB, G.I. PIPE)
10. OPERATING MECHANISM FOR M.S. (MOTOR)
11. SUPPORTING STRUCTURE (NOT IN OUR SCOPE OF SUPPLY)
12. PROVISION FOR PADLOCK

6 Nos.	244Q
3 Nos.	721
9 Nos.	
2 Nos.	
6 Nos.	
3 Nos.	
3 Nos.	
1 No.	
1 No.	
1 No.	
1 Set.	
1 No.	

REFERENCE DRAWINGS:

- FOR ISOLATOR CONTACT DETAILS (1200A) ----- 4. GRM APT 02
- FOR OPERATING MECHANISM DETAILS (M.S.) ----- 4. GM APT 03
- FOR SCHEMATIC DIAGRAM DETAILS (M.S.) ----- 4. GM APT 04
- FOR NAME PLATED DETAILS ----- 4. GZ APT 05

Thickness of Silver plating : 15 Microns Minimum

NOTES:

1. ALL DIMENSIONS ARE IN MILLIMETERS
2. ALL FERROUS PARTS ARE HOT DIP GALVANIZED (87 MICRONS)
3. ALL NON-FERROUS CONTACT POINTS ARE SILVER PLATED (15 MICRONS)
4. THE INDICATED DIMENSIONS ARE SUBJECTED TO THE MANUFACTURING TOLERANCE:
 UP TO 50 mm ---±3%; 51 TO 100 mm ---±2%;
 101 TO 300 mm ---±1%; ABOVE 300 mm ---±0.5%;
5. SHORT TIME CURRENT RATING 40 KA rms. FOR 3 Sec.
6. APPLICABLE STANDARD : IS:9921 PART I TO V ; IEC : 62271 - 102
7. ROTATING STOOL BASE HAVING 2 Nos. SEALED BALL BEARINGS OF ADEQUATE SIZE
8. SUPPORT STRUCTURE & INSULATORS INCLUDING FIXING HARDWARE NOT IN OUR SCOPE OF SUPPLY

ELECTRICAL PARAMETERS

- 1. NOMINAL SYSTEM VOLTAGE : 220 kV
- 2. HIGHEST SYSTEM VOLTAGE : 245 kV
- 3. P.F. WITHSTAND VOLTAGE : 460 kV rms
- 4. IMPULSE WITHSTAND VOLTAGE : 1050 kV PEAK

BASE FIXING DETAILS 18 x 50 SLOT HOLES

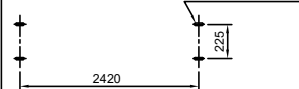

WEIGHT:

NET WEIGHT OF THE ISOLATOR METALLICS EXCLUDING INSULATOR : 800 Kg. (Approx.)

CHIEF ENGINEER/PROJECTS
APTRANSCO/VIS/Vijayawada

REVISIONS			
D	C	B	A

TITLE:
G.A. OF 220 kV, 1200 AMPS,
TP, HDB, RT, ISOLATOR WITH OUT E.S.

SCALE: N.T.S	
DATE	21/03-2023
DRAWN	
CHECKED	
APPROVED	
DRG.NO:	3. GR APT 01
REV	

DIMENSIOSNS																							
A	B	C	D	E	F	G	H	I	J	K	L	M	N	O	P	Q	R	S	T	U	V	W	X
175	2300	75	150	205	1395	140	1200	NA	195	220	NA	4500	225	3200	3600	2420	NA	5500	2800	NA	NA	NA	NA

GR POWER SWITCHGEAR LTD.,
JEEDIMETLA HYDERABAD-500 055 INDIA

FIXED CONTACT ASSEMBLY:

NOTE:-1. Drawings approval subject to valid type test reports, to be checked during acceptance tests.
2. For EPC contractors only.

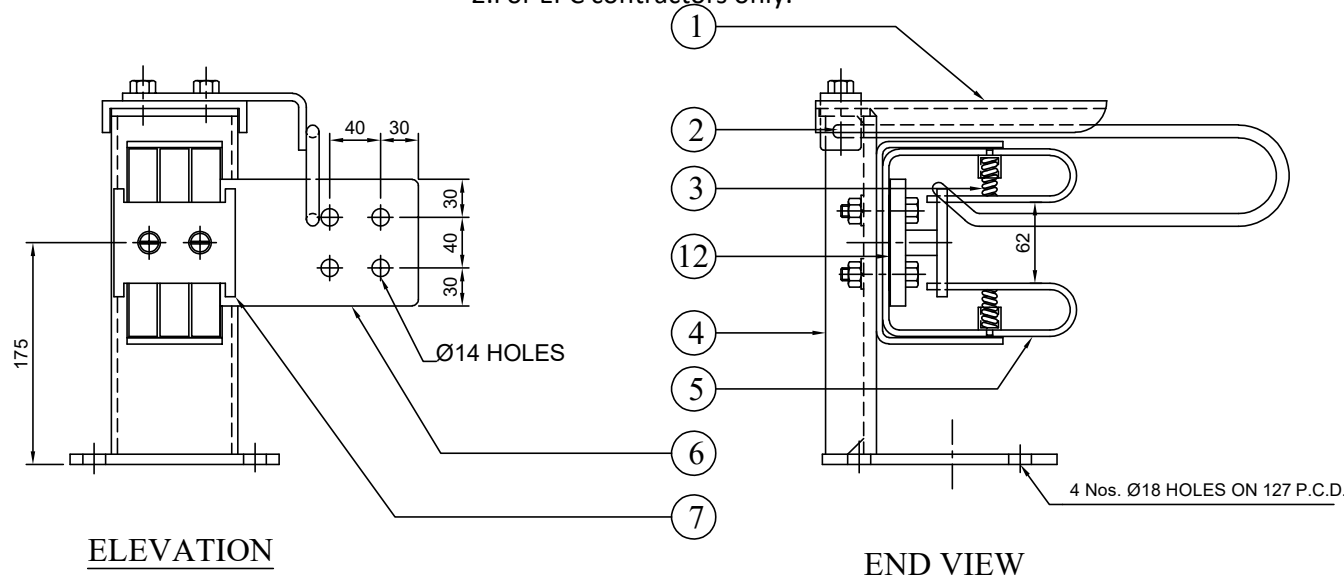

ELEVATION

END VIEW

MOVING CONTACT ASSEMBLY

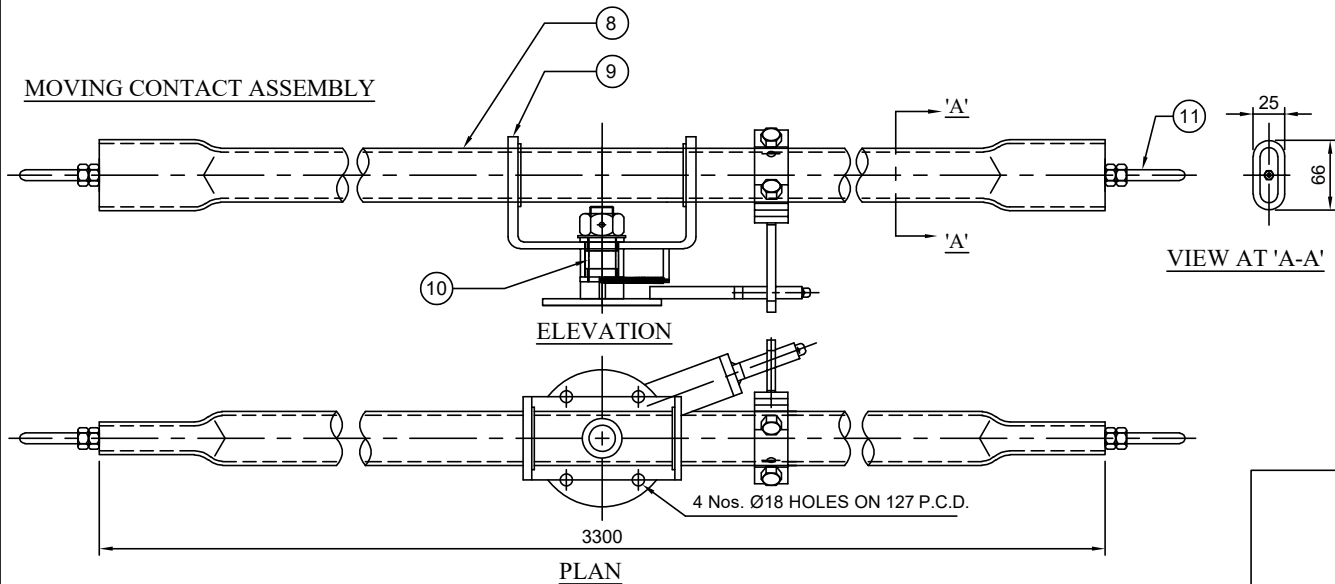

ELEVATION

VIEW AT 'A-A'

PLAN

PART LIST:

- | | |
|---|--------|
| 1. HOOD (18 SWG M.S. HDG) | 06 Nos |
| 2. ARCING HORNS (Ø10 ROD M.S. HDG) | 06 Nos |
| 3. SPRINGS (Ø2 mm STAINLESS STEEL.) | 36 Nos |
| 4. SUPPORTING CHANNEL (115 x 40 mm M.S. HDG) | 06 Nos |
| 5. JAWS (32 x 4 HDEC STRIP 3 Nos. SILVER PLATED) | 18 Nos |
| 6. JUMPER PLATE (100 x 12 ALU. FLAT) | 06 Nos |
| 7. SPACER (ALUMINUM) | 06 Nos |
| 8. MOVING CONTACT ARM (50 OD x 41 ID CU. TUBE) | 03 Nos |
| 9. MC SUPPORT WITH NYLON BUSH | 06 Nos |
| 10. CENTER MECHANISM (M.S. HDG, TURN & TWIST MECHANISM) | 03 Nos |
| 11. ARCING HORN FOR MOVING CONTACT (Ø10 ROD M.S. HDG) | 06 Nos |
| 12. BI-METALLIC SHEET (2 mm THICK Alu. + Cu.) | 06 Nos |

NOTE:

- ALL DIMENSIONS ARE IN MILLIMETER
- ALL FERROUS PARTS ARE HOT DIP GALVANIZED
- ALL NON-FERROUS CONTACT POINTS ARE SILVER PLATED 15 MICRONS REMAINING CONTACT AREA TIN PLATED.
- THE MOVING CONTACT ASSEMBLY SHOWN FOR TURN & TWIST ASSEMBLY

Drawing approval subject to valid vendor registration

CHIEF ENGINEER/PROJECTS
APTRANSCO/VS/Vijayawada

245
BOQ
721

- Minimum 300mm plinth shall be maintained for CT/PT/CVT/ Isolators/IVT in the substation during foundation works to ensure safe live to ground clearance as per IE rules.
- Since the supply of terminal connectors is not in the scope of manufacturers as mentioned in the drawings. The EPC contractors shall be instructed to supply the same in line with CT/PT/CVT/Isolator /IVTs requirement and capability.

REVISIONS			
D	C	B	A

TITLE:
MAIN SWITCH CONTACT ASSEMBLY
(FOR 220 kV 1200 Amps)



GR POWER SWITCHGEAR LTD.,
JEEDIMETLA HYDERABAD-500 055 INDIA

SCALE:N.T.S	
DATE	21-03-2023
DRAWN	
CHECKED	
APPROVED	
DRG.NO:	REV
4. GRM APT 02	

to be checked during acceptance tests.
2. For EPC contractors only.

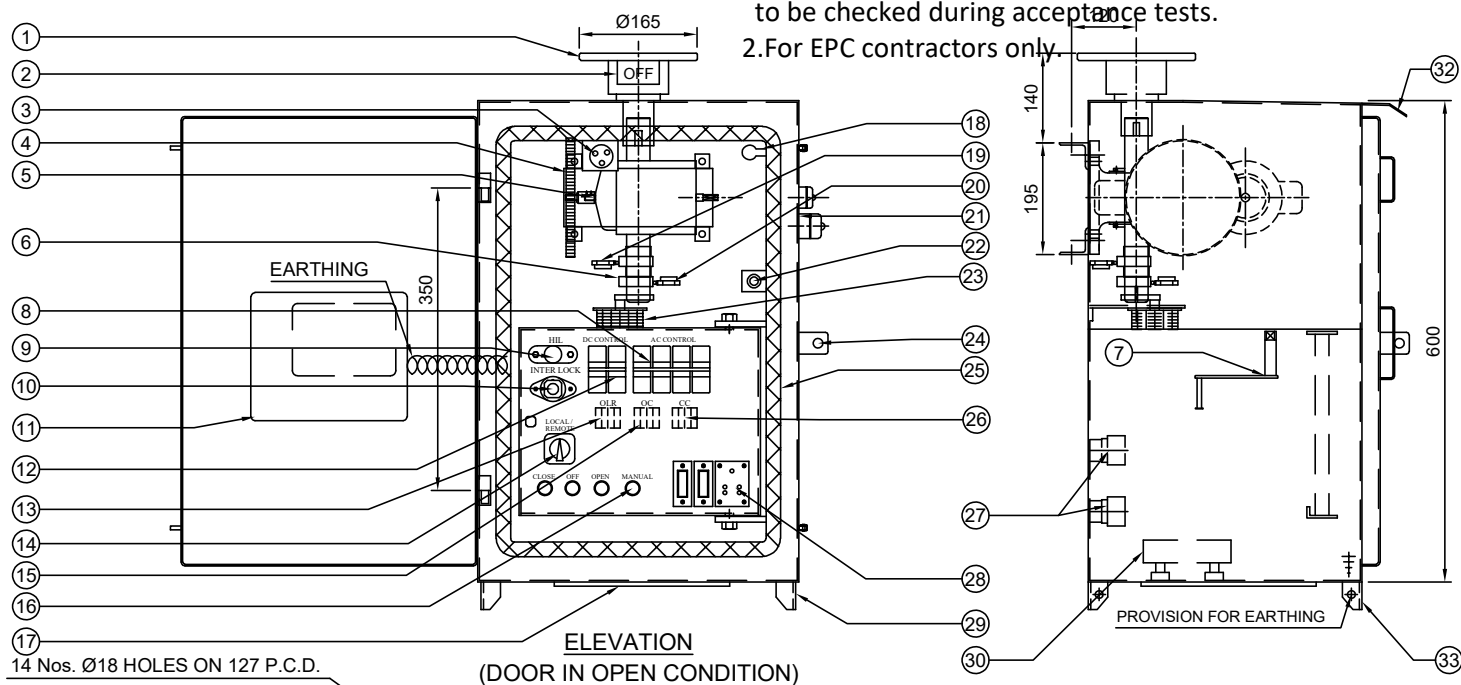

- PART LIST:**
- OUTPUT FLANGE (8 mm THICK, 14 HOLES)
 - ON/OFF INDICATOR
 - THERMOSTAT (30 TO 85°C RECOMMENDED SETTING 40°)
 - GEAR BOX (SPUR / WORM & WORM SHAFT, RATIO 1 : 630)
(MATERIAL : EN8 / FORGED STEEL)
 - MOTOR (Ø3, 415 Volts, 0.5 HP MOTOR)
 - LIMIT SWITCH OPERATING CAM
 - OPERATING HANDLE FIXED TO DOOR
 - AC CONTROL SWITCH (4 POLE MCB) S1
 - PUSH CAP (FOR HIL)
 - HANDLE INTERLOCK (HIL)
 - SCHEMATIC DIAGRAM PLATE
 - DC CONTROL SWITCH (2 POLE MCB) S2
 - OVER LOAD RELAY CUM SINGLE PHASE PREVENTOR (OLR)
 - LOCAL/REMOTE SWITCH (S3)
 - OPENING CONTACTOR (OC)
 - OPEN / CLOSE / MANUAL / OFF PUSH BUTTON (PBO / PBC / PBH / EPB)
 - DETACHABLE CABLE GLANDS FIXING PLATE (WITH OUT GLANDS)
 - CUBICLE LAMP HOLDER
 - LIMIT SWITCH (LSO)
 - LIMIT SWITCH (LSC)
 - CUBICLE WITH DOOR (3 mm THICK ALU SHEET)
 - DOOR OPERATED LIGHT SWITCH (LS)
 - AUX. SWITCH (12 NO + 12 NC)
 - PROVISION FOR PAD LOCK
 - RUBBER GASKET (EPDM)
 - CLOSING CONTACTOR (CC)
 - TERMINAL BLOCK (UBT - 4 TYPE OF ELMEX OR ITS EQUIVALENT)
 - HEATER / POWER SOCKET SWITCHES (HS,PSS)
 - BOX SUPPORT
 - HEATER, 80 WATTS, 240 V
 - MANUAL OPERATING CAP / COVER
 - RAIN SHADE
 - PROVISION FOR EARTHING TERMINALS

14 Nos. Ø18 HOLES ON 127 P.C.D.

ELEVATION
(DOOR IN OPEN CONDITION)

LEFT SIDE VIEW
(DOOR IN CLOSE CONDITION)

FIXING DETAILS FOR SUPPORTING STRUCTURE

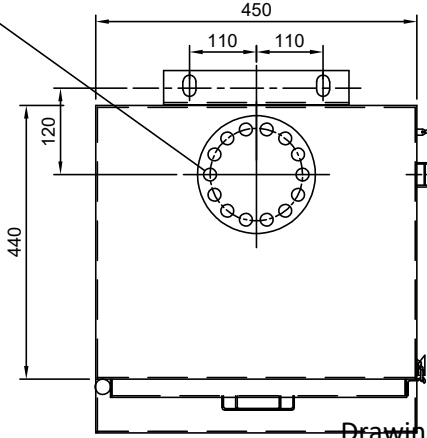
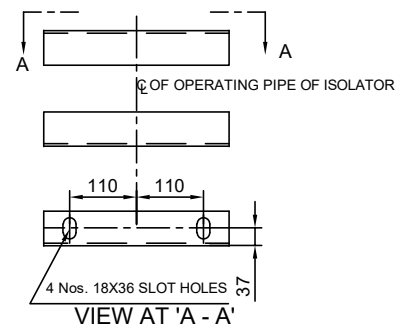

PLAN

GASKET DETAILS

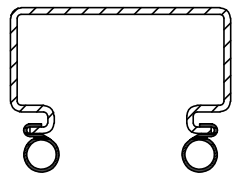

Drawing approval subject to valid vendor registration

NOTE :

- ALL DIMENSIONS ARE IN MILLIMETERS
- CUBICLE WILL BE NATURAL ALUMINIUM FINISH FOR INSIDE AND OUTSIDE.
- DEGREE OF PROTECTION IP:55 AS PER IS/IEC 60529
- 20% SPARE TERMINALS WILL BE PROVIDED
- WIRING WILL BE DONE WITH 1100 V. GRADE
 - FOR POWER CIRCUIT (AC SUPPLY) : 2.5 Sq.MM Cu. STRANDED
 - FOR AUXILIARY CIRCUIT (DC SUPPLY) : 2.5 Sq.MM Cu. STRANDED P.V.C. INSULATED CONDUCTOR
- WEIGHT OF THE BOX : 80 Kg (Approx.)
- LUBRICATION OF GEARS : NON HARDENED GREASE FILLED GEAR BOX

AUX. SWITCH CONTACT DETAILS FOR ISOLATOR
(12 NO / 12 NC)

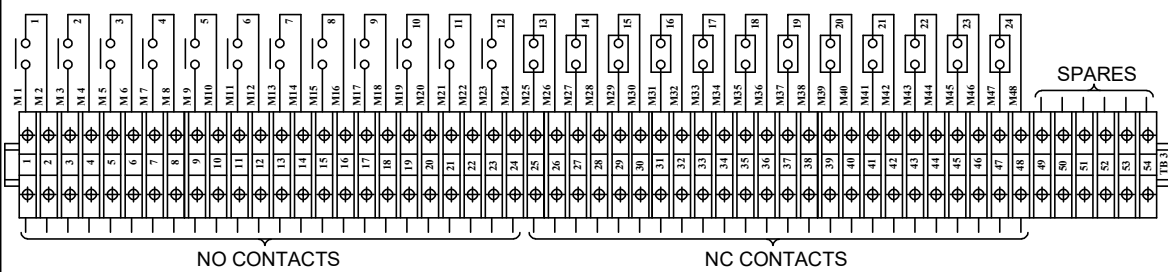

CHIEF ENGINEER/PROJECTS
APTRANSCO/VS/Vijayawada

REVISIONS				
D	C	B	A	

TITLE:
GENERAL ARRANGEMENT OF MOTOR OPERATING MECHANISM FOR 220 KV M/S.

SCALE:N.T.S	
DATE	21-03-2023
DRAWN	
CHECKED	
APPROVED	
DRG.NO:	4. GM APT 03
REV	



GR POWER SWITCHGEAR LTD.,
JEEDIMETLA HYDERABAD-500 055 INDIA

NOTE:-1. Drawings approval subject to valid type test reports,
to be checked during acceptance tests.
2. For EPC contractors only.

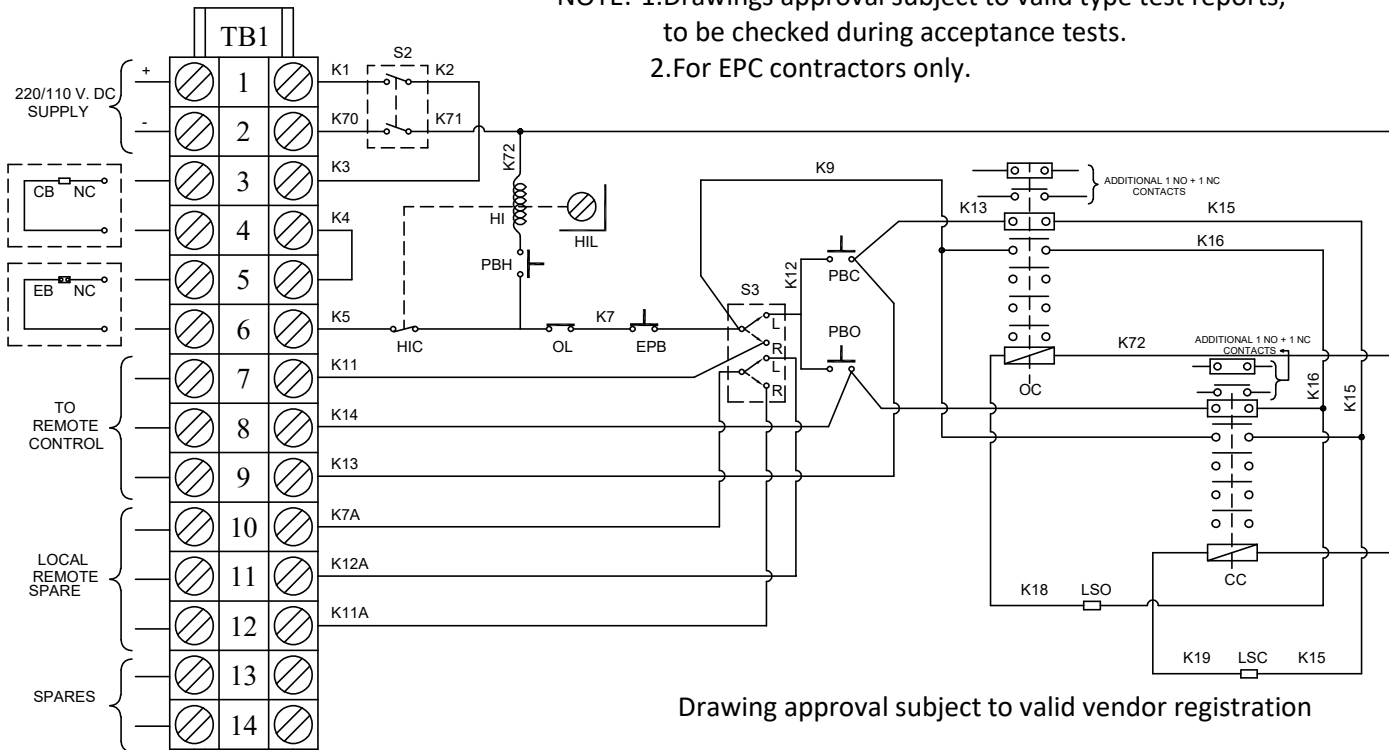

Drawing approval subject to valid vendor registration

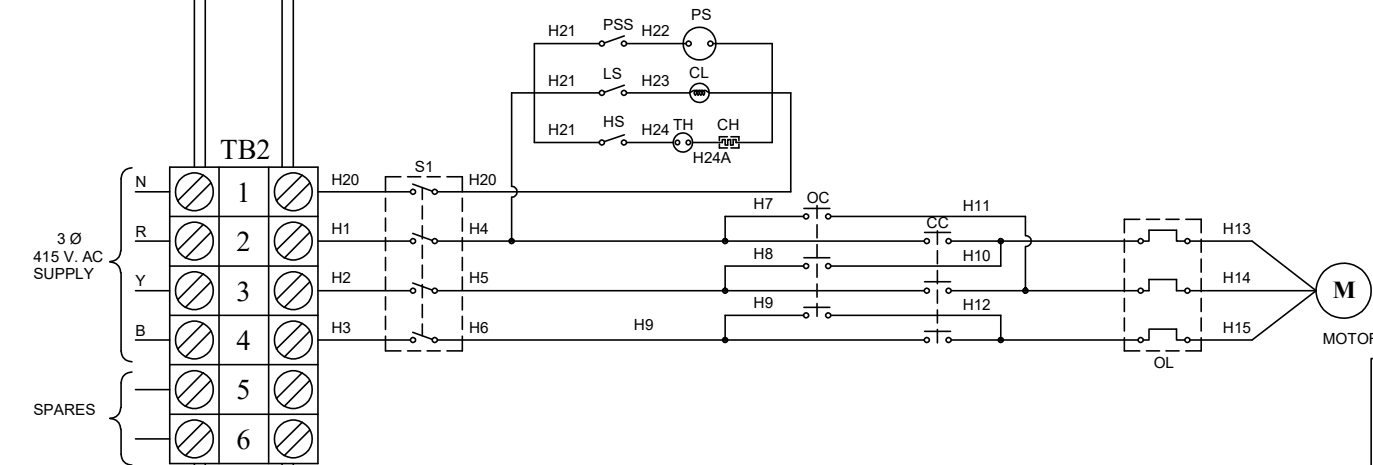

1. Minimum 300mm plinth shall be maintained for CT/PT/CVT/ Isolators/IVT in the substation during foundation works to ensure safe live to ground clearance as per IE rules.
2. Since the supply of terminal connectors is not in the scope of manufacturers as mentioned in the drawings. The EPC contractors shall be instructed to supply the same in line with CT/PT/CVT/Isolator /IVTs requirement and capability.

LEGEND	DESCRIPTION	MAKE	247
HIC	HANDLE INTERLOCK CONTACT	SWITRON/RECOM	721
M	MOTOR 3Ø 415 V. 0.5 HP	REMI/ELECEN/HEMAL/HINDUSTAN	
CH	CUBICLE HEATER 80 WATTS	KONTACT/RAMANA ELECT.	
S1	A.C. SUPPLY CONTROL SWITCH, 16 A MCB	SCHNEIDER/C&S/SIEMENS/CHINT	
S2	D.C. SUPPLY CONTROL SWITCH, 10 A MCB	SCHNEIDER/C&S/SIEMENS/CHINT	
S3	LOCAL/REMOTE SELECTOR SWITCH 16 A	SWITRON/RECOM	
OC,CC	OPEN/CLOSE CONTACTORS, 9 A	SCHNEIDER/C&S/SIEMENS/CHINT	
OL	OVER LOAD RELAY WITH SPP 1.0 TO 1.6 A	SCHNEIDER/C&S/SIEMENS/CHINT	
PBO,PBC	OPEN/CLOSE PUSH BUTTONS, 4 A	C&S/JAIBALAJI/VAISHNO/SIEMENS/TECHN	
LSO,LSC	OPEN/CLOSE LIMIT SWITCHES, 10 A	JAI BALAJI/MANI	
PBH	MANUAL HANDLE PUSH BUTTONS, 4 A	C&S/JAIBALAJI/VAISHNO/SIEMENS/TECHN	
EPB	EMERGENCY PUSH BUTTON, 4 A	C&S/JAIBALAJI/VAISHNO/SIEMENS/TECHN	
HI	HANDLE INTERLOCK COIL, 20 WATTS	SELMECH/GRPS	
HIL	MANUAL HANDLE KEY INTERLOCK	PSI/EE	
LS,PSS,HS	LIGHT, SOCKET, HEATER SWITCHES, 5A	MARU OR ITS EQUIVALENT	
CL	CUBICLE LAMP HOLDER	MARU OR ITS EQUIVALENT	
PS	POWER SOCKET, 5A	MARU OR ITS EQUIVALENT	
TB	TERMINAL BLOCKS (UBT-4)	ELMEX / CONNECTWELL / VIN MECH	
TH	THERMOSTAT	BEPL	

OPERATING INSTRUCTIONS:

1. DON'T OPERATE THE ISOLATOR WHEN THE 'CIRCUIT BREAKER' IS IN 'ON'
2. ISOLATOR OPERATION IS POSSIBLE ONLY WHEN THE INTERLOCK CONDITIONS ARE SATISFIED.
3. FOR MANUAL OPERATION FOLLOW THE FOLLOWING INSTRUCTIONS:-
 - a) BY PRESSING THE PUSH BUTTON (PBH) REMOVE THE CASTLE KEY AND KEEP THE KEY IN HANDLE LOCK AND ROTATE FOR GETTING WAY TO INSERT THE OPERATING HANDLE.
 - b) INSERT THE OPERATING HANDLE AND ROTATE IN CLOCK / ANTI CLOCK WISE DIRECTIONS FOR TO OPEN / CLOSE THE ISOLATOR.
 - c) IF MANUAL OPERATION IS NOT NEEDED RESTORE THE CASTLE KEY IN THE HANDLE INTERLOCK AND ROTATE.

CHIEF ENGINEER/PROJECTS
APTRANSCO/VS/Vijayawada

REVISIONS			
D	C	B	A

TITLE:	SCALE:N.T.S	DATE	21-08-2023
SCHEMATIC DIAGRAM FOR MOTOR CONTROL PANEL FOR 220 KV	DRAWN	CHECKED	APPROVED
GR POWER SWITCHGEAR LTD., JEEDIMETLA HYDERABAD-500 055 INDIA	DRG.NO:	4. GM APT 04	REV

NOTE:-1.Drawings approval subject to valid type test reports,
to be checked during acceptance tests.
2.For EPC contractors only.

NAME PLATE DETAILS FOR ISOLATOR

 MANUFACTURED & SUPPLIED BY GR POWER SWITCHGEAR LTD., JEEDIMETLA, HYDERABAD - 500 055	
CUSTOMER :	M/s. TRANSMISSION CORPORATION OF AP LIMITED
PROJECT :	-----
CONTRACTOR :	-----
P.O. NO :	----- Dt. : -----
TYPE :	HDB SL. NO : AS APPLICABLE YEAR OF Mfg. : 2023
RATING :	Un 220 KV ; In : 1200 A ; WEIGHT IN KG : -----
IMPLUSE(UI) :	1050 KV Peak; SWITCHING(Us): -----KV Peak;
P.F. :	.460 KV rms; STC(lth): 40 KA rms; DURATION: 3Sec;
OPERATING MECHANISM :	MOTOR, 3 Ph.,415 V, 0.5 HP
CONTROL VOLTAGE :	220/110 V DC CREEPAGE: -----

100

Control Voltage 220V DC 150

Drawing approval subject to valid vendor registration

Project, Contractor , PO, date , year of MFG shall be stamped during inspection



1. Minimum 300mm plinth shall be maintained for CT/PT/CVT/ Isolators/IVT in the substation during foundation works to ensure safe live to ground clearance as per IE rules.
2. Since the supply of terminal connectors is not in the scope of manufacturers as mentioned in the drawings. The EPC contractors shall be instructed to supply the same in line with CT/PT/CVT/Isolator /IVTs requirement and capability.

NOTES :

1. ENGRAVED LETTER SIZE : 3 mm
2. LETTER ETCHED WHITE ON BLACK BACKGROUND
3. MATERIAL : ALUMINUM
4. THICKNESS : 1 mm

CHIEF ENGINEER/PROJECTS
APTRANSCO/VS/Vijayawada

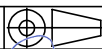
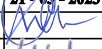
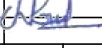
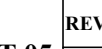
REVISIONS			
D	C	B	A

TITLE:		SCALE:N.T.S	
NAME PLATE DETAILS (FOR 220 kV ISOLATOR)		DATE	21-03-2023
		DRAWN	
		CHECKED	
		APPROVED	
 GR POWER SWITCHGEAR LTD., JEEDIMETLA HYDERABAD-500 055 INDIA		DRG.NO:	REV
		4. GZ APT 05	

SCHEDULE OF GUARANTEED TECHNICAL PARTICULARS FOR 220KV, 1200A WITHOUT EARTH SWITCH

S.No	DESCRIPTION		220 KV
1	Type/Installation	:	"DB" Double Break - OUTDOOR
2	Manufacturer's Name and country of manufacture	:	GR POWER SWITCHGEAR LTD., HYDERABAD
3	Standards according to which the isolators are manufactured.	:	IS 9921 Part I to V. & IEC 62271-102
4	Maximum design voltage at which the isolator can operate (kV).	:	245 KV
5	Frequency (Hz)	:	50 Hz
6	Rated voltage (kV)	:	220KV
7	Maximum current that can be safely interrupted by the Isolator inductive (A & % PF) Capacitive (A & % PF)	:	0.7 Amps at 0.15 p.f.
8	Continuous current rating normal (Amps) under site conditions (Amps).	:	1200 Amps
9	Rated short time current		<u>MAIN SWITCH</u>
	i) For 3 Seconds (kA rms)	:	40 KA rms
	ii) For 1 Second (kA rms)	:	Not Applicable
	iii) Rated peak short time current (KV P)	:	100 KA rms
10	Current density at the minimum cross section of		
	a) Moving blade (Amps/Sq.mm)	:	2.0 Amps/Sq.mm for HDE Cu. Tube
	b) Terminal pad	:	1.0 Amp/Sq.mm for EC grade Alu. Flat.
	c) Contacts	:	1.6 Amps/Sq.mm for HDE Cu. Flat.
11	Maximum temperature rise of current carrying parts when carrying rated current continuously (Deg.C).	:	Within the specified limits of IS/IEC 62271-102.
12	Insulation levels		
	i) Impulse withstand voltage (kV Peak) Phase to Earth Isolating Distance.	:	1050 KV Peak
	ii) Switching surge withstand voltage (kV Peak) Phase to Earth isolating distance.	:	Not applicable

S.No	DESCRIPTION		220 KV
	iii) Power Frequency withstand voltage (kV rms) Phase to Earth isolating distance.	:	460 KV rms
13	Minimum clearance in air		
	i) Between poles (mm)	:	4000 mm for a phase spacing of 4500 mm
	ii) Between live parts and earth (mm)	:	2100 mm
	iii) Between live parts when switch is open.		
	a) On the same pole (mm)	:	2800 mm
	b) Between adjacent poles (mm)	:	3000 mm
14	Rated mechanical terminal load		
	i) Load along the terminal connector side (Kg).	:	102 Kgs
	ii) Load across the terminal connector side (Kg).	:	33.7 Kgs
15	Torque required to operate the switch in Kg.m.	:	40 Kg m
16	Contact Zone		
	i) Horizontal deflection (mm)	}	Not applicable
	ii) Vertical deflection (mm)		
	iii) Total amplitude of longitudinal movement w.r.t conductor supporting fixed contact		
17	Design and construction		
	i) No. of insulators per pole	:	Three
	ii) No. of breaks per pole	:	Two
	iii) Type of closing / opening mechanism (Horizontal / vertical break straight etc.).	:	Horizontal break for Isolator
	iv. Contacts		
	a) Material and grade	:	Thickness of Silver plating : 15 Microns Minimum Hard Drawn Electrolytic Copper flat, silver plated  micron thickness.
	b) Cross-sectional area (Sq.mm)	:	768 Sq.mm for 1200A

CHIEF ENGINEER/PROJECTS
APTRANSCO/VS/Vijayawada

S.No	DESCRIPTION	220 KV	
v	Moving blades	Thickness of Silver plating : 15 Microns Minimum Hard Drawn Electrolytic Copper tube, silver plated of 0.1 micron thickness. 643 Sq.mm for 1200A 8 mm Thick MS HDG MS HDG 40 x 10 MS HDG Flat 14 swg SS wire Not encased Lessthan M8 are of stainless steel M8 and above are of MS HDG. 12 mm thick M.S. Hot dip galvanised plate MS HDG suitable for 50 ID Ball Bearing 2 Nos. below centre rotating post insulator As per GA drawings Suitable for 40 NB 6 Nos. bush bearings, brass, 16 mm ID Size. Electrical interlock between Isolator and circuit breaker. 50 mm NB Class B GI Pipe.	
	a) Material and grade		
	b) Cross-sectional area (Sq.mm)		
vi)	Contact support		
	a) Material and size of channel / block.		
vii)	Rain hood-material grade and size		
viii)	Turn and twist mechanism		
	a) Material and size of clamps		
	b) Material size of springs		
	c) Whether springs are encased		
ix)	Nuts and bolts		
	a) Size, material and grade in live parts.		
	b) Size, material and grade in other parts.		
x)	Insulator base plate material and size of plate below insulators.		
xi)	Bearings		
	a) Material and size of housing		
	b) No. of bearings, location & size		
xii)	Tandem pipe		
	a) Size, length class and No. of pipes		
	b) Size of shackle screw		
	c) No. of bearings / bush and its material and size.		
xiii)	Type of interlock		
xiv)	Down pipe size, length and class		

S.No	DESCRIPTION	220 KV
xv)	Type of universal/swivel joint	
	a) Between bearing & down pipe	: Universal joint
	b) Between down pipe and operating mechanism.	: Vernier Flange
xvi)	Operating mechanism	Motor operated mechanism for M.S
	a) Control cabinet	
	Material and thickness	: 3 mm Thick ALU Sheet
	Degree of protection	: IP : 55 as per IS 2147
	Type size and no. of cable glands.	: Compression type, 2 Nos. 19 mm. (Contractor scope of supply)
	Whether removable gland plate provided.	: Yes, removable gland plate provided.
	b) Make type, rating and Qty. of Motors	: Ø3, 415v, 0.5 HP Motor
	Auxiliary blocks	: 12 NO / 12 NC contacts for Main Switch Mani 10 A, 2 A DC breaking with 2A - 1 No.
	Terminal blocks	: UBT-4
	Insulated Wires	: 1100 V grades, 2.5 Sq.mm PVC For Auxiliary Circuit and 2.5 Sq.mm for Power circuit
	HRC Fuse	: Not Applicable, MCB's
	Space Heater	: 1 No. 230V AC. 80 Watts / Ramana Electrical
	Interlocks	: 1 Set PSI / 20 Watts magnetic - 1 No.
xvii)	Base	
	a) Size of steel sections used	: 150 X 75 mm
	b) Overall size	: 3600 x 150 x 75 mm x 5 mm
	c) Total weight	: 52 Kgs approx

for GR POWER SWITCHGEAR LTD.,



AUTHORIZED SIGNATORY

Drawing approval subject to valid vendor registration

CHIEF ENGINEER/PROJECTS
APTRANSCO/VIS/Vijayawada