

			196
			765
REV	DATE	CHANGES MADE	SIG

NOTE: 1. Drawings Approval subject to valid type test reports, to be checked during acceptance tests.
2. For EPC contractors only.



Drawing approval subject to valid vendor registration

LIST OF DRAWINGS/DOCUMENTS FOR 245KV DBR DISCONNECTOR

S NO.	TITLE	DRAWING NO.	REV	SHEET
1	GA OF 245kV 1200A 'DBR' DISCONNECTOR WITH TWO EARTH SWITCH	STD-2451016	0	1 OF 1
2	DETAILS OF MAIN CONTACT (245KV 1200A DBR DISCONNECTOR)	STD-2451017	0	1 OF 1
3	EARTH SWITCH CONTACT DETAILS (245KV DBR DISCONNECTOR)	STD-2451018	0	1 OF 1
4	GA OF MOTOR OPERATING MECHANISM FOR DISCONNECTOR	STD-2451019	0	1 OF 1
5	SCHE. DIAG OF DISCONNECTOR CONTROL PANEL AC & DC	STD-2451020	0	1 OF 2
6	TERMINAL BLOCK DETAILS FOR DISCONNECTOR CONTROL PANEL	STD-2451020	0	2 OF 2
7	GA OF MANUAL OPERATING MECHANISM FOR EARTH SWITCH	STD-2451021	0	1 OF 1
8	MECHANICAL INTERLOCK BETWEEN MAIN SWITCH & EARTH SWITCH	STD-2451022	0	1 OF 1
9	NAME PLATE DETAILS (FOR 245KV DBR DISCONNECTOR)	STD-2451023	0	1 OF 1
10	GTP FOR 245KV DBR DISCONNECTOR	STD/GTP/245KV/DBR	0	---

1. Minimum 300mm plinth shall be maintained for CT/PT/CVT/Isolators/IV/LA/Breakers in the substation during foundation works to ensure safe live to ground clearance per IE rules.
2. Since the supply of terminal connectors is not in the scope of manufacturer as mentioned in the drawings. The EPC contractor shall be instructed to supply the same line with CT/PT/CVT/Isolator/IVT/LA/Breaker's requirement and compatibility.

**CHIEF ENGINEER/PROJECTS
APTRANSCO/VISVIJAYAWADA**

DRN	YVG	07.07.23		SWITCHGEAR MANUFACTURING COMPANY	
CHKD	VK	07.07.23		GANDRAJUPALLE, CHITTOOR DIST, A.P, INDIA.	
APPD	OJA	07.07.23		TITLE	
DEPT	SIGN	DATE		FOR 245KV DBR DISCONNECTOR	
	SC: NTS	Paper size A3	DRG.NO. S T D - 2 4 5 1 0 1 5	SHEET 1 OF 1	REV. 0

NOTE:- THIS COMPLETE SET OF DRAWINGS ARE REPRESENTATIVE OF THE LATEST TYPE TEST REPORT AND PROPRIETARY DESIGN, RESEARCH & DEVELOPMENT OF SWITCHGEAR MANUFACTURING COMPANY PVT. LTD. GANDRAJUPALLE. THE DESIGNS SHALL NOT BE REPRODUCED WITHOUT WRITTEN CONSENT OF SWITCHGEAR MANUFACTURING COMPANY PVT. LTD. GANDRAJUPALLE.

NOTE:- THIS COMPLETE SET OF DRAWINGS ARE REPRESENTATIVE OF THE LATEST TYPE TEST REPORT AND PROPRIETARY DESIGN, RESEARCH & DEVELOPMENT OF SWITCHGEAR MANUFACTURING COMPANY PVT. LTD. GANDRAJAPALLE. THE DESIGNS SHALL NOT BE REPRODUCED WITHOUT WRITTEN CONSENT OF SWITCHGEAR MANUFACTURING COMPANY PVT. LTD. GANDRAJAPALLE.

DETAILS OF FIXED CONTACT

NOTE: 1. Drawings Approval subject to valid type test reports, to be checked during acceptance tests.
2. For EPC contractors only.

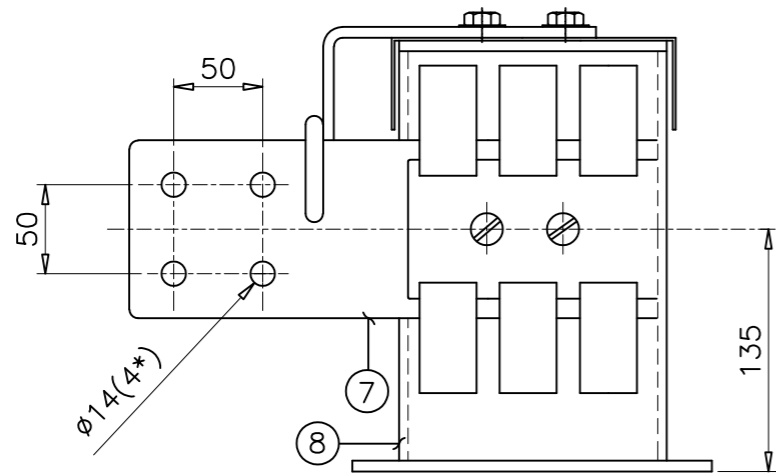

ELEVATION

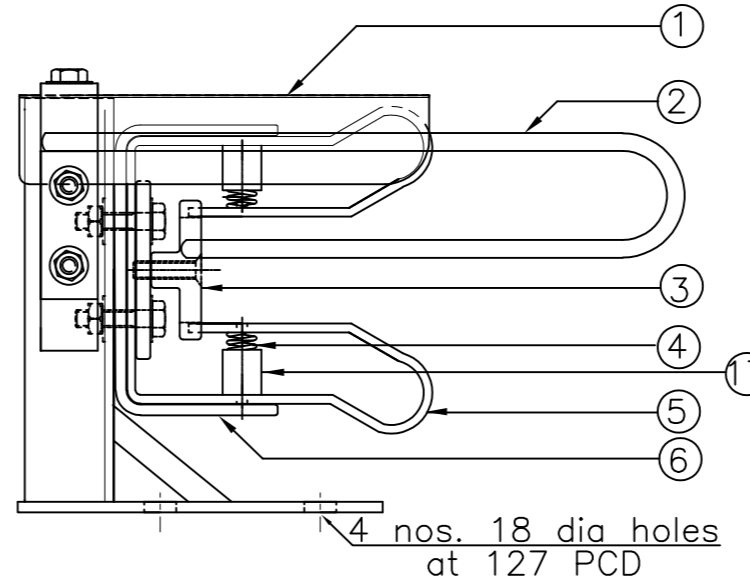

END VIEW

DETAILS OF MOVING CONTACT

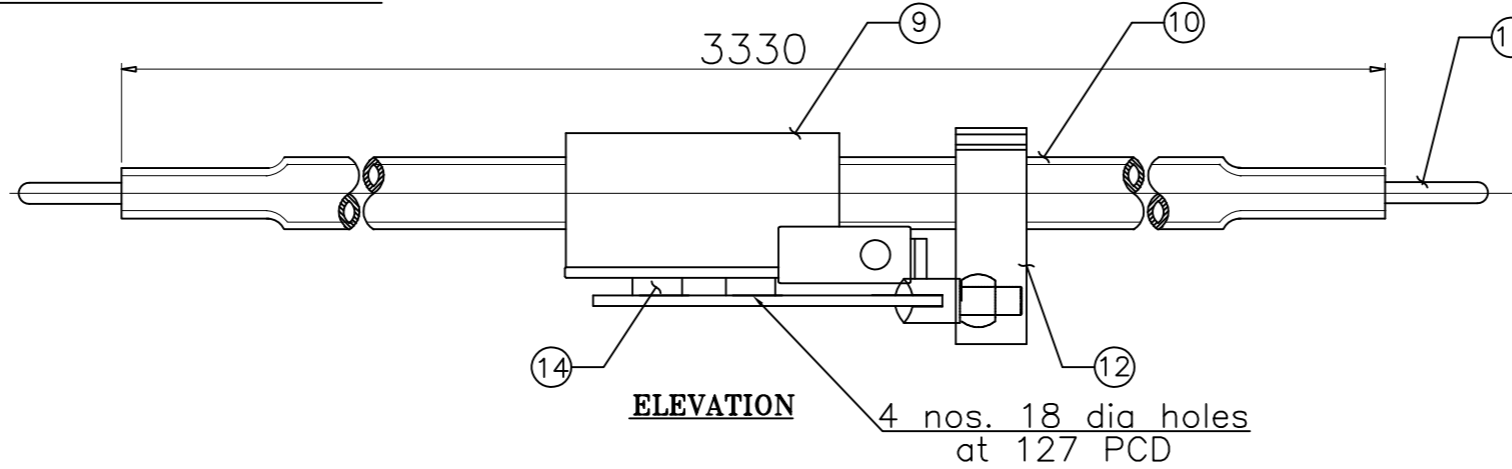

ELEVATION

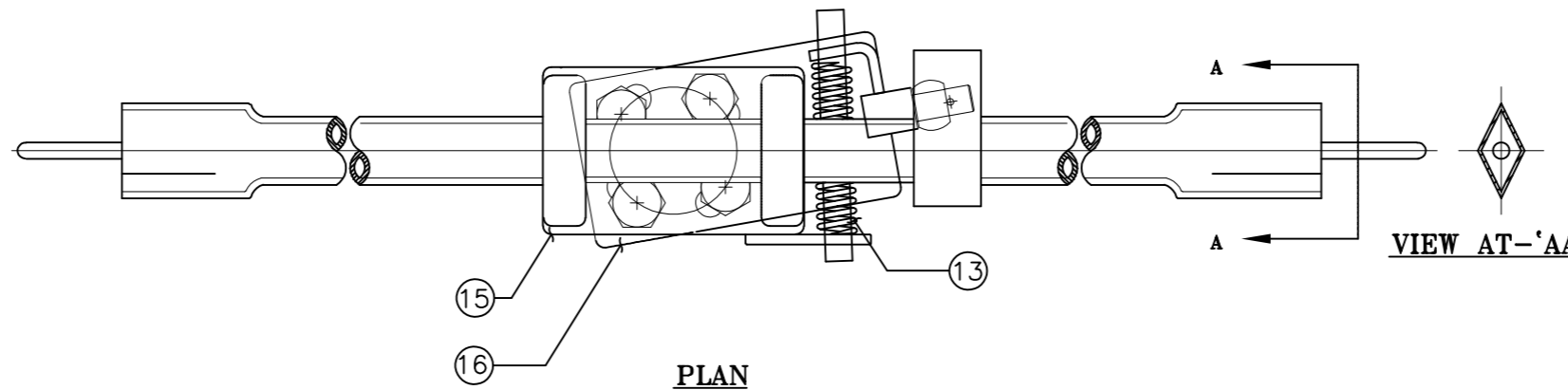

PLAN

VIEW AT-'AA'

**CHIEF ENGINEER/PROJECTS
APTRANSCO/VS/VIJAYAWADA**

Drawing approval subject to valid vendor registration

PART LIST

1. FC rain hood (AL.)
2. FC Arcing horn (MS HDG)
3. Spacer (AL.)
4. FC spring (SS)
5. FC Jaw (3 Nos. 32x4 HDE Cu.flat)
6. Jaw back strip (MS HDG)
7. Jumper pad (100x12 Al. flat)
8. Supporting channel (MS HDG)
9. MC Rain Hood (AL.)
10. MC arm (50 OD 41 ID Cu. tube)
11. MC Arcing horn (MS HDG)
12. MC Clamp (MS HDG)
13. MC Spring (SS)
14. Spacer Bush (BRASS)
15. MC top plate (MS HDG)
16. MC bottom plate (MS HDG)
17. Bush (plastic)

1. Minimum 300mm plinth shall be maintained for CT/PT/CVT/Isolators/IV/LA/Breakers in the substation during foundation works to ensure safe live to ground clearance per IE rules.
2. Since the supply of terminal connectors is not in the scope of manufacturer as mentioned in the drawings. The EPC contractor shall be instructed to supply the same line with CT/PT/CVT/Isolator/IVT/LA/Breaker's requirement and compatibility.

NOTES

1. All dimensions are in 'mm'
2. All ferrous parts are hot-dip galvanized with 85 microns
3. All non-ferrous contact points are silver plated with 15 microns
4. Tolerances

(i) Upto 50mm	---	+3%	(ii) 51 to 100 mm	---	+2%
(iii) 101 to 300mm	---	+1%	(iv) Above 300mm	---	+0.5%
5. Bolted area are Tin plated up to 10 microns to avoid bi-metallic reaction between Cu & Al

Sl.No.	Cross section	Area	Current Rating	Current Density (Amps/sq.mm)
1	(FC JAWS) 32X4X(3x2)	768mm ²	1200A	1.56
2	(MC ARM) 50 OD X 41 ID	642.91mm ²	1200A	1.86
3	JUMPER PAD (100X12)	1200mm ²	1200A	1

DRN	YVG	04.06.22
CHKD	VK	07.07.23
APPD	OJA	07.07.23
DEPT	SIGN	DATE
SC: NTS	Paper size	A3

SWITCHGEAR MANUFACTURING COMPANY GANDRAJUPALLE, CHITTOOR DIST, A.P, INDIA.		TITLE	
		MAIN CONTACT DETAILS (FOR 245KV 1200A DBR DISCONNECTOR)	
DRG.NO.	S T D -	2 4 5 1 0 1 7	SHEET 1 of 1
			REV. 0

			198
			765
REV	DATE	CHANGES MADE	SIG

NOTE:- THIS COMPLETE SET OF DRAWINGS ARE REPRESENTATIVE OF THE LATEST TYPE TEST REPORT AND PROPRIETARY DESIGN, RESEARCH & DEVELOPMENT OF SWITCHGEAR MANUFACTURING COMPANY PVT. LTD. GANDRAJAPALLE. THE DESIGNS SHALL NOT BE REPRODUCED WITHOUT WRITTEN CONSENT OF SWITCHGEAR MANUFACTURING COMPANY PVT. LTD. GANDRAJAPALLE.

NOTE: 1. Drawings Approval subject to valid type test reports, to be checked during acceptance tests.
 2. For EPC contractors only.

FIXED CONTACT DETAILS

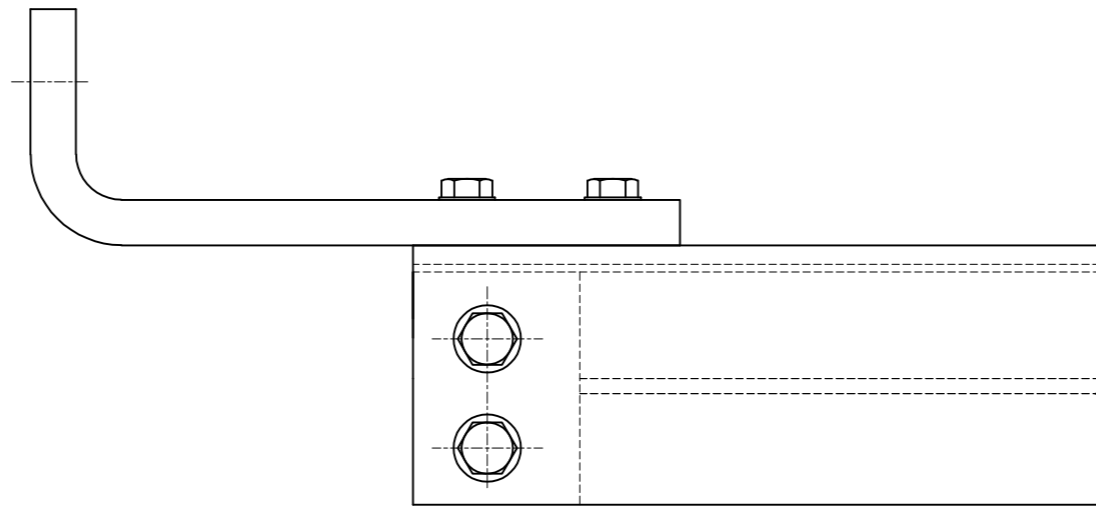

ELEVATION

Drawing approval subject to valid vendor registration

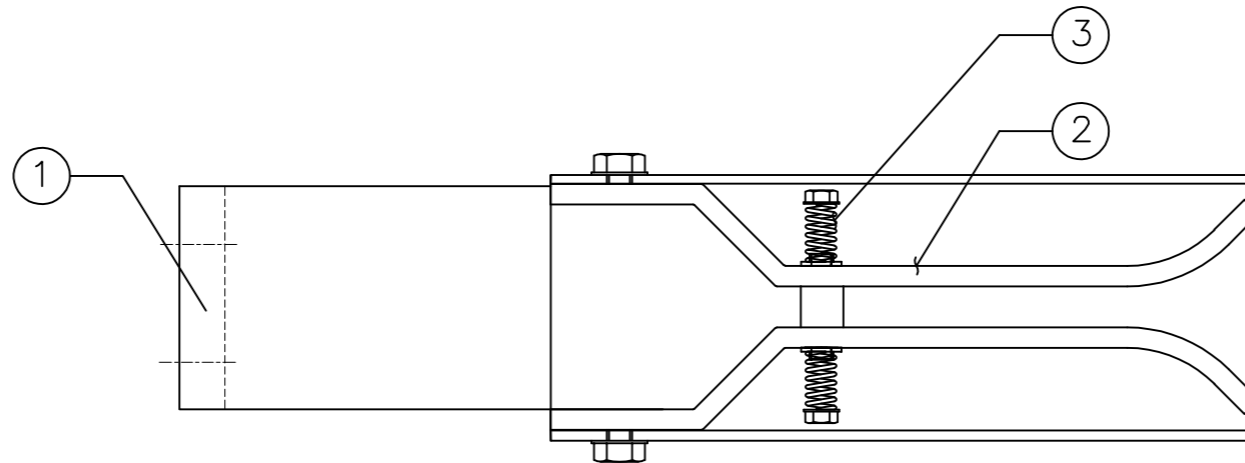

PLAN

CHIEF ENGINEER/PROJECTS
APTRANSCO/VS/VIJAYAWADA

MOVING CONTACT DETAILS

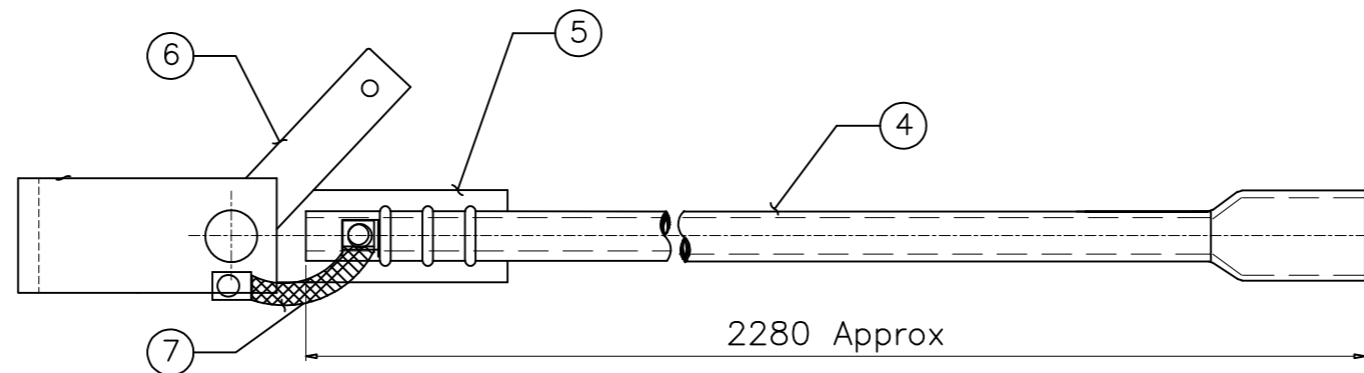

NOTES

1. ALL DIMENSIONS ARE IN 'MM'
2. ALL HDE COPPER CONTACT POINTS ARE SILVER PLATED WITH 15 MICRONS
3. MANUFACTURING TOLERANCES
 - i) UPTO 50mm-- ±3% ii) 51 to 100mm-- ±2%
 - iii) 101 to 300mm--±1% iv) ABOVE 300mm-- ±0.5%
- 4 BOLTED AREA ARE TIN PLATED UP TO 10 MICRONS TO AVOID BI-METALIC REACTION BETWEEN CU & AL

			199
			765
REV	DATE	CHANGES MADE	SIG

7	Copper braided flexible	Ø10mm Cu. rope, 5 Nos
6	MC Lever	MS HDG
5	MC Fixing plate	MS HDG
4	MC ARM	38 OD 30 ID Cu. Tube
3	FC Spring	SS
2	FC JAW	2 no's 50X5 Cu.flat
1	FC SUPPORTING STRIP	75X12 Al.
PT.	DESCRIPTION	
SL.NO	PART LIST	MATL

DRN	YVG	07.07.23	SWITCHGEAR MANUFACTURING COMPANY GANDRAJUPALLE, CHITTOOR DIST, A.P, INDIA.
CHKD	VK	07.07.23	
APPD	OJA	07.07.23	
DEPT	SIGN	DATE	
SC: NTS	Paper size	A3	TITLE EARTH SWITCH CONTACT DETAILS (FOR 245KV DBR DISCONNECTOR)
DRG.NO. S T D - 2 4 5 1 0 1 8			SHEET 1 of 1
			REV. 0

REV	DATE	CHANGES MADE	SIG

NOTE: 1. Drawings Approval subject to valid type test reports, to be checked during acceptance tests.
2. For EPC contractors only.

NOTE:- THIS COMPLETE SET OF DRAWINGS ARE REPRESENTATIVE OF THE LATEST TYPE TEST REPORT AND PROPRIETARY DESIGN, RESEARCH & DEVELOPMENT OF SWITCHGEAR MANUFACTURING COMPANY PVT. LTD. GANDRAJAPALLE. THE DESIGNS SHALL NOT BE REPRODUCED WITHOUT WRITTEN CONSENT OF SWITCHGEAR MANUFACTURING COMPANY PVT. LTD. GANDRAJAPALLE.

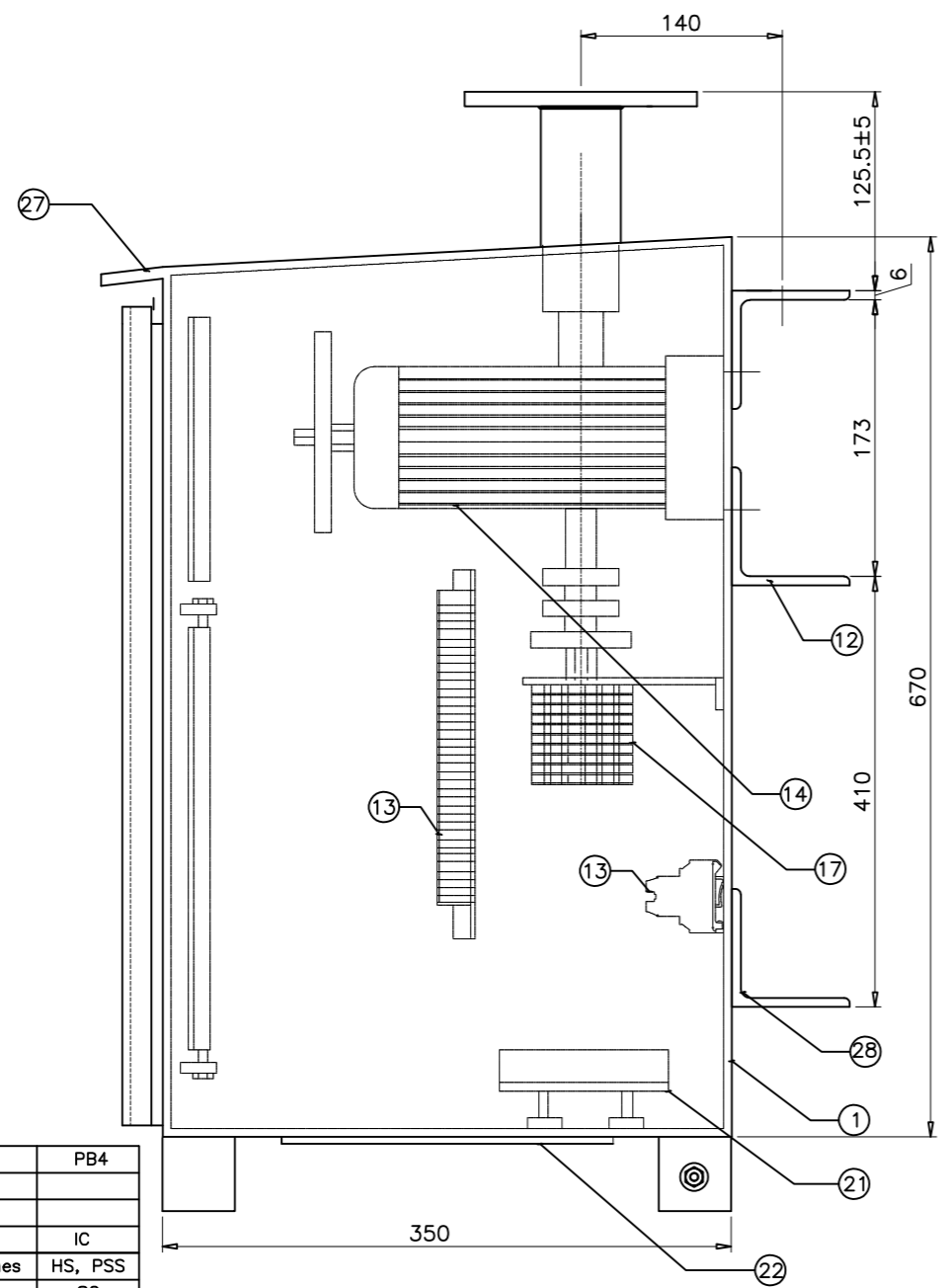

END VIEW

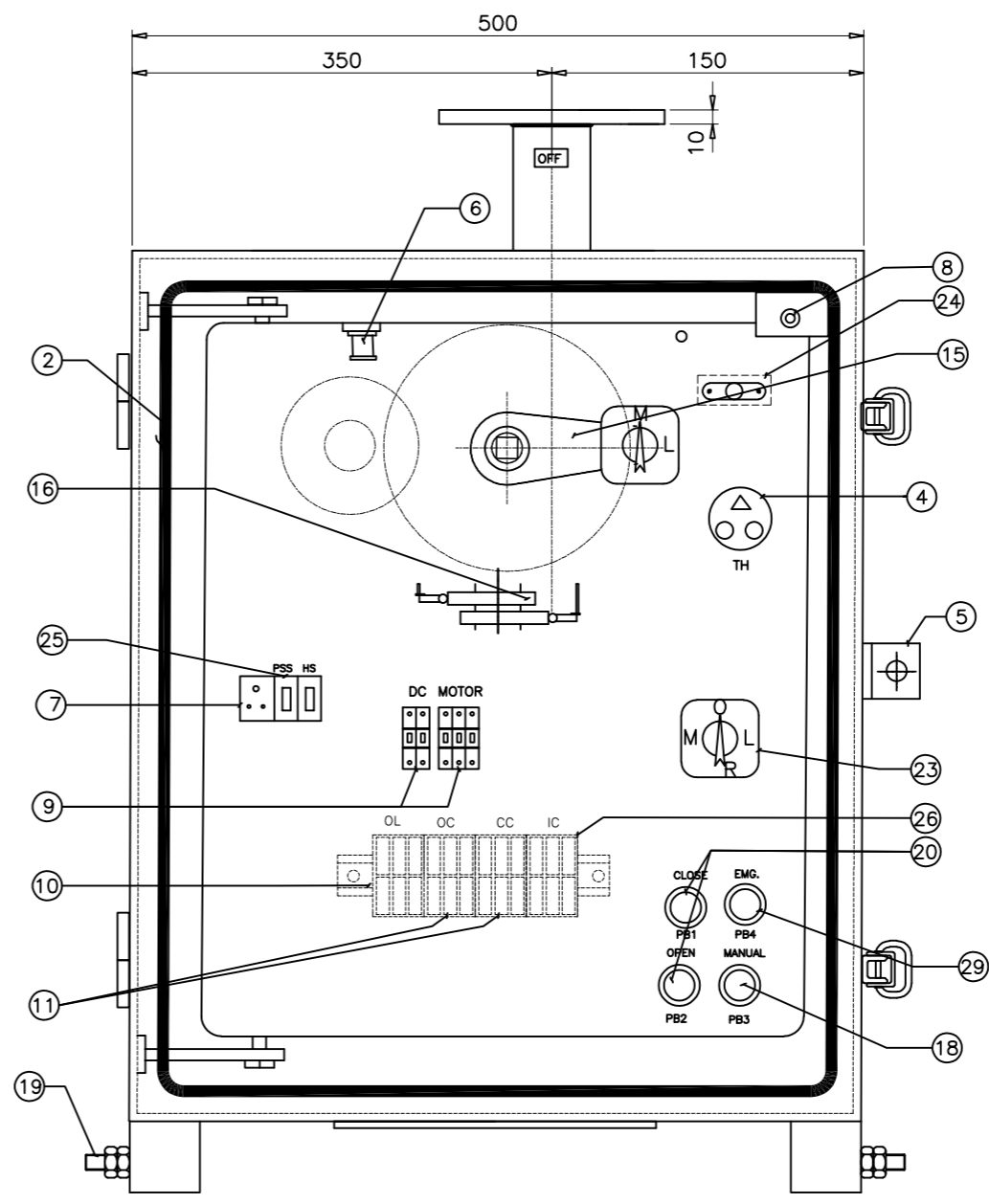

ELEVATION

**CHIEF ENGINEER/PROJECTS
APTRANSCO/VISVIJAYAWADA**

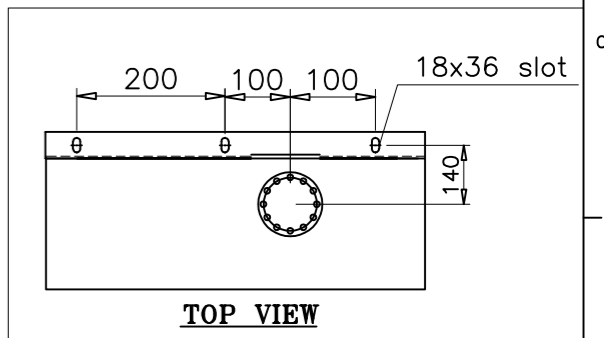

TOP VIEW

29	Emergency push button	PB4
28	Fixing cleat (Al.)	
27	Rain canopy	
26	Interlocking Contactor	IC
25	Heater & Power Socket Switches	HS, PSS
24	Solenoid Interlock	SC
23	Selector Switch (L/R/M)	S2
22	Gland plate (Without glands)	
21	Heater	CH
20	Close and open push buttons	PB1 & PB2
19	Earthing bolt (2nos of M12 size)	
18	Push buttons for manual	PB3
17	Aux. switch	
16	Limit switch	LS
15	Knob for manual operation	
14	Motor with reduction gear unit	
13	Terminal block(CTS4UN)	
12	Fixing Angle (MS HDG)	
11	Open & Close contactors	OC/CC
10	Overload relay (OL) cum SPP	OLR
9	MCBs	
8	Light switch (Door Operated)	
7	Power socket	PS
6	Lamp holder (WITHOUT LAMP)	CL
5	Provision for padlock	
4	Thermostat	TH
3	Handle for manual operation	
2	Rubber gasket (EPDM)	
1	Enclosure (3mm Th Aluminium)	
PT NO.	DESCRIPTION	LEGEND

Drawing approval subject to valid vendor registration

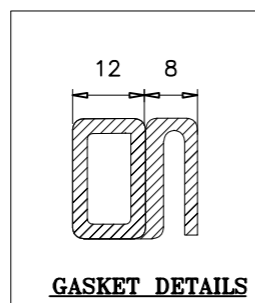

GASKET DETAILS

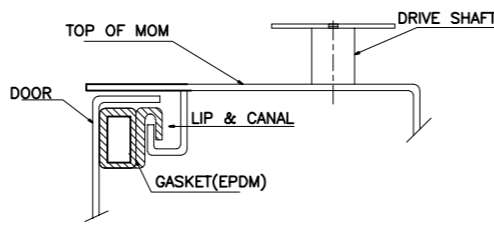

SECTIONAL VIEW OF DOOR GASKET

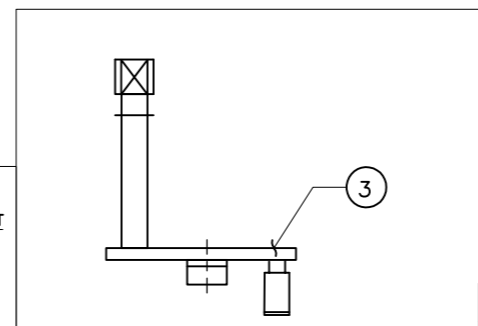

HANDLE FOR MANUAL OPERATION
(Kept on back of the door)

NOTES

- 01 All dimensions are in 'mm'
- 02 For manual operation follow the instructions as given in schematic diagram
- 03 Degree of protection for cabinet IP:55 as per IS:13947
- 04 Cubicle shall be made out of 3 mm thick Aluminium Sheet and painted to paint shade 631 of IS:5
- 05 Net weight of the box-70Kgs (Approx)
- 06 Internal wiring will be done with 2.5 sq.mm cu stranded conductor & 20% Spare Terminals shall be provided.
- 07 Tolerance as per GA drawing

DRN	YVG	07.07.23	SWITCHGEAR MANUFACTURING COMPANY GANDRAJAPALLE, CHITTOOR DIST, A.P, INDIA.
CHKD	VK	07.07.23	
APPD	OJA	07.07.23	
DEPT	SIGN	DATE	TITLE
SC: NTS	Paper size	A3	GENERAL ARRANGEMENT OF MOTOR OPERATING MECHANISM FOR DISCONNECTOR
DRG.NO. S T D - 2 4 5 1 0 1 9			SHEET 1 of 1
			REV. 0

REV	DATE	CHANGES MADE	SIG

NOTE: 1. Drawings Approval subject to valid type test reports, to be checked during acceptance tests.
2. For EPC contractors only.

NOTE:- THIS COMPLETE SET OF DRAWINGS ARE REPRESENTATIVE OF THE LATEST TYPE TEST REPORT AND PROPRIETARY DESIGN, RESEARCH & DEVELOPMENT OF SWITCHGEAR MANUFACTURING COMPANY PVT. LTD. GANDRAJAPALLE. THE DESIGNS SHALL NOT BE REPRODUCED WITHOUT WRITTEN CONSENT OF SWITCHGEAR MANUFACTURING COMPANY PVT. LTD. GANDRAJAPALLE.

AC CIRCUIT

415V, 3Ø, AC SUPPLY

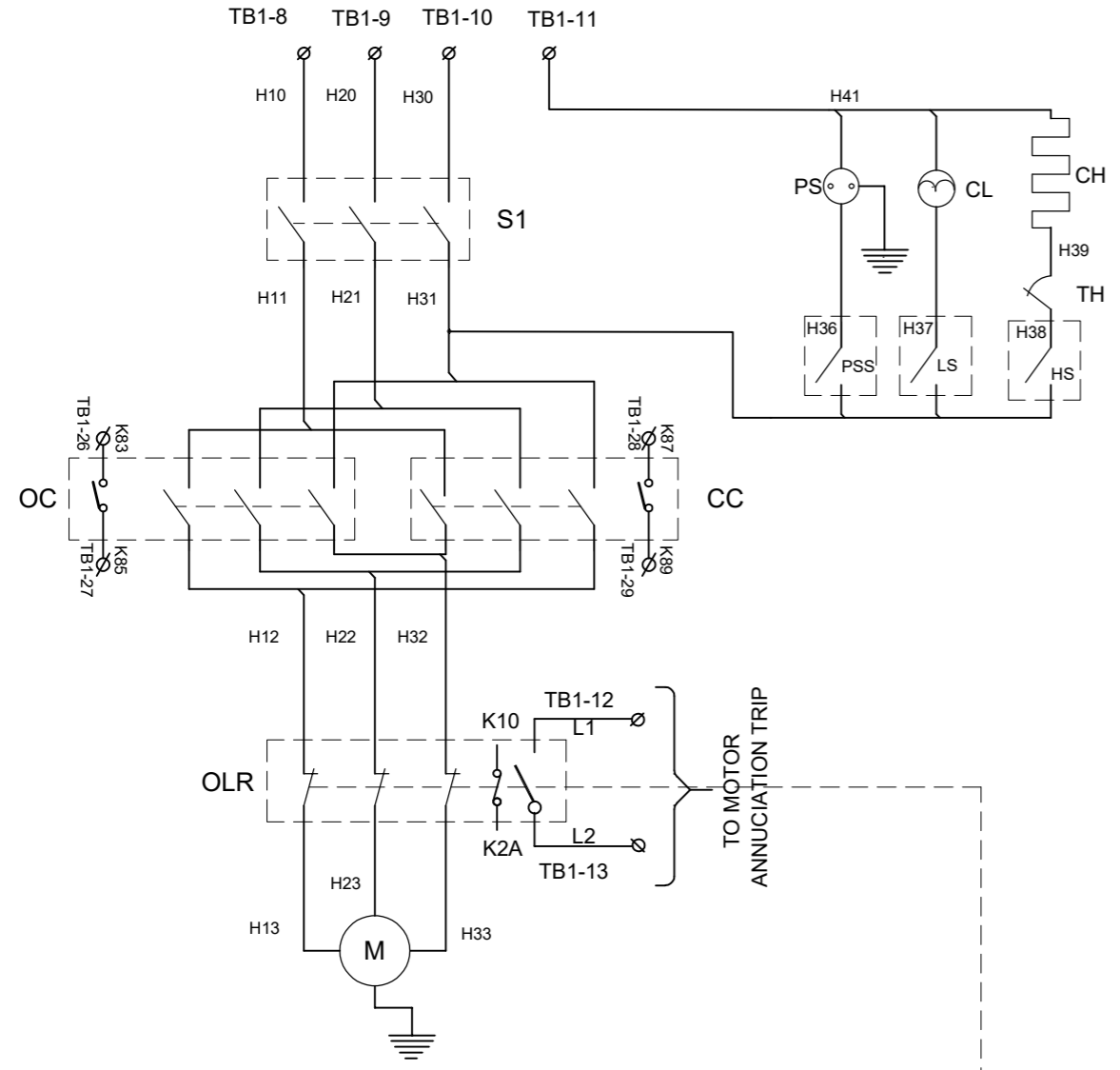

Drawing approval subject to valid vendor registration

DC CIRCUIT

220V DC SUPPLY

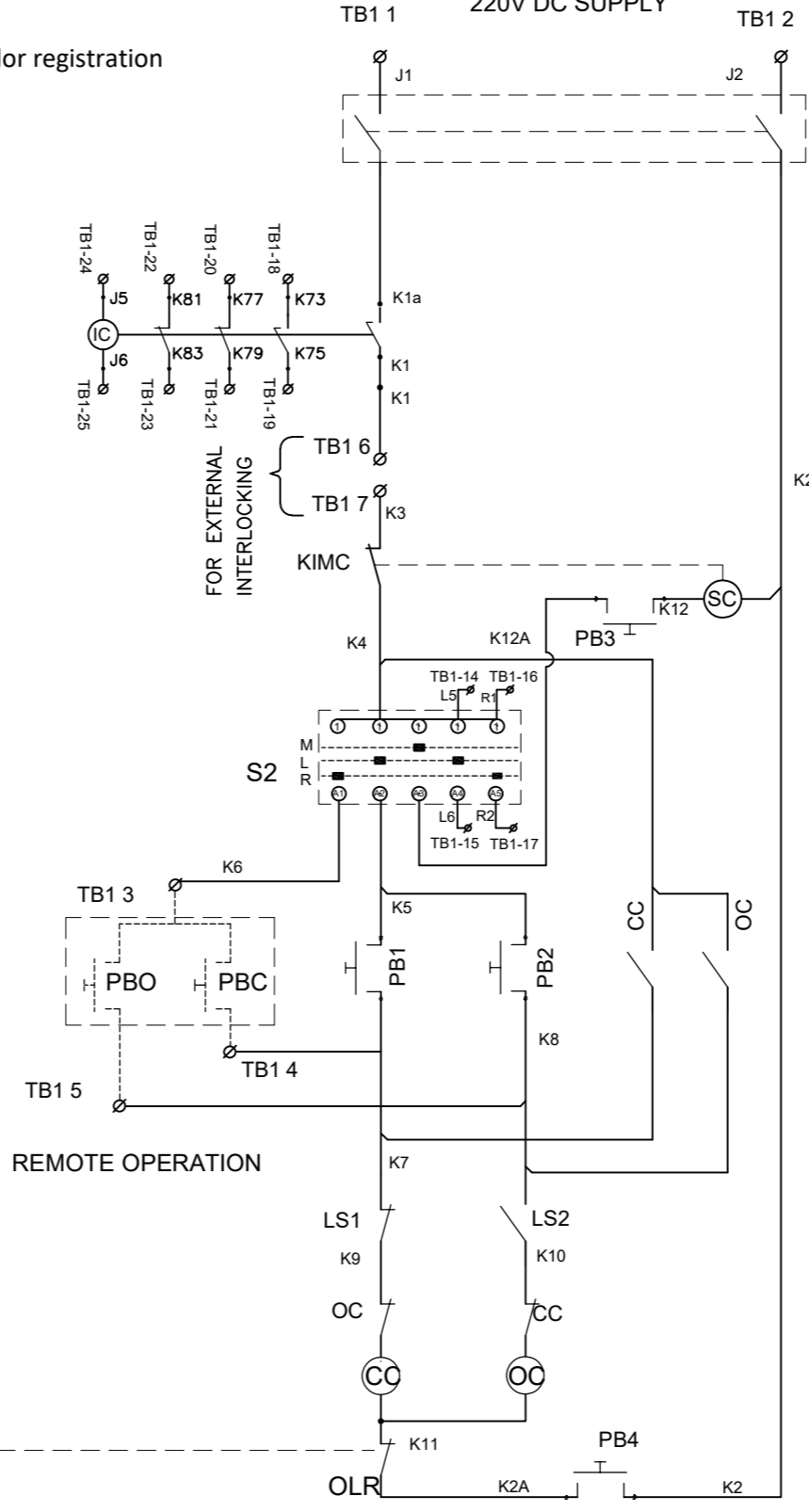

**CHIEF ENGINEER/PROJECTS
APTRANSCO/VS/VIJAYAWADA**

OPERATING INSTRUCTIONS

- 1 Operation is possible only when the breaker is in 'OPEN' condition and after interlocking condition of system are satisfied
- 2 For manual operation of isolator please follow the instructions given below:
 - i) Press the manual push button(PB3) & Rotate the knob(15) provided on panel board, due to which the blocking flap will rotate to gain access for manual operation
 - ii) Insert the operating handle through hole to the gear box shaft
 - iii) Rotate the handle clockwise/anti-clockwise for open/close the Disconnector
 - iv) When manual operation is not needed, restore the knob to its original position

NOTES

- 1) Scheme shown when Disconnector in open position & De-Energised
- 2) In case of unavailability alternate reputed make shall be used

PB4	Emergency push button	Siemens/Schneider/C&S/ABB/Teknic	1
IC	interlocking Contactor	Siemens/Schneider/C&S/ABB	1
KIMC	Key interlock switch	Recom/Kaycee/Switron	1
M	Motor 3Ø 415V AC (0.5HP)	Remi/Elcen/Lhp/Hindustan/CGL	1
S2	L/R/M selector switch	Recom/Kaycee/Switron	1
S1	MCB for 3Ø AC Supply (6A)	Siemens/Schneider/C&S/ABB	1
PSS	Power socket switch (5A)	Anchor/Maru/Reputed	1
PS	Power socket (5A)	Anchor/Maru/Reputed	1
PB3	Interlock push button (for manual)	Siemens/Schneider/C&S/ABB/Teknic	1
PB1,PB2	Close and open push buttons	Siemens/Schneider/C&S/ABB/Teknic	2
OLR	Over load relay cum SPP(1-1.6A)	Siemens/Schneider/C&S/ABB	1
TH	Thermostat (30'-85')	Girish ego/Reputed	1
LS2	Limit switch close	Jaibalaji/BCH/Elmex/Mani/Teknic	1
LS1	Limit switch open	Jaibalaji/BCH/Elmex/Mani/Teknic	1
LS	Lamp switch (2A)	Anchor/Maru/Suraj	1
SC	Solenoid interlocking coil (220V)	OWN	1
HS	Heater switch (5A)	Anchor/Maru/Reputed	1
CS	MCB for Control supply (2A)	Siemens/Schneider/C&S/ABB	1
CH	Cubicle heater (80W, 240V AC)	Girish ego/Reputed	1
CL	Cubicle lamp (without bulb) 5A	Anchor/Maru/Reputed	1
OC & CC	Close and open contactors	Siemens/Schneider/C&S/ABB	2
LEGEND	DESCRIPTION	MAKE	QTY

1. Minimum 300mm plinth shall be maintained for CT/PT/CVT/Isolators/IV/LA/Breakers in the substation during foundation works to ensure safe live to ground clearance per IE rules.
2. Since the supply of terminal connectors is not in the scope of manufacturer as mentioned in the drawings. The EPC contractor shall be instructed to supply the same line with CT/PT/CVT/Isolator/IVT/LA/Breaker's requirement and compatibility.

DRN	YVG	07.07.23
CHKD	VK	07.07.23
APPD	OJA	07.07.23
DEPT	SIGN	DATE
SC: NTS	Paper size	A3

SWITCHGEAR MANUFACTURING COMPANY GANDRAJUPALLE, CHITTOOR DIST, A.P, INDIA.	
TITLE SCHEMATIC DIAGRAM OF FOR DISCONNECTOR CONTROL PANEL-AC & DC	
DRG.NO. S T D - 2 4 5 1 0 2 0	SHEET 1 of 2
REV. 0	

REV	DATE	CHANGES MADE	SIG

NOTE: 1. Drawings Approval subject to valid type test reports, to be checked during acceptance tests.
2. For EPC contractors only.

Drawing approval subject to valid vendor registration

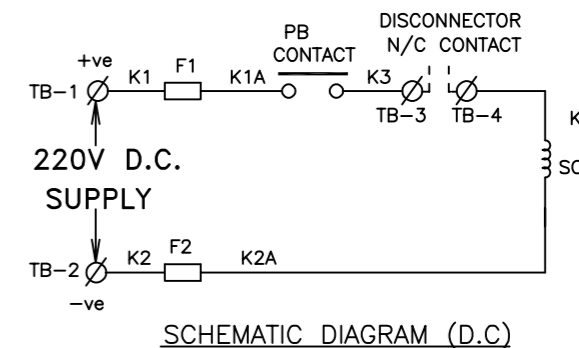
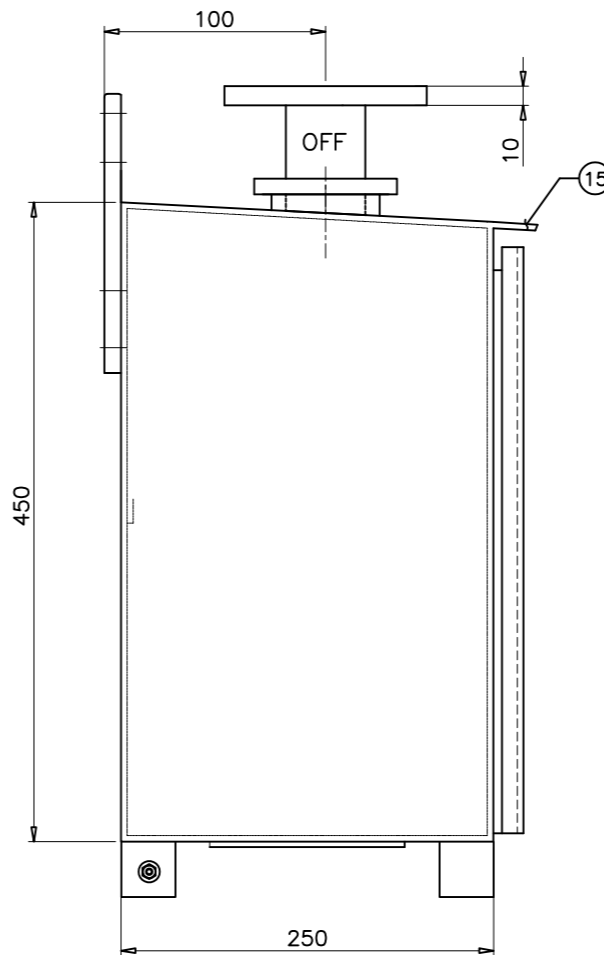
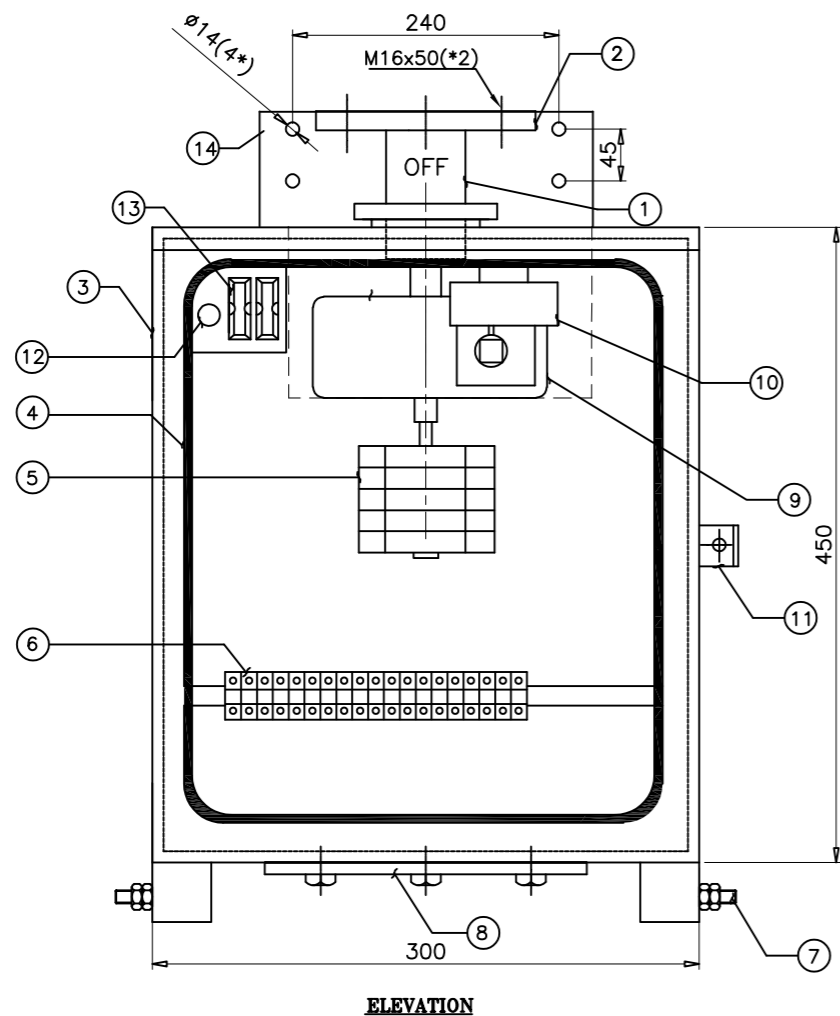

LEGEND
 F1, F2 : Fuses for control supply
 PB : Push button
 S.C. : Solenoid coil

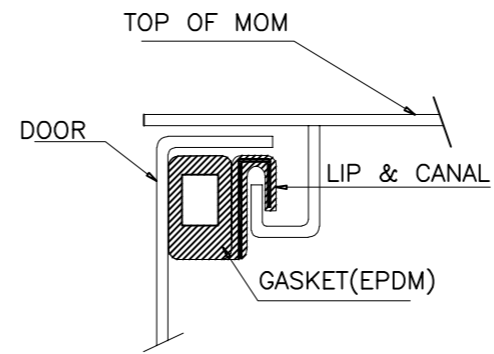
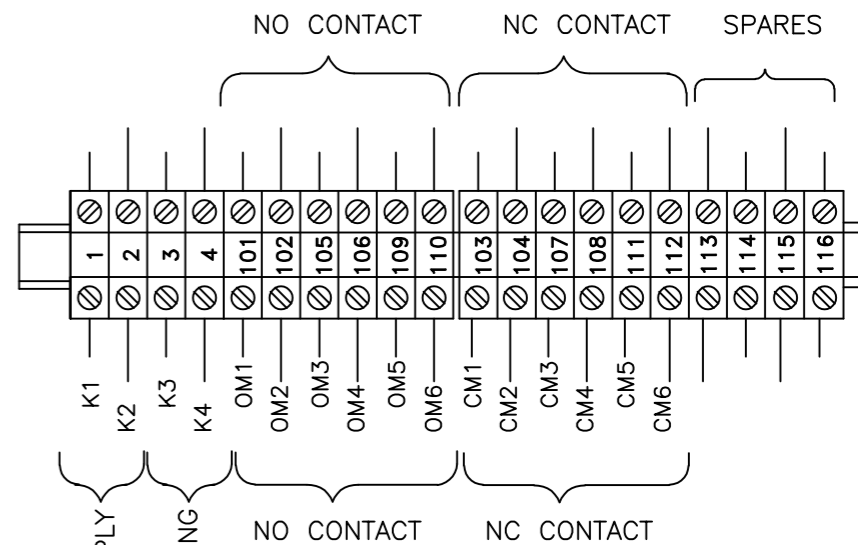

SECTIONAL VIEW OF DOOR GASKET

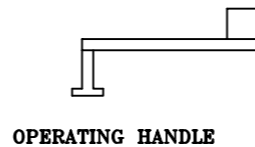

CHIEF ENGINEER/PROJECTS
APTRANSCO/VISVIJAYAWADA

PT.	DESCRIPTION
15	RAIN CANOPY
14	FIXING BRACKET (MS HDG)
13	FUSES FOR CONTROL SUPPLY
12	PUSH BUTTON
11	PROVISION FOR PADLOCK
10	Solenoid Coil
9	REDUCTION GEAR
8	CABLE GLAND FIXING PLATE (W/O GLANDS)
7	EARTH TERMINAL(2 nos. M10 size)
6	TERMINAL BLOCK (CTS 4UN)
5	AUXILIARY SWITCH
4	GASKET (EPDM RUBBER)
3	CUBICLE (3MM AL. SHEET)
2	FLANGE (14 HOLES)
1	OPERATING SHAFT

PART LIST

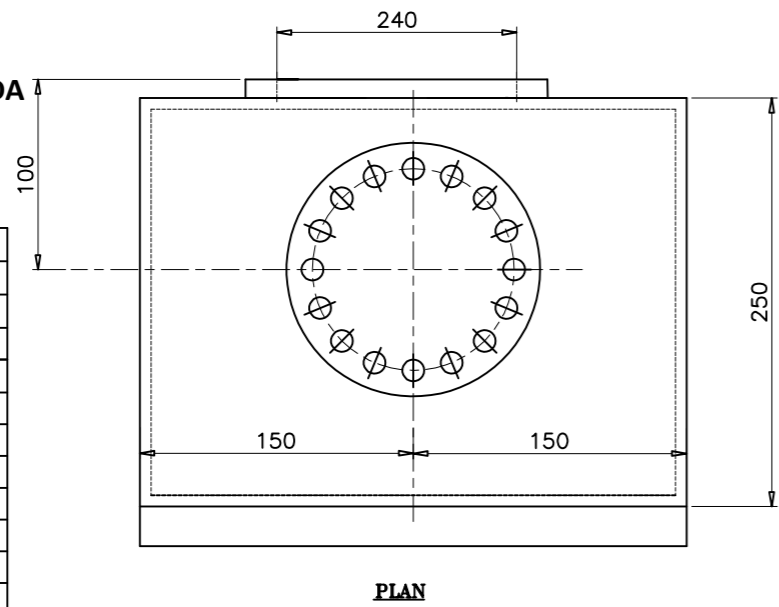

NOTES
 1. All dimensions are in 'mm'
 2. Cubicle will be painted to the shade no. 631 IS:5
 3. Always keep the drive in upright position
 4. Degree of protection :IP55
 5. Net weight of the box-28 Kgs(approx)
 6. Tolerances as per GA drawing
 7. Internal wiring will be done with 2.5 sq.mm cu. stranded conductor & 20% spare terminals will be provided

DRN	YVG	07.07.23	SWITCHGEAR MANUFACTURING COMPANY GANDRAJUPALLE, CHITTOOR DIST, A.P, INDIA.
CHKD	VK	07.07.23	
APPD	OJA	07.07.23	
DEPT	SIGN	DATE	
TITLE GENERAL ARRANGEMENT OF MANUAL OPERATING MECHANISM FOR EARTH SWITCH			SHEET 1 of 1
Paper size A3	DRG.NO. S T D - 2 4 5 1 0 2 1	REV. 0	

NOTE:- THIS COMPLETE SET OF DRAWINGS ARE REPRESENTATIVE OF THE LATEST TYPE TEST REPORT AND PROPRIETARY DESIGN, RESEARCH & DEVELOPMENT OF SWITCHGEAR MANUFACTURING COMPANY PVT. LTD. GANDRAJUPALLE. THE DESIGNS SHALL NOT BE REPRODUCED WITHOUT WRITTEN CONSENT OF SWITCHGEAR MANUFACTURING COMPANY PVT. LTD. GANDRAJUPALLE.

REV	DATE	CHANGES MADE	SIG

NOTE:- THIS COMPLETE SET OF DRAWINGS ARE REPRESENTATIVE OF THE LATEST TYPE TEST REPORT AND PROPRIETARY DESIGN, RESEARCH & DEVELOPMENT OF SWITCHGEAR MANUFACTURING COMPANY PVT. LTD. GANDRAJAPALLE. THE DESIGNS SHALL NOT BE REPRODUCED WITHOUT WRITTEN CONSENT OF SWITCHGEAR MANUFACTURING COMPANY PVT. LTD. GANDRAJAPALLE.

CASE- I
ISOLATOR IN CLOSED CONDITION & EARTH SWITCH IN OPEN CONDITION

CASE- II
ISOLATOR IN OPEN CONDITION & EARTH SWITCH IN OPEN CONDITION

CASE- III
ISOLATOR IN OPEN CONDITION & EARTH SWITCH IN CLOSED CONDITION

Drawing approval subject to valid vendor registration

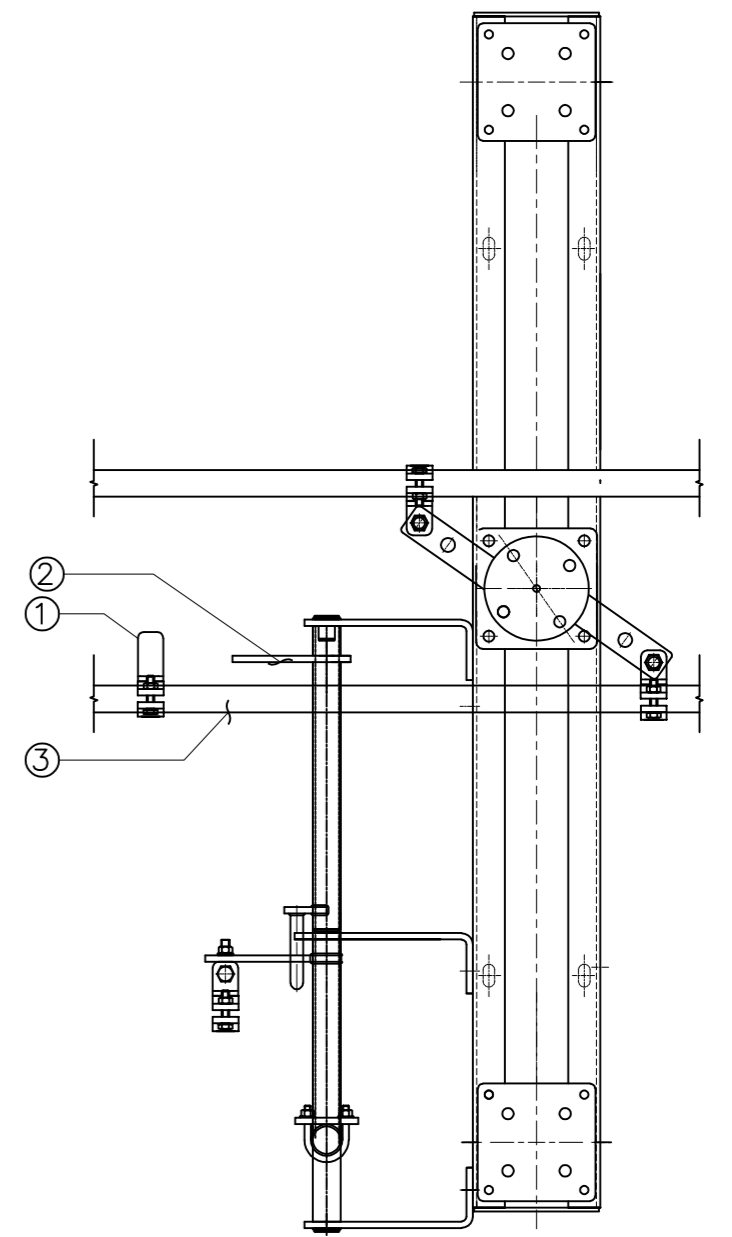
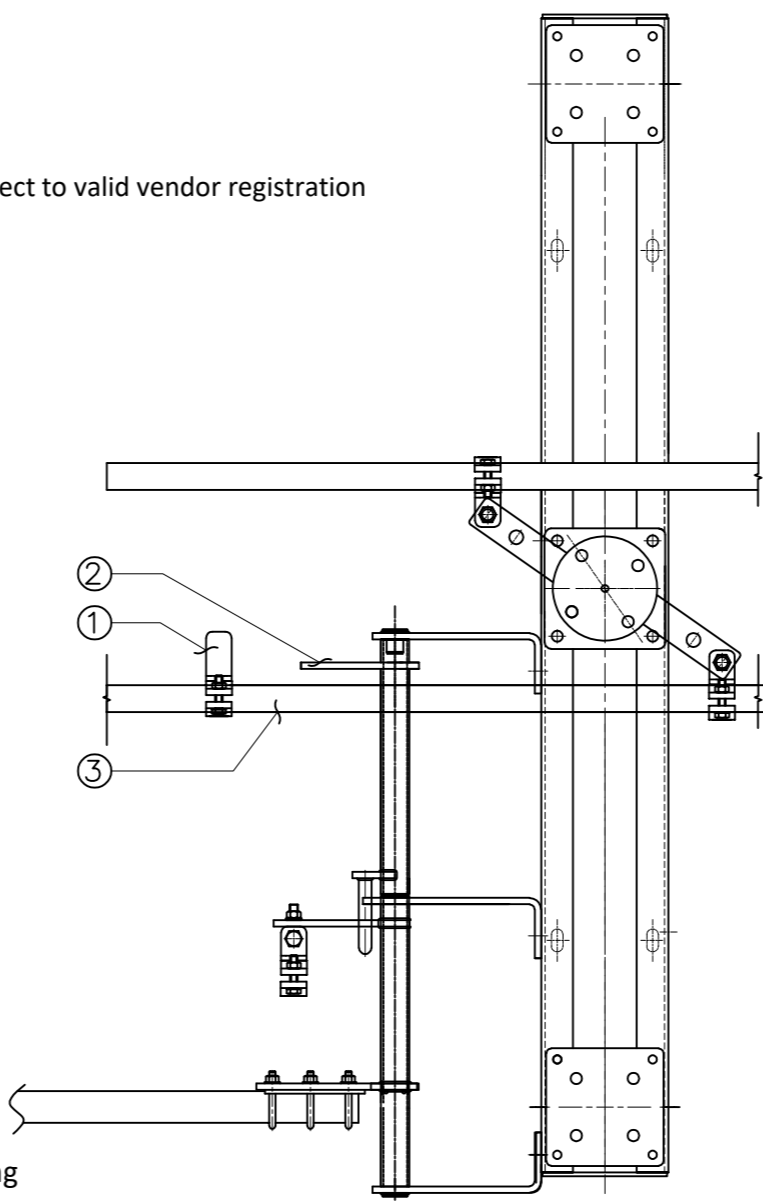
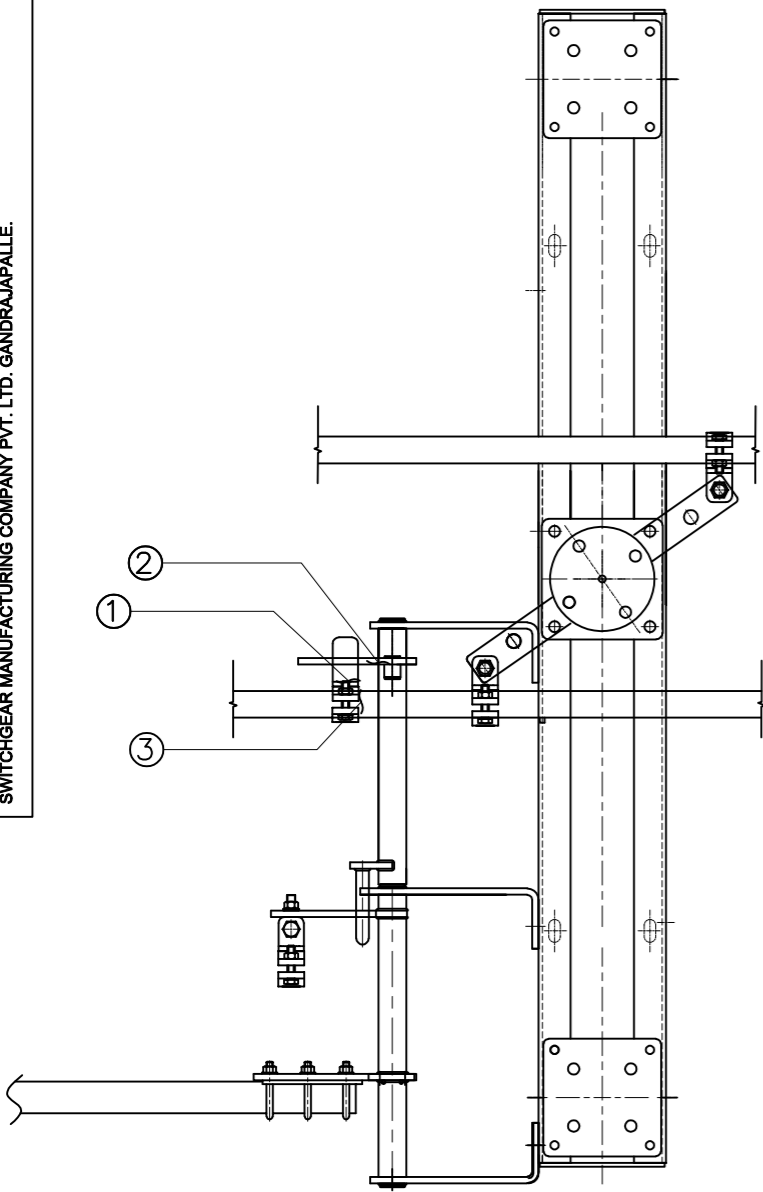

NOTE: 1. Drawings Approval subject to valid type test reports, to be checked during acceptance tests.
2. For EPC contractors only.

1. Minimum 300mm plinth shall be maintained for CT/PT/CVT/Isolators/IV/LA/Breakers in the substation during foundation works to ensure safe live to ground clearance per IE rules.
2. Since the supply of terminal connectors is not in the scope of manufacturer as mentioned in the drawings. The EPC contractor shall be instructed to supply the same line with CT/PT/CVT/Isolator/IVT/LA/Breaker's requirement and compatibility.

CHIEF ENGINEER/PROJECTS
APTRANSCO/VS/VIJAYAWADA

3. TANDEM PIPE (40 NB GI PIPE)	DRN	YVG	07.07.23	SWITCHGEAR MANUFACTURING COMPANY GANDRAJUPALLE, CHITTOOR DIST, A.P, INDIA.	
2. INTERLOCKING LEVER	CHKD	VK	07.07.23		
1. INTERLOCKING CLAMP	APPD	OJA	07.07.23		
S.NO	DESCRIPTION	DEPT	SIGN	DATE	TITLE MECH. INTERLOCK BETWEEN M/S & E/S FOR 245KV DBR DISCONNECTOR
	PART LIST	SC: NTS	Paper size A3	DRG.NO. S T D - 2 4 5 1 0 2 2	
				SHEET 1 of 1	REV. 0

NOTE:- THIS COMPLETE SET OF DRAWINGS ARE REPRESENTATIVE OF THE LATEST TYPE TEST REPORT AND PROPRIETARY DESIGN, RESEARCH & DEVELOPMENT OF SWITCHGEAR MANUFACTURING COMPANY PVT. LTD. GANDRAJUPALLE. THE DESIGNS SHALL NOT BE REPRODUCED WITHOUT WRITTEN CONSENT OF SWITCHGEAR MANUFACTURING COMPANY PVT. LTD. GANDRAJUPALLE.

			205
			765
REV	DATE	CHANGES MADE	SIG

NOTE: 1. Drawings Approval subject to valid type test reports, to be checked during acceptance tests.
 2. For EPC contractors only.

1. Minimum 300mm plinth shall be maintained for CT/PT/CVT/Isolators/IV/LA/Breakers in the substation during foundation works to ensure safe live to ground clearance per IE rules.
 2. Since the supply of terminal connectors is not in the scope of manufacturer as mentioned in the drawings. The EPC contractor shall be instructed to supply the same line with CT/PT/CVT/Isolator/IVT/LA/Breaker's requirement and compatibility.

80

SWITCHGEAR MANUFACTURING COMPANY
 GANDRAJUPALLE, CHITTOOR DIST, AP, INDIA

120

CUSTOMER	TRANSMISSION CORPORATION OF ANDHRA PRADESH LIMITED		
SL.No.	(*)	TYPE	DBR
VOLTAGE (kV)	245	CURRENT (Amps)	1200
STC (kA-sec-kAp)	40-3-100	IMPULSE (kVp)	1050
DC VOLTAGE (V)	220	PF VOLTAGE (kV)	460
OPERATING DEVICE	MOTOR	FREQUENCY (Hz)	50
YEAR	(*)		

FOR DISCONNECTOR

80

SWITCHGEAR MANUFACTURING COMPANY
 GANDRAJUPALLE, CHITTOOR DIST, AP, INDIA

120

CUSTOMER	TRANSMISSION CORPORATION OF ANDHRA PRADESH LIMITED		
SL.No.	(*)	TYPE	VB
VOLTAGE (kV)	245	DC VOLTAGE (V)	220
STC (kA-sec-kAp)	40-3-100	FREQUENCY (Hz)	50
OPERATING DEVICE	MANUAL	YEAR	(*)

FOR EARTH SWITCH

(**) TO BE MARKED AT THE TIME OF MANUFACTURING

Drawing approval subject to valid vendor registration

NOTE:

1. ALL DIMENSIONS ARE IN MM
2. MATERIAL : ALUMINIUM ALLOY
3. TOLERANCE AS PER GA DRAWING
4. LETTER ITCHED ON BLACK BACKGROUND

CHIEF ENGINEER/PROJECTS
APTRANSCO/VISVIJAYAWADA

DRN	YVG	07.07.23		SWITCHGEAR MANUFACTURING COMPANY	
CHKD	VK	07.07.23		GANDRAJUPALLE, CHITTOOR DIST, A.P, INDIA.	
APPD	OJA	07.07.23		TITLE	
DEPT	SIGN	DATE		NAME PLATE DETAILS FOR 245KV DBR DISCONNECTOR	
	SC: NTS	Paper size A3	DRG.NO. S T D - 2 4 5 1 0 2 3	SHEET 1 of 1	REV. 0

7653965/2023/EEMRT-ENE51

2.For EPC contractors only.

SWITCHGEAR MANUFACTURING COMPANY PVT. LTD

CUSTOMER	:	TRANSMISSION CORPORATION OF ANDHRA PRADESH LIMITED
----------	---	--

GUARANTEED TECHNICAL PARTICULARS FOR 245kV DOUBLE BREAK DISCONNECTOR

SL. No	Description	Unit	Particulars
1.	Manufacturer's Name & Address of manufacture		Switchgear Manufacturing Company Pvt. Ltd, Gandrajupalle, ChittoorDist
2.	Type Designation		Horizontal Double Break, DBR
3.	Applicable Standard CHIEF ENGINEER/PROJECTS		IS: 9921 (Part I to V) / IEC: 62271-102
4.	Rated voltage APTRANSCO/VS/VIJAYAWADA		245
5.	Rated Frequency	(Hz)	50
6.	Outdoor / Indoor		Outdoor
7.	Whether all three poles are ganged together mechanically / electrically		Mechanically ganged
8.	Rated normal current		
	a) Under normal condition as per IS/ IEC	(Amps)	1200Amps
	b) Under site conditions	(Amps)	1200
9.	Rated short time withstand current for 3 sec. for Isolator & Earth switch	(kA rms)	40
10.	Rated peak withstand short circuit current for Isolator & Earth switch	kAp	100
11.	Rated short circuit making current	KA	For No-load operated Isolator making current is not applicable. But shall carry peak short circuit current of 100kAp
12.	Rated Magnetizing current / Capacitive current make/break capacity at 0.15% p.f.	(Amp)	0.7 Amps at 0.15 Pf (Assigned value)
13.	Temperature rise over ambient temperature 50°C at site corresponding to		
	a) Maximum continuous current	(° C)	Within 55 °C
	b) Short time current	(° C)	
14.	Rated Insulation level		
	a) 1.2/50 microsecond lightning impulse withstand voltage (+ve or -ve polarity)		
	i) To earth	KV(peak)	± 1050
	ii) Across the open Isolator	KV(peak)	
	- One terminal lightning Impulse		± 1200
	- Opposite terminal power frequency		Not Applicable
	b) 250 / 2500 microsecond switching impulse withstand voltage		
	i) To earth	KV(peak)	Not Applicable
	ii) Across the open Isolator		
	- One terminal lightning Impulse	KV(peak)	Not Applicable
	- Opposite terminal power frequency	KV(peak)	Not Applicable
	c) One minute power frequency withstand voltage		
	i) To earth	KV (rms)	460
	ii) Across the terminals of open Isolator	KV (rms)	530
15.	Corona extinction voltage	KV (rms)	156
16.	Radio Interference voltage at 0.5 MHz and 2 MHz at 156 kV (rms)	(micro-volt)	1000 mV at 156 kV (rms)
17.	Rated mechanical terminal loads		
	a) Longitudinal (or straight)	N	800
	b) Transverse (or cross)	N	270

7653965/2023/EEMRT-ENE51

2.For EPC contractors only.

SWITCHGEAR MANUFACTURING COMPANY PVT. LTD

CUSTOMER		: TRANSMISSION CORPORATION OF ANDHRA PRADESH LIMITED	
18.	Total operating time		
	a) Opening time of Isolator	(Sec.)	12 sec. or less
	b) Closing time of Isolator	(Sec.)	12 sec. or less
19.	Main contacts (Fixed and Moving) of Isolator & Earth switch		
	a) Type		Main switch: High Pressure, Reverse Loop, Pressure relieving Type with Turn & Twist Design Earth switch: Slide-in-contact
	b) Material		Hard Drawn Electrolytic copper (HDEC)
	c) Whether contacts silver plated		Yes (Contact surface)
	d) Thickness of silver coating	microns	15 microns
	e) Contact area	mm ²	Line Contact
	f) Contact pressure	(Kg/ mm ²)	4kg/cm ² per Finger
	g) Current density(at minimum cross section of switch blade)		
	(i) Moving blade (Cu)	A/mm ²	1.86
	(ii) Terminal pad (Al)	A/mm ²	1
	(iii) Contacts (Cu)	A/mm ²	1.56
	(iv) Terminal connectors (Al)(Contractor scope)	A/mm ²	1.0
	h) No. of operations which the Isolator can make without deterioration of contacts	Nos.	1000 (min)
20.	AUXILIARY CONTACTS		
	a) MAIN ISOLATOR		
	(i) Total number of 'NO'(for Purchaser's use)	Nos.	8
	(ii) Total number of 'NC'(for Purchaser's use)	Nos.	8
	(iii) Rated voltage	(Volts)	220V DC
	(iv) Rated continuous current	(Amps)	10A
	(v) Rated breaking current	(Amps)	2A DC
	b) EARTH SWITCH		
	(i) Total number of 'NO'(for Purchaser's use)	Nos.	3
	(ii) Total number of 'NC'(for Purchaser's use)	Nos.	3
	(iii) Rated voltage	(Volts)	220V DC
	(iv) Rated continuous current	(Amps)	10A
	(v) Rated breaking current	(Amps)	2A DC
	c) Whether arcing contacts provided, and if so, and material used		Yes, M.S. Rod Hot-dip Galvanized
21.	Minimum clearance in air:		
	a) Phase to Phase clearance	mm	4500 (Center to Center)
	b) Phase to Ground clearance	mm	2300(Equal to the height of insulator selected)
	c) Between phases when isolator is open:	mm	3200(Center to Center)
22.	Bearings		
	a) Types of bearings		Deep Groove ball bearing
	b) Locations of bearings		Below the rotating post insulator
	c) Type of lubricant for bearings		Heavy Duty Grease

CHIEF ENGINEER/PROJECTS
APTRANSCO/VISVIJAYAWADA

Drawing approval subject to valid vendor registration

acceptance tests.

7653965/2023/EEMRT-ENE51

2. For EPC contractors only.

SWITCHGEAR MANUFACTURING COMPANY PVT. LTD

CUSTOMER	:	TRANSMISSION CORPORATION OF ANDHRA PRADESH LIMITED
----------	---	--

23.	Terminal Clamp & Connectors		Not in scope of Switchgear Manufacturing Company
	a) Manufacturer's Name		
	b) Applicable standard		
	c) Material		
	i. Clamp body		
	ii. Bolts & nuts		
	iii. Spring washers		
	d) Rated current	Amp	
	e) Rated terminal load	Kg.	
	f) Weight of clamp complete with hard ware	Kg.	
	g) Radio interference voltage	(micro-volts)	
	h) Corona extinction voltage	kV	
	i) Maximum allowable span for Aluminum Tube with outer diameter of 114.2 mm and inside diameter of 97.18 mm on equipment terminal and with rated fault current and 7 m & 4.5 m phase to phase spacing		CHIEF ENGINEER/PROJECTS APTRANSCO/VS/VIJAYAWADA
24.	Operating Mechanism		
	a) Name & address of manufacturer		Switchgear Manufacturing Company Pvt. Ltd, Gandrajupalle, Chittoor Dist
	b) Type of operating mechanism		Main switch: Motor with Manual Handle for Emergency operation Earth switch: Manual
	c) Whether separate operating mechanism provided for operation of Isolator pole and earthing switch.		Yes
	d) Electrical operation.		
	i) Motor type (AC / DC)		3 Phase, 415 V, 50 Hz, Squirrel Cage AC Induction motor
	ii) Applicable standard		IS : 325 & IS : 996
	iii) Rated - voltage and current, HP		415 Volt, 1.12 Amps, 0.5 H.P
	iv) Type of enclosure and method of cooling		Totally enclosed, self ventilating
	v) Power required for closing and opening operation	Watts	373
	vi) Running time for motor for closing and opening operation	(sec.)	Less than 12 secs
	vii) Control supply for motor (volt), power, consumption	Volt, Amp	220 Volt DC 35 Watts
	e) Type of manual operating mechanism for Isolator pole and earth switch.		Main switch: Reduction gear for smoothly controlled movement during the entire operation cycle. Earth switch: Manual with Reduction Gear
	f) Force required to operate		30 Kg-m.
	g) Whether padlocking are in included as per the specification		Provision is made
	h) Type of manual device		Torsional
	i) Weight of operating mechanism (Approx.)	kg	Motor Operating Mechanism Box - - 70kg Manual Operating mechanism Box – 28kg (Approx)
25.	Type of interlocking between isolator and earthing switch		

Drawing approval subject to valid vendor registration

7653965/2023/EEMRT-ENE51

SWITCHGEAR MANUFACTURING COMPANY PVT. LTD

CUSTOMER	:	TRANSMISSION CORPORATION OF ANDHRA PRADESH LIMITED	
a) Resistance of operating and Interlock coils		kΩ	2
b) Details of following interlocks provided as per specification			
i) Mechanical interlock between Isolator and earth switch			Yes
ii) Electrical interlock for Isolator and earth switch			Yes
iii) Electrical interlocking in association with circuit breaker			Yes
iv) Electrical interlock to bring back all three poles to open position in case any pole fails to close within specified time.			No
v) Provisions to cut-off supply to the motor during manual operation and provision for de-coupling the motor.			Yes
vi) Electrical scheme to provide remote alarm for pole discrepancy			No
vii) Arrangement provided to prevent electrical or manual operation unless interlock is satisfied.			Yes
26. Control Cabinet / Marshalling box/MOM Panel			
a) Name & address of Manufacturer			Switchgear Manufacturing Company Pvt. Ltd, Gandrajupalle, ChittoorDist
b) Applicable Standard			IS: 5039 / IS: 8623, IEC: 60439
c) Sheet thickness (mm) Top/Bottom/Side//Back/Door Leaf		mm	Aluminium, 3mm thick
d) Degree of protection provided			IP - 55
e) Colour of finish paint			
i) Outside			Light Admiral Grey in accordance with shade No. 631 of IS: 5
ii) Inside			
f) Control wiring			
(i) Current & Voltage rating		A, V	10 A & 1100 V
(ii) Size and Material of conductor			2.5 sq.mm Stranded copper wires
g) Terminal blocks			
(i) Name & address of Manufacturer			Elmex or connectwell
(ii) Current & Voltage rating		A, V	10 A & 1100 V
h) Space heater rating at 240 volts		(Watts)	80 watts
i) Provision of lock with keys		Yes/No	Yes
j) Dimensioned drawing (External & Internal)		Yes/No	Yes
k) Control cabinet / marshaling Box internal lighting lamp and door switch for controlling.			Provision for Bulb Holder and control by Door Switch shall be provided. Suitable Bulb shall be provided by Contractor
l) Weight		kg	70 Kgs (Approx.)
m) Plinth Mounted / Structure mounted.			Structure Mounted

Drawing approval subject to valid vendor registration

CHIEF ENGINEER/PROJECTS
APTRANSCO/VS/VIJAYAWADA

7653965/2023/EEMRT-ENE51

2. For EPC contractors only.

SWITCHGEAR MANUFACTURING COMPANY PVT. LTD

CUSTOMER	:	TRANSMISSION CORPORATION OF ANDHRA PRADESH LIMITED
----------	---	--

27.	A. Tandem Pipe		
	a) Size		32NB
	b) Class		Class 'B'
	c) Material		G.I. Pipe
	d) Applicable Standard		IS: 1239 (Part I), 1990 & IS: 4736, 1986
	e) Weight of Zinc	(gm/sq.m ²)	360
	B. Down Pipe		
	a) Size (Internal / External dia)	(mm)	50NB
	b) Class		Class 'B'
	c) Material		G.I. Pipe
	d) Applicable Standard		IS: 1239 (Part I), 1990 & IS: 4736, 1986
	e) Weight of Zinc	(gm/sq.m ²)	360
28.	Size and Weight		
	a) Weight of each pole (without Insulators)	Kgs. (Approx.)	Please refer GA drawing
	b) Space requirement i.e. length		
	c) Dimensions		
	(i) 3 Phase Isolator		
	(ii) Isolator -cum-Earthing Switch (mm x mm x mm)	mm	
	d) Size of largest part		
29.	INSULATORS		Not in scope of Switchgear Manufacturing Company

For Switchgear Manufacturing Company Pvt. Ltd

Authorized Signatory

Drawing approval subject to valid vendor registration

**CHIEF ENGINEER/PROJECTS
APTRANSCO/VISVIJAYAWADA**

1. Minimum 300mm plinth shall be maintained for CT/PT/CVT/Isolators/IV/LA/Breakers in the substation during foundation works to ensure safe live to ground clearance per IE rules.
2. Since the supply of terminal connectors is not in the scope of manufacturer as mentioned in the drawings. The EPC contractor shall be instructed to supply the same line with CT/PT/CVT/Isolator/IVT/LA/Breaker's requirement and compatibility.