

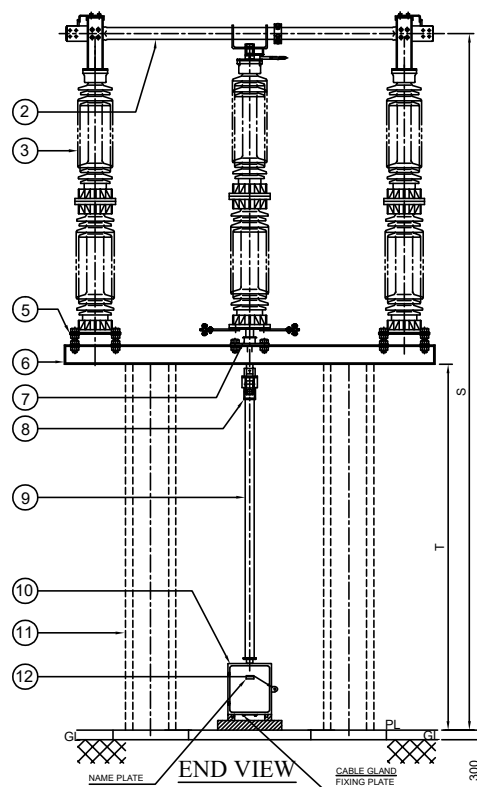

NOTE: 1. DRAWING APPROVAL SUBJECT TO VALID TYPE TEST REPORTS, TO BE CHECKED DURING ACCEPTANCE TESTS  
2. FOR EPC CONTRACTS ONLY

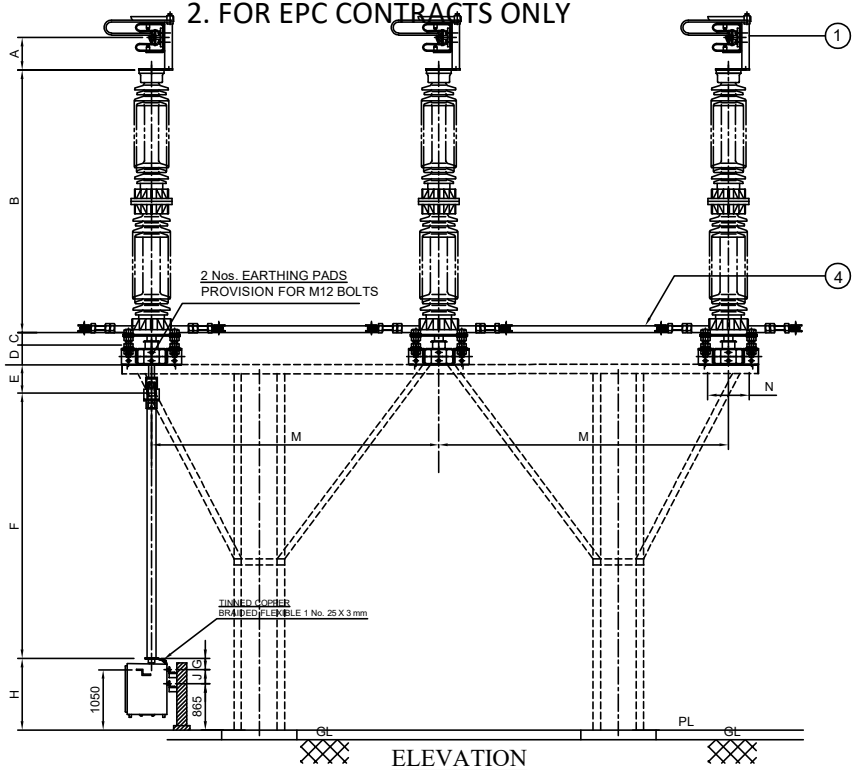

PART LIST:

1. FIXED CONTACT ASSEMBLY
2. MOVING CONTACT ASSEMBLY
3. INSULATOR STACK (NOT IN OUR SCOPE OF SUPPLY)
4. TANDEM PIPE (32 NB, G.I. PIPE)
5. ELEVATOR PLATE (12 mm THICK )
6. BASE CHANNEL (150 x 75 x 5 mm THICK MS CHANNEL)
7. ROTATING SHAFT WITH LEVER ARM & CLAMP (M.S. HOT DIP GALVANIZED)
8. UNIVERSAL JOINT ARRANGEMENT
9. DOWN OPERATING PIPE (50 NB, G.I. PIPE)
10. OPERATING MECHANISM FOR M.S. (MOTOR)
11. SUPPORTING STRUCTURE (NOT IN OUR SCOPE OF SUPPLY)
12. PROVISION FOR PADLOCK

316 Q

- 6 Nos.
- 3 Nos.
- 9 Nos.
- 2 Nos.
- 6 Nos.
- 3 Nos.
- 3 Nos.
- 1 No.
- 1 No.
- 1 No.
- 1 Set.
- 1 No.

REFERENCE DRAWINGS:

- FOR ISOLATOR CONTACT DETAILS (2000A) ----- 4. GRM APT 02  
 FOR OPERATING MECHANISM DETAILS (M.S.)----- 4. GM APT 03  
 FOR SCHEMATIC DIAGRAM DETAILS (M.S.) ----- 4. GM APT 04  
 FOR NAME PLATED DETAILS----- 4. GZ APT 05

Thickness of Silver plating : 15 Microns Minimum

NOTES:

1. ALL DIMENSIONS ARE IN MILLIMETERS
2. ALL FERROUS PARTS ARE HOT DIP GALVANIZED (87 MICRONS)
3. ALL NON-FERROUS CONTACT POINTS ARE SILVER PLATED (15 MICRONS)
4. THE INDICATED DIMENSIONS ARE SUBJECT TO THE MANUFACTURING TOLERANCE:  
 UP TO 50 mm  $\pm 3\%$ ; 51 TO 100 mm  $\pm 2\%$ ;  
 101 TO 300 mm  $\pm 1\%$ ; ABOVE 300 mm  $\pm 0.5\%$ ;
5. SHORT TIME CURRENT RATING 40 KA rms. FOR 3 Sec.
6. APPLICABLE STANDARD : IS:9921 PART I TO V ; IEC : 62271 - 102
7. ROTATING STOOL BASE HAVING 2 Nos. SEALED BALL BEARINGS OF ADEQUATE SIZE
8. SUPPORT STRUCTURE & INSULATORS INCLUDING FIXING HARDWARE NOT IN OUR SCOPE OF SUPPLY

Drawing approval subject to valid vendor registration

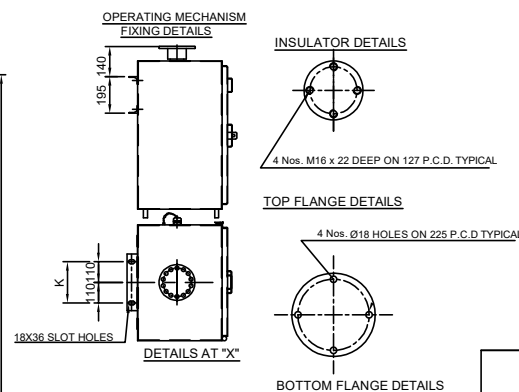
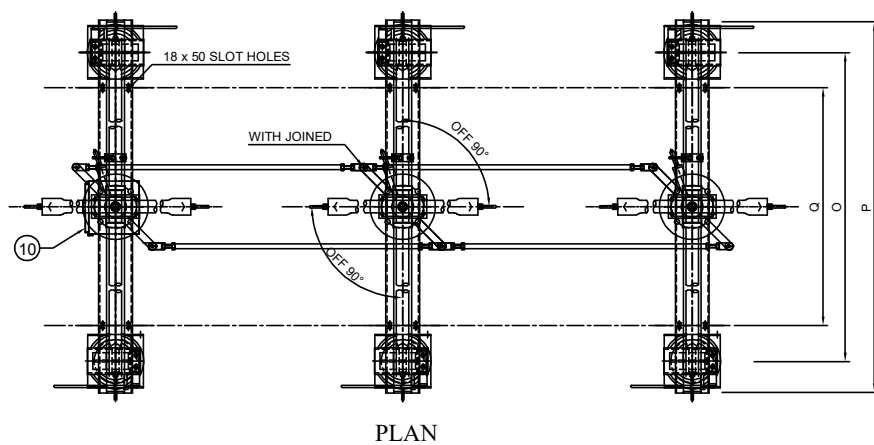

ELECTRICAL PARAMETERS

1. NOMINAL SYSTEM VOLTAGE : 220 kV
2. HIGHEST SYSTEM VOLTAGE : 245 kV
3. P.F. WITHSTAND VOLTAGE : 460 kV rms
4. IMPULSE WITHSTAND VOLTAGE : 1050 kV PEAK

BASE FIXING DETAILS

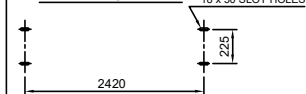

WEIGHT:

NET WEIGHT OF THE ISOLATOR MATERIALS  
EXCLUDING INSULATOR : 800 Kg. (Approx.)

Chief Engineer/Projects  
APTRANSCO/VS/Vijayawada.

REVISIONS			
D	C	B	A

TITLE:

G.A. OF 220 kV, 2000 AMPS,  
TP, HDB, RT, ISOLATOR WITH OUT E.S.



GR POWER SWITCHGEAR LTD.,  
JEEDIMETLA HYDERABAD-500 055 INDIA

SCALE: N.T.S

DATE: 31-08-2023

DRAWN: [Signature]

CHECKED: [Signature]

APPROVED: [Signature]

DRG.NO:

3. GR APT 01

REV

DIMENSIOSNS

A	B	C	D	E	F	G	H	I	J	K	L	M	N	O	P	Q	R	S	T	U	V	W	X
175	2300	75	150	205	1395	140	1200	NA	195	220	NA	4500	225	3200	3600	2420	NA	5500	2800	NA	NA	NA	NA

NOTE: 1. DRAWING APPROVAL SUBJECT TO VALID TYPE TEST

REPORTS, TO BE CHECKED DURING ACCEPTANCE TESTS

2. FOR EPC CONTRACTS ONLY

FIXED CONTACT ASSEMBLY:

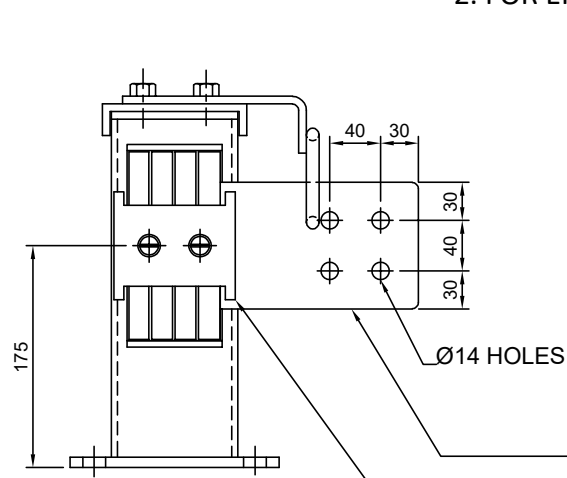

ELEVATION

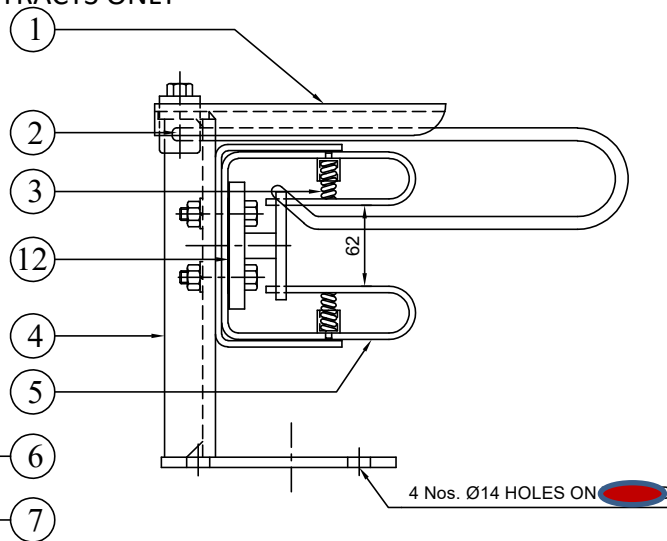

END VIEW

MOVING CONTACT ASSEMBLY

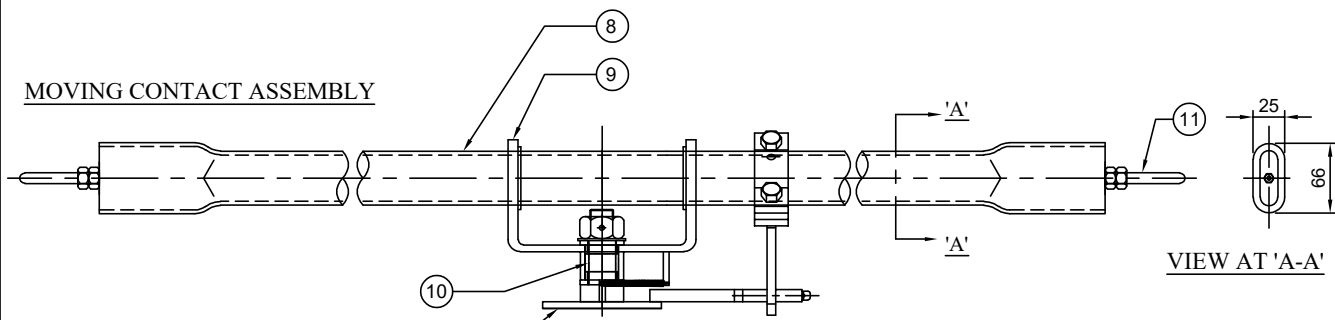

VIEW AT 'A-A'

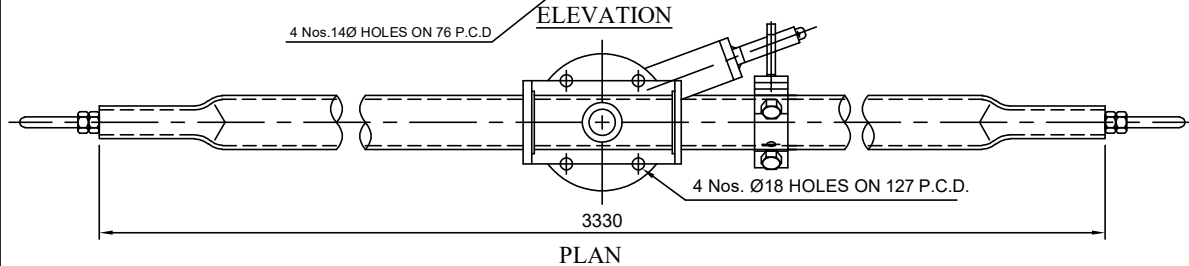

PLAN

PART LIST:

- |   |        |
|---|--------|
| 1. HOOD (18 SWG M.S. HDG)                               | 06 Nos |
| 2. ARCING HORNS (Ø10 ROD M.S. HDG)                      | 06 Nos |
| 3. SPRINGS (Ø2 mm STAINLESS STEEL.)                     | 48 Nos |
| 4. SUPPORTING CHANNEL (135 x 40 mm M.S. HDG)            | 06 Nos |
| 5. JAWS (32 x 5 HDEC STRIP 4 Nos. SILVER PLATED)        | 24 Nos |
| 6. JUMPER PLATE (100 x 20 ALU. FLAT)                    | 06 Nos |
| 7. SPACER (ALUMINUM)                                    | 06 Nos |
| 8. MOVING CONTACT ARM (50 OD x 34 ID CU. TUBE )         | 03 Nos |
| 9. MC SUPPORT WITH NYLON BUSH                           | 06 Nos |
| 10. CENTER MECHANISM (M.S. HDG, TURN & TWIST MECHANISM) | 03 Nos |
| 11. ARCING HORN FOR MOVING CONTACT (Ø10 ROD M.S. HDG)   | 06 Nos |
| 12. BI-METALLIC SHEET (2 mm THICK Alu. + Cu.)           | 06 Nos |

NOTE:

- ALL DIMENSIONS ARE IN MILLIMETER
- ALL FERROUS PARTS ARE HOT DIP GALVANIZED
- ALL NON-FERROUS CONTACT POINTS ARE SILVER PLATED  
MICRONS REMAINING CONTACT AREA TIN PLATED.
- THE MOVING CONTACT ASSEMBLY SHOWN FOR TURN & TWIST ASSEMBLY  
Thickness of Silver plating : 15 Microns Minimum

**Chief Engineer/Projects  
APTRANSCO/VS/Vijayawada.**

Drawing approval subject to valid vendor registration

REVISIONS

D C B A

TITLE:

**MAIN SWITCH CONTACT ASSEMBLY**  
(FOR 220 kV 2000 Amps)

SCALE:N.T.S

DATE

21-03-2023

DRAWN

CHECKED

APPROVED

DRG.NO:

4. GRM APT 02

REV



**GR POWER SWITCHGEAR LTD.,**  
JEEDIMETLA HYDERABAD-500 055 INDIA

317  
BOQ  
721

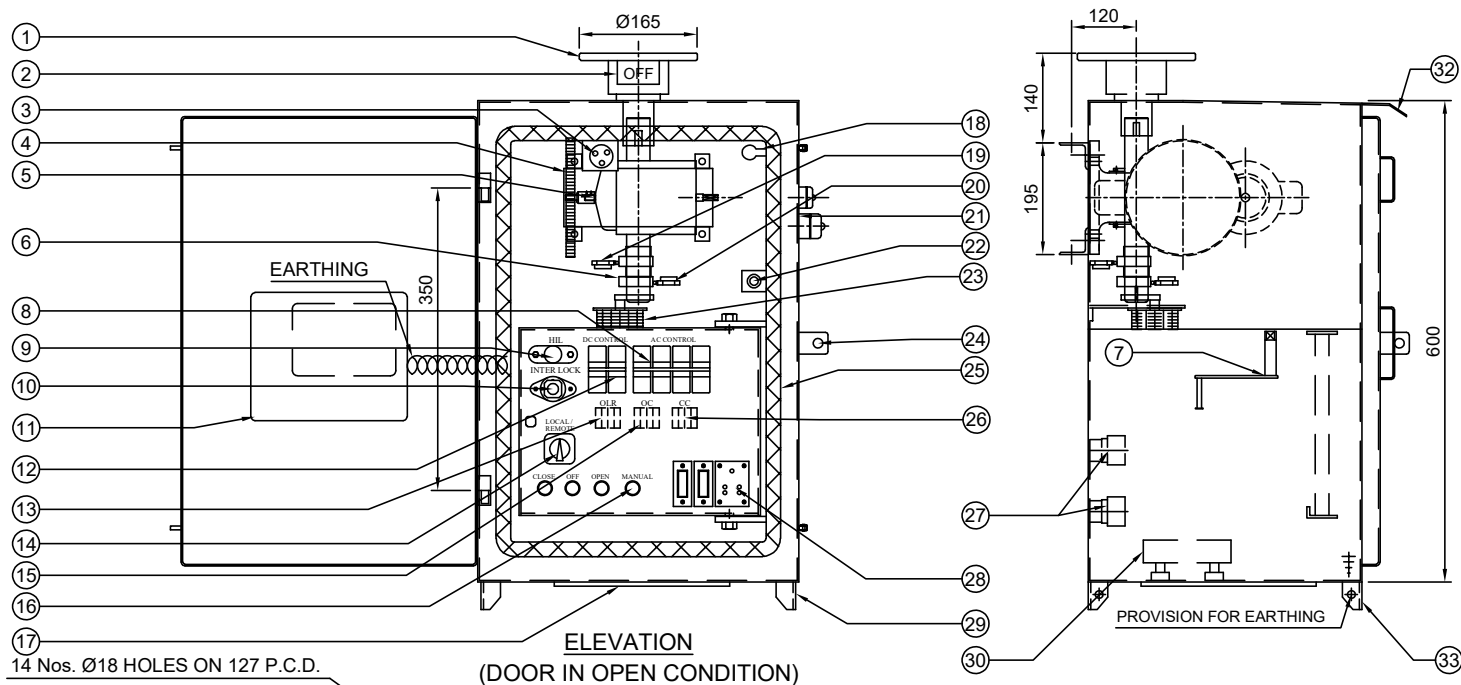

- PART LIST:**
- OUTPUT FLANGE (8 mm THICK, 14 HOLES)
  - ON/OFF INDICATOR
  - THERMOSTAT (30 TO 85°C RECOMMENDED SETTING 40°)
  - GEAR BOX (SPUR / WORM & WORM SHAFT, RATIO 1 : 630)  
(MATERIAL : EN8 / FORGED STEEL)
  - MOTOR (Ø3, 415 Volts, 0.5 HP MOTOR)
  - LIMIT SWITCH OPERATING CAM
  - OPERATING HANDLE FIXED TO DOOR
  - AC CONTROL SWITCH (4 POLE MCB) S1
  - PUSH CAP (FOR HIL)
  - HANDLE INTERLOCK (HIL)
  - SCHEMATIC DIAGRAM PLATE
  - DC CONTROL SWITCH (2 POLE MCB) S2
  - OVER LOAD RELAY CUM SINGLE PHASE PREVENTOR (OLR)
  - LOCAL/REMOTE SWITCH (S3)
  - OPENING CONTACTOR (OC)
  - OPEN / CLOSE / MANUAL / OFF PUSH BUTTON (PBO / PBC / PBH / EPB)
  - DETACHABLE CABLE GLANDS FIXING PLATE (WITH OUT GLANDS)
  - CUBICLE LAMP HOLDER
  - LIMIT SWITCH (LSO)
  - LIMIT SWITCH (LSC)
  - CUBICLE WITH DOOR (3 mm THICK ALU SHEET)
  - DOOR OPERATED LIGHT SWITCH (LS)
  - AUX. SWITCH (12 NO + 12 NC)
  - PROVISION FOR PAD LOCK
  - RUBBER GASKET (EPDM)
  - CLOSING CONTACTOR (CC)
  - TERMINAL BLOCK (UBT - 4 TYPE OF ELMEX OR ITS EQUIVALENT)
  - HEATER / POWER SOCKET SWITCHES (HS,PSS)
  - BOX SUPPORT
  - HEATER, 80 WATTS, 240 V
  - MANUAL OPERATING CAP / COVER
  - RAIN SHADE
  - PROVISION FOR EARTHING TERMINALS

14 Nos. Ø18 HOLES ON 127 P.C.D.

**ELEVATION**  
(DOOR IN OPEN CONDITION)

**LEFT SIDE VIEW**  
(DOOR IN CLOSE CONDITION)

**FIXING DETAILS FOR SUPPORTING STRUCTURE**

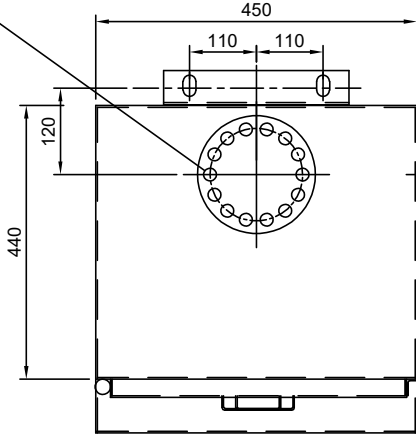
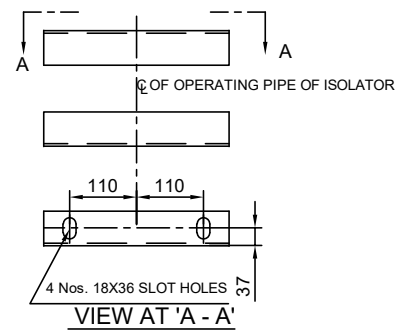

**PLAN**

**GASKET DETAILS**

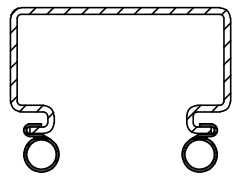

Drawing approval subject to valid vendor registration

**NOTE :**

- ALL DIMENSIONS ARE IN MILLIMETERS
- CUBICLE WILL BE NATURAL ALUMINIUM FINISH FOR INSIDE AND OUTSIDE.
- DEGREE OF PROTECTION IP:55 AS PER IS/IEC 60529
- 20% SPARE TERMINALS WILL BE PROVIDED
- WIRING WILL BE DONE WITH 1100 V. GRADE
  - FOR POWER CIRCUIT (AC SUPPLY) : 2.5 Sq.MM Cu. STRANDED
  - FOR AUXILIARY CIRCUIT (DC SUPPLY) : 2.5 Sq.MM Cu. STRANDED P.V.C. INSULATED CONDUCTOR
- WEIGHT OF THE BOX : 80 Kg (Approx.)
- LUBRICATION OF GEARS : NON HARDENED GREASE FILLED GEAR BOX

**AUX. SWITCH CONTACT DETAILS FOR ISOLATOR**  
(12 NO / 12 NC)

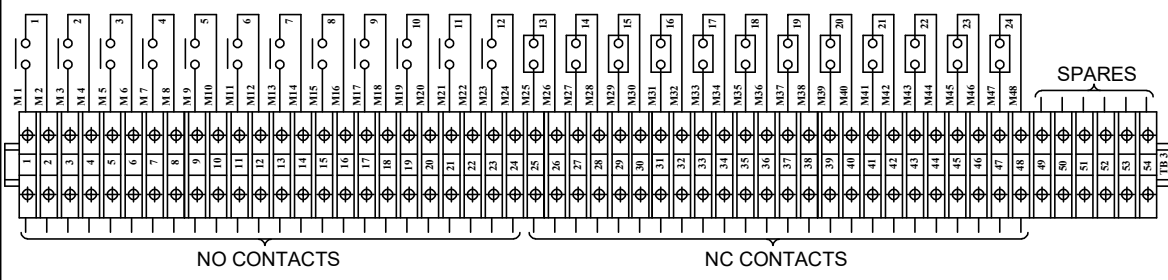

**Chief Engineer/Projects**  
**APTRANSCO/VIS/Vijayawada.**

REVISIONS			
D	C	B	A

**TITLE:**  
**GENERAL ARRANGEMENT OF MOTOR OPERATING MECHANISM FOR 220 KV M/S.**

SCALE:N.T.S		
DATE		21-01-2023
DRAWN		
CHECKED		
APPROVED		
DRG.NO:	4. GM APT 03	
REV		

**GR POWER SWITCHGEAR LTD.,**  
**JEEDIMETLA HYDERABAD-500 055 INDIA**

NOTE: 1. DRAWING APPROVAL SUBJECT TO VALID TYPE TEST REPORTS, TO BE CHECKED DURING ACCEPTANCE TESTS  
2. FOR EPC CONTRACTS ONLY

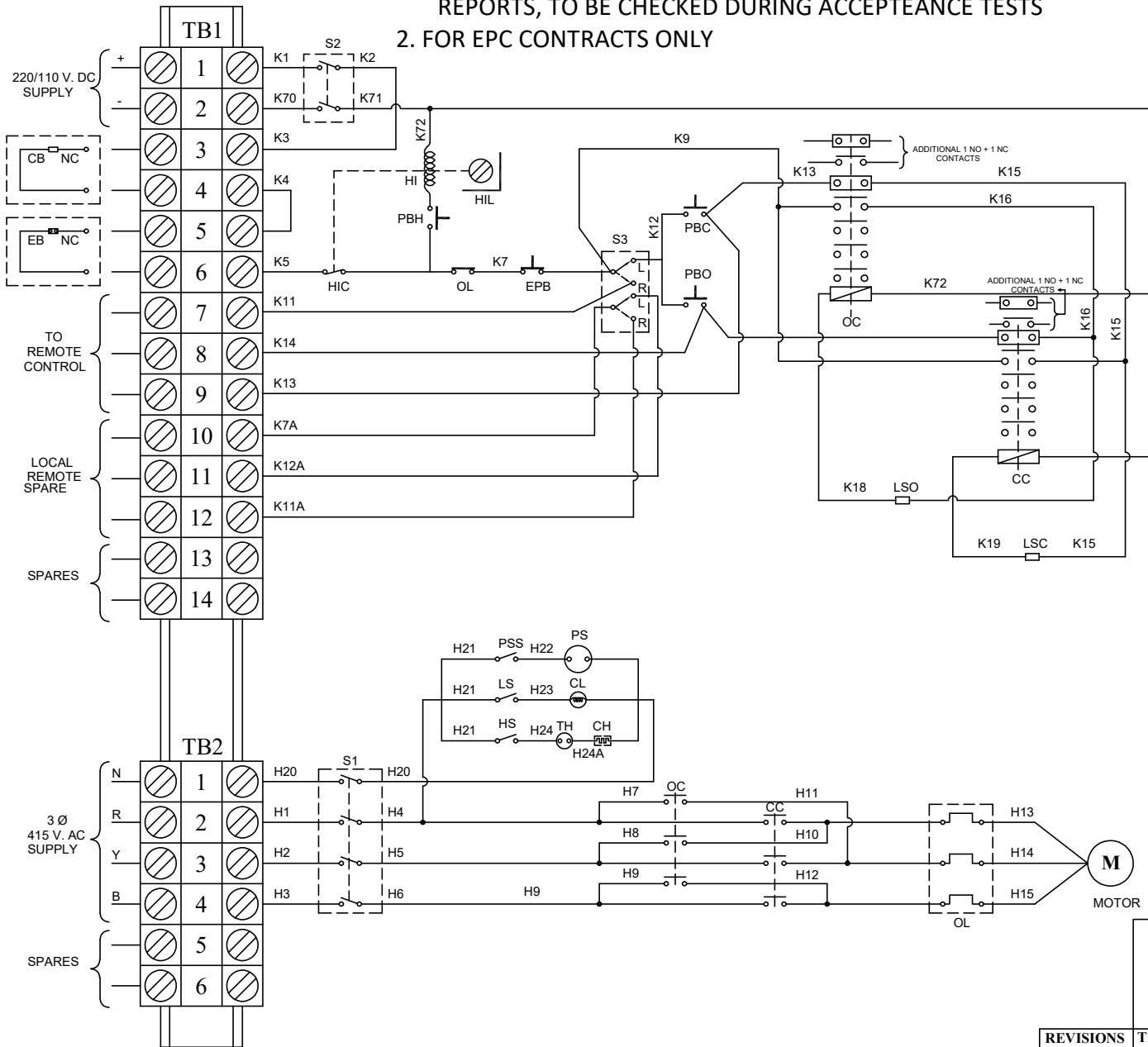

LEGEND	DESCRIPTION	MAKE	319
HIC	HANDLE INTERLOCK CONTACT	SWITRON/RECOM	721
M	MOTOR 3Ø 415 V. 0.5 HP	REMI/ELECEN/HEMAL/HINDUSTAN	
CH	CUBICLE HEATER 80 WATTS	KONTAKT/RAMANA ELECT.	
S1	A.C. SUPPLY CONTROL SWITCH, 16 A MCB	SCHNEIDER/C&S/SIEMENS/CHINT	
S2	D.C. SUPPLY CONTROL SWITCH, 10 A MCB	SCHNEIDER/C&S/SIEMENS/CHINT	
S3	LOCAL/REMOTE SELECTOR SWITCH 16 A	SWITRON/RECOM	
OC,CC	OPEN/CLOSE CONTACTORS, 9 A	SCHNEIDER/C&S/SIEMENS/CHINT	
OL	OVER LOAD RELAY WITH SPP 1.0 TO 1.6 A	SCHNEIDER/C&S/SIEMENS/CHINT	
PBO,PBC	OPEN/CLOSE PUSH BUTTONS, 4 A	C&S/JAIBALAJI/VAISHNO/SIEMENS/TECHNI	
LSO,LSC	OPEN/CLOSE LIMIT SWITCHES, 10 A	JAI BALAJI/MANI	
PBH	MANUAL HANDLE PUSH BUTTONS, 4 A	C&S/JAIBALAJI/VAISHNO/SIEMENS/TECHNI	
EPB	EMERGENCY PUSH BUTTON, 4 A	C&S/JAIBALAJI/VAISHNO/SIEMENS/TECHNI	
HI	HANDLE INTERLOCK COIL, 20 WATTS	SELMECH/GRPS	
HIL	MANUAL HANDLE KEY INTERLOCK	PSI/EE	
LS,PSS,HS	LIGHT, SOCKET, HEATER SWITCHES, 5A	MARU OR ITS EQUIVALENT	
CL	CUBICLE LAMP HOLDER	MARU OR ITS EQUIVALENT	
PS	POWER SOCKET, 5A	MARU OR ITS EQUIVALENT	
TB	TERMINAL BLOCKS (UBT-4)	ELMEX / CONNECTWELL / VIN MECH	
TH	THERMOSTAT	BEPL	

**OPERATING INSTRUCTIONS:**

- DON'T OPERATE THE ISOLATOR WHEN THE 'CIRCUIT BREAKER' IS IN 'ON'
- ISOLATOR OPERATION IS POSSIBLE ONLY WHEN THE INTERLOCK CONDITIONS ARE SATISFIED.
- FOR MANUAL OPERATION FOLLOW THE FOLLOWING INSTRUCTIONS:-
  - BY PRESSING THE PUSH BUTTON (PBH) REMOVE THE CASTLE KEY AND KEEP THE KEY IN HANDLE LOCK AND ROTATE FOR GETTING WAY TO INSERT THE OPERATING HANDLE.
  - INSERT THE OPERATING HANDLE AND ROTATE IN CLOCK / ANTI CLOCK WISE DIRECTIONS FOR TO OPEN / CLOSE THE ISOLATOR.
  - IF MANUAL OPERATION IS NOT NEEDED RESTORE THE CASTLE KEY IN THE HANDLE INTERLOCK AND ROTATE.

Drawing approval subject to valid vendor registration

**Chief Engineer/Projects  
APTRANSCO/VS/Vijayawada.**

REVISIONS	TITLE:	SCALE:N.T.S
D C B A	<b>SCHMATIC DIAGRAM FOR MOTOR CONTROL PANEL FOR 220 KV</b>	DATE: 21-01-2023
		DRAWN: [Signature]
		CHECKED: [Signature]
		APPROVED: [Signature]
	<b>GR POWER SWITCHGEAR LTD., JEEDIMETLA HYDERABAD-500 055 INDIA</b>	DRG.NO: 4. GM APT 04
		REV: [ ]

NOTE: 1. DRAWING APPROVAL SUBJECT TO VALID TYPE TEST REPORTS, TO BE CHECKED DURING ACCEPTANCE TESTS  
2. FOR EPC CONTRACTS ONLY

NAME PLATE DETAILS FOR ISOLATOR

 MANUFACTURED & SUPPLIED BY <b>GR POWER SWITCHGEAR LTD.,</b> JEEDIMETLA, HYDERABAD - 500 055	
CUSTOMER :	M/s. TRANSMISSION CORPORATION OF AP LIMITED
PROJECT :	-----
CONTRACTOR :	-----
P.O. NO :	----- Dt. : -----
TYPE :	HDB SL. NO : AS APPLICABLE YEAR OF Mfg. : 2023
RATING :	Un 220 KV ; In : 2000 A ; WEIGHT IN KG : -----
IMPLUSE(UI) :	1050 KV Peak; SWITCHING(Us): -----KV Peak;
P.F. :	.460 KV rms; STC(lth): 40 KA rms; DURATION: 3 Sec;
OPERATING MECHANISM :	MOTOR, 3 Ph., 415 V, 0.5 HP
CONTROL VOLTAGE :	220/110 V DC CREEPAGE: -----

Control voltage 220V DC

Project, contractor, PO, date ,year of MFG shall be stamped during inspection

- Minimum 300mm plinth shall be maintained for CT/PT/CVT/ Isolators/IVT in the substation during foundation works to ensure Safe live to ground clearance as per IE rules.
- since the supply of terminal connectors is not in the scope of Manufacturer as mentioned in the drawings. The EPC contractor Shall be instructed to supply the same in line with CT/PT/CVT/Isolator /IVTs requirement and compatibility.

**Chief Engineer/Projects**  
**APTRANSCO/Vs/Vijayawada.**

**NOTES :**

- ENGRAVED LETTER SIZE : 3 mm
- LETTER ETCHED WHITE ON BLACK BACKGROUND
- MATERIAL : ALUMINUM
- THICKNESS : 1 mm

Drawing approval subject to valid vendor registration

REVISIONS				TITLE:	SCALE:N.T.S	DATE	DRAWN	CHECKED	APPROVED
D	C	B	A						
				<b>NAME PLATE DETAILS</b> <b>(FOR 220 kV ISOLATOR)</b>		21-03-2023			
 <b>GR POWER SWITCHGEAR LTD.,</b> <b>JEEDIMETLA HYDERABAD-500 055 INDIA</b>					DRG.NO:	REV			
					4. GZ APT 05				

**SCHEDULE OF GUARANTEED TECHNICAL PARTICULARS FOR 220KV, 2000A WITHOUT EARTH SWITCH**

S.No	DESCRIPTION		220 KV
1	Type/Installation	:	"DB" Double Break - OUTDOOR
2	Manufacturer's Name and country of manufacture	:	GR POWER SWITCHGEAR LTD., HYDERABAD
3	Standards according to which the isolators are manufactured.	:	IS 9921Part I to V.& IEC 62271-102
4	Maximum design voltage at which the isolator can operate (kV).	:	245 KV
5	Frequency (Hz)	:	50 Hz
6	Rated voltage (kV)	:	220KV
7	Maximum current that can be safely interrupted by the Isolator inductive (A & % PF) Capacitive (A & % PF)	:	0.7 Amps at 0.15 p.f.
8	Continuous current rating normal (Amps) under site conditions (Amps).	:	2000 Amps
9	Rated short time current		<u>MAIN SWITCH</u>
	i) For 3 Seconds (kA rms)	:	40 KA rms
	ii) For 1 Second (kA rms)	:	Not Applicable
	iii) Rated peak short time current (KV P)	:	100 KA rms
10	Current density at the minimum cross section of		
	a) Moving blade (Amps/Sq.mm)	:	2.0 Amps/Sq.mm for HDE Cu. Tube
	b) Terminal pad	:	1.0 Amp/Sq.mm for EC grade Alu. Flat.
	c) Contacts	:	1.6 Amps/Sq.mm for HDE Cu. Flat.
11	Maximum temperature rise of current carrying parts when carrying rated current continuously (Deg.C).	:	Within the specified limits of IS/IEC 62271-102.
12	Insulation levels		
	i) Impulse withstand voltage (kV Peak) Phase to Earth Isolating Distance.	:	1050 KV Peak
	ii) Switching surge withstand voltage (kV Peak) Phase to Earth isolating distance.	:	Not applicable

**Chief Engineer/Projects  
APTRANSCO/VS/Vijavawada.**

S.No	DESCRIPTION		220 KV
	iii) Power Frequency withstand voltage (kV rms) Phase to Earth isolating distance.	:	460 KV rms
13	Minimum clearance in air		
	i) Between poles (mm)	:	4000 mm for a phase spacing of 4500 mm
	ii) Between live parts and earth (mm)	:	2100 mm
	iii) Between live parts when switch is open.		
	a) On the same pole (mm)	:	2800 mm
	b) Between adjacent poles (mm)	:	3000 mm
14	Rated mechanical terminal load		
	i) Load along the terminal connector side (Kg).	:	102 Kgs
	ii) Load across the terminal connector side (Kg).	:	33.7 Kgs
15	Torque required to operate the switch in Kg.m.	:	40 Kg m
16	Contact Zone		
	i) Horizontal deflection (mm)	}	Not applicable
	ii) Vertical deflection (mm)		
	iii) Total amplitude of longitudinal movement w.r.t conductor supporting fixed contact		
17	Design and construction		
	i) No. of insulators per pole	:	Three
	ii) No. of breaks per pole	:	Two
	iii) Type of closing / opening mechanism (Horizontal / vertical break straight etc.).	:	Horizontal break for Isolator
	iv. Contacts		
	a) Material and grade	:	Hard Drawn Electrolytic Copper flat, silver plated micron thickness.
	b) Cross-sectional area (Sq.mm)	:	Thickness of Silver plating : 15 Microns Minimum 1280 Sq.mm for 2000A

Drawing approval subject to valid vendor registration

**Chief Engineer/Projects**  
**APTRANSCO/VS/Vijayawada.**

S.No	DESCRIPTION	220 KV
v	Moving blades	
	a) Material and grade	: Thickness of Silver plating : 15 Microns Minimum Hard Drawn Electrolytic Copper tube, silver plated of 0.05 micron thickness.
	b) Cross-sectional area (Sq.mm)	: 829 Sq.mm for 1600A
vi)	Contact support	
	a) Material and size of channel / block.	: 8 mm Thick MS HDG
vii)	Rain hood-material grade and size	: MS HDG
viii)	Turn and twist mechanism	
	a) Material and size of clamps	: 40 x 10 MS HDG Flat
	b) Material size of springs	: 14 swg SS wire
	c) Whether springs are encased	: Not encased
ix)	Nuts and bolts	Drawing approval subject to valid vendor registration
	a) Size, material and grade in live parts.	: Lessthan M8 are of stainless steel
	b) Size, material and grade in other parts.	: M8 and above are of MS HDG.
x)	Insulator base plate material and size of plate below insulators.	: 12 mm thick M.S. Hot dip galvanised plate
xi)	Bearings	
	a) Material and size of housing	: MS HDG suitable for 50 ID Ball Bearing
	b) No. of bearings, location & size	: 2 Nos. below centre rotating post insulator
xii)	Tandem pipe	
	a) Size, length class and No. of pipes	: As per GA drawings
	b) Size of shackle screw	: Suitable for 40 NB
	c) No. of bearings / bush and its material and size.	: 6 Nos. bush bearings, brass, 16 mm ID Size.
xiii)	Type of interlock	: Electrical interlock between Isolator and circuit breaker.
xiv)	Down pipe size, length and class	: 50 mm NB Class B GI Pipe.

**Chief Engineer/Projects**  
**APTRANSCO/Vs/Vijayawada.**

S.No	DESCRIPTION	220 KV
xv)	Type of universal/swivel joint	
	a) Between bearing & down pipe	: Universal joint
	b) Between down pipe and operating mechanism.	: Vernier Flange
xvi)	Operating mechanism	Motor operated mechanism for M.S
	a) Control cabinet	
	Material and thickness	: 3 mm Thick ALU Sheet
	Degree of protection	: IP : 55 as per IS 2147
	Type size and no. of cable glands.	: Compression type, 2 Nos. 19 mm. (Contractor scope of supply)
	Whether removable gland plate provided.	: Yes, removable gland plate provided.
	b) Make type, rating and Qty. of Motors	: Ø3, 415v, 0.5 HP Motor
	Auxiliary blocks	: 12 NO / 12 NC contacts for Main Switch Mani 10 A, 2 A DC breaking with 2A - 1 No.
	Terminal blocks	: UBT-4
	Insulated Wires	: 1100 V grades, 2.5 Sq.mm PVC For Auxiliary Circuit and 2.5 Sq.mm for Power circuit
	HRC Fuse	: Not Applicable, MCB's
	Space Heater	: 1 No. 230V AC. 80 Watts / Ramana Electrical
	Interlocks	: 1 Set PSI / 20 Watts magnetic - 1 No.
xvii)	Base	
	a) Size of steel sections used	: 150 X 75 mm
	b) Overall size	: 3600 x 150 x 75 mm x 5 mm
	c) Total weight	: 52 Kgs approx

for GR POWER SWITCHGEAR LTD.,

Drawing approval subject to valid vendor registration



AUTHORIZED SIGNATORY

**Chief Engineer/Projects**  
**APTRANSCO/VS/Vijayawada.**