

7215512/2023/EEMRT-ENE51



**GR POWER SWITCHGEAR LIMITED**  
 PLOT NO:27/B IDA JEEDIMETLA  
 HYDERABAD

**LIST OF 220 KV STD ISOLATOR DRAWINGS/DOCUMENTS**

CUSTOMER :	SLNO.	DRG.NO.	REV	DESCRIPTION OF DRAWINGS/DOCUMENTS
M/s TRANSMISSION CORPORATION OF ANDHRA PRADESH LIMITED	1	3. GR APT 01	0	220 KV , 800 AMPS,TP,DB,RT,ISOLATOR WITH OUT E. S
	2	4. GRM APT 02	0	MAIN SWITCH CONTACT ASSEMBLY (800 A)
	3	4. GM APT 03	0	MOTOR OPERATING MECHANISM FOR 220 KV ISOLATOR
	4	4. GM APT 04	0	SECHMATIC DIAGRAM DETAILS FOR 220 KV M/S.
	5	4. GZ APT 05	0	NAME PLATE DETAILS FOR 220 KV
Drawing approval subject to valid vendor registration				
<b>Chief Engineer/Projects</b> <b>APTRANSCO/VS/Vijayawada.</b>				

PREPARED BY	CHECKED BY	APPROVED BY

NOTE: 1. DRAWING APPROVAL SUBJECT TO VALID TYPE TEST REPORTS, TO BE CHECKED DURING ACCEPTANCE TESTS  
 2. FOR EPC CONTRACTS ONLY

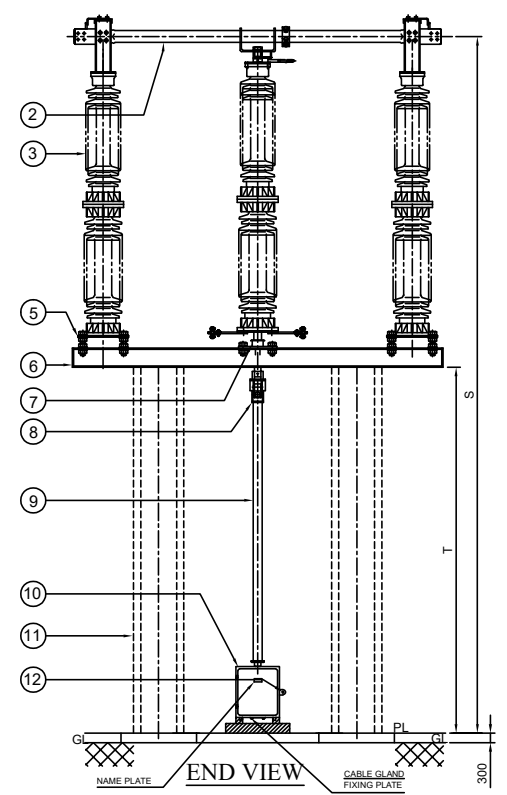
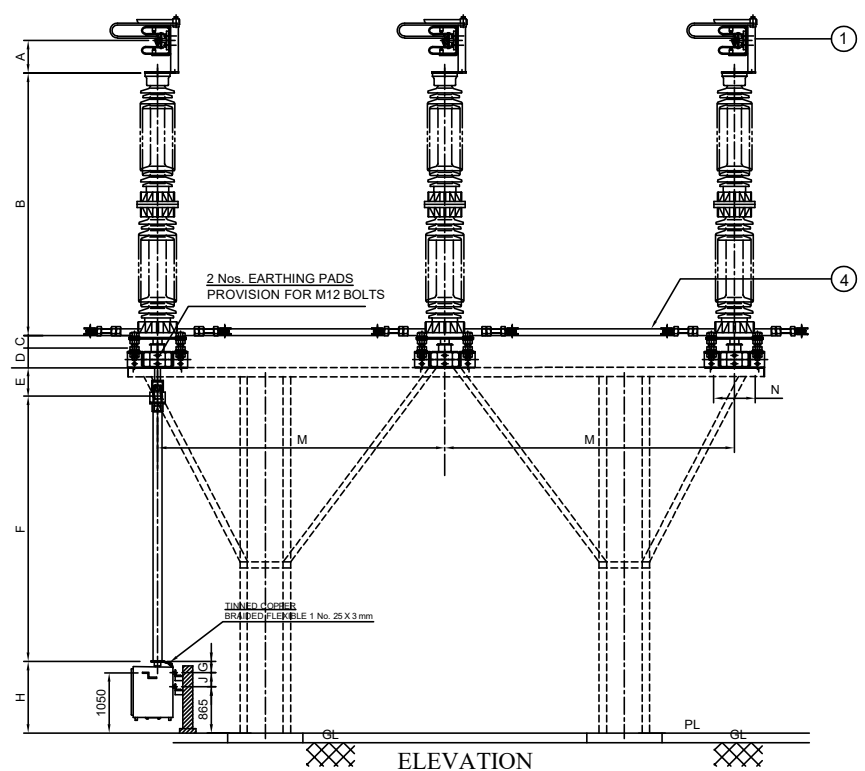

**PART LIST:**

1. FIXED CONTACT ASSEMBLY
2. MOVING CONTACT ASSEMBLY
3. INSULATOR STACK (NOT IN OUR SCOPE OF SUPPLY)
4. TANDEM PIPE (32 NB, G.I. PIPE)
5. ELEVATOR PLATE (12 mm THICK )
6. BASE CHANNEL (150 x 75 x 5 mm THICK MS CHANNEL)
7. ROTATING SHAFT WITH LEVER ARM & CLAMP (M.S. HOT DIP GALVANIZED)
8. UNIVERSAL JOINT ARRANGEMENT
9. DOWN OPERATING PIPE (50 NB, G.I. PIPE)
10. OPERATING MECHANISM FOR M.S. (MOTOR)
11. SUPPORTING STRUCTURE (NOT IN OUR SCOPE OF SUPPLY)
12. PROVISION FOR PADLOCK

- 6 Nos.
- 3 Nos.
- 9 Nos.
- 2 Nos.
- 6 Nos.
- 3 Nos.
- 3 Nos.
- 1 No.
- 1 No.
- 1 No.
- 1 Set.
- 1 No.

**REFERENCE DRAWINGS:**

- FOR ISOLATOR CONTACT DETAILS (800A) ----- 4. GRM APT 02
- FOR OPERATING MECHANISM DETAILS (M.S.)----- 4. GM APT 03
- FOR SCHEMATIC DIAGRAM DETAILS (M.S.)----- 4. GM APT 04
- FOR NAME PLATED DETAILS----- 4. GZ APT 05

Thickness of Silver plating : 15 Microns Minimum

**NOTES:**

1. ALL DIMENSIONS ARE IN MILLIMETERS
2. ALL FERROUS PARTS ARE HOT DIP GALVANIZED (87 MICRONS)
3. ALL NON-FERROUS CONTACT POINTS ARE SILVER PLATED (15 MICRONS)
4. THE INDICATED DIMENSIONS ARE SUBJECT TO THE MANUFACTURING TOLERANCE:  
 UP TO 50 mm ---±3%; 51 TO 100 mm ---±2%;  
 101 TO 300 mm ---±1%; ABOVE 300 mm ---±0.5%;
5. SHORT TIME CURRENT RATING 40 KA rms. FOR 3 Sec.
6. APPLICABLE STANDARD : IS:9921 PART I TO V ; IEC : 62271 - 102
7. ROTATING STOOL BASE HAVING 2 Nos. SEALED BALL BEARINGS OF ADEQUATE SIZE
8. SUPPORT STRUCTURE & INSULATORS INCLUDING FIXING HARDWARE NOT IN OUR SCOPE OF SUPPLY

**NOTE: 1. DRAWING APPROVAL SUBJECT TO VALID TYPE TEST REPORTS, TO BE CHECKED DURING ACCEPTANCE TESTS**  
**2. FOR EPC CONTRACTS ONLY**

**ELECTRICAL PARAMETERS**

- 1. NOMINAL SYSTEM VOLTAGE : 220 kV
- 2. HIGHEST SYSTEM VOLTAGE : 245 kV
- 3. P.F. WITHSTAND VOLTAGE : 460 kV rms
- 4. IMPULSE WITHSTAND VOLTAGE : 1050 kV PEAK

**BASE FIXING DETAILS** 18 x 50 SLOT HOLES

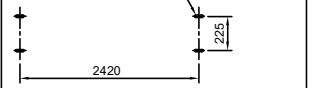

**WEIGHT:**

NET WEIGHT OF THE ISOLATOR METALLICS EXCLUDING INSULATOR : 800 Kg. (Approx.)

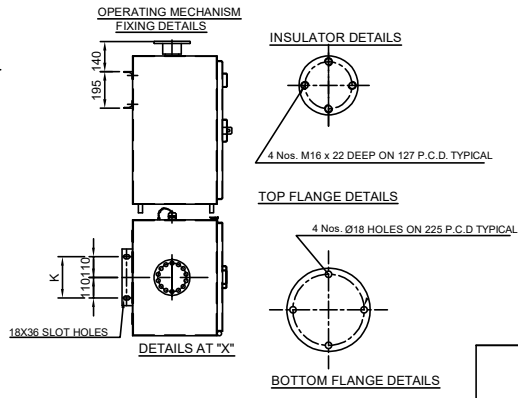
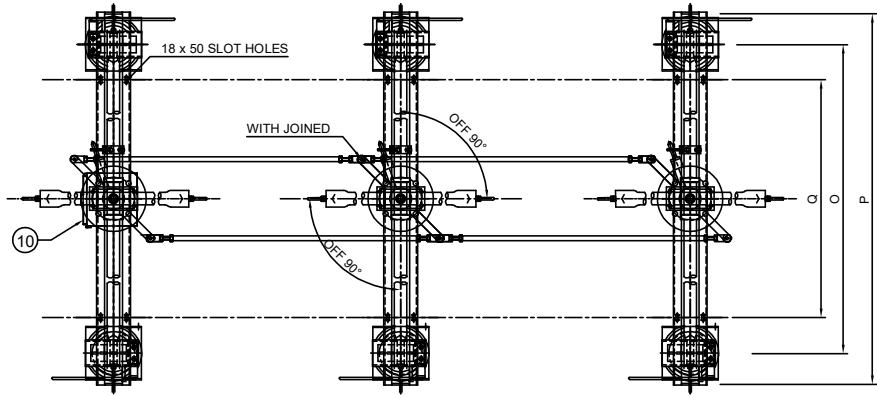

**PLAN**

Drawing approval subject to valid vendor registration

**Chief Engineer/Projects**  
**APTRANSCO/VS/Vijayawada.**

DIMENSIOSNS																							
A	B	C	D	E	F	G	H	I	J	K	L	M	N	O	P	Q	R	S	T	U	V	W	X
175	2300	75	150	205	1395	140	1200	NA	195	220	NA	4500	225	3200	3600	2420	NA	5500	2800	NA	NA	NA	NA

REVISIONS				
D	C	B	A	

**TITLE:**  
 G.A. OF 220 kV, 800 AMPS,  
 TP, HDB, RT, ISOLATOR WITH OUT E.S.

**SCALE:** N.T.S

**DATE:** 21-03-2023

**DRAWN:** [Signature]

**CHECKED:** [Signature]

**APPROVED:** [Signature]

**DRG.NO:** 3. GR APT 01

**REV**

**GR POWER SWITCHGEAR LTD.,**  
**JEEDIMETLA HYDERABAD-500 055 INDIA**

FIXED CONTACT ASSEMBLY:

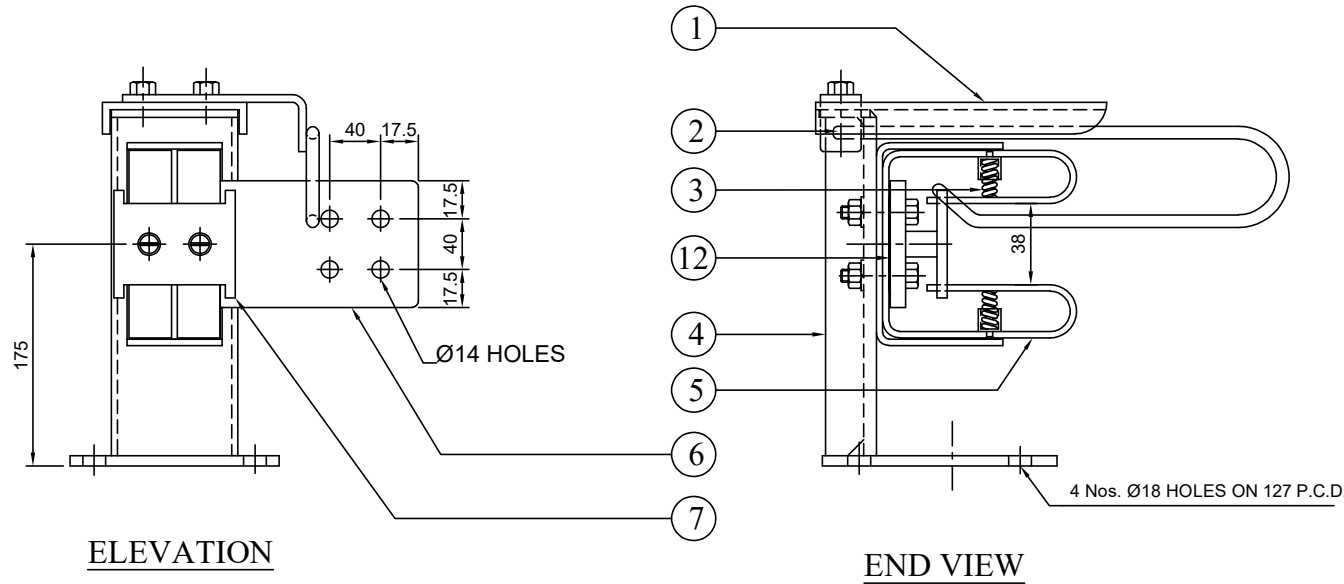

ELEVATION

END VIEW

MOVING CONTACT ASSEMBLY

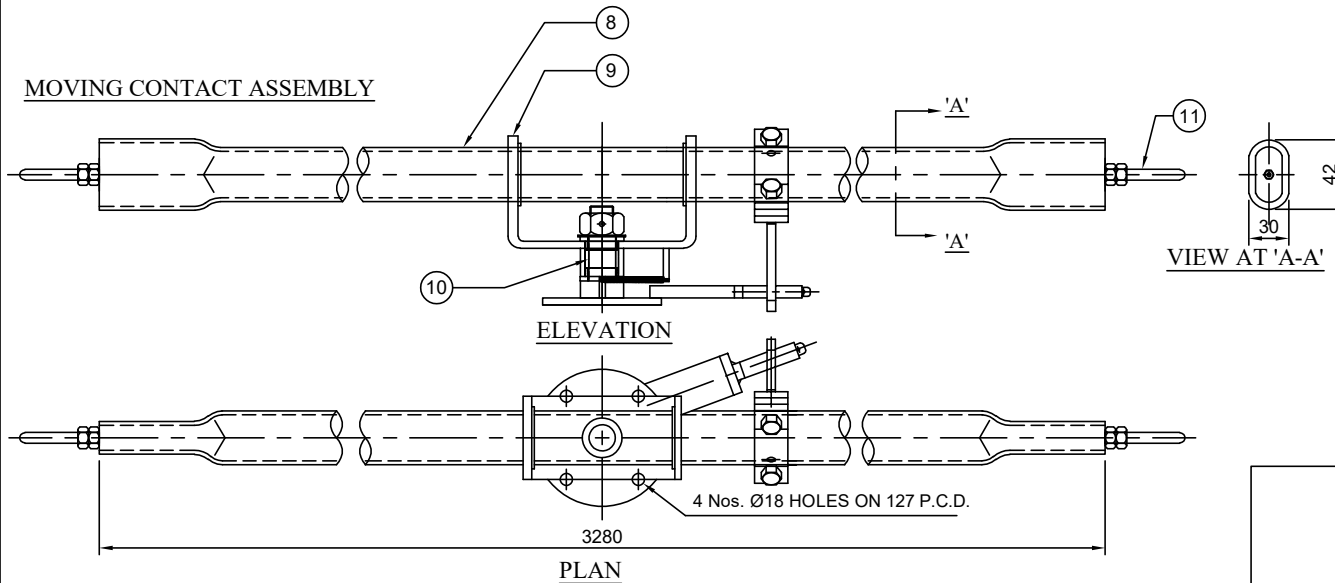

ELEVATION

PLAN

NOTE: 1. DRAWING APPROVAL SUBJECT TO VALID TYPE TEST REPORTS, TO BE CHECKED DURING ACCEPTANCE TESTS  
2. FOR EPC CONTRACTS ONLY

Drawing approval subject to valid vendor registration

PART LIST:

1. HOOD (18 SWG M.S. HDG)
2. ARCING HORNS (Ø10 ROD M.S. HDG)
3. SPRINGS (Ø2 mm STAINLESS STEEL.)
4. SUPPORTING CHANNEL (100 x 40 mm M.S. HDG)
5. JAWS (32 x 4 HDEC STRIP 2 Nos. SILVER PLATED)
6. JUMPER PLATE (75 x 12 ALU. FLAT)
7. SPACER (ALUMINUM)
8. MOVING CONTACT ARM (38 OD x 30 ID CU. TUBE )
9. MC SUPPORT WITH NYLON BUSH
10. CENTER MECHANISM (M.S. HDG, TURN & TWIST MECHANISM)
11. ARCING HORN FOR MOVING CONTACT(Ø10 ROD M.S. HDG)
12. BI-METALLIC SHEET (2 mm THICK Alu. + Cu.)

209  
BOQ  
721

- 06 Nos
- 06 Nos
- 24 Nos
- 06 Nos
- 12 Nos
- 06 Nos
- 06 Nos
- 03 Nos
- 06 Nos
- 03 Nos
- 06 Nos
- 06 Nos

NOTE:

1. ALL DIMENSIONS ARE IN MILLIMETER
2. ALL FERROUS PARTS ARE HOT DIP GALVANIZED
3. ALL NON-FERROUS CONTACT POINTS ARE SILVER PLATED  
MICRONS REMAINING CONTACT AREA TIN PLATED.
4. THE MOVING CONTACT ASSEMBLY SHOWN FOR TURN & TWIST ASSEMBLY  
Thickness of Silver plating : 15 Microns Minimum

**Chief Engineer/Projects  
APTRANSCO/VS/Vijayawada.**

REVISIONS			
D	C	B	A

TITLE: **MAIN SWITCH CONTACT ASSEMBLY**  
(FOR 220 kV 800 Amps)

SCALE:N.T.S	
DATE	21-08-2023
DRAWN	
CHECKED	
APPROVED	



**GR POWER SWITCHGEAR LTD.,**  
JEEDIMETLA HYDERABAD-500 055 INDIA

DRG.NO:	REV
4. GRM APT 02	

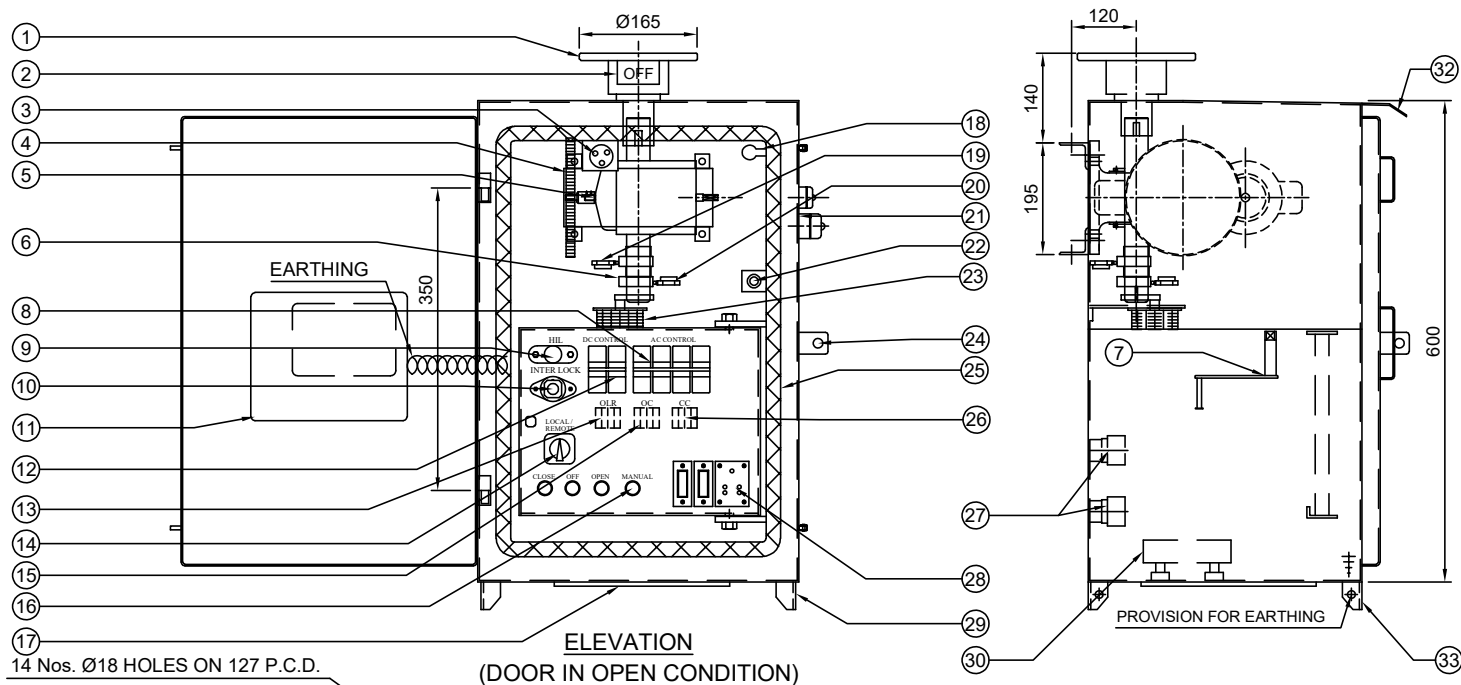

- PART LIST:**
- OUTPUT FLANGE (8 mm THICK, 14 HOLES)
  - ON/OFF INDICATOR
  - THERMOSTAT (30 TO 85°C RECOMMENDED SETTING 40°)
  - GEAR BOX (SPUR / WORM & WORM SHAFT, RATIO 1 : 630)  
(MATERIAL : EN8 / FORGED STEEL)
  - MOTOR (Ø3, 415 Volts, 0.5 HP MOTOR)
  - LIMIT SWITCH OPERATING CAM
  - OPERATING HANDLE FIXED TO DOOR
  - AC CONTROL SWITCH (4 POLE MCB) S1
  - PUSH CAP (FOR HIL)
  - HANDLE INTERLOCK (HIL)
  - SCHEMATIC DIAGRAM PLATE
  - DC CONTROL SWITCH (2 POLE MCB) S2
  - OVER LOAD RELAY CUM SINGLE PHASE PREVENTOR (OLR)
  - LOCAL/REMOTE SWITCH (S3)
  - OPENING CONTACTOR (OC)
  - OPEN / CLOSE / MANUAL / OFF PUSH BUTTON (PBO / PBC / PBH / EPB)
  - DETACHABLE CABLE GLANDS FIXING PLATE (WITH OUT GLANDS)
  - CUBICLE LAMP HOLDER
  - LIMIT SWITCH (LSO)
  - LIMIT SWITCH (LSC)
  - CUBICLE WITH DOOR (3 mm THICK ALU SHEET)
  - DOOR OPERATED LIGHT SWITCH (LS)
  - AUX. SWITCH (12 NO + 12 NC)
  - PROVISION FOR PAD LOCK
  - RUBBER GASKET (EPDM)
  - CLOSING CONTACTOR (CC)
  - TERMINAL BLOCK (UBT - 4 TYPE OF ELMEX OR ITS EQUIVALENT)
  - HEATER / POWER SOCKET SWITCHES (HS,PSS)
  - BOX SUPPORT
  - HEATER, 80 WATTS, 240 V
  - MANUAL OPERATING CAP / COVER
  - RAIN SHADE
  - PROVISION FOR EARTHING TERMINALS

14 Nos. Ø18 HOLES ON 127 P.C.D.

**ELEVATION**  
(DOOR IN OPEN CONDITION)

**LEFT SIDE VIEW**  
(DOOR IN CLOSE CONDITION)

**FIXING DETAILS FOR SUPPORTING STRUCTURE**

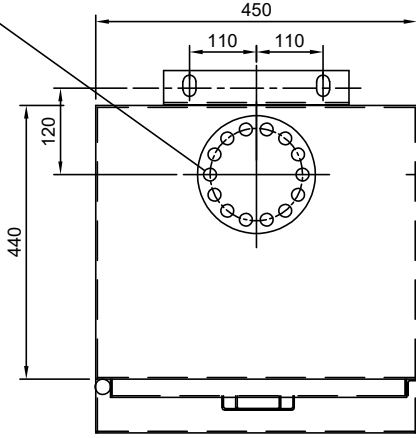
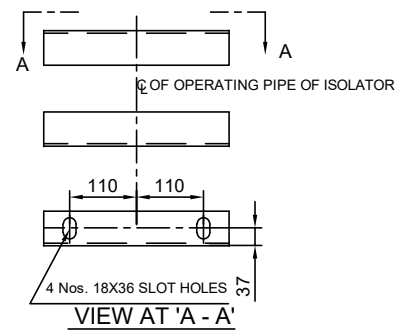

**PLAN**

**AUX. SWITCH CONTACT DETAILS FOR ISOLATOR**  
(12 NO / 12 NC)

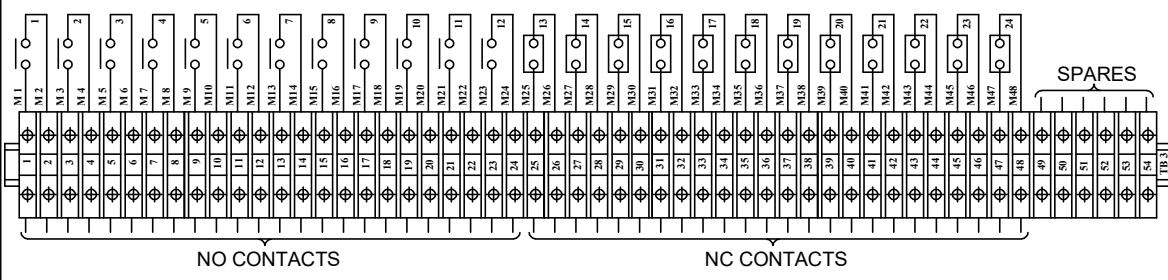

**GASKET DETAILS**

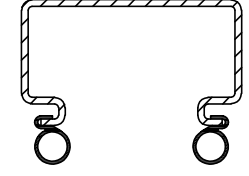

Drawing approval subject to valid vendor registration

**NOTE :**

- ALL DIMENSIONS ARE IN MILLIMETERS
- CUBICLE WILL BE NATURAL ALUMINIUM FINISH FOR INSIDE AND OUTSIDE.
- DEGREE OF PROTECTION IP:55 AS PER IS/IEC 60529
- 20% SPARE TERMINALS WILL BE PROVIDED
- WIRING WILL BE DONE WITH 1100 V. GRADE
  - FOR POWER CIRCUIT (AC SUPPLY) : 2.5 Sq.MM Cu. STRANDED
  - FOR AUXILIARY CIRCUIT (DC SUPPLY) : 2.5 Sq.MM Cu. STRANDED P.V.C. INSULATED CONDUCTOR
- WEIGHT OF THE BOX : 80 Kg (Approx.)
- LUBRICATION OF GEARS : NON HARDENED GREASE FILLED GEAR BOX

**Chief Engineer/Projects**  
**APTRANSCO/VS/Vijayawada.**

REVISIONS			
D	C	B	A

**TITLE:**  
**GENERAL ARRANGEMENT OF MOTOR OPERATING MECHANISM FOR 220 KV M/S.**



**GR POWER SWITCHGEAR LTD.,**  
**JEEDIMETLA HYDERABAD-500 055 INDIA**

SCALE:N.T.S	
DATE	21-03-2023
DRAWN	
CHECKED	
APPROVED	
DRG.NO:	4. GM APT 03
REV	

NOTE: 1. DRAWING APPROVAL SUBJECT TO VALID TYPE TEST REPORTS, TO BE CHECKED DURING ACCEPTANCE TESTS  
2. FOR EPC CONTRACTS ONLY

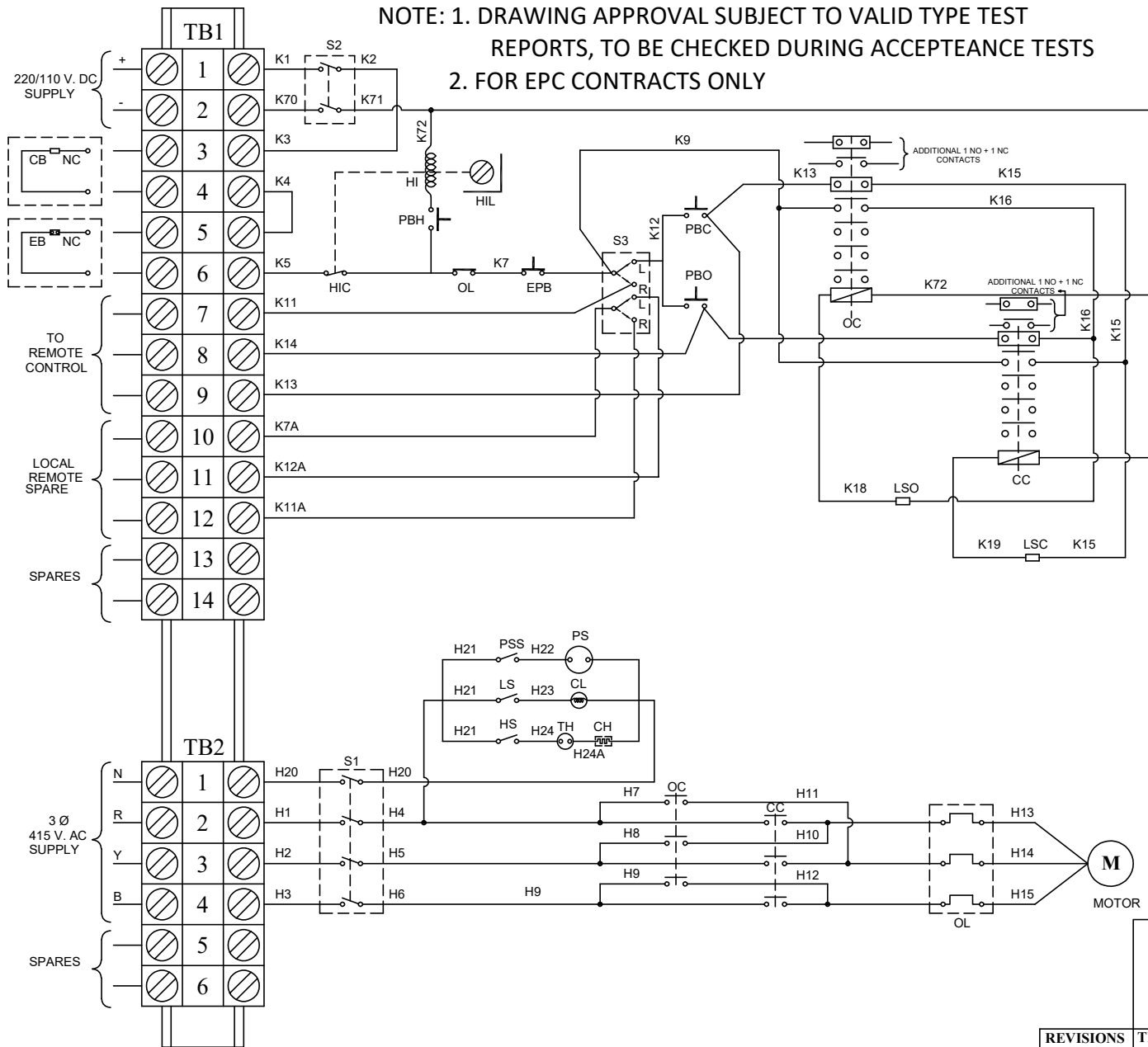

LEGEND	DESCRIPTION	MAKE	211
HIC	HANDLE INTERLOCK CONTACT	SWITRON/RECOM	721
M	MOTOR 3Ø 415 V. 0.5 HP	REMI/ELECEN/HEMAL/HINDUSTAN	
CH	CUBICLE HEATER 80 WATTS	KONTAKT/RAMANA ELECT.	
S1	A.C. SUPPLY CONTROL SWITCH, 16 A MCB	SCHNEIDER/C&S/SIEMENS/CHINT	
S2	D.C. SUPPLY CONTROL SWITCH, 10 A MCB	SCHNEIDER/C&S/SIEMENS/CHINT	
S3	LOCAL/REMOTE SELECTOR SWITCH 16 A	SWITRON/RECOM	
OC,CC	OPEN/CLOSE CONTACTORS, 9 A	SCHNEIDER/C&S/SIEMENS/CHINT	
OL	OVER LOAD RELAY WITH SPP 1.0 TO 1.6 A	SCHNEIDER/C&S/SIEMENS/CHINT	
PBO,PBC	OPEN/CLOSE PUSH BUTTONS, 4 A	C&S/JAIBALAJI/VAISHNO/SIEMENS/TECHNIC	
LSO,LSC	OPEN/CLOSE LIMIT SWITCHES, 10 A	JAI BALAJI/MANI	
PBH	MANUAL HANDLE PUSH BUTTONS, 4 A	C&S/JAIBALAJI/VAISHNO/SIEMENS/TECHNIC	
EPB	EMERGENCY PUSH BUTTON, 4 A	C&S/JAIBALAJI/VAISHNO/SIEMENS/TECHNIC	
HI	HANDLE INTERLOCK COIL, 20 WATTS	SELMECH/GRPS	
HIL	MANUAL HANDLE KEY INTERLOCK	PSI/EE	
LS,PSS,HS	LIGHT, SOCKET, HEATER SWITCHES, 5A	MARU OR ITS EQUIVALENT	
CL	CUBICLE LAMP HOLDER	MARU OR ITS EQUIVALENT	
PS	POWER SOCKET, 5A	MARU OR ITS EQUIVALENT	
TB	TERMINAL BLOCKS (UBT-4)	ELMEX / CONNECTWELL / VIN MECH	
TH	THERMOSTAT	BEPL	

**OPERATING INSTRUCTIONS:**

- DON'T OPERATE THE ISOLATOR WHEN THE 'CIRCUIT BREAKER' IS IN 'ON'
- ISOLATOR OPERATION IS POSSIBLE ONLY WHEN THE INTERLOCK CONDITIONS ARE SATISFIED.
- FOR MANUAL OPERATION FOLLOW THE FOLLOWING INSTRUCTIONS:-
  - BY PRESSING THE PUSH BUTTON (PBH) REMOVE THE CASTLE KEY AND KEEP THE KEY IN HANDLE LOCK AND ROTATE FOR GETTING WAY TO INSERT THE OPERATING HANDLE.
  - INSERT THE OPERATING HANDLE AND ROTATE IN CLOCK / ANTI CLOCK WISE DIRECTIONS FOR TO OPEN / CLOSE THE ISOLATOR.
  - IF MANUAL OPERATION IS NOT NEEDED RESTORE THE CASTLE KEY IN THE HANDLE INTERLOCK AND ROTATE.

Drawing approval subject to valid vendor registration

**Chief Engineer/Projects  
APTRANSCO/VS/Vijayawada.**

REVISIONS	D	C	B	A

TITLE:	<b>SCHMATIC DIAGRAM FOR MOTOR CONTROL PANEL FOR 220 KV</b>	
SCALE:N.T.S		
DATE	21-05-2023	
DRAWN		
CHECKED		
APPROVED		
DRG.NO:	4. GM APT 04	REV
<b>GR POWER SWITCHGEAR LTD., JEEDIMETLA HYDERABAD-500 055 INDIA</b>		

NOTE: 1. DRAWING APPROVAL SUBJECT TO VALID TYPE TEST REPORTS, TO BE CHECKED DURING ACCEPTANCE TESTS  
2. FOR EPC CONTRACTS ONLY

NAME PLATE DETAILS FOR ISOLATOR

	MANUFACTURED & SUPPLIED BY	
	<b>GR POWER SWITCHGEAR LTD., JEEDIMETLA, HYDERABAD - 500 055</b>	
CUSTOMER :	M/s. TRANSMISSION CORPORATION OF AP LIMITED	
PROJECT :	-----	
CONTRACTOR :	-----	
P.O. NO :	-----	Dt. : -----
TYPE :	HDB	SL. NO : AS APPLICABLE YEAR OF Mfg. : 2023
RATING :	Un 220 KV ; In : 800 A ;	WEIGHT IN KG : -----
IMPLUSE(UI) :	1050 KV Peak ; SWITCHING(Us) : -----	KV Peak ;
P.F. :	460 KV rms ; STC(lth) : 40 KA rms ;	DURATION : 3 Sec ;
OPERATING MECHANISM :	MOTOR, 3 Ph., 415 V, 0.5 HP	
CONTROL VOLTAGE :	220/110 V DC	CREEPAGE : -----

Control voltage 220V DC

Drawing approval subject to valid vendor registration



**Chief Engineer/Projects  
APTRANSCO/VS/Vijayawada.**

1. Minimum 300mm plinth shall be maintained for CT/PT/CVT/ Isolators/IVT in the substation during foundation works to ensure Safe live to ground clearance as per IE rules.
2. since the supply of terminal connectors is not in the scope of Manufacturer as mentioned in the drawings. The EPC contractor Shall be instructed to supply the same in line with CT/PT/CVT/Isolator /IVTs requirement and compatibility.

Project, contractor, PO, date ,year of MFG shall be stamped during inspection

**NOTES :**

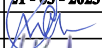
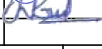
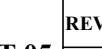
1. ENGRAVED LETTER SIZE : 3 mm
2. LETTER ETCHED WHITE ON BLACK BACKGROUND
3. MATERIAL : ALUMINUM
4. THICKNESS : 1 mm

<table border="1"> <tr> <th colspan="4">REVISIONS</th> </tr> <tr> <th>D</th> <th>C</th> <th>B</th> <th>A</th> </tr> <tr> <td> </td> <td> </td> <td> </td> <td> </td> </tr> <tr> <td> </td> <td> </td> <td> </td> <td> </td> </tr> </table>	REVISIONS				D	C	B	A									<b>TITLE:</b>  <b>NAME PLATE DETAILS (FOR 220 kV ISOLATOR)</b>	SCALE:N.T.S	
	REVISIONS																		
	D	C	B	A															
DATE	21-03-2023																		
DRAWN																			
CHECKED																			
APPROVED																			
DRG.NO:	4. GZ APT 05	REV																	
 <b>GR POWER SWITCHGEAR LTD., JEEDIMETLA HYDERABAD-500 055 INDIA</b>																			

**SCHEDULE OF GUARANTEED TECHNICAL PARTICULARS FOR 220KV, 800A WITHOUT EARTH SWITCH**

S.No	DESCRIPTION		220 KV
1	Type/Installation	:	"DB" Double Break - OUTDOOR
2	Manufacturer's Name and country of manufacture	:	GR POWER SWITCHGEAR LTD., HYDERABAD
3	Standards according to which the isolators are manufactured.	:	IS 9921Part I to V & IEC 62271-102
4	Maximum design voltage at which the isolator can operate (kV).	:	245 KV
5	Frequency (Hz)	:	50 Hz
6	Rated voltage (kV)	:	220KV
7	Maximum current that can be safely interrupted by the Isolator inductive (A & % PF) Capacitive (A & % PF)	:	0.7 Amps at 0.15 p.f.
8	Continuous current rating normal (Amps) under site conditions (Amps).	:	800 Amps
9	Rated short time current		<u>MAIN SWITCH</u>
	i) For 3 Seconds (kA rms)	:	40 KA rms
	ii) For 1 Second (kA rms)	:	Not Applicable
	iii) Rated peak short time current (KV P)	:	100 KA rms
10	Current density at the minimum cross section of		
	a) Moving blade (Amps/Sq.mm)	:	2.0 Amps/Sq.mm for HDE Cu. Tube
	b) Terminal pad	:	1.0 Amp/Sq.mm for EC grade Alu. Flat.
	c) Contacts	:	1.6 Amps/Sq.mm for HDE Cu. Flat.
11	Maximum temperature rise of current carrying parts when carrying rated current continuously (Deg.C).	:	Within the specified limits of IS/IEC 62271-102.
12	Insulation levels		
	i) Impulse withstand voltage (kV Peak) Phase to Earth Isolating Distance.	:	1050 KV Peak
	ii) Switching surge withstand voltage (kV Peak) Phase to Earth isolating distance.	:	Not applicable

Chief Engineer/Projects

APTRANSCO/YS/Vijayawada

S.No	DESCRIPTION		220 KV	
	iii) Power Frequency withstand voltage (kV rms) Phase to Earth isolating distance.	:	460 KV rms	
13	Minimum clearance in air			
	i) Between poles (mm)	:	4000 mm for a phase spacing of 4500 mm	
	ii) Between live parts and earth (mm)	:	2100 mm	
	iii) Between live parts when switch is open.	:	Drawing approval subject to valid vendor registration	
	a) On the same pole (mm)	:		2800 mm
	b) Between adjacent poles (mm)	:		3000 mm
14	Rated mechanical terminal load			
	i) Load along the terminal connector side (Kg).	:	102 Kgs	
	ii) Load across the terminal connector side (Kg).	:	33.7 Kgs	
15	Torque required to operate the switch in Kg.m.	:	40 Kg m	
16	Contact Zone		} Not applicable	
	i) Horizontal deflection (mm)	:		
	ii) Vertical deflection (mm)	:		
	iii) Total amplitude of longitudinal movement w.r.t conductor supporting fixed contact	:		
17	Design and construction			
	i) No. of insulators per pole	:	Three	
	ii) No. of breaks per pole	:	Two	
	iii) Type of closing / opening mechanism (Horizontal / vertical break straight etc.).	:	Horizontal break for Isolator	
	iv. Contacts		Thickness of Silver plating : 15 Microns Minimum Hard Drawn Electrolytic Copper flat, silver plated	
	a) Material and grade	:		 micron thickness.
	b) Cross-sectional area (Sq.mm)	:	512 Sq.mm for 800A	

**Chief Engineer/Projects**  
**APTRANSCO/VS/Vijayawada.**

S.No	DESCRIPTION	220 KV
v	Moving blades	
	a) Material and grade	: Thickness of Silver plating : 15 Microns Minimum Hard Drawn Electrolytic Copper tube, silver plated  micron thickness.
	b) Cross-sectional area (Sq.mm)	: 427 Sq.mm for 800A
vi)	Contact support	
	a) Material and size of channel / block.	: 8 mm Thick MS HDG
vii)	Rain hood-material grade and size	: MS HDG
viii)	Turn and twist mechanism	Drawing approval subject to valid vendor registration
	a) Material and size of clamps	: 40 x 10 MS HDG Flat
	b) Material size of springs	: 14 swg SS wire
	c) Whether springs are encased	: Not encased
ix)	Nuts and bolts	
	a) Size, material and grade in live parts.	: Lessthan M8 are of stainless steel
	b) Size, material and grade in other parts.	: M8 and above are of MS HDG.
x)	Insulator base plate material and size of plate below insulators.	: 12 mm thick M.S. Hot dip galvanised plate
xi)	Bearings	
	a) Material and size of housing	: MS HDG suitable for 50 ID Ball Bearing
	b) No. of bearings, location & size	: 2 Nos. below centre rotating post insulator
xii)	Tandem pipe	
	a) Size, length class and No. of pipes	: As per GA drawings
	b) Size of shackle screw	: Suitable for 40 NB
	c) No. of bearings / bush and its material and size.	: 6 Nos. bush bearings, brass, 16 mm ID Size.
xiii)	Type of interlock	: Electrical interlock between Isolator and circuit breaker.
xiv)	Down pipe size, length and class	: 50 mm NB Class B GI Pipe.

S.No	DESCRIPTION	220 KV
xv)	Type of universal/swivel joint	
	a) Between bearing & down pipe	: Universal joint
	b) Between down pipe and operating mechanism.	: Vernier Flange
xvi)	Operating mechanism	Motor operated mechanism for M.S
	a) Control cabinet	
	Material and thickness	: 3 mm Thick ALU Sheet
	Degree of protection	: IP : 55 as per IS 2147
	Type size and no. of cable glands.	: Compression type, 2 Nos. 19 mm. (Contractor scope of supply)
	Whether removable gland plate provided.	: Yes, removable gland plate provided.
	b) Make type, rating and Qty. of Motors	: Ø3, 415v, 0.5 HP Motor
	Auxiliary blocks	: 12 NO / 12 NC contacts for Main Switch Mani 10 A, 2 A DC breaking with 2A - 1 No.
	Terminal blocks	: UBT-4
	Insulated Wires	: 1100 V grades, 2.5 Sq.mm PVC For Auxiliary Circuit and 2.5 Sq.mm for Power circuit
	HRC Fuse	: Not Applicable, MCB's
	Space Heater	: 1 No. 230V AC. 80 Watts / Ramana Electrical
	Interlocks	: 1 Set PSI / 20 Watts magnetic - 1 No.
xvii)	Base	
	a) Size of steel sections used	: 150 X 75 mm
	b) Overall size	: 3600 x 150 x 75 mm x 5 mm
	c) Total weight	: 52 Kgs approx

for GR POWER SWITCHGEAR LTD.,



AUTHORIZED SIGNATORY

**Chief Engineer/Projects**  
**APTRANSCO/VS/Vijayawada.**