

NOTE: 1. DRAWING APPROVAL SUBJECT TO VALID TYPE TEST

3

4

5

6

38
608

REPORTS, TO BE CHECKED DURING ACCEPTANCE TESTS

2. FOR EPC CONTRACTS ONLY

245 kV CAPACITOR VOLTAGE TRANSFORMER TYPE: CPB-H 245

CLIENT:
(AS APPLICABLE)

END CUSTOMER:
APTRANSCO

PROJECT:
(AS APPLICABLE)

W.O. NO.:
(AS APPLICABLE)

P.O. NO.:
(AS APPLICABLE)

QTY.:
(AS APPLICABLE)

1. Minimum 300mm plinth shall be maintained for CT/PT/CVT/Isolators/IV/LA/Breakers in the Substation during foundation works to ensure safe live to ground clearance as per IE rules.
2. Since the supply of terminal connectors is not in the scope of manufacturer as mentioned in the drawings. The EPC contractor shall be instructed to supply the same in line with CT/PT/CVT/Isolator/IVT/LA/Breakers requirement and compatibility.

Drawing approval subject to valid vendor registration

**CHIEF ENGINEER
PLANNING & POWER SYSTEMS
APTRANSCO**

SR. NO.	REFERENCE OF STD DRGS/ DOCUMENTS	REV.	DESCRIPTION
1.	1HYT903320-057	B	GENERAL ARRANGEMENT - 25mm/kV
2.	1HYT903320-058	B	RATING PLATE - 25mm/kV
3.	1HYT903320-059	B	SECONDARY TERMINAL BOX
4.	1HYT903320-060	A	SECTIONAL VIEW
5.	1HYT903320-072	B	INSULATOR DRAWING- 25mm/kV

Prepared: SR	Checked: SNP	Approved: SN
Without Sep. PL.: <input type="checkbox"/>	Same PL. Same No.: <input type="checkbox"/>	Sep. PL. Other No.: <input type="checkbox"/>
Derived by:	Supersedes:	Supersedes by:
A 2022-06-09		
B 2022-06-28		

LIST OF DOCUMENTS FOR CPB-H 245 TYPE CVT

Scale NTS
T.Sh. 1

We reserve all rights in this document and in the information contained there in reproduction, use or disclosure to third parties without express authority is strictly forbidden ©ABB.

Ⓐ New drg. prepared.

Ⓑ Change in sr no. 1,2,3 & 5

This drawing is a COMPUTER ORIGINAL and does not require signature for its authentication



HITACHI ENERGY INDIA LIMITED (FORMERLY KNOWN AS APPSIL)

1HYT903320-056

Sheets 1

1

2

3

4

5

6

NOTE: 1. DRAWING APPROVAL SUBJECT TO VALID TYPE TEST REPORTS, TO BE CHECKED DURING ACCEPTANCE TESTS
2. FOR EPC CONTRACTS ONLY

Drawing approval subject to valid vendor registration

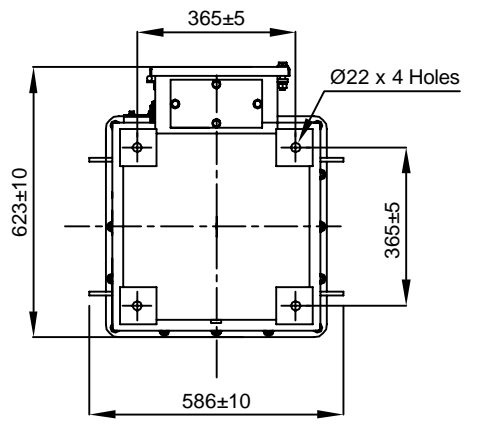

BOTTOM VIEW

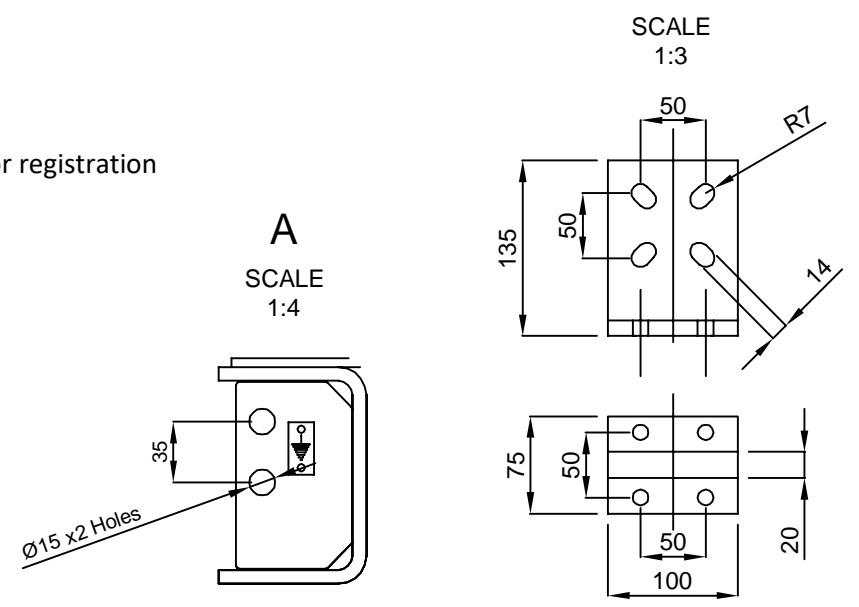

Earthing Terminal Detail

Primary Terminal Detail

**CHIEF ENGINEER
PLANNING & POWER SYSTEMS
APTRANSCO**

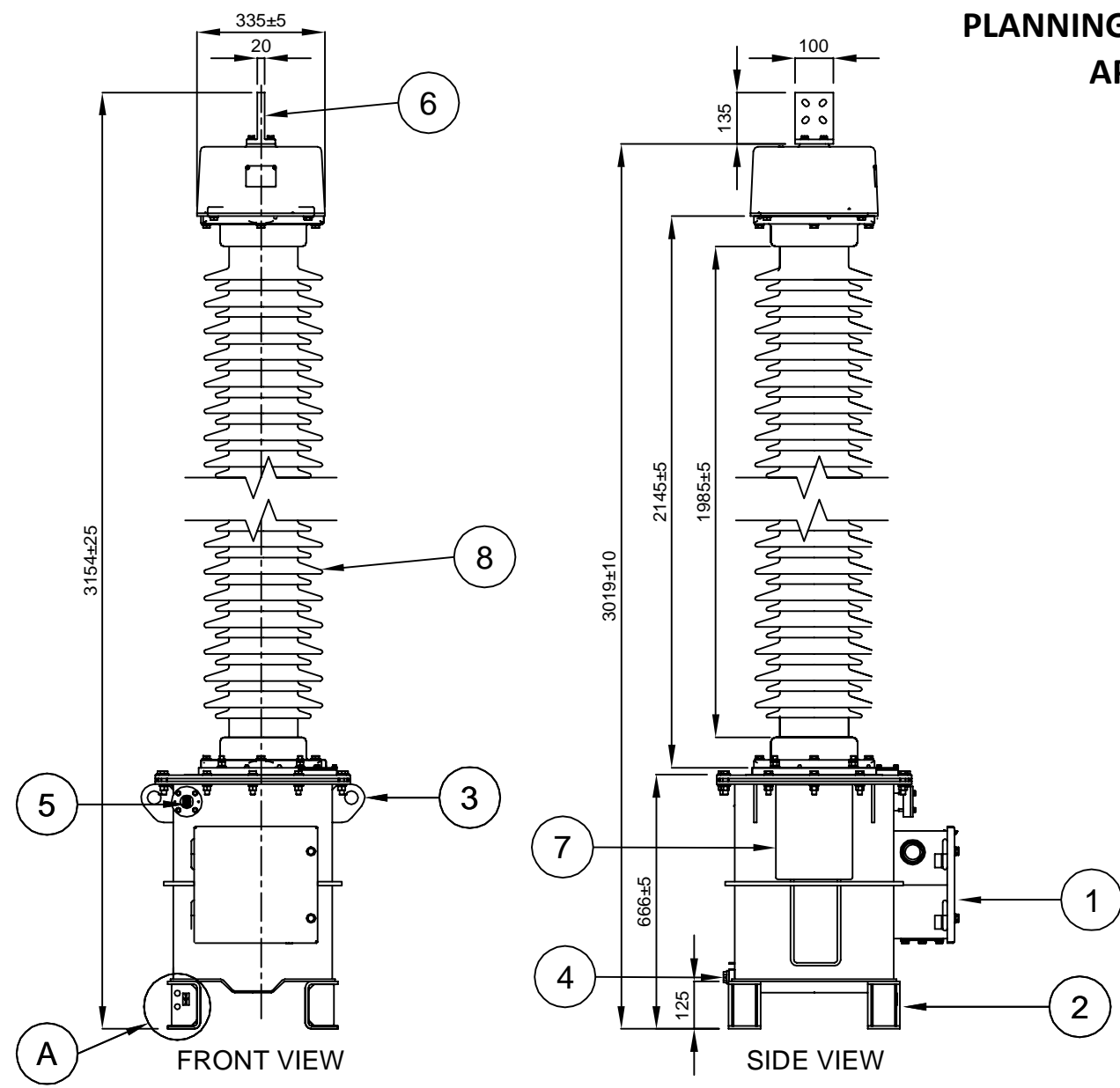

FRONT VIEW

SIDE VIEW

Sr.No.	DESCRIPTION	MATERIAL	QTY.
9	EMU TANK	MS HOT DIP GALVANISED	1
8	INSULATOR	PORCELAIN	1
7	RATING PLATE	ALUMINUM	1
6	PRIMARY TERMINAL	ALUMINUM	1
5	OIL LEVEL INDICATOR	TOUGHENED GLASS	1
4	OIL DRAIN PLUG	MS HOT DIP GALVANISED	1
3	LIFTING LUG	MS HOT DIP GALVANISED	4
2	MOUNTING PAD	MS HOT DIP GALVANISED	4
1	SECONDARY TERMIALANL BOX	MS HOT DIP GALVANISED	1

- Notes:-
- All exposed ferrous parts including tank are hot dip galvanized.
 - Connect the HF Terminal to Earth when carrier coupling device is not used.
 - Nominal Creepage Distance is 6125 mm (25 mm/kV)
 - All Dimensions are in mm. General Tolerance as per ISO:2768-C.
 - Porcelain insulators with maximum one joint.
 - CVD bellow material: Stainless Steel
 - Two nos. earthing provisions provided on mounting pad diagonally.

This drawing is a COMPUTER ORIGINAL for its authentication and does not require signatures

Revision Details:
ⓐ Tank view revised

Revision Details:
ⓐ New drawing prepared.

We reserve all rights in this document and in the information contained there in. Reproduction, use or disclosure to third parties without express authority is strictly forbidden ©ABB.

Revision		
A	2022-06-09	
B	2022-06-29	

245 kV Capacitor Voltage Transformer
Type: CPB-H 245

General Arrangement Drawing

DRAWN: SR	CHECKED: PDS	APPRD.: SN	file: - 3320-057	TOTAL SH. 1
HITACHI ENERGY INDIA LIMITED (FORMERLY KNOWN AS APPSIL)			1HYT903320-057	Sh. NO. 1

We reserve all rights in this document and in the information contained there in. Reproduction, use or disclosure to third parties without express authority is strictly forbidden. © ABB.

Revision Details:
 (A) New drg. prepared.
 (B) Wdg seq revised

This document is COMPUTER ORIGINAL and does not need signature for its authentication

NOTE: 1. DRAWING APPROVAL SUBJECT TO VALID TYPE TEST REPORTS, TO BE CHECKED DURING ACCEPTANCE TESTS
 2. FOR EPC CONTRACTS ONLY

Drawing approval subject to valid vendor registration

200±1

250±1

ABB		HEIL		Made in India	
1Ph. Capacitor voltage transformer	245	Type	CBP-H 245	Serial No.	xxxxxxx
Highest system volt.kV	245	Rated voltage	kV	220/√3	
Rated Insulation level kV	245/460/1050	Total creepage minimum	mm	6125	
Rated frequency Hz	50	Weight of oil	kg	84	
Standard	IEC: 61869-5	Total weight	kg	460	
H.V.(PRI) Cap: C1 pF	4914	Equ.Cap.(Cn)For PLCC pF	4400 ^{+10%} _{-5%}	23/√3	
Int. V(SEC) Cap: C2 pF	42087	Nominal Intermediate volt kV		MM/YYYY	
Temperature category °C	-5 to +50 °C	Date of mfg.		YES	
Total thermal burden VA	750 VA	Suitable for hot line washing		1HYT903320-057	
Class of Insulation	'A'	G.A. drg. No.			

Rated sec. voltage (V)	110/√3	Terminal markings	1a - 1n	Rated burden (VA)	50	Accuracy class	3P
	110/√3		2a - 2n		50		3P
	110/√3		3a - 3n		50		0.2
SIMULTANEOUS LOADING OF SECONDARIES							

EARTH HF TERMINAL WHEN NOT IN USE FOR PLCC

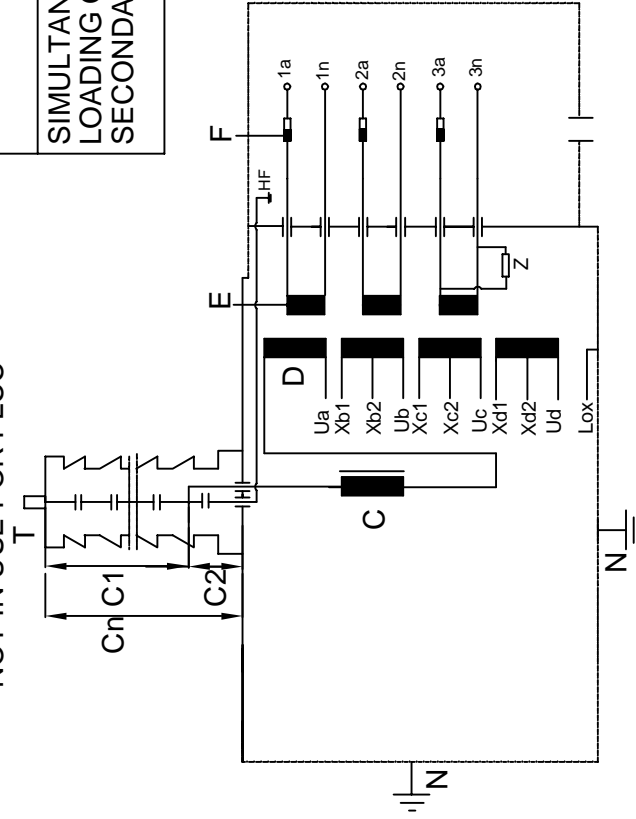

T - H.V. Terminal
 C - Compensating reactor
 D - Primary Winding
 E - Secondary Winding
 F - FUSE
 HF - H.F. Terminal(PLCC)
 N - Earthing
 Z - F.R. Circuit
 Ud-Xd } Compensating windings
 Uc-Xc }
 Ub-Xb }
 Ua-Lead connecting C,D.
 Lox-Earth Terminal

END CUSTOMER: APTRANSCO

HEIL WORKS ORDER NO : (AS APPLICABLE)

CLIENT WORK ORDER NO: (AS APPLICABLE)

ABB is a registered trademark of ABB Asea Brown Boveri Ltd.
 Manufactured by/for a Hitachi Energy company.

- Minimum 300mm plinth shall be maintained for CT/PT/CVT/Isolators/IV/LA/Breakers in the Substation during foundation works to ensure safe live to ground clearance as per IE rules.
- Since the supply of terminal connectors is not in the scope of manufacturer as mentioned in the drawings. The EPC contractor shall be instructed to supply the same in line with CT/PT/CVT/Isolator/IVT/LA/Breakers requirement and compatibility.

**CHIEF ENGINEER
 PLANNING & POWER SYSTEMS
 APTRANSCO**

Revision		
A	2022-06-09	
B	2022-06-28	

**Rating Plate:
 1HYP000428P3**

**Rating & Diagram Plate for
 245kV Capacitor Voltage
 Transformer**

DRAWN: SR

CHECKED: SNP

APPRD.: SN

file :3320-058

TOTAL SH.

1

ABB HITACHI ENERGY INDIA LIMITED
 (FORMERLY KNOWN AS APPSIL)

1HYT903320-058

Sh. NO.

1

1	Rating and Diagram Plate	1	ALUMINUM	Sh. 2mm thk.
QTY	DESCRIPTION	P	MATERIAL /CODE NO	WT LOWER DRG NO.

NOTE: 1. DRAWING APPROVAL SUBJECT TO VALID TYPE TEST REPORTS, TO BE CHECKED DURING ACCEPTANCE TESTS
2. FOR EPC CONTRACTS ONLY

Drawing approval subject to valid vendor registration

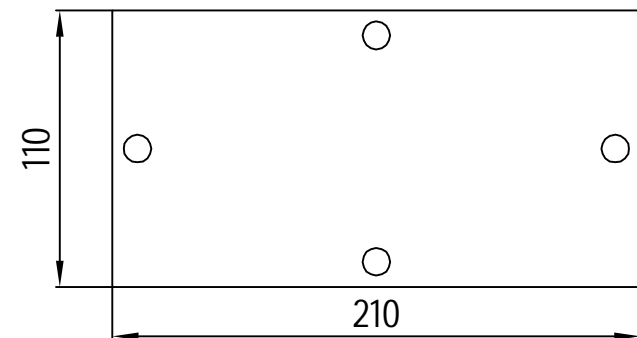
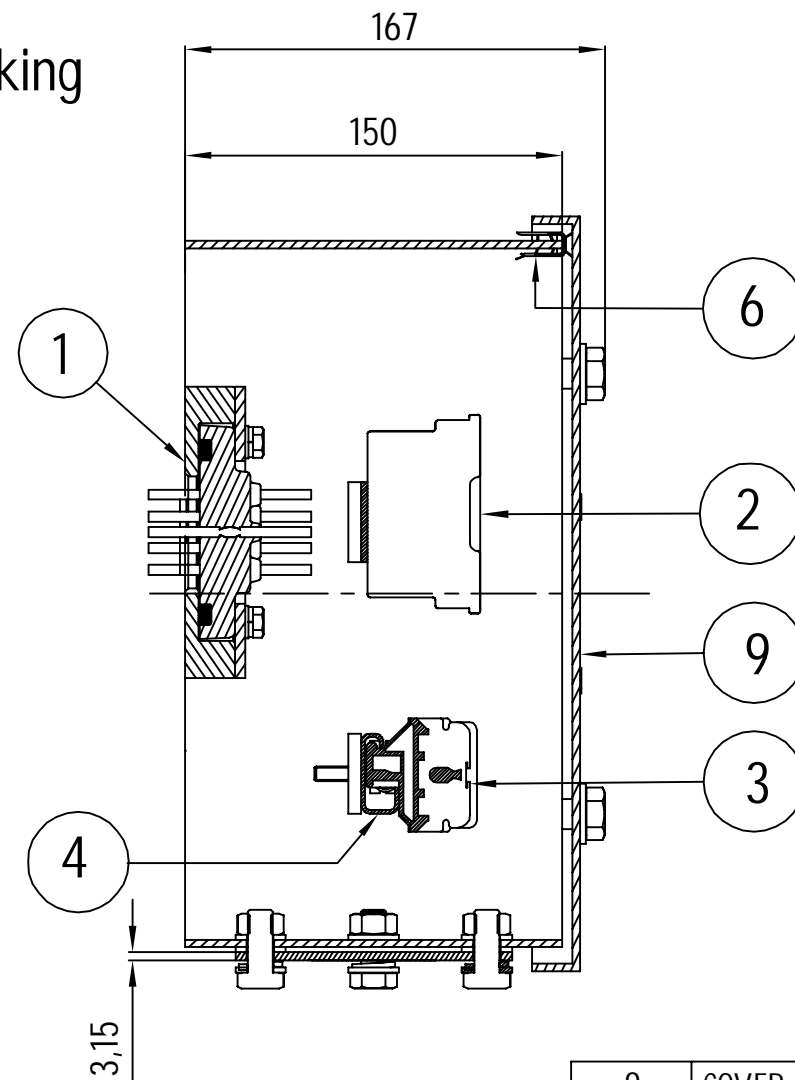
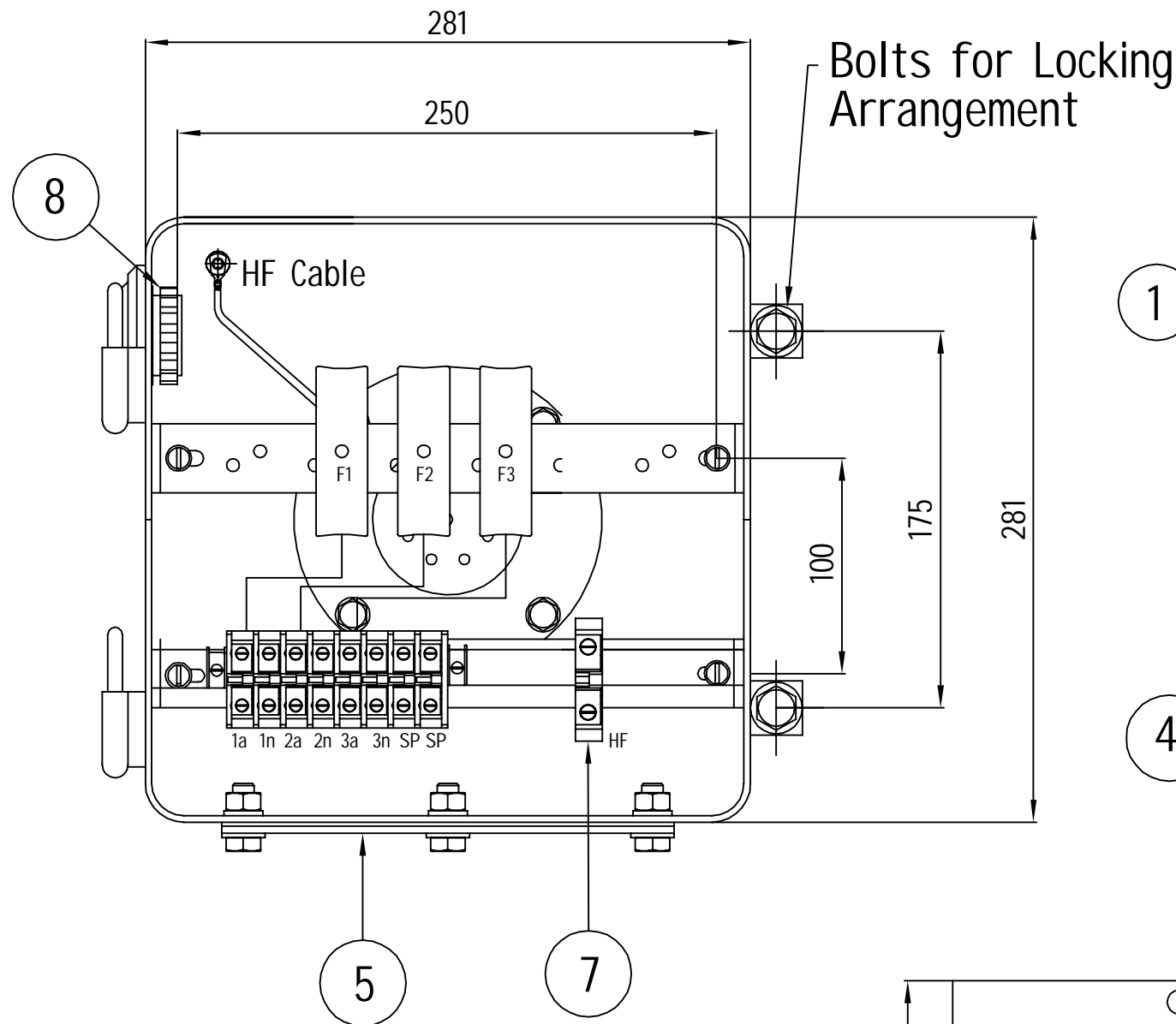

5. REMOVABLE UNDRILLED CABLE GLAND PLATE

**CHIEF ENGINEER
PLANNING & POWER SYSTEMS
APTRANSCO**

9	COVER
8	BREATHER
7	HF TERMINAL CONNECTION - OAT 25
6	EPDM GASKET
5	REMOVABLE UNDRILLED CABLE GLAND PLATE
4	TERMINAL MOUNTING CHANNEL
3	TERMINALS ELMEX MAKE CAT M4
2	HRC. FUSES (16AMP)
1	SECONDARY WINDING TERMINALS & HF BUSHING
Sr. No.	Item Description

- Minimum 300mm plinth shall be maintained for CT/PT/CVT/Isolators/IV/LA/Breakers in the Substation during foundation works to ensure safe live to ground clearance as per IE rules.
- Since the supply of terminal connectors is not in the scope of manufacturer as mentioned in the drawings. The EPC contractor shall be instructed to supply the same in line with CT/PT/CVT/Isolator/IVT/LA/Breakers requirement and compatibility.

NOTES:

- 1) DEGREE OF PROTECTION IP-55.
- 2) ALL FERROUS PARTS ARE HOT DIP GALVANIZED.
- 3) STEEL SHEET 3.15mm THICK HOT ROLLED.
- 4) ALL DIMENSIONS ARE IN mm.

This drawing is a COMPUTER ORIGINAL and does not require signatures for its authentication

Revision Details:
(B) Gland plate view added

Revision Details:
(A) New drg. prepared.

We reserve all rights in this document and in the information contained there in. Reproduction, use or disclosure to third parties without express authority is strictly forbidden © ABB.

Revision		245 KV Capacitor Voltage Transformer Type: CPB-H 245	SECONDARY TERMINAL BOX	DRAWN: SR	CHECKED: SNP	APPRD.: SN	file: 3320-059	TOTAL SH. 1
A	2022-06-09			ABB HITACHI ENERGY INDIA LIMITED (FORMERLY KNOWN AS APPSIL)			1HYT903320-059	Sh. NO. 1
B	2022-06-28							

NOTE: 1. DRAWING APPROVAL SUBJECT TO VALID TYPE TEST REPORTS, TO BE CHECKED DURING ACCEPTANCE TESTS
2. FOR EPC CONTRACTS ONLY

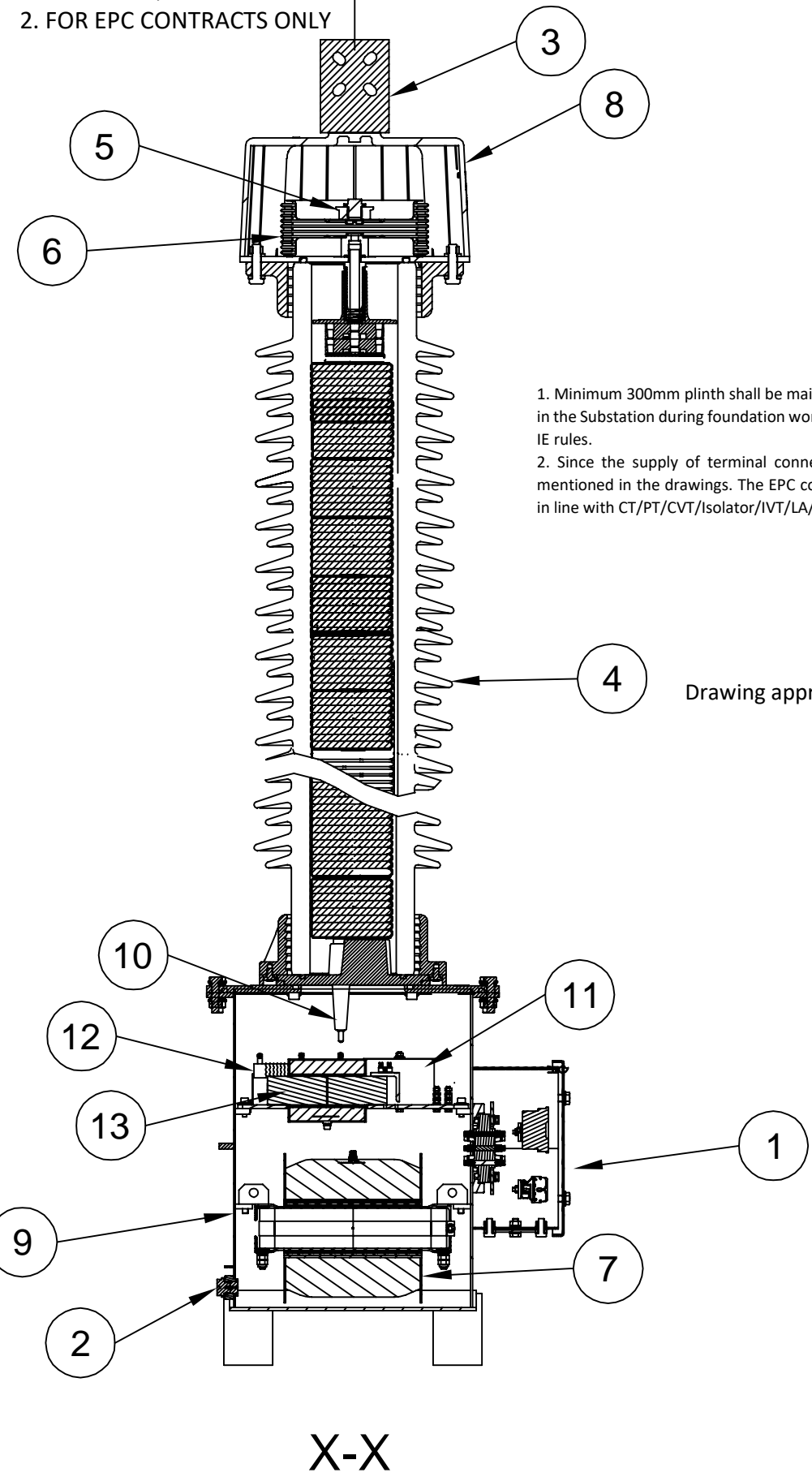

- Notes:
1. All exposed ferrous parts including tank are hot dip galvanized.
 2. Connect the HF Terminal to Earth when carrier coupling device is not used.
 3. All Dimensions are in mm. General Tolerance as per ISO:2768-C.
 4. Porcelain insulators with maximum one joint.
 5. CVD bellow material: Stainless Steel

1. Minimum 300mm plinth shall be maintained for CT/PT/CVT/Isolators/IV/LA/Breakers in the Substation during foundation works to ensure safe live to ground clearance as per IE rules.
2. Since the supply of terminal connectors is not in the scope of manufacturer as mentioned in the drawings. The EPC contractor shall be instructed to supply the same in line with CT/PT/CVT/Isolator/IVT/LA/Breakers requirement and compatibility.

Drawing approval subject to valid vendor registration

**CHIEF ENGINEER
PLANNING & POWER SYSTEMS
APTRANSCO**

13	Compensating reactor	1
12	Damping resistor.	1
11	Damping reactor	1
10	Mono Bushing	1
9	EMU tank	1
8	Top cover	1
7	Intermediate Voltage transformer	1
6	Bellow	1
5	Oil Filling Plug (Not to be Opened as hermetically sealed)	1
4	Insulator	1
3	Primary Terminal	1
2	Oil Drain Plug	1
1	Secondary Terminal Box	1
Sr. No.	Description	Quantity

This drawing is a COMPUTER ORIGINAL and does not require signatures for its authentication

Revision Details:
A New drg. prepared.

We reserve all rights in this document and in the information contained there in. Reproduction, use or disclosure to third parties without express authority is strictly forbidden © ABB.

Revision		245 KV Capacitor Voltage Transformer Type: CPB-H 245	SECTIONAL VIEW	DRAWN: SR	CHECKED: SNP	APPRD.: SN	file: 3320-060	TOTAL SH. 1
A	2022-06-09			HITACHI ENERGY INDIA LIMITED (FORMERLY KNOWN AS APPSIL)			1HYT903320-060	Sh. NO. 1

NOTE: 1. DRAWING APPROVAL SUBJECT TO VALID TYPE TEST REPORTS, TO BE CHECKED DURING ACCEPTANCE TESTS
2. FOR EPC CONTRACTS ONLY

1. Minimum 300mm plinth shall be maintained for CT/PT/CVT/Isolators/IV/LA/Breakers in the Substation during foundation works to ensure safe live to ground clearance as per IE rules.
2. Since the supply of terminal connectors is not in the scope of manufacturer as mentioned in the drawings. The EPC contractor shall be instructed to supply the same in line with CT/PT/CVT/Isolator/IVT/LA/Breakers requirement and compatibility.

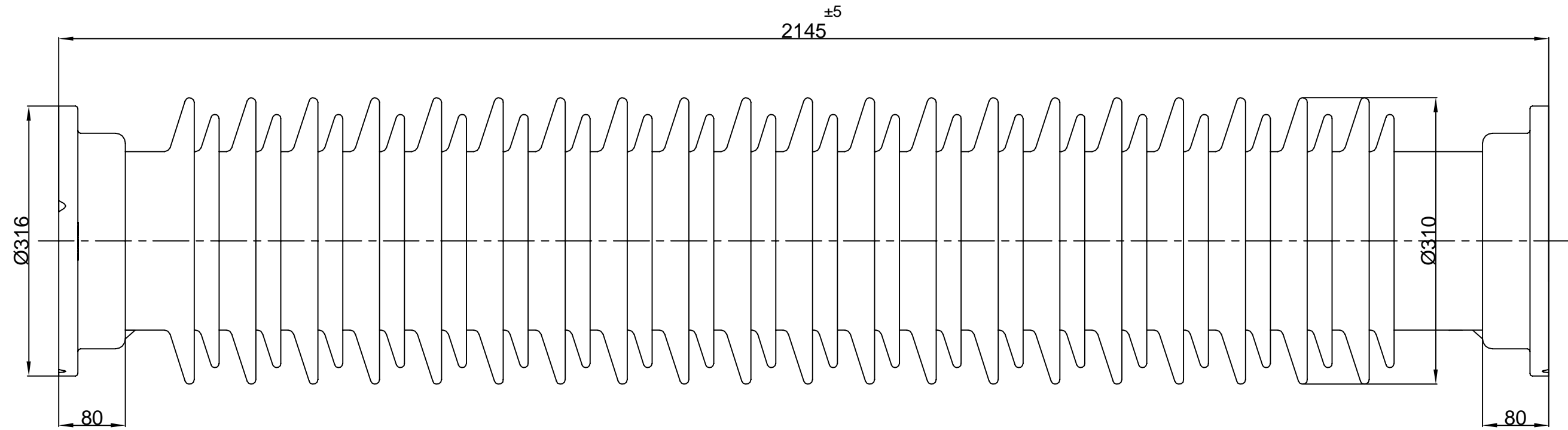

Drawing approval subject to valid vendor registration

- A) CEMENT COMPOUND SHOULD NOT STICK ON INSULATOR END OUTER CHAMFER AS WELL AS SEALING SURFACE
- B) THE OUTER SURFACE OF FLANGES SHALL BE WITH COLOURLESS ANODIZING OF 5 um THICKNESS MIN. THE ANODIZING SHALL NOT BE DONE ON SURFACE MARKED WITH CHAIN DOTTED LINE (i.e., ALONG SEALING SURFACE)
- C) PLEASE REFER SH.2 FOR SHED PROFILE AND ITS DETAIL
- D) THE TOTAL CREEPAGE DISTANCE SHALL BE 6125 mm MIN.
- E) CANTILEVER STRENGTH: 400 Kg

Ref Standard IEC 62155/IS 5621

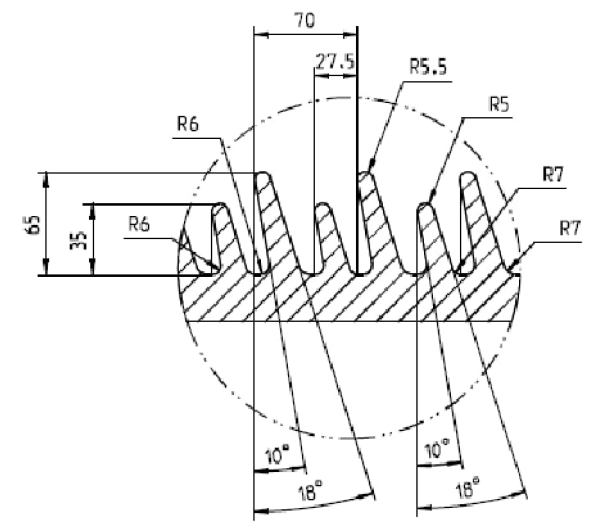

27 long and 27 short sheds

**CHIEF ENGINEER
PLANNING & POWER SYSTEMS
APTRANSCO**

This drawing is a COMPUTER ORIGINAL for its authentication and does not require signatures

Revision Details:
ⓐ Cantilever strength added

Revision Details:
ⓐ New drawing prepared.

We reserve all rights in this document and in the information contained there in. Reproduction, use or disclosure to third parties without express authority is strictly forbidden ©ABB.

Revision		245 kV Capacitor Voltage Transformer Type: CPB-H 245	INSULATOR DRAWING (25 mm/kV)	DRAWN: SR	CHECKED: PDS	APPRD.: SN	file: - 3320-072	TOTAL SH. 1
A	2022-06-09			HITACHI ENERGY INDIA LIMITED (FORMERLY KNOWN AS APPSIL)			1HYT903320-072	Sh. NO.
B	2022-06-29							1

6086466/2022/EEMRT-ENE51

REPORTS TO BE CHECKED DURING ACCEPTANCE TESTS

2. FOR EPC CONTRACTS ONLY

GUARANTEED TECHNICAL PARTICULARS FOR 220kV CAPACITOR VOLTAGE TRANSFORMERS

1	Name of the Manufacturer	Hitachi Energy India Limited
2	Type Designation	CPB-H 245
3	Type of CVT	Outdoor, Oil filled, Hermetically sealed
4	Rated Primary Voltage (kV)	220/ $\sqrt{3}$
5	Highest Service Voltage (kV)	245
6	Rated Voltage factor	1.2 Continuous & 1.5 for 30 Sec.
7	Rated Frequency (Hz)	50
8	Number of Phases	Single
9	Power frequency voltage withstand for 1 minute (kV rms)	460
10	Lightning Impulse voltage withstand for 1.2/50 μ s (kV peak)	1050
11	Switching Impulse voltage withstand for 250/2500 μ s (kV peak)	NA
12	Power frequency voltage withstand of secondary winding	3 kV for 1 Minute
13	Power frequency voltage withstand of H.F. Terminal	4 kV for 1 Min. (for Enclosed Type)
14	Equivalent series resistance over entire carrier frequency range (Ohm)	<40
15	Standards Applicable	IEC-61869-5
16	Temperature rise over ambient temperature at 50 °C	According to IEC: 61869-5 /IEC:186 / IS:3156
17	Radio interference voltage at 1 MHz at 1.1Um/ $\sqrt{3}$ (μ V)	<1000
18	Whether CVTs are suitable for Carrier Communication, Carrier Teleprinting services, Metering, Relaying, Protection, Synchronizing and Interlocking purposes ?	Yes
19	Capacitance values (pF)	4400 (+10% -5%)
20	Natural frequency of coupling / Self Tuning frequency (kHz)	\geq 500
21	Band width (kHz)	40 to 500
22	Values of stray capacitance and stray conductance in the carrier frequency range of 40 to 500 kHz	300 + 0.05C _n (pF) and 50 μ S (As per IEC:60358)
23	Capacitance Temp coefficient (% per kelvin)	0.07 %
24	Rated intermediate voltage of CVT (kV)	23/ $\sqrt{3}$
25	Rated primary voltage of EMU (kV)	23/ $\sqrt{3}$
26	Tan Delta value	<0.005
27	Type of Insulator	Porcelain
28	Mounting details (mm)	365x365
29	Over all height (mm)	3154 \pm 25
30	Standard range of frequencies for which accuracy are valid	As per IEC 61869-5 (96% to 102% for protection) (99 % to 101% for metering)
31	Min. creepage distance (mm/kV)	25
32	Total Weight (kg)	460 approx.
33	Quantity of oil (kg)	84 approx.
34	Surface finish of all ferrous parts	Mild Steel – Hot Dip Galvanized
35	Type & Material of terminal pad	Flat type, Aluminum
36	Provision made for accepting the change in oil volume?	Metal Bellows
37	Partial Discharge (pC)	<10 at Um, <5 at 1.2 Um/ $\sqrt{3}$
38	EMU oil	Mineral oil (As per IEC:60296)
39	CVD oil	Synthetic oil (As per IEC:60867)
40	Seismic acceleration	0.36g
41	Type of insulation	A

**CHIEF ENGINEER
PLANNING & POWER SYSTEMS
APTRANSCO**

**6086466/2022/EEMRT-ENE51 GUARANTEED TECHNICAL PARTICULARS
FOR 220kV CAPACITOR VOLTAGE TRANSFORMERS**

NOTE: 1. DRAWING APPROVAL SUBJECT TO VALID TYPE TEST
REPORTS, TO BE CHECKED DURING ACCEPTANCE TESTS

Winding Details 2. FOR EPC CONTRACTS ONLY

Sr.No.	Parameter	Wdg I	Wdg II	Wdg III
1	Rated Secondary Voltage (v)	$110/\sqrt{3}$	$110/\sqrt{3}$	$110/\sqrt{3}$
2	Accuracy Class	3P	3P	0.2
3	Rated Burden	50 VA	50 VA	50 VA
4	Simultaneous Burden	50VA for 0.2 & 100 VA for 3P		
5	Rated Thermal Burden	750 VA		

1. Minimum 300mm plinth shall be maintained for CT/PT/CVT/Isolators/IV/LA/Breakers in the Substation during foundation works to ensure safe live to ground clearance as per IE rules.

2. Since the supply of terminal connectors is not in the scope of manufacturer as mentioned in the drawings. The EPC contractor shall be instructed to supply the same in line with CT/PT/CVT/Isolator/IVT/LA/Breakers requirement and compatibility.

**CHIEF ENGINEER
PLANNING & POWER SYSTEMS
APTRANSCO**

Drawing approval subject to valid vendor registration