

MOUNTING DETAIL

NOTE: 1. DRAWING APPROVAL SUBJECT TO VALID TYPE TEST REPORTS, TO BE CHECKED DURING ACCEPTANCE TESTS
2. FOR EPC CONTRACTS ONLY

NOTES :

1. ALL FERROUS PARTS EXPOSED TO THE ATMOSPHERE SHALL BE PAINTED WITH P.U PAINT SHADE 631 OF IS: 5.
2. MAKE OF BUSHING: IEC/MODERN/BHEL/ABIL/CJI
3. TOTAL CREEPAGE DISTANCE :- 6125 mm (MIN)
4. QUANTITY OF OIL :-250 LITRES APPROX.
5. TOTAL WEIGHT OF PT : 1000 KGS APPROX.
6. ALL HARDWARE SHALL BE HOT DIP GALVANIZED.
7. TRANSFORMER OIL AS PER IEC : 60296.
8. ALL GASKETS SHALL BE FIXED IN PROPERLY MACHINED GROOVES.
9. ALL GASKETS SHALL BE MADE OF NITRILE BUTYL RUBBER.

S.No.	DESCRIPTION	QTY	MATL
1	H.T TERMINAL	1	COPPER NICKEL PLATED
2	OIL LEVEL INDICATOR	1	AL./BRASS
3	OIL EXPANSION CHAMBER	1	M.S
4	BUSHING FLANGE (CEMENTED)	2	GI/CI
5	BUSHING	1	PORCELAIN
6	LIFTING LUG	4	M.S
7	NAME AND RATING PLATE	1	AL. Anodised
8	TANK WITH COVER	1	M.S
9	OIL DRAIN PLUG	1	M.S
10	EARTHING FLAT 80x50x8 Thick.	2	M.S
11	SECONDARY & EARTHING TERMINAL BOX	1	M.S
12	DOME	1	M.S/AL.
13	OIL FILLING PORT	1	M.S
14	BELLOW	1	S.S
15	BUSHING FLAT GASKET	2	N.B.R

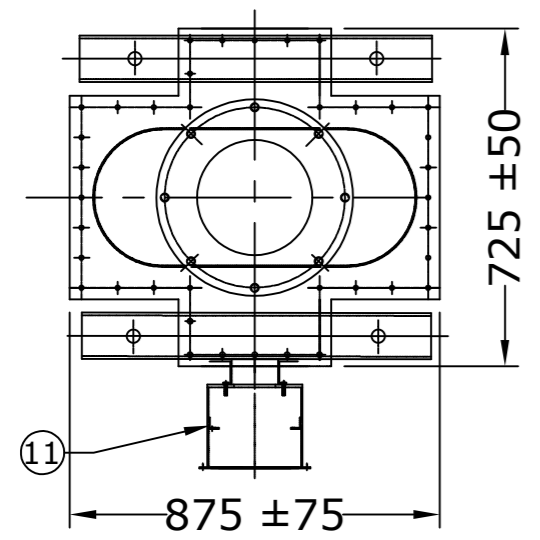

**CHIEF ENGINEER
POWER SYSTEMS, PLANNING & DESIGN
APTRANSCO**

R0	FOR APPROVAL	06.01.2021
REV.	REVISION DESCRIPTION	DATED INITIALS

CLIENT : TRANSMISSION CORPORATION OF ANDHRA PRADESH LIMITED
PROJECT NAME : AS APPLICABLE

UNLESS OTHERWISE SPECIFIED	DATE	NAME	MATERIAL
1. ALL DIMENSIONS ARE IN mm.	DGN. 06.01.2021	SPS	AS ABOVE
2. TOLERANCE WHEREVER NOT INDICATED ±5%	DRN. 06.01.2021	AKASH	
	CHD. 06.01.2021	BLS	
SCALE:	N.T.S		

TITLE :
GENERAL ARRANGEMENT DRAWING FOR 220KV INDUCTION VOLTAGE TRANSFORMER

MEHRU
MEHRU ELECTRICAL & MECHANICAL ENGINEERS (P) LTD.

DRG.NO
ME-220IVT-GA-02

Drawing approval subject to valid vendor registration

SHEET No.
1 OF 7

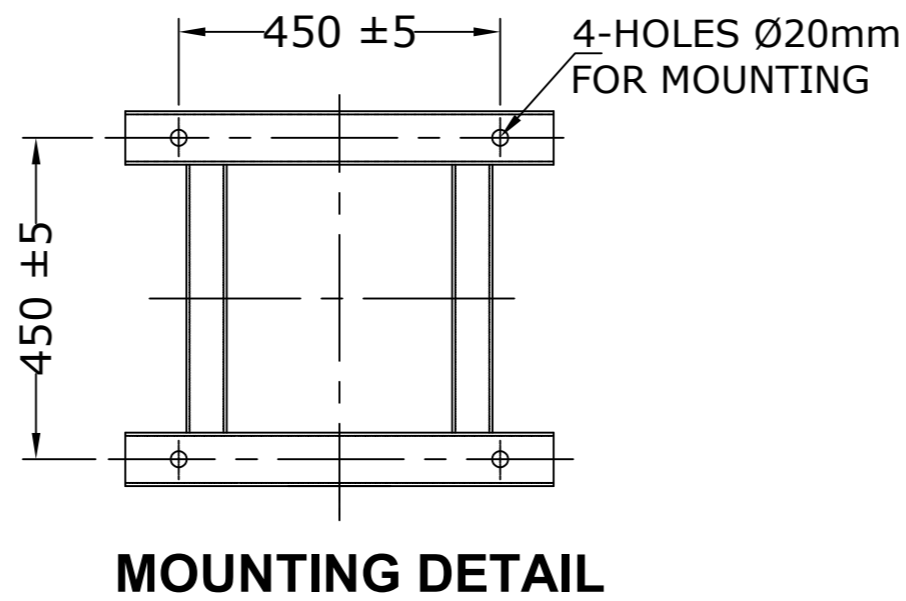
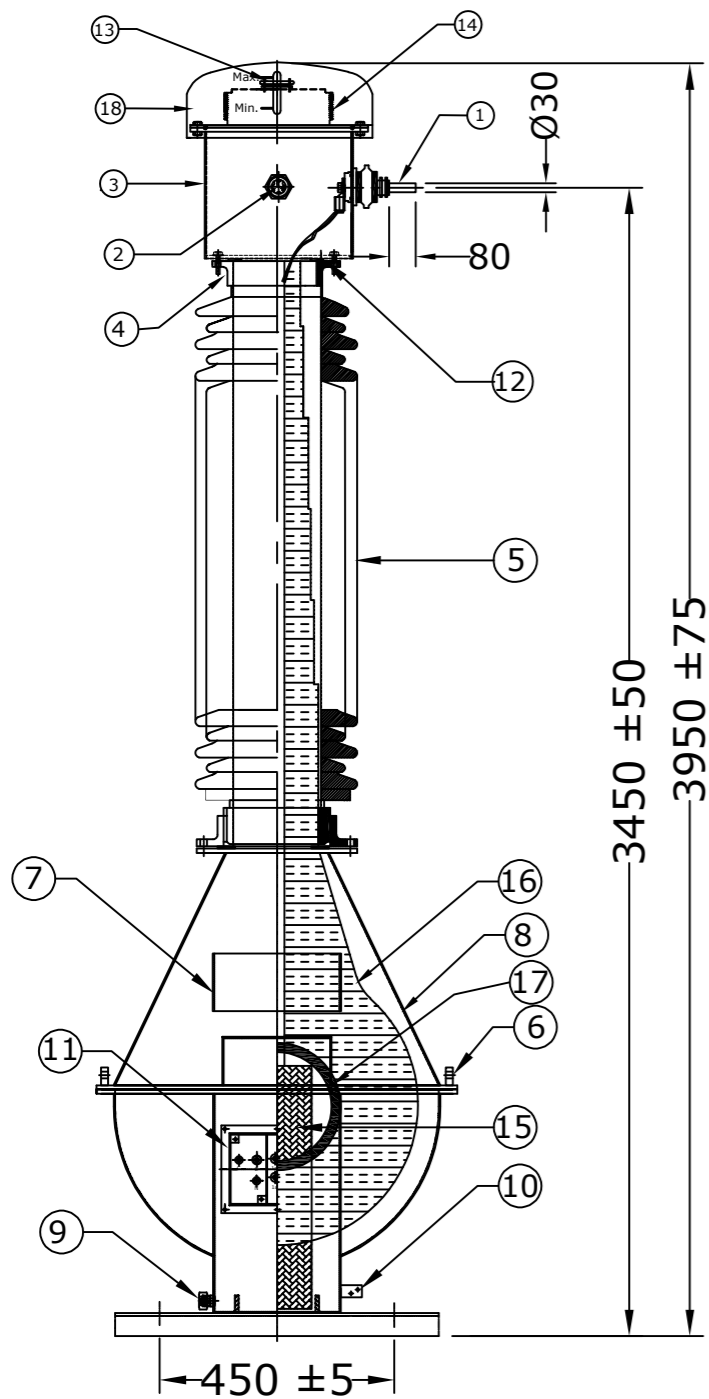

MOUNTING DETAIL

S.No.	DESCRIPTION	QTY	MATL
1	H.T TERMINAL	1	COPPER NICKEL PLATED
2	OIL LEVEL INDICATOR	1	AL./BRASS
3	OIL EXPANSION CHAMBER	1	M.S
4	BUSHING FLANGE (CEMENTED)	2	GI/CI
5	BUSHING	1	PORCELAIN
6	LIFTING LUG	4	M.S
7	NAME AND RATING PLATE	1	AL.Anodised
8	TANK WITH COVER	1	M.S
9	OIL DRAIN PLUG	1	M.S
10	EARTHING FLAT 80x50x8 Thick.	2	M.S
11	SECONDARY & EARTHING TERMINAL BOX	1	M.S
12	BUSHING FLAT GASKET	2	N.B.R
13	OIL FILLING PORT	1	M.S
14	BELLOW	1	S.S
15	STACK LAMINATION		CRGO
16	HT COIL WITH PAPER INSULATION	1	COPPER
17	LT COIL WITH PAPER INSULATION	1	COPPER
18	DOME	1	M.S/AL.

NOTES :

1. ALL FERROUS PARTS EXPOSED TO THE ATMOSPHERE SHALL BE PAINTED WITH P.U PAINT SHADE 631 OF IS: 5.
2. MAKE OF BUSHING: IEC/MODERN/BHEL/ABIL/CJI
3. TOTAL CREEPAGE DISTANCE :- 6125 mm (MIN)
4. QUANTITY OF OIL :-250 LITRES APPROX.
5. TOTAL WEIGHT OF PT : 1000 KGS APPROX.
6. ALL HARDWARE SHALL BE HOT DIP GALVANIZED.
7. TRANSFORMER OIL AS PER IEC : 60296.
8. ALL GASKETS SHALL BE FIXED IN PROPERLY MACHINED GROOVES.
9. ALL GASKETS SHALL BE MADE OF NITRILE BUTYL RUBBER.

Drawing approval subject to valid vendor registration

- NOTE: 1. DRAWING APPROVAL SUBJECT TO VALID TYPE TEST REPORTS, TO BE CHECKED DURING ACCEPTANCE TESTS
2. FOR EPC CONTRACTS ONLY

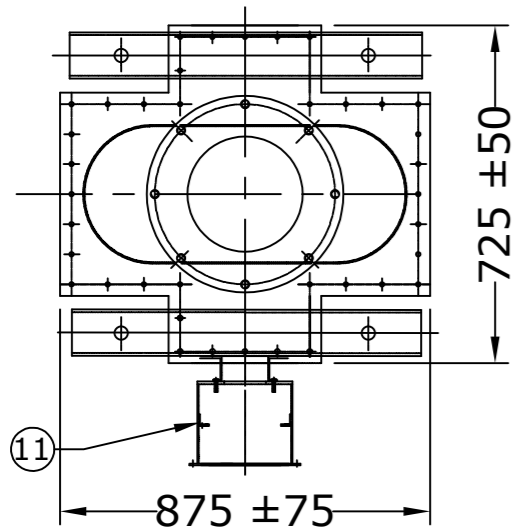

**CHIEF ENGINEER
POWER SYSTEMS, PLANNING & DESIGN
APTRANSCO**

RO	FOR APPROVAL	06.01.2021
REV.	REVISION DESCRIPTION	DATED INITIALS

CLIENT : TRANSMISSION CORPORATION OF ANDHRA PRADESH LIMITED				<p>MEHRU MEHRU ELECTRICAL & MECHANICAL ENGINEERS (P) LTD.</p>
PROJECT NAME : AS APPLICABLE				
UNLESS OTHERWISE SPECIFIED	DATE	NAME	MATERIAL	
1. ALL DIMENSIONS ARE IN mm. 2. TOLERANCE WHEREVER NOT INDICATED ±5%	DGN. 06.01.2021 DRN. 06.01.2021 CHD. 06.01.2021 SCALE: N.T.S	SPS AKASH BLS	AS ABOVE	
TITLE :				
SECTIONAL ARRANGEMENT DRAWING FOR 220KV INDUCTION VOLTAGE TRANSFORMER				
SHEET No. 2 OF 7				DRG.NO ME-220IVT-SE-02



INDUCTION VOLTAGE TRANSFORMER

SR.No.		REF.STD.	IS: 16227
TYPE	Outdoor Oil Cooled	RATIO	220 kV / $\sqrt{3}$
Highest System Voltage	245 kV		110V/ $\sqrt{3}$
PHASE	Single	BURDEN	10 VA
Insulation level	460/1050 kV	CLASS	0.2
Thermal Burden	10 VA	Simultaneous Burden	10 VA
Frequency	50 Hz	Type	Earthed
Voltage Factor	1.2	TIME CONT. &	1.5
		TIME FOR	30 Sec
		YEAR OF MFG.	2021

* QUANTITY OF OIL 250 LTRS. APPROX.

* TOTAL WEIGHT 1000 Kgs. APPROX. * TOTAL CREEPAGE DISTANCE 6125 mm (Minimum)

MADE IN INDIA BY
MEHRU ELECTRICAL AND MECHANICAL ENGINEERS (P) LTD.
 SP-2/180, RIICO INDUSTRIAL AREA KHARANI EXT. BHIWADI-301019, RAJ. (INDIA)

SUITABLE FOR HOT LINE WASHING CONNECTION DIAGRAM

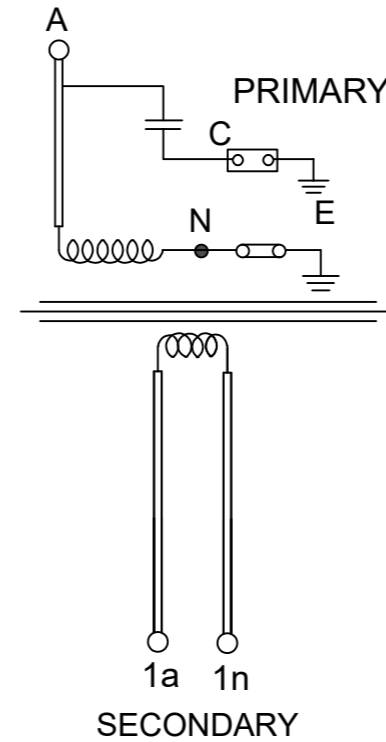

- CAUTION :**
1. KEEP OPEN ALL SECONDARIES TERMINALS ARE NOT IN USE.
 2. ALWAYS KEEP NEUTRAL TERMINAL 'N' AND TAN DELTA TESTING TERMINAL 'C' SHORTED TO EARTH DURING OPERATION
 3. DO NOT REMOVE EARTH LINK WHEN IN OPERATION.

115 ±10

195 ±15

NOTES:-

1. THICKNESS OF RATING PLATE 1.2 mm
2. MATERIAL OF NAME PLATE SHALL BE AL. ANODIZED.
3. SERIAL NUMBER SHALL BE ENGRAVING BEFORE THE DISPATCH.

Drawing approval subject to valid vendor registration

- NOTE:** 1. DRAWING APPROVAL SUBJECT TO VALID TYPE TEST REPORTS, TO BE CHECKED DURING ACCEPTANCE TESTS
 2. FOR EPC CONTRACTS ONLY

CLIENT : TRANSMISSION CORPORATION OF ANDHRA PRADESH LIMITED				<p>MEHRU ELECTRICAL & MECHANICAL ENGINEERS (P) LTD.</p>
PROJECT NAME : AS APPLICABLE				
UNLESS OTHERWISE SPECIFIED	DATE	NAME	MATERIAL	
1. ALL DIMENSIONS ARE IN mm. 2. TOLERANCE WHEREVER NOT INDICATED ±5%	DGN. 06.01.2021 DRN. 06.01.2021 CHD. 06.01.2021 SCALE: N.T.S	SPS AKASH BLS	AL.ANODIZED	
TITLE :				
NAME PLATE DRAWING FOR 220KV INDUCTION VOLTAGE TRANSFORMER				
SHEET No.		3 OF 7		DRG.NO ME-220IVT-NP-02

CHIEF ENGINEER
POWER SYSTEMS, PLANNING & DESIGN
APTRANSCO

REV.	REVISION DESCRIPTION	DATED INITIALS
R0	FOR APPROVAL	06.01.2021

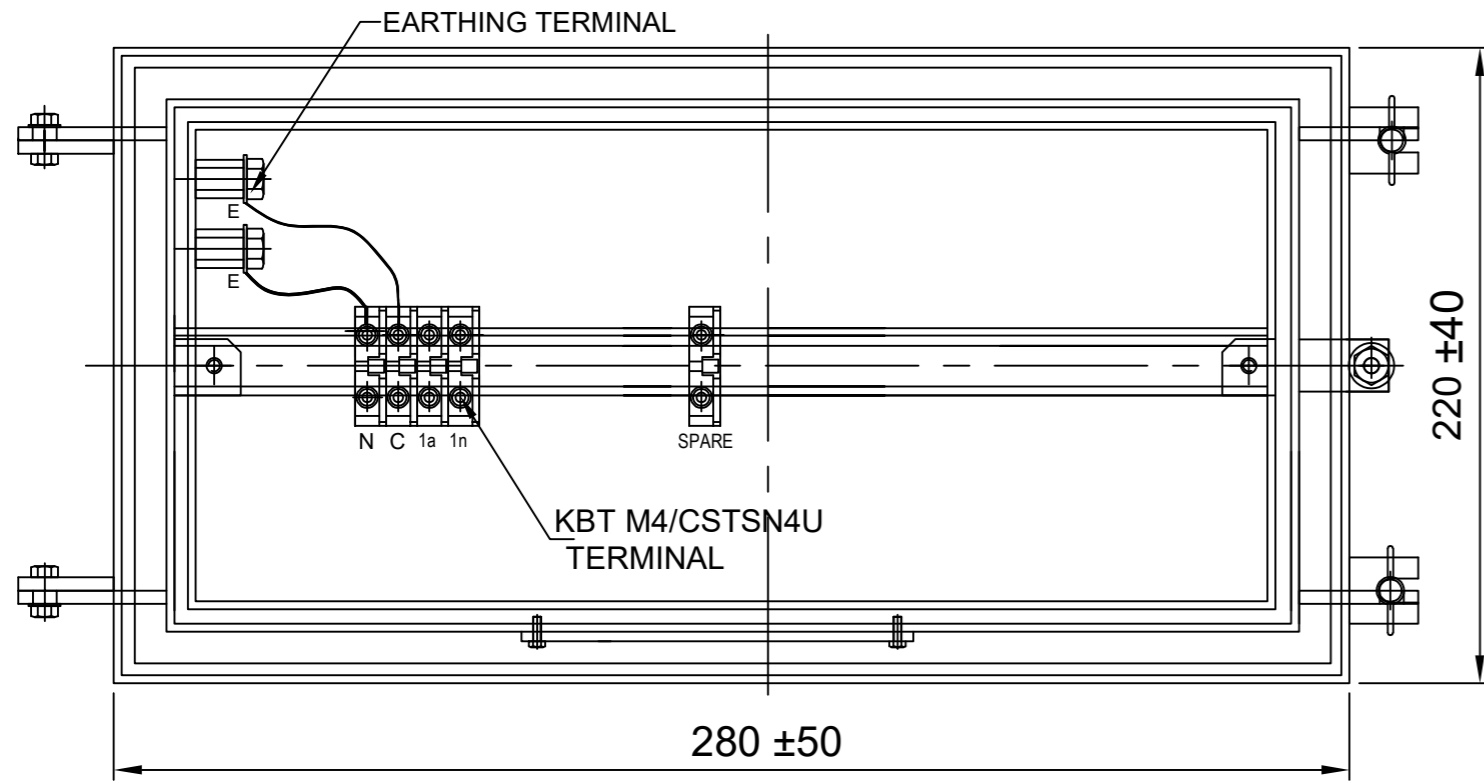

FRONT VIEW

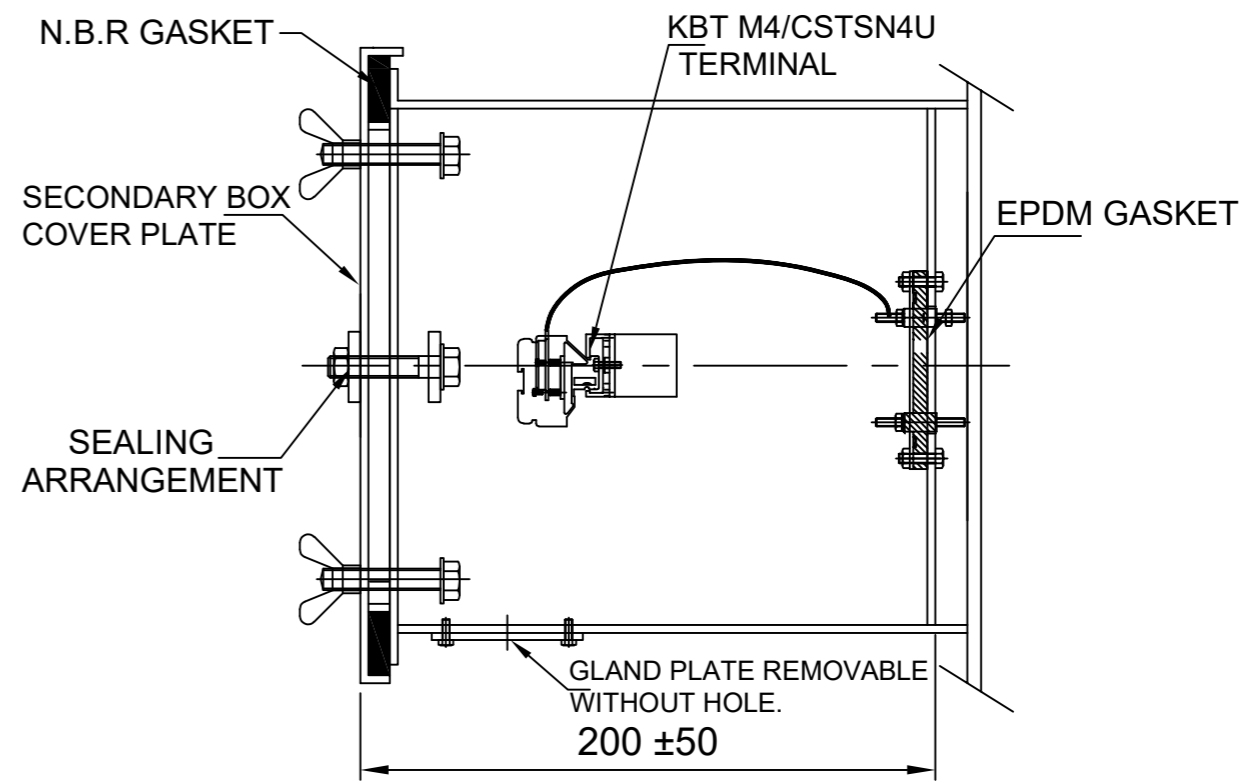

SIDE VIEW

'N' : NEUTRAL TERMINAL
'C': TAN DELTA TESTING TERMINAL

NOTES:-

1. SECONDARY TERMINAL BOX SHALL BE PROVIDED REMOVABLE GLAND PLATE WITHOUT HOLE.
2. SECONDARY TERMINAL BOX SHALL BE PROVIDED WITH COVER.
3. M.S SHEET THICKNESS FOR TERMINAL BOX 3.0mm. & FOR COVER 2.0mm.
4. MATERIAL OF GASKET: NITRILE BUTYL RUBBER GASKET.
5. DEGREE OF PROTECTION : IP 55
6. 20% SPARE TERMINAL SHALL BE PROVIDED.

NOTE: 1. DRAWING APPROVAL SUBJECT TO VALID TYPE TEST REPORTS, TO BE CHECKED DURING ACCEPTANCE TESTS
2. FOR EPC CONTRACTS ONLY

Drawing approval subject to valid vendor registration

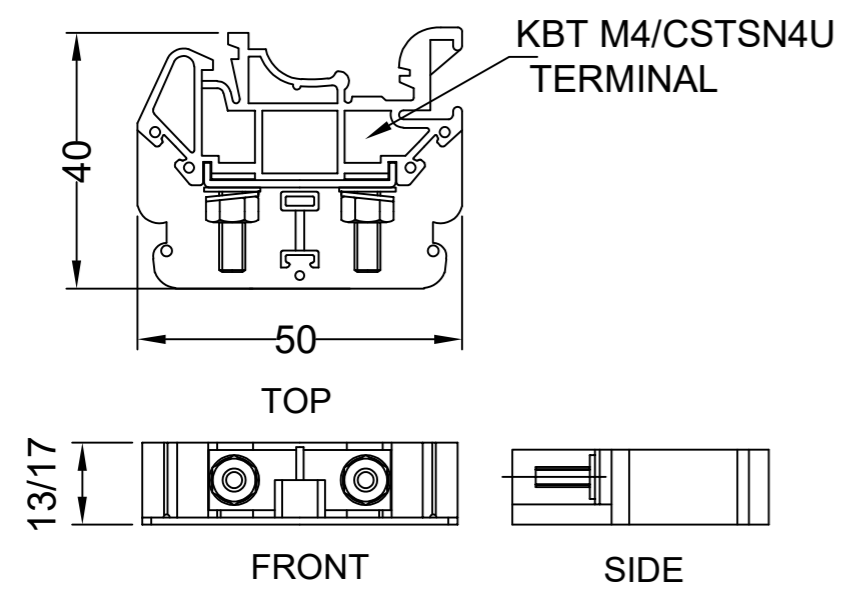

MATERIAL: POLYAMIDE
MAKE: ELMEX/CONNECTWELL
TERMINAL (DETAIL)

**CHIEF ENGINEER
POWER SYSTEMS, PLANNING & DESIGN
APTRANSCO**

REV.	REVISION DESCRIPTION	DATED INITIALS
R0	FOR APPROVAL	06.01.2021

CLIENT : TRANSMISSION CORPORATION OF ANDHRA PRADESH LIMITED				PROJECT NAME : AS APPLICABLE		
UNLESS OTHERWISE SPECIFIED 1. ALL DIMENSIONS ARE IN mm. 2. TOLERANCE WHEREVER NOT INDICATED ±5%	DATE	NAME	MATERIAL M.S	MEHRU MEHRU ELECTRICAL & MECHANICAL ENGINEERS (P) LTD.		
	DGN.	06.01.2021				SPS
	DRN.	06.01.2021				AKASH
	CHD.	06.01.2021				BLS
SCALE:	N.T.S		TITLE : SECONDARY TERMINAL BOX DRAWING FOR 220KV INDUCTION VOLTAGE TRANSFORMER			
SHEET No. 4 OF 7				DRG.NO ME-220IVT-STB-02		

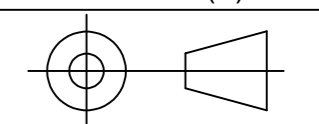

GUARANTEE TECHNICAL PARTICULAR 220kV INDUCTIVE VOLTAGE TRANSFORMER		
S. NO	DESCRIPTION	245 kv
1	Type	Mehru Electrical & Mechanical Engineers (P) Ltd, Bhiwadi, (Raj), Inida
2	Manufacturer's type designation	Outdoor, Oil Cooled, Electromagnetic Type, Inductive Voltage Transformer
3	Mounting of tank (bottom)	Bottom
4	System rated voltage/highest voltage (kv)	220/245
5	Rated primary voltage (kv)	220 kV/v3
6	Secondary winding details	Drawing approval subject to valid vendor registration
	(a) No. of secondary windings	1
	(b) Rated secondary voltage (V)	110 V/v3,
	(c) Rated burden VA (simultaneous)	10 VA
	(d) Class of accuracy	Wdg:1, 0.2,
7	Maximum ratio error with % rated burden and 5 % normal primary voltage	In limits as per IS 16227
8	Maximum phase angle error with % rated burden and 5 % normal primary voltage	In limits as per IS 16227

NOTE: 1. DRAWING APPROVAL SUBJECT TO VALID TYPE TEST

4714182/2021/EEMRT-ENES REPORTS, TO BE CHECKED DURING ACCEPTANCE TESTS

2. FOR EPC CONTRACTS ONLY

Drawing approval subject to valid vendor registration

9	Temperature rise at 1.1 times rated voltage with rated burden deg.C	50deg C
10	Rated voltage factor and time	1.2 continuous & 1.5 for 30 seconds
11	Temperature rise for item-10 above deg.C	Within limit as per IS 16227
12	Impulse withstand test voltage (kv) peak	1050
13	One minute power frequency withstand test voltage on secondary (kv rms)	3
14	One minute power frequency withstand test voltage on primary (kv rms)	460
15	Total creepage distance of the bushing mm	25 mm/kV i.e. 6125 mm
16	Grade of oil	EHV IS 335/IEC 60296
17	Quantity of insulating oil (Litres)	250 Ltr Approx
18	Weight of oil (kg)	200 kgs Approx
19	Total weight including oil (kg)	1000kG Approx
20	Whether sealed (if so type of sealing)	Yes, SS BELLOW
21	Over all dimensions	
	Height (mm)	3950±75 mm

NOTE: 1. DRAWING APPROVAL SUBJECT TO VALID TYPE TEST
 4714182/2021/EEMRT-ENE51 REPORTS, TO BE CHECKED DURING ACCEPTANCE TESTS
 2. FOR EPC CONTRACTS ONLY

	Length (mm)	450±5 mm
	Breadth (mm)	450±5 mm
	Weight of Steel	160 kgs (Approx.)
22	Wight of Aluminum	15 kgs (Approx.)
	Weight of copper	15 kgs (Approx.)
a)	Radio interference voltage	As per IS 16227 Clause 6.11.2 <2500uV
b)	Partial discharge level	<10 pC at Um & <5 pc at 1.2Um/√3
	Tan delta	<0.005

**CHIEF ENGINEER
 POWER SYSTEMS, PLANNING & DESIGN
 APTRANSCO**

Drawing approval subject to valid vendor registration