

This drawing is the property of Tritech Corporation and must not be passed on to any person or body not authorised by us to receive it nor be copied or otherwise made use either in full or in part by such person or body without our prior permission in writing.

NOTE:-1. Drawings approval subject to valid type test reports, to be checked during acceptance tests.
2. For EPC contractors only.

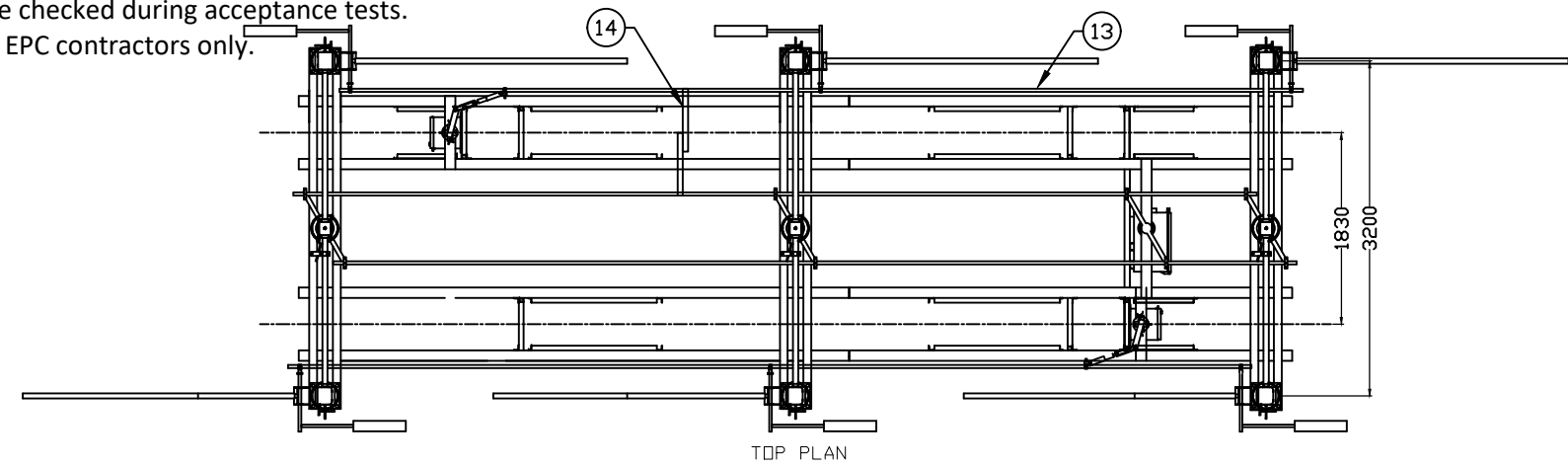

Drawing approval subject to valid vendor registration

SR.	PART LIST	MATERIAL	QTY/ISO
1	FIXED CONTACT ASSEMBLY	MS HDG	6 NOS.
2	MOVING CONTACT ASSEMBLY	MS HDG	3 NOS.
3	INSULATOR (NOT IN SCOPE OF TRITECH SUPPLY)	PORCELAIN	9 NOS.
4	TANDEM PIPE (NB 32 G.I. PIPE) 10 MTR	GI PIPE	2 NOS.
5	ROTATING INSULATOR POST	AL	3 NOS.
6	ELEVATOR PLATE-12MM	MS HDG.	6 NOS.
7	BASE CHANNEL (150X75X5)	MS HDG.	3 NOS.
8	OPERATING PIPE (NB 50 G.I. PIPE)	GI PIPE	1 NO.
9	MAIN OPERATING MECHANISM BOX (MOTOR)	AL	1 NO.
10	4TH BASE FOR MAIN DOP SUPPORT	MS HDG	1 NO.
11	E/S FIXED CONTACT ASSEMBLY	MS HDG	6 NOS.
12	E/S MOVING CONTACT ASSEMBLY	MS HDG	6 NOS.
13	E/S TANDEM PIPE (32 NB G.I. PIPE)	GI PIPE	2 NO.
14	MECHANICAL INTERLOCK	MS HDG	1 NO.
15	E/S LINK OPERATING MECHANISM	MS HDG	2 NO.
16	E/S OPERATING PIPE (50 NB G.I. PIPE)	GI PIPE	2 NO.
17	E/S OPERATING MECH. BOX (RED GEAR)	AL	2 NO.

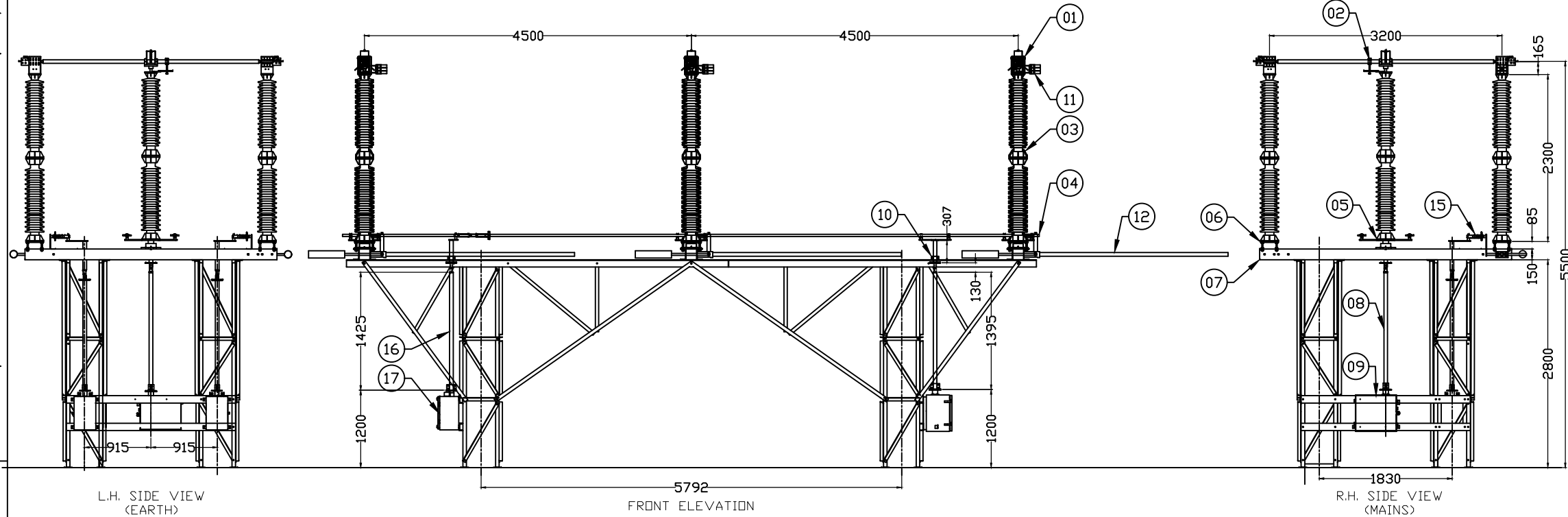

- NOTE:
- ALL DIMENSIONS ARE IN MM.
 - ALL FERROUS PARTS ARE HOT DIP GALVANIZED.(87 MICRONS)
 - ALL HDE COPPER CONTACT POINTS ARE SILVER PLATED (15 MICRONS.)
 - THE MAIN ROTATING POST HAS TWO NOS OF BALL BEARING.
 - ALL G.I. PIPES ARE OF 'B' CLASS
 - MANUFACTURING TOLERANCES:
 - I) UPTO 50MM - ±3%
 - II) 51MM TO 100MM - ±2%
 - III) 101MM TO 300MM - ±1%
 - IV) ABOVE 300MM - ±0.5%
 - WEIGHT OF METALLIC (APPX.) - 760 KGS
 - STRUCTURE & FOUNDATION BOLTS AND INSULATORS ARE NOT IN TRITECH SCOPE OF SUPPLY.
 - INSULATOR HAVING 225MM BOTTOM P.C.D. & 127MM TOP P.C.D.

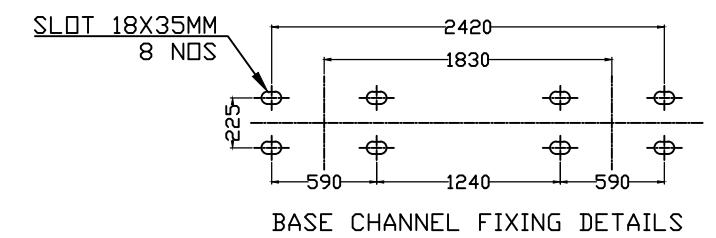
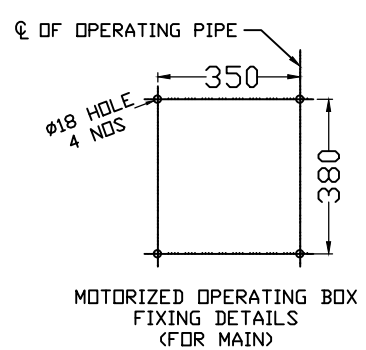
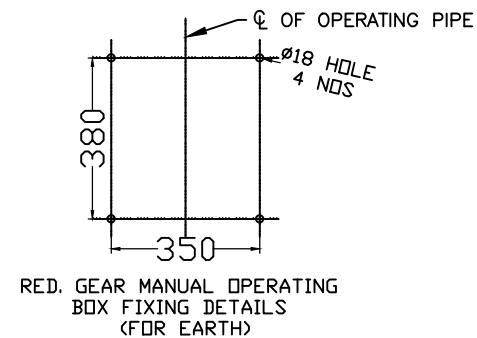
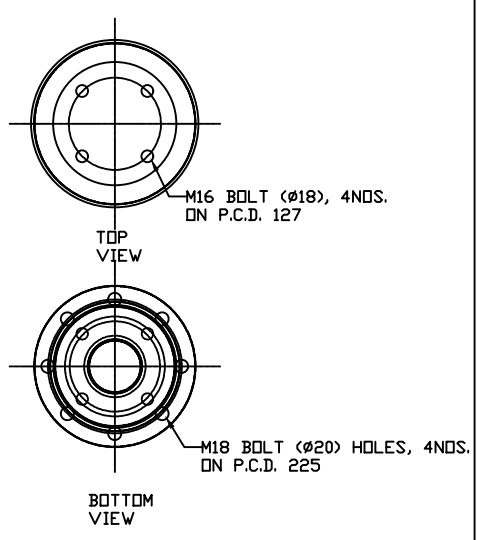

CHIEF ENGINEER/PROJECTS
APTRANSCO/VS/Vijayawada

REV NO	DATE	DESCRIPTION	SIGN

TRITECH DISCONNECTORS (INDIA) PVT. LTD.
DISCONNECTORS (INDIA) PVT.LTD
MANUFACTURER OF HV/ EHV ISOLATORS

NAME	SIGN	DATE	TITLE
DRWN SHARAD	SRD	19.03.23	G.A. DRAWING OF 245KV 1200AMP H.D.B. ISOLATOR WITH TWO EARTH SWITCH
CHKD P.SHELAR	PPS	19.03.23	
APPD P.SHELAR	PPS	19.03.23	

DWG. NO : I7123003AP
SIZE A4 SHEET : 1/1

This drawing is the property of TRITECH DISCONNECTORS (INDIA) PVT. LTD. and must not be passed on to any person or body not authorised by us to receive it nor be copied or otherwise made use either in full or in part by such person or body without our prior permission in writing.

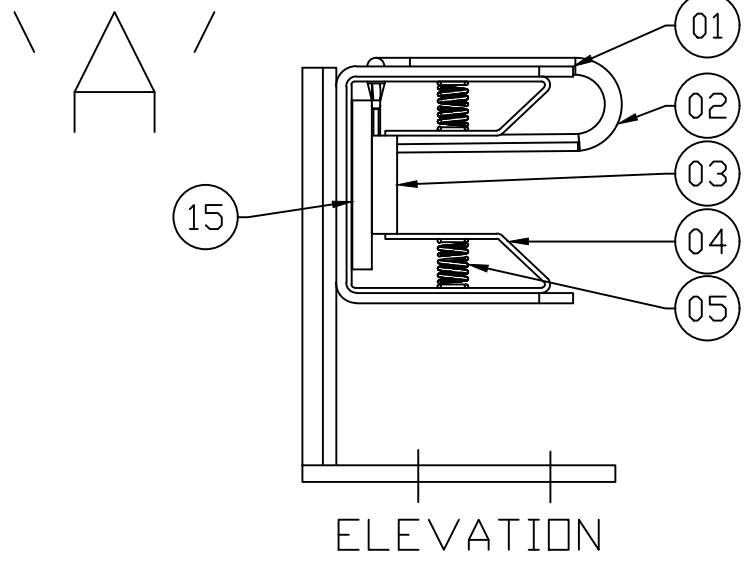

ELEVATION

NOTE:-1. Drawings approval subject to valid type test reports, to be checked during acceptance tests.
2. For EPC contractors only.

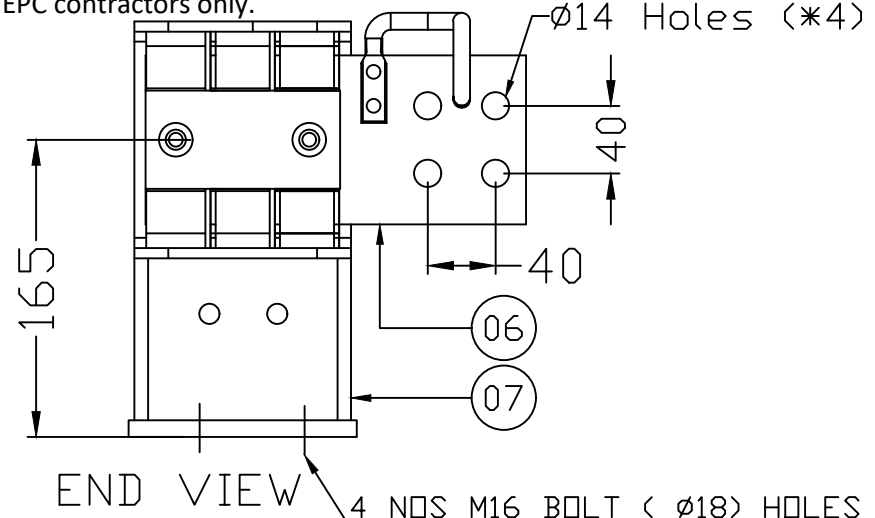

END VIEW

DETAILS OF FIXED CONTACT

SR.	PART LIST	MATERIAL	QTY/ISD
1	FC C BRACKET / RAINHOOD-6MM THK	MS HDG	6 NOS
2	FC ARCING HORN-Ø10MM	MS HDG	6 NOS
3	SPACER-10MM THK	BACKELITE	3 NOS
4	FC M CONTACT (32X4)	CU	18 NOS
5	FC SPRINGS	SS	36 NOS
6	TERMINAL PAD (100X12)	AL	6 NOS
7	SUPPORTING CHANNEL-4MM THK	MS HDG	6 NOS
8	MC CANOPY (0.5MM THK.)	AL	6 NOS
9	MC SUPPORTING BLOCK	AL	6 NOS
10	MC COPPER TUBE HDEC(ØD-50 ID-41)	CU	3 NOS
11	MC ARCING HORN Ø10MM	MS HDG	6 NOS
12	CLAMP FOR TURN & TWIST-5MM THK	MS HDG	3 NOS
13	MC BASE PLATE FOR TURN & TWIST	MS HDG	3 NOS
14	MC SPRING (SS)	SS	3NOS
15	BI-METALLIC SHEET 2MM THK	AL+CU	6NOS

4 NOS M16 BOLT (Ø18) HOLES ON 127 PCD

NOTE:

- ALL DIMENSIONS ARE IN MM.
- ALL FERROUS PARTS ARE HOT DIP GALVANIZED.(87 MICRONS)
- ALL HDE COPPER CONTACT POINTS ARE SILVER PLATED.(15 MICRONS)
- TOLERANCE AS PER G.A. DRAWING.
- FOR CONTACT DETAILS FIX CONTACT 'A' & MOVING CONTACT 'B' DETAILS REFER TABLE ANNEXURE 1
- MOVING CONTACT LENGTH AND FIX CONTACT WILL VARY AS PER FIX CONTACT PAIRS REQUIRED AS PER ANNEXURE 1.

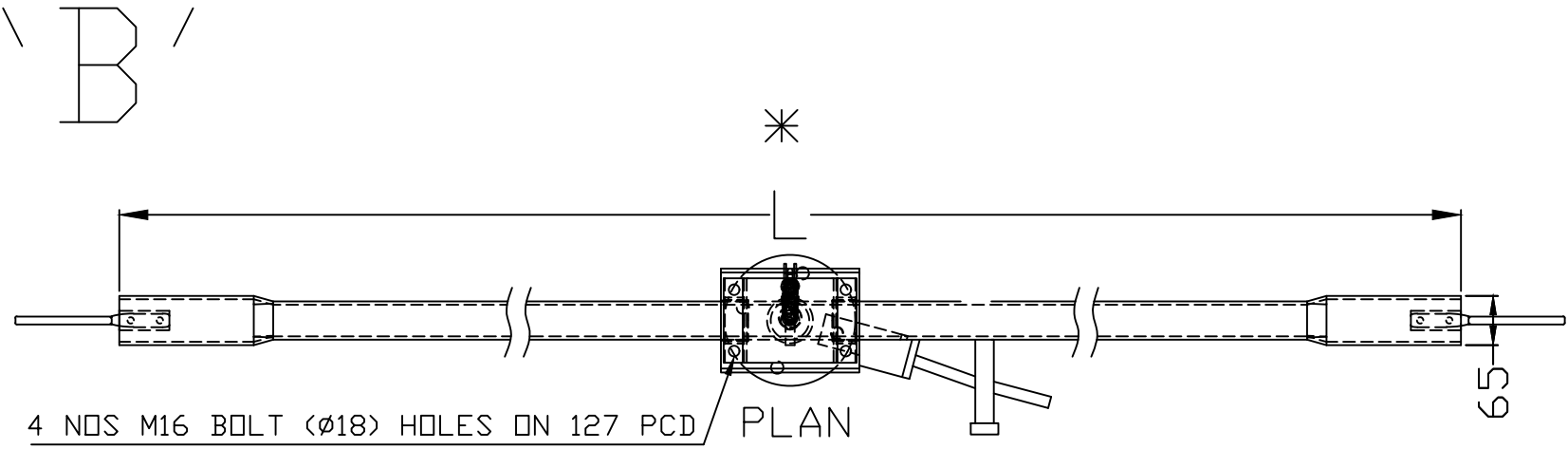

PLAN

4 NOS M16 BOLT (Ø18) HOLES ON 127 PCD

ANNEXURE 1

CURRENT RATING	FIXED CONTACT (A) (CU)				MOVING CONTACT (B) (CU)				TERMINAL PAD	
	SIZE MMxMM	PAIRS NO	AREA SQMM	CURRENT DENSITY A/SQMM	OD MM	ID MM	* (L) LENGTH MM	AREA SQMM	CURRENT DENSITY A/SQMM	SIZE MMxMM
1200	32X4	3	768	1.6000	50	41	3322	643	2.0000	100X12 AL.

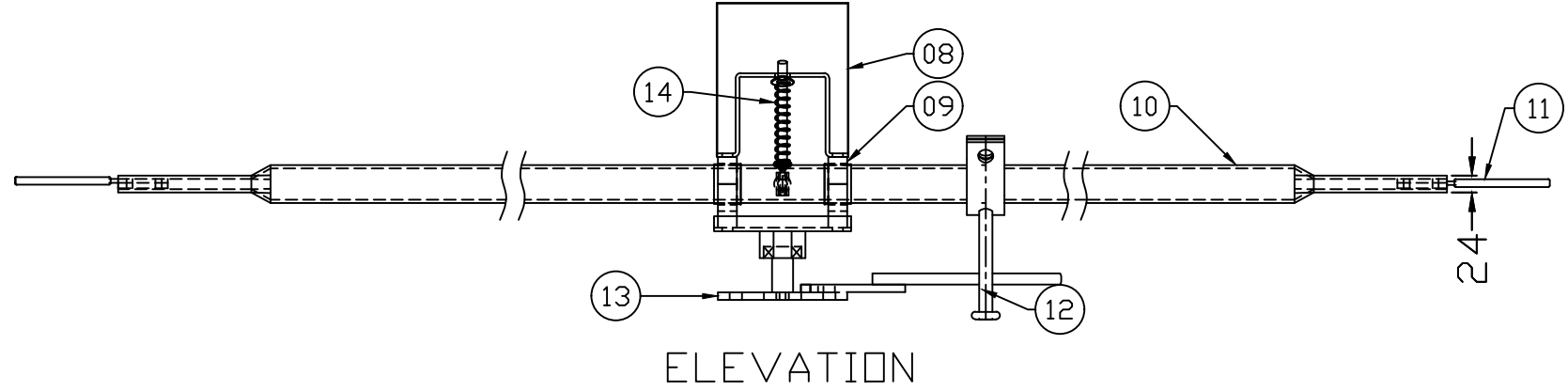

ELEVATION

DETAILS OF MOVING CONTACT

CHIEF ENGINEER/PROJECTS
APTRANSCO/VS/Vijayawada

TRITECH DISCONNECTORS (INDIA) PVT. LTD.
DISCONNECTORS (INDIA) PVT.LTD
MANUFACTURER OF HV/ EHV ISOLATORS

Drawing approval subject to valid vendor registration

REV NO	DATE	DESCRIPTION	SIGN	REV. NO.	SIZE	SHEET	SCALE
				00	A4	1/1	1:1

NAME	SIGN	DATE	TITLE
DRWN SHARAD	SRD	06.04.23	MAIN CONTACTS DETAILS FOR 245KV 1200A ISOLATOR
CHKD P JADHAV	P.J	06.04.23	
APPD P JADHAV	P.J	06.04.23	

DWG. NO : A712MC00AP



This drawing is the property of TRITECH DISCONNECTORS (INDIA) PVT. LTD. and must not be passed on to any person or body not authorised by us to receive it nor be copied or otherwise made use either in full or in part by such person or body without our prior permission in writing.

NOTE:-1. Drawings approval subject to valid type test reports, to be checked during acceptance tests.
2. For EPC contractors only.

SR.	PART LIST	RATING	MAKE	QTY.
1	RUBBER GASKET	-	-	-
2	MANUAL OPERATION WINDOW	-	-	-
3	THERMOSTAT	30-85	GIRISH EGO/VELICO DR EQUIVALENT	01 NO
4	DOOR CLIP	-	-	02 NOS
5	LAMP HOLDER	-	STRACO/ANCHOR	01 NO
6	MCB FOR LAMP, HEATER, A/C SUPPLY	6AMP	L&T/SCHNEIDER/C&S	03 NOS
7	MCBs	16AMP	C&S/SCHNEIDER/SIMENS	02 NOS
8	POWER SOCKET <WITH SWITCH>	-	STRACO/ANCHOR DR EQUIVALENT	01 NO
9	OVERLOAD RELAY	1 TO 1.6	SIEMENS, SPRECHER & SJH, AREVA, SCHNEIDER	01 NO
10	OPEN & CLOSE CONTACTORS	220V DC	SIMENS/SPRECHER & SJH/AREVA/ L&T/ABB/C&S/SCHNEIDER	02 NOS
11	SELECTOR SWITCH	6AMP	KAYCEE/ SURAJ/ SELECT/ VAISHNO/SCI	01 NO
12	PUSH BUTTON <EMERGENCY STOP>	6AMP	SUNJOY/ AMAR/ SURAJ/ SCHNEIDER/C&S	01 NO
13	MOTOR REDUCTION GEAR UNIT	-	DOWN MAKE	01 NO
14	FLAP TO BLOCK MANUAL OPERATION	-	-	01 NO
15	AUXILIARY SWITCH	10AMP	MURGAN POWER/ SWTRON/ SHIRKE	01 NO
16	PUSH BUTTON <OPEN, CLOSE, I/L RELEASE>	6AMP	SUNJOY/ AMAR/ SURAJ/ SCHNEIDER/C&S	03 NOS
17	PROVISION FOR PADLOCK	-	-	-
18	HEATER	80 WATTS	VELICO/GIRISH EGO/SADGURU KRIPA DR EQUIVALENT	01 NO
19	TERMINAL BLOCK	VTS-M3/CAT-M3	VINPAR/ ELEMEX/ JAINSON/ CONNECTWELL	-
20	DETACHABLE TYPE CABLE GLAND PLATE	-	-	01 NO
21	CAM	-	-	02 NOS
22	LIMIT SWITCH	10AMP	BRISK/ HONEYWELL/ ESSEN/ SCHNEIDER/ ELMEX/ IDEAL/ BRITKO	02 NOS
23	SOLENOID COIL	220V DC	ASABA /NASA	01 NO
24	FUSE LINK NEUTRAL	-	L&T/SIEMENS/SCHNEIDER/NSH	01 NO
25	SINGLE PHASE PREVENTOR	415V 50HZ	AJWIN/ELLICO/NINILEC	01 NO

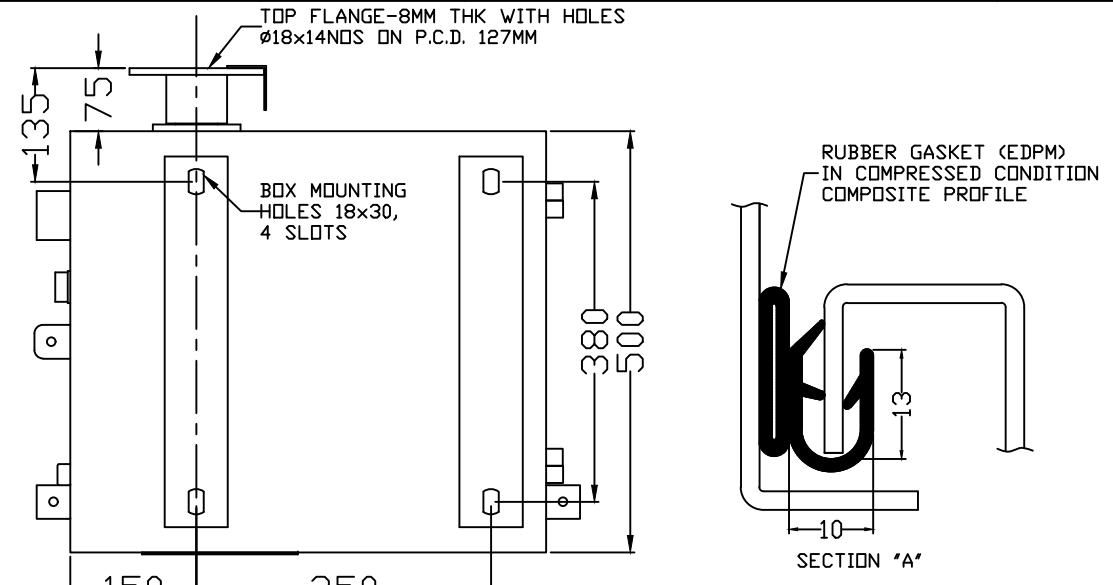
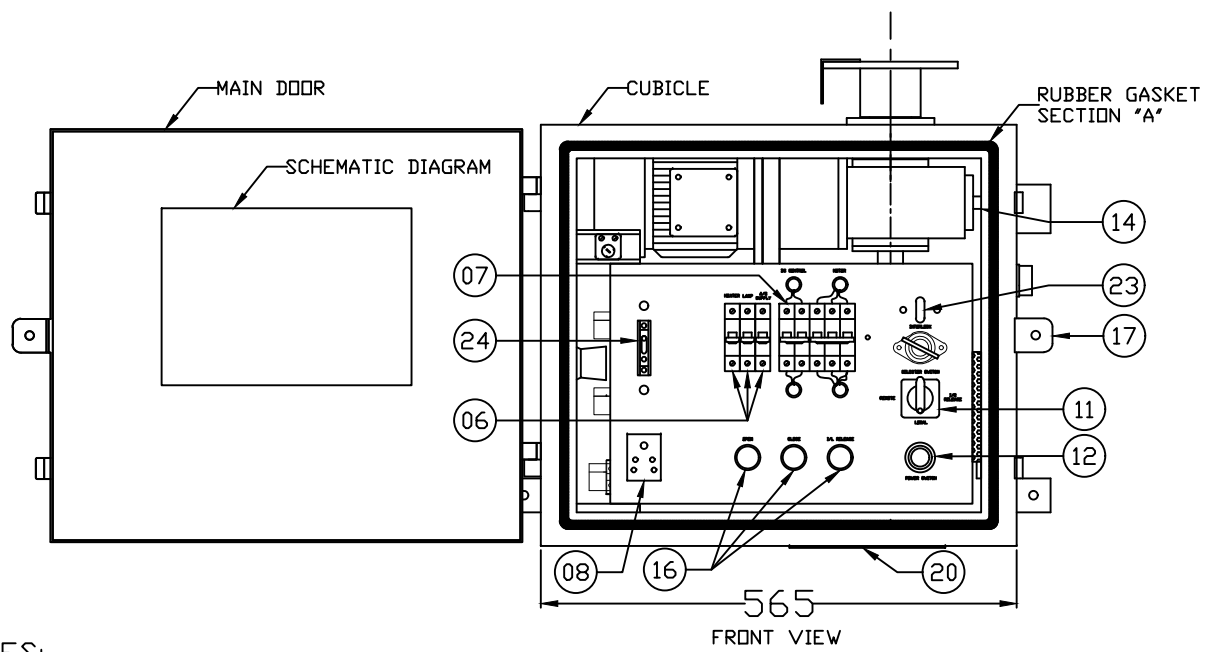
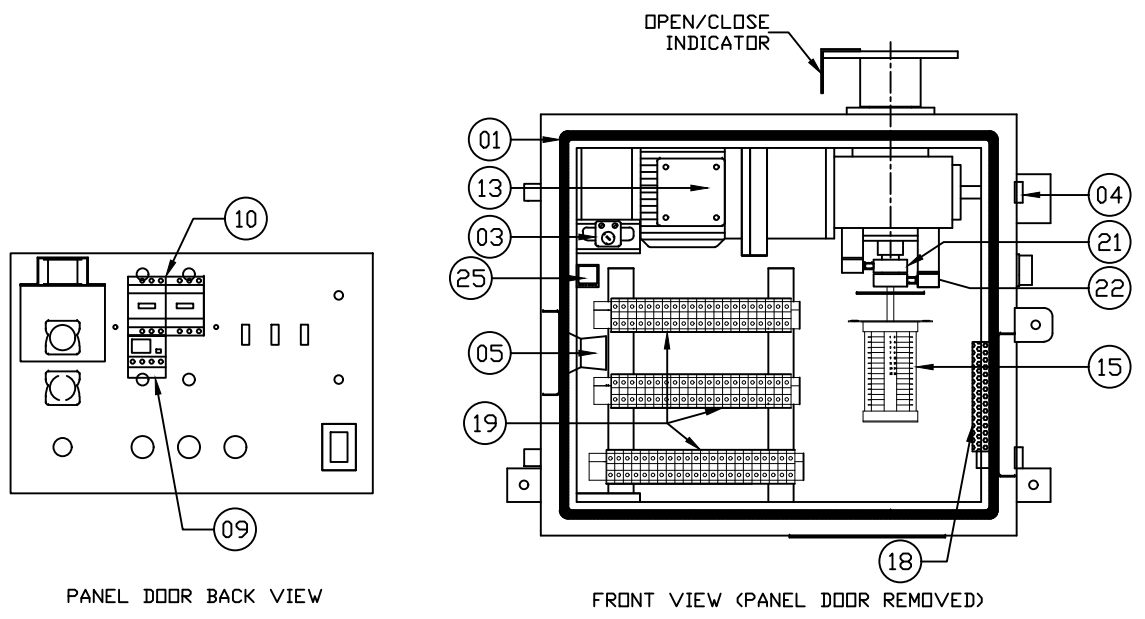

- NOTES:
- ALL DIMENSIONS ARE IN MM.
 - DEGREE OF PROTECTION IP-55.
 - POWDER COATING SHADE OF BOX= LIGHT GRAY (LG 631) THK- 80 MICRONS
 - MANUFACTURING TOLERANCES: ±5%
 - TERMINAL SHALL BE STUD TYPE SUITABLE FOR RING TYPE LUG PROVIDED
 - 20% SPARE TERMINALS PROVIDED FOR CUSTOMER USE.
 - WIRING WILL BE DONE WITH 1100 V. GRADE WITH 2.5 SQ.MM CU. STRANDED P.V.C. INSULATED CONDUCTOR
 - MATERIAL- 3MM THK ALUMINIUM

CHIEF ENGINEER/PROJECTS
APTRANSCO/VS/Vijayawada

TRITECH DISCONNECTORS (INDIA) PVT. LTD.
DISCONNECTORS (INDIA) PVT.LTD
MANUFACTURER OF HV/ EHV ISOLATORS

REV NO	DATE	DESCRIPTION	SIGN	NAME	SIGN	DATE	TITLE
				DRWN	SHARAD	SRD	29.03.22
				CHKD	P JADHAV	P.J	29.03.22
				APPD	P JADHAV	P.J	29.03.22
DWG. NO : XMT10A20AP							G.A. DRAWING OF MOTOR OPERATING MECHANISM BOX
				REV. NO.	SIZE	SHEET	SCALE
				00	A4	1/1	1:1

This drawing is the property of TRITECH DISCONNECTORS (INDIA) PVT. LTD. and must not be passed on to any person or body not authorised by us to receive it nor be copied or otherwise made use either in full or in part by such person or body without our prior permission in writing.

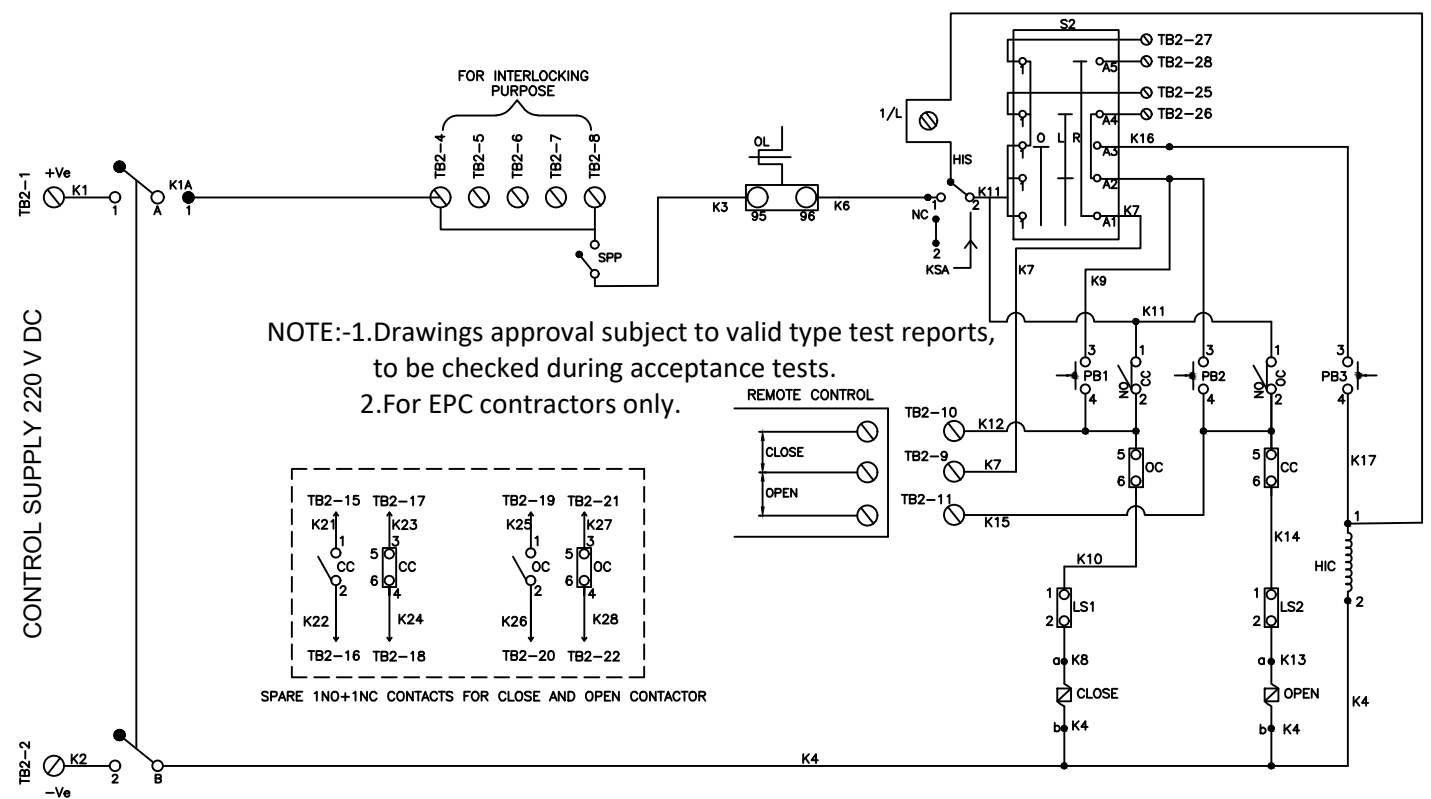

D.C. CIRCUIT

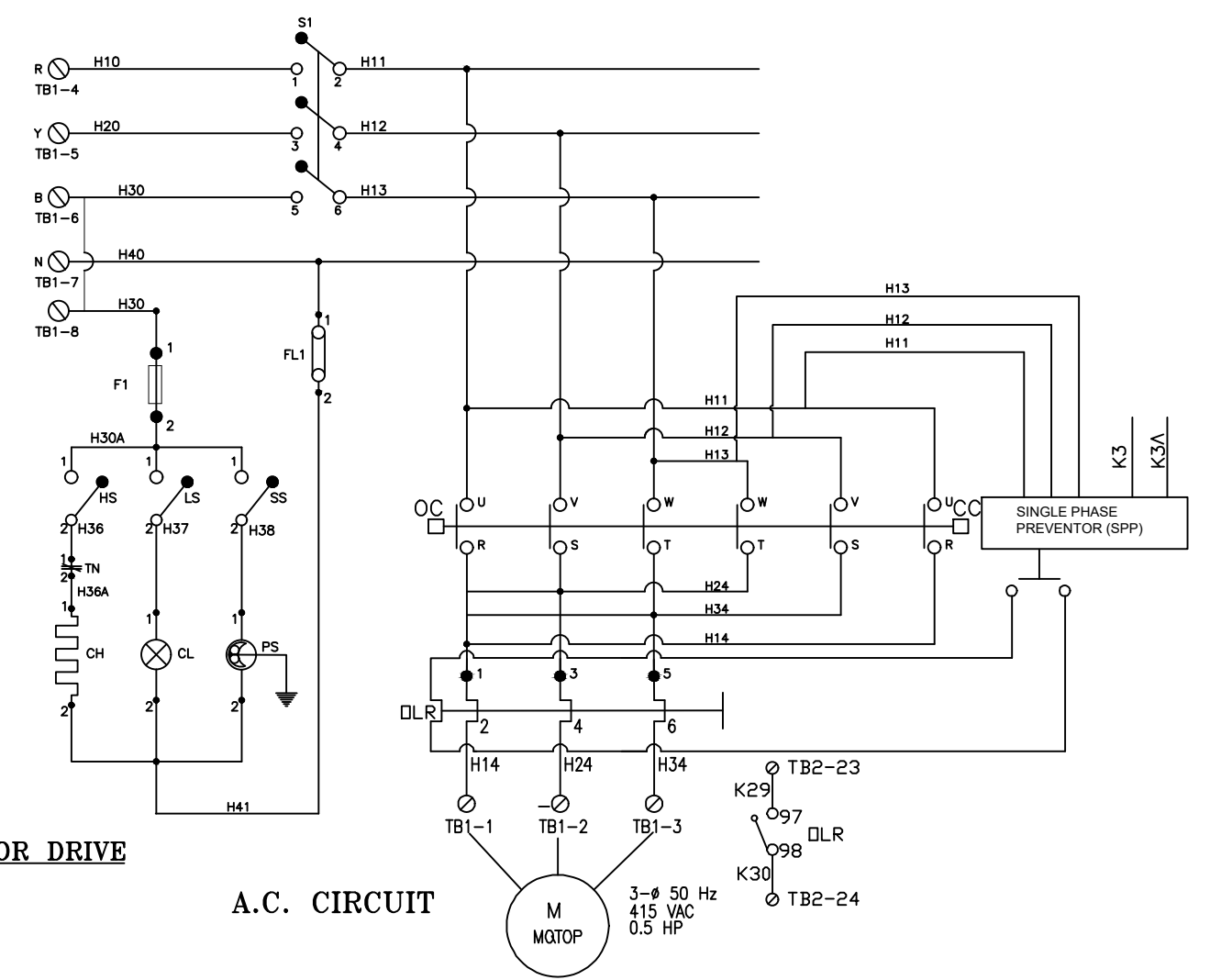

A.C. CIRCUIT

SCHEMATIC DIAGRAM FOR MOTOR DRIVE

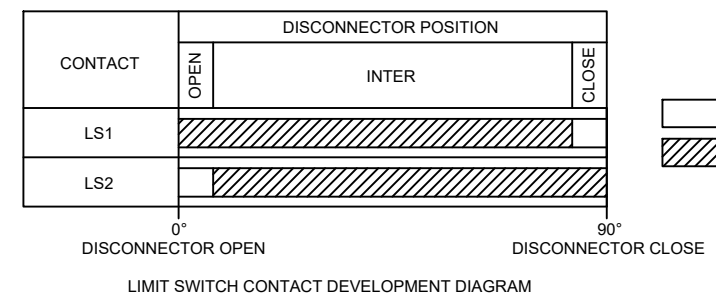
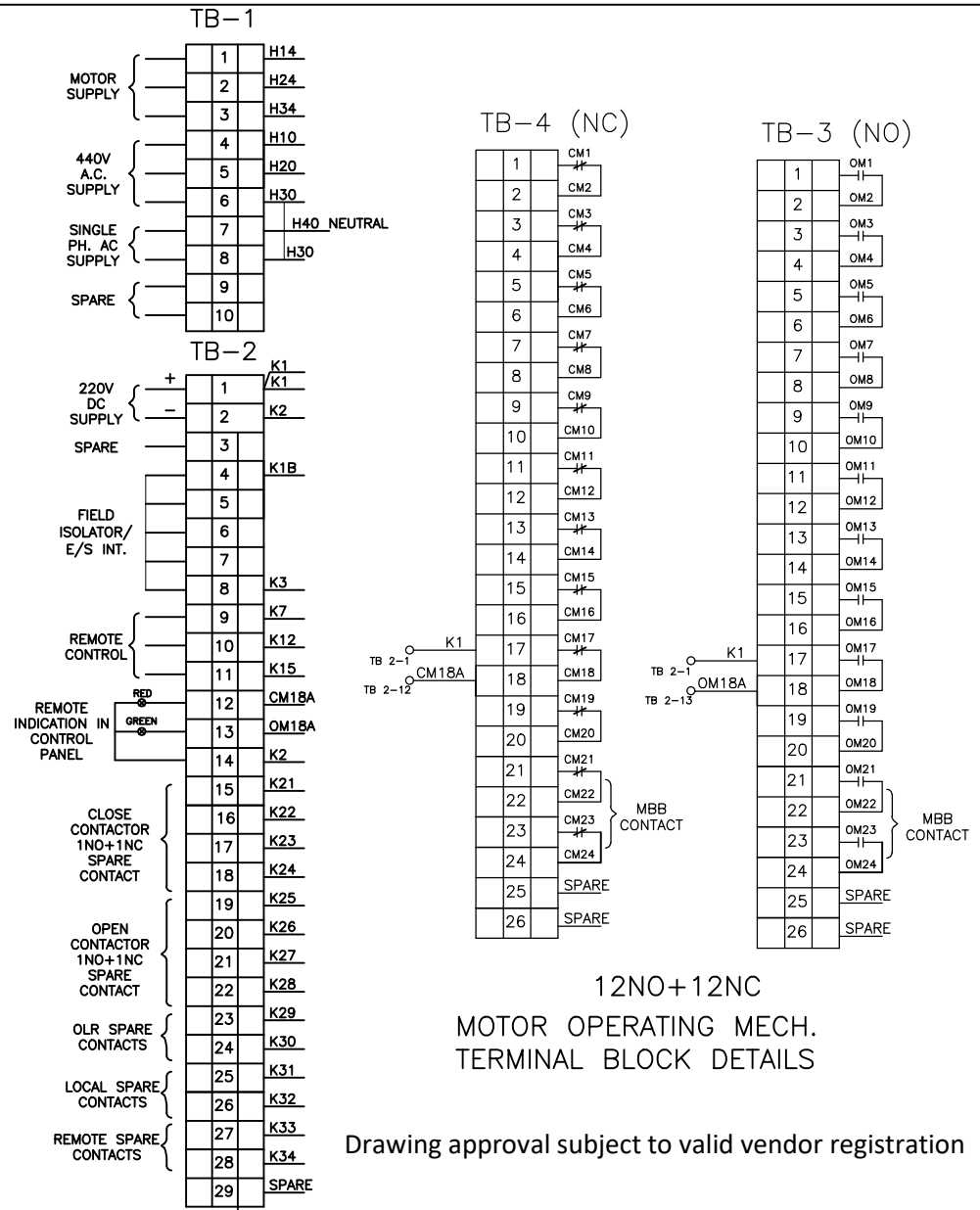

- MANUAL OPERATION INSTRUCTION:**
- BY PRESSING THE PUSH BUTTON (PBH) REMOVE THE CASTLE KEY.
 - INSERT THE KEY IN MANUAL HANDLE LOCK. ROTATE TO REMOVE FLAP.
 - INSERT THE OPERATING HANDLE AND ROTATE IN CLOCK/ANTICLOCK WISE DIRECTION FOR TO OPEN/CLOSE THE ISOLATOR.
 - TERMINALS ARE STUD TYPE.
- NOTE:**
- ALL DIMENSIONS ARE IN MM.
 - BOX POWDER COATED AS PER IS:5
 - THICKNESS OF POWDER COATING (MINIMUM)=80 MICRON
 - POWDER COATING SHADE OF BOX= LIGHT GRAY STRUCTURE (LG 631)
 - REMOVABLE CABLE GLAND PLATE
 - MANUFACTURING TOLERANCES: ±5%
 - DEGREE OF PROTECTION : IP55

CHIEF ENGINEER/PROJECTS
APTRANSCO/Vs/Vijayawada

TRITECH DISCONNECTORS (INDIA) PVT. LTD.
DISCONNECTORS (INDIA) PVT.LTD
MANUFACTURER OF HV/ EHV ISOLATORS

REV NO	DATE	DESCRIPTION	SIGN	DRWN	NAME	SIGN	DATE	TITLE
				SHARAD	SRD	06.04.23		SCHEMATIC DIAGRAM FOR MOTORIZED OPERATING BOX
				P JADHAV	P.J	06.04.23		
				P JADHAV	P.J	06.04.23		
DWG. NO : BMT08A20AP				REV. NO.	SIZE	SHEET	SCALE	
				00	A4	1/1	1:1	

This drawing is the property of TRITECH DISCONNECTORS (INDIA) PVT. LTD. and must not be passed on to any person or body not authorised by us to receive it nor be copied or otherwise made use either in full or in part by such person or body without our prior permission in writing.

NOTE:-1. Drawings approval subject to valid type test reports, to be checked during acceptance tests.
2. For EPC contractors only.

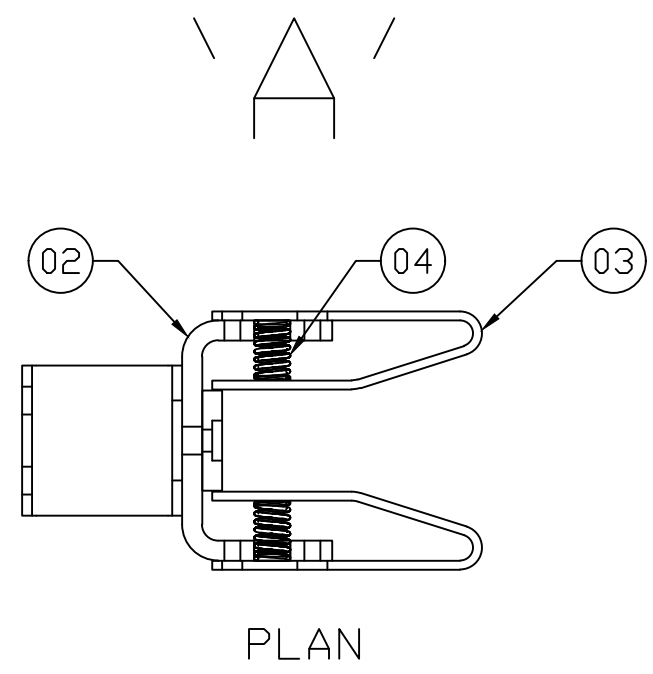

PLAN

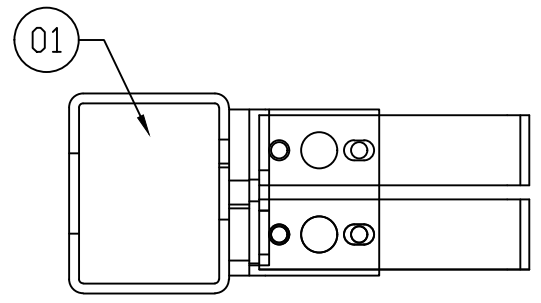

ELEVATION

DETAILS OF EARTH FIXED CONTACT

CHIEF ENGINEER/PROJECTS
APTRANSCO/VS/Vijayawada

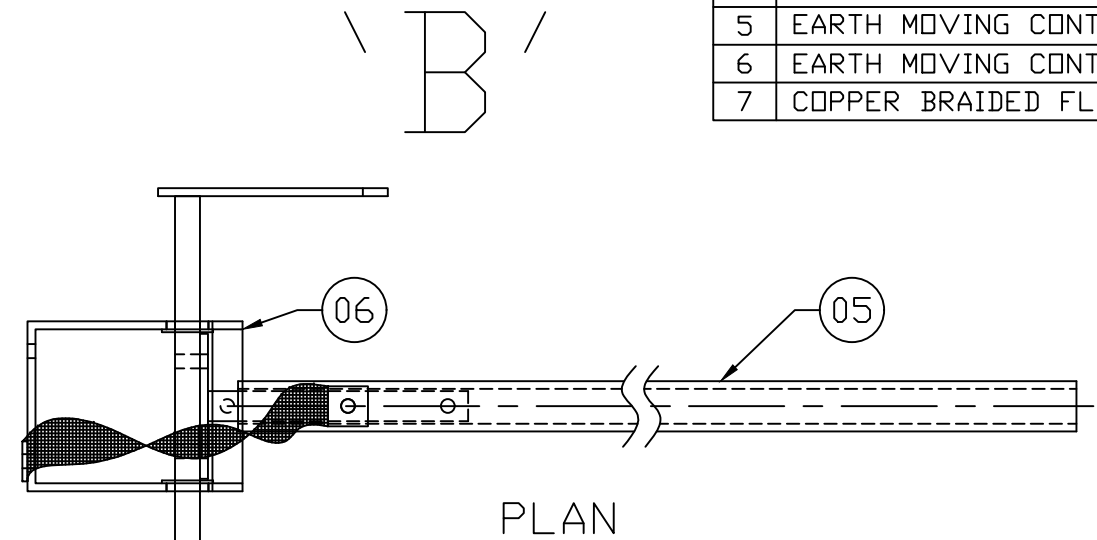

PLAN

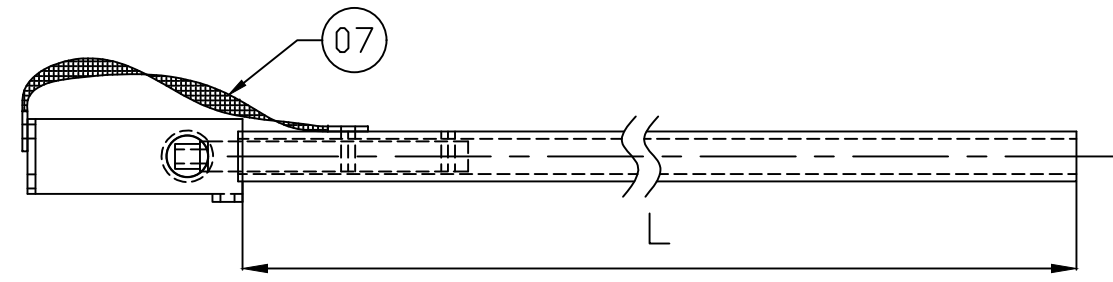

ELEVATION

DETAILS OF EARTH MOVING CONTACT

1. Minimum 300mm plinth shall be maintained for CT/PT/CVT/ Isolators/IVT in the substation during foundation works to ensure safe live to ground clearance as per IE rules.
2. Since the supply of terminal connectors is not in the scope of manufacturers as mentioned in the drawings. The EPC contractors shall be instructed to supply the same in line with CT/PT/CVT/Isolator /IVTs requirement and capability.

SR.	PART LIST	MATERIAL	QTY/ISO
1	EARTH FC SUPPORT BRACKET	MS HDG	6 NOS
2	EARTH FC C BRACKET	AL	6 NOS
3	EARTH FC FINGER 32X4 (2 PAIR)	CU	6 NOS
4	SPRINGS (SS)	SS	24 NOS
5	EARTH MOVING CONTACT (ØD 38, ID 30)	CU	6 NOS
6	EARTH MOVING CONTACT FIXING BRACKET	MS HDG	6 NOS
7	COPPER BRAIDED FLEXIBLE (400 SQ.MM)	CU	6 NOS

NOTE:
1. ALL DIMENSIONS ARE IN MM.
2. ALL FERROUS PARTS ARE HOT DIP GALVANIZED.(87 MICRONS)
3. ALL HDE COPPER CONTACT POINTS ARE SILVER PLATED.(15 MICRONS)
4. TOLERANCE AS PER G.A. DRAWING.
5. FOR CONTACT DETAILS FIX CONTACT 'A' & MOVING CONTACT 'B' DETAILS REFER TABLE ANNEXURE 1

FIXED CONTACT (A) (CU)			MOVING CONTACT (B) (CU)			
SIZE MMxMM	PAIRS NO	AREA SQMM	ØD MM	ID MM	* (L) LENGTH MM	AREA SQMM
32X4	2	512	38	30	2550	427

Nom. cross-section mm ²	Max. permitted current rating approx. A*	Nom. cross-section mm ²	Max. permitted current rating approx. A*
0.10	5	25	150
0.14	6	35	195
0.20	7	50	250
0.25	9	70	300
0.35	10	95	360
0.50	12.5	120	420
0.75	15	150	480
1	18	185	570
1.50	21	240	670
2.50	30	300	780
4	40	400	950
5.25	44	500	1100
6	55	625	1300
8	70	800	1500
10	85	1000	1800
16	120		

* Measured at 35 °C room temperature and max. permitted conductor temperature of 70 °C.

TRITECH DISCONNECTORS (INDIA) PVT. LTD.
DISCONNECTORS (INDIA) PVT.LTD
MANUFACTURER OF HV/ EHV ISOLATORS

REV NO	DATE	DESCRIPTION	SIGN	NAME	SIGN	DATE	TITLE
				DRWN	SHARAD	SRD	06.04.23
				CHKD	P JADHAV	P.J	06.04.23
				APPD	P JADHAV	P.J	06.04.23

DWG. NO : A720CE002AP
 REV. NO. 00
 SIZE A4
 SHEET 1/1
 SCALE 1:1

This drawing is the property of Trittech Disconnectors (INDIA) PVT. LTD. and must not be passed on to any person or body not authorised by us to receive it nor be copied or otherwise made use either in full or in part by such person or body without our prior permission in writing.

NOTE:-1. Drawings approval subject to valid type test reports, to be checked during acceptance tests.
2. For EPC contractors only.

SR.	PART LIST
1	COUNTER WEIGHT -20KG
2	COUNTER WEIGHT SUPPORT ROD-25X25 MS
3	INTERLOCK BRACKET SUPPORT ROD-25X25 MS
4	INTERLOCK BRACKET-8 MM THK (MS)
5	LEVER (40X8MM THK)
6	STOPPER PLATE- 10MM THK
7	BRASS BUSH
8	DOUBLE EARTH INTERLOCK ASSY- 10MM THK MS

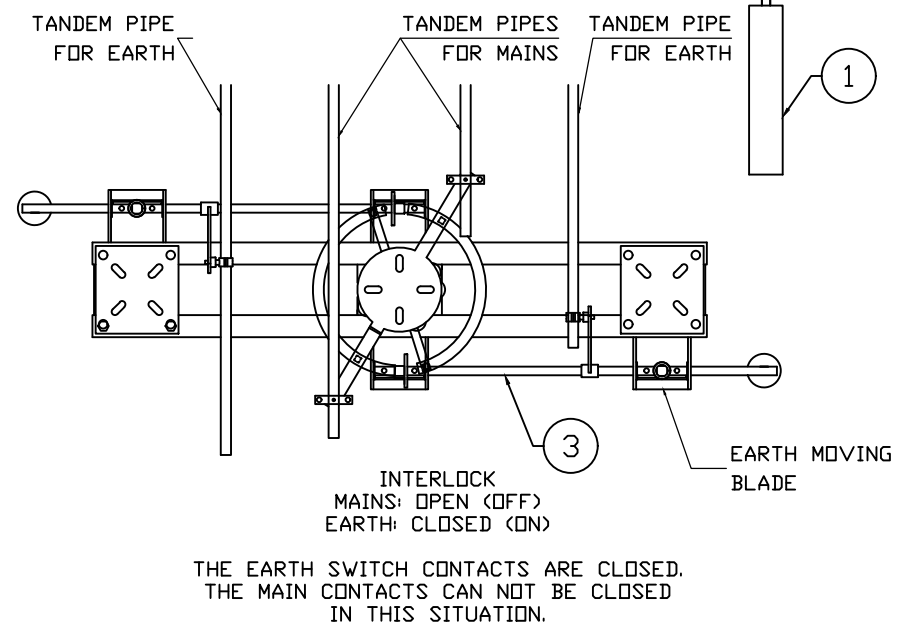
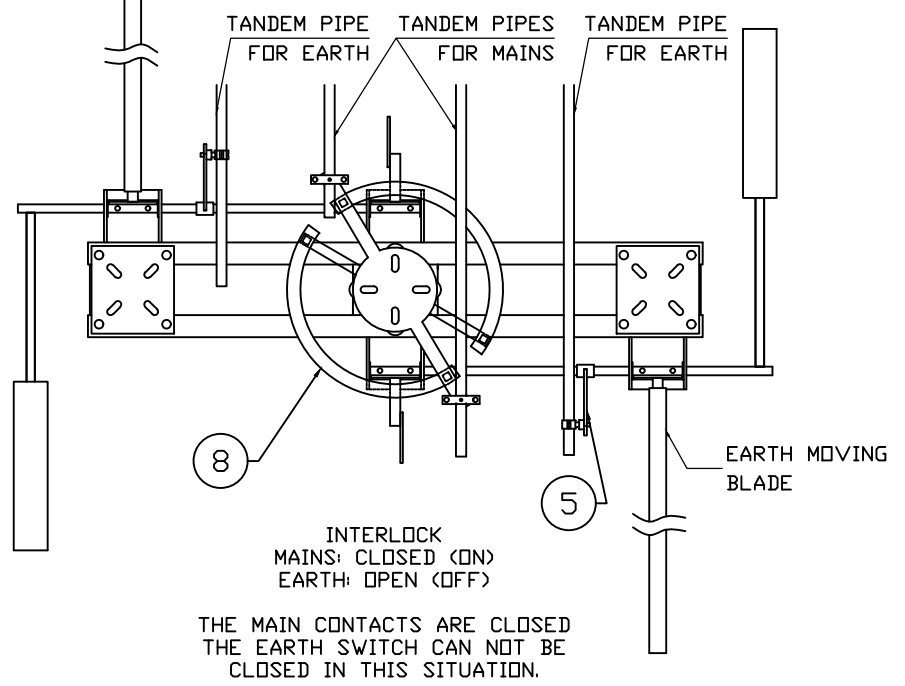
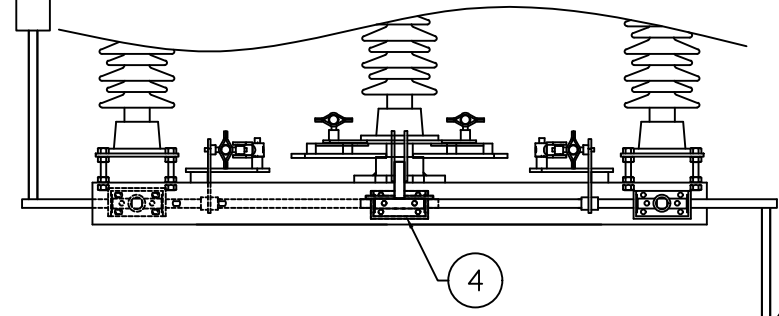
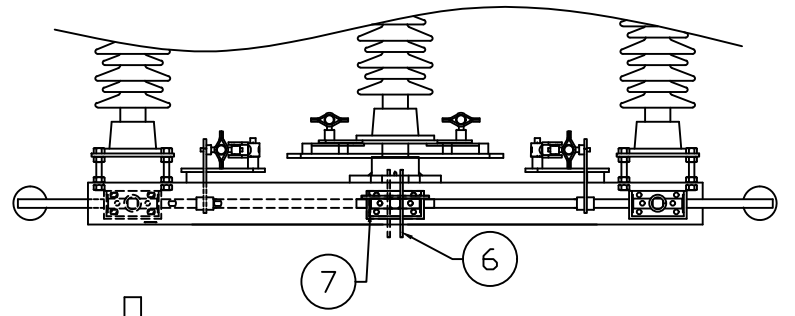

CHIEF ENGINEER/PROJECTS
APTRANSCO/VS/Vijayawada

Drawing approval subject to valid vendor registration



IMAGE FOR MORE CLARITY ONLY



IMAGE FOR MORE CLARITY ONLY



TRITECH DISCONNECTORS (INDIA) PVT. LTD.

REV NO	DATE	DESCRIPTION	SIGN	NAME	SIGN	DATE	TITLE
-				GANESH	GMN	27.06.21	G.A. DRAWING OF INTERLOCK FOR 220KV ISOLATOR
				P JADHAV	PJ	27.06.21	
				P JADHAV	PJ	27.06.21	
DWG. NO : A700IL01				SIZE	SHEET	SCALE	
				A4	1 OF 1	NTS	

This drawing is the property of TRITECH DISCONNECTORS (INDIA) PVT. LTD. and must not be passed on to any person or body not authorised by us to receive it nor be copied or otherwise made use either in full or in part by such person or body without our prior permission in writing.

NOTE:-1. Drawings approval subject to valid type test reports, to be checked during acceptance tests.
2. For EPC contractors only.

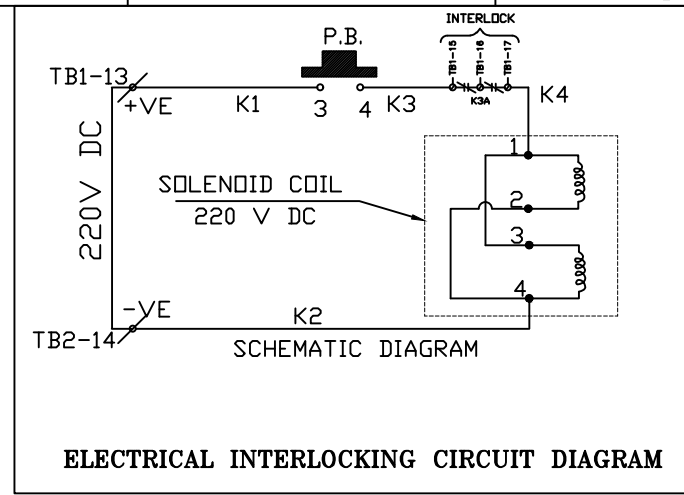
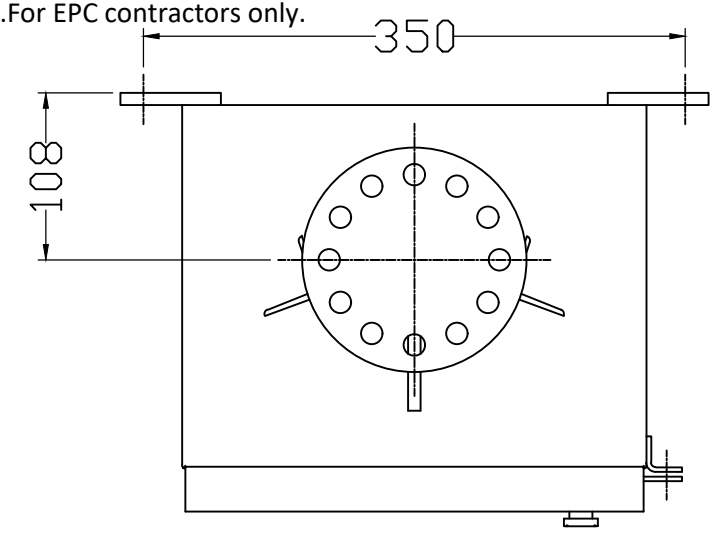

MAKE OF OPERATING BOX - TRITECH DISCON.	
SR.	DESCRIPTION
1	TOP FLANGE-8MM THK. MS
2	ON-OFF STOPPER
3	BOX (AL-3 MM THK.)
4	DOOR WITH GASKET NEOPRENE 3MM THK.
5	AUX SWITCH (6NO + 6NC)
6	PROVISION FOR PADLOCK (WITHOUT LOCK)
7	TERMINAL BLOCK 2.5SqMM STUD TYPE
8	EARTHING TERMINAL (BRACKET TYPE)
9	REMOVABLE GLAND PLATE
10	SOLENOID COIL 220V DC
11	PUSH BUTTON
12	REDUCTION GEARBOX

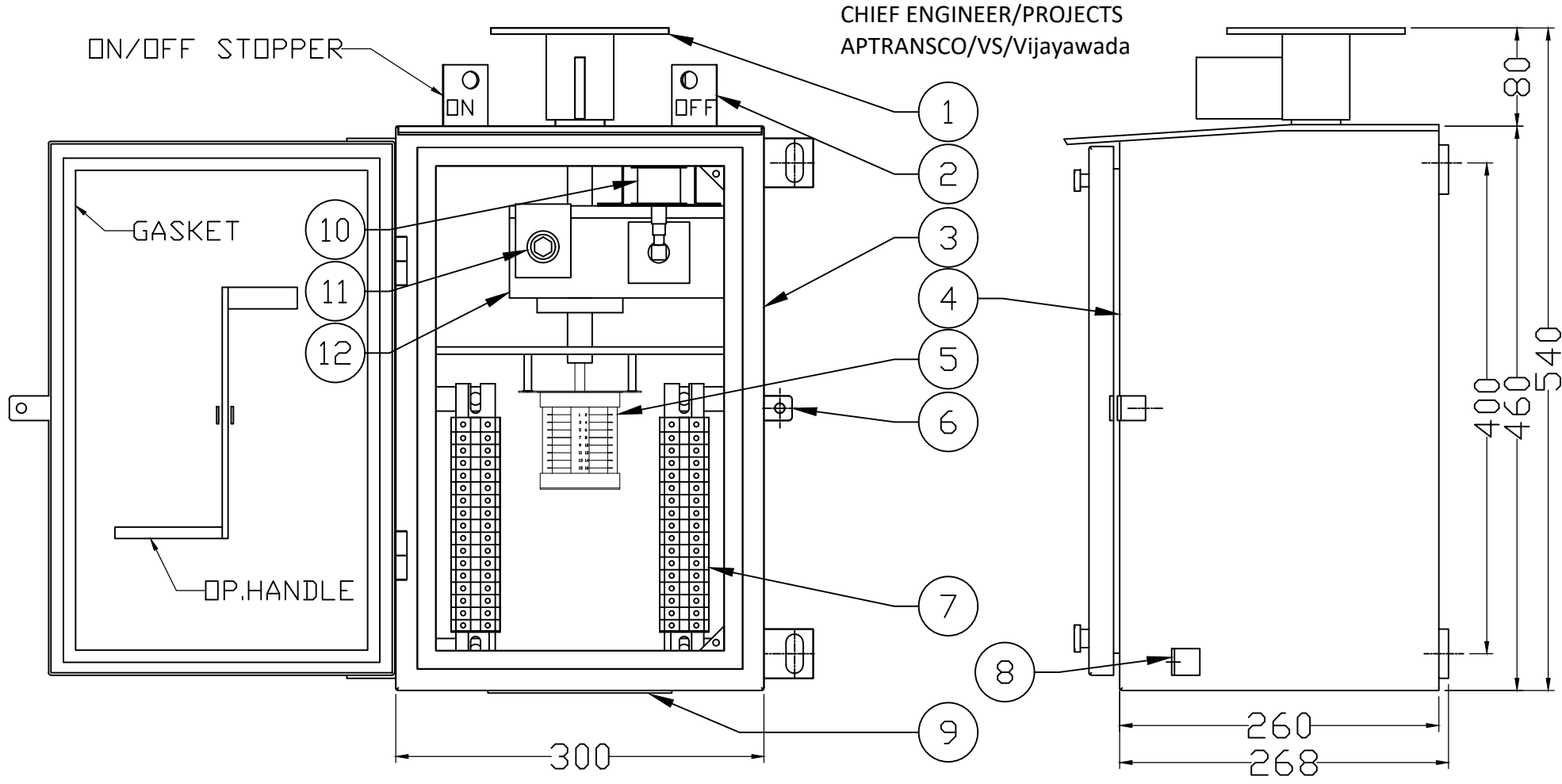

CHIEF ENGINEER/PROJECTS
APTRANSCO/VS/Vijayawada

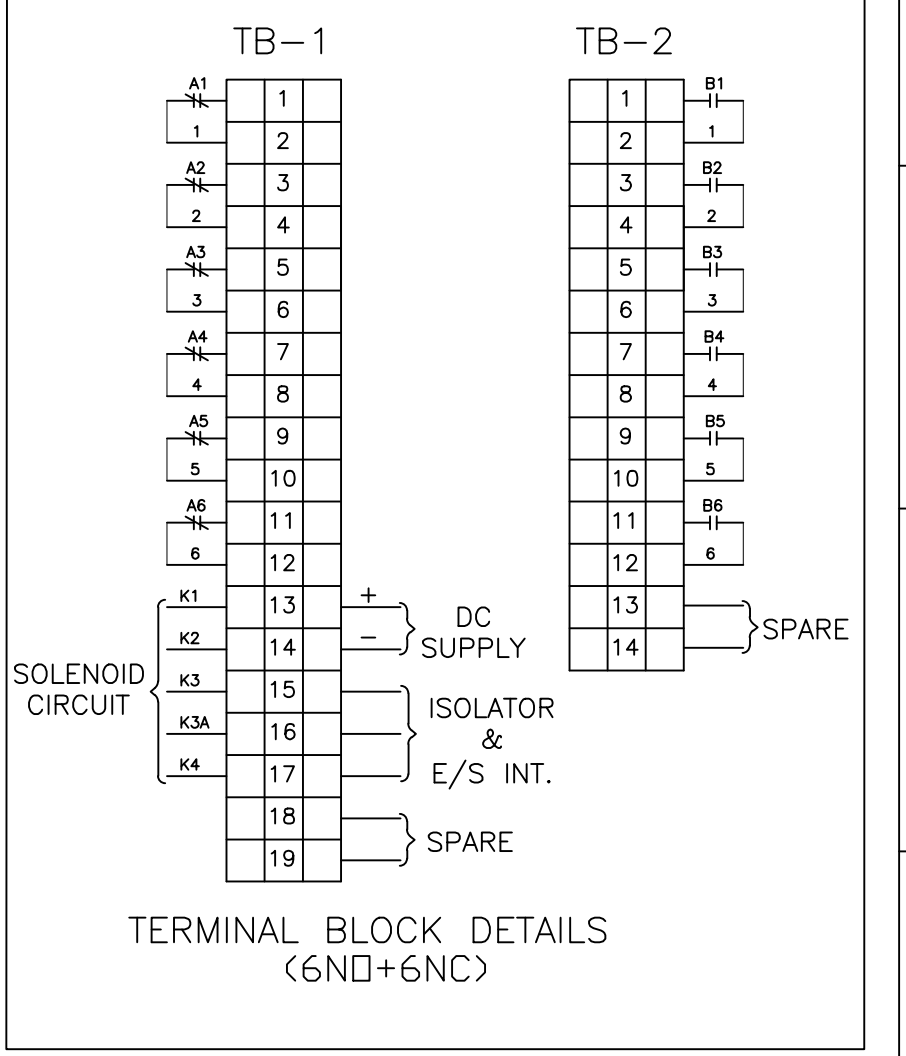

- NOTES:**
- ALL DIMENSIONS ARE IN MM.
 - DEGREE OF PROTECTION IP-55.
 - POWDER COATING SHADE OF BOX= LIGHT GRAY (LG 631) THK- 80 MICRONS
 - MANUFACTURING TOLERANCES: ±5%
 - TERMINAL SHALL BE STUD TYPE SUITABLE FOR RING TYPE LUG PROVIDED
 - 20% SPARE TERMINALS PROVIDED FOR CUSTOMER USE.
 - WIRING WILL BE DONE WITH 1100 V. GRADE WITH 2.5 SQ.MM CU. STRANDED P.V.C. INSULATED CONDUCTOR
 - MATERIAL- 3MM THK ALUMINIUM

Drawing approval subject to valid vendor registration

TRITECH DISCONNECTORS (INDIA) PVT. LTD.
DISCONNECTORS (INDIA) PVT.LTD
MANUFACTURER OF HV/ EHV ISOLATORS

REV NO	DATE	DESCRIPTION	SIGN	REV. NO.	SIZE	SHEET	SCALE
				00	A4	1/1	1:1

NAME	SIGN	DATE	TITLE
DRWN SHARAD SRD		06.04.23	G.A. DRAWING OF REDUCTION GEAR MANUAL OPERATING BOX FOR EARTH SW
CHKD P JADHAV P.J		06.04.23	
APPD P JADHAV P.J		06.04.23	

DWG. NO : XRD08RG1





**TRANSMISSION CORPORATION OF ANDHRA PRADESH LTD .
GUARANTEED TECHNICAL PARTICULARS
GTPS FOR 245KV,1200 AMPS WITH EARTH ISOLATOR.**

Sr. No.	Description	Particulars
1)	Type/Installation	DBCR, OUTDOOR TYPE
2)	Manufacturer's Name and Country of Manufacture	TRITECH DISCONNECTORS (INDIA) PVT LTD, INDIA
3)	Standards according to which the isolators are manufactured	IS 9921, IEC129
4)	Maximum design voltage at which the isolator can operate (kV)	245 KV
5)	Frequency (Hz)	50 HZ
6)	Rated Voltage (kV)	220 KV
7)	Maximum current that can be safely interrupted by the isolator	
a)	Inductive (A & % PF)	0.7 A@0.15 PF
b)	Capacitive (A & % PF)	0.7A@0.15PF
8)	Continuous current rating Nominal (Amps) Under site conditions (Amps)	1200 AMPS
9)	Rated short time current	MAIN & EARTH
a)	For 3 seconds (kA rms)	40 KA RMS
b)	For 1 second (kA rms)	-
c)	Rated peak short time current (kVp)	100 KAP
10)	Current density at the minimum cross-section of	1200
a)	Moving blade (Amps/Sq.mm)	2.0
b)	Terminal pad	AL 1.0
c)	Contacts	1.6
d)	Terminal Connector	1
11)	Maximum Temp. rise of current carrying parts when carrying rated current continuously (deg.c)	WITHIN LIMITS OF IS/IEC
12)	Derating factor for specified site conditions	UNITY
13)	Insulation Levels	
a)	Impulse withstand voltage (kV peak) Phase to Earth & Isolating Distance	1050 KVP/1200 KVP
b)	Switching surge withstand voltage (kV peak) Phase to Earth & Isolating Distance	NOT APPLICABLE
c)	Power Frequency withstand voltage (kV rms) Phase to Earth & Across isolating Distance	460/530 KV RMS FOR 1MINUTE
14)	Minimum clearance in air:	
a)	Between poles (mm)	4000MM FOR PHASE SPACING OF 4500 MM.

b)	Between live parts and earth (mm)	2300MM	
c)	Between live parts when switch is open:		
	i) On the same pole (mm)	3000MM FOR POLE SPACING OF 3200MM.	
	ii) Between adjacent poles (mm)	4000MM	
15)	Rated mechanical terminal load		
	a) Load along the terminal connector side (kg.)	800N	
	b) Load across the terminal connector side (kg.)	270N	
16)	Torque required to operate the switch in Kgm (Not specified)	MAIN-45KGM,EARTH-45 KGM	
17)	Contact Zone		
a)	Horizontal deflection (mm)	NOT APPLICABLE FOR DOUBLE BREAK ISO.	
b)	Vertical deflection (mm)	-----D0-----	
c)	Total amplitude of longitudinal movement w.r.t. conductor supporting fixed contact (mm)	-----DO-----	
18)	Design and Construction		
a)	No. of insulators per pole	THREE STACKS/POLE	
b)	No. of breaks per pole	MAIN-2,ES-SINGLE	
c)	Type of closing /Opening mechanism (Horizontal/Vertical break straight etc.)	MAIN-HORIZONTAL,EARTH SW-VERTICAL BREAK	
d)	Contacts:	<u>MAINS</u>	<u>E/S</u>
	i) Material and grade	CU	CU
	ii) Cross-sectional area (SQ.mm)	768	512
e)	Moving Blades:	<u>MAINS</u>	<u>E/S</u>
	i) Material and grade	CU	CU
	ii) Cross-sectional area (SQ.mm)	643	427
f)	Contact Support:		
	i) Material and size of channel/block	MS HDG, 4MM	
	ii) Material and size of plate	MS HDG., 6MM	
g)	Rain hood - Material grade and size	MS HDG , 5MM	
h)	Turn and twist mechanism		
	i) Material and size of clamps	MS HDG, 6MM	
	ii) Material size of springs	SS, 2.6 MM DIA	
	iii) Whether springs are encased	YES	
i)	Nuts and Bolts:		
	i) Size, material and grade in live parts	LESS THAN 3/8" SS, ABOVE 5/8" HDG	
	ii) Size, material and grade in other parts	3/8" ABOVE HDG	
j)	Insulator base plate Material and size of plate below insulators	MS HDG-10MM	
k)	Bearings:		
	i) Material and size of housing	AL ALLOY, SUITABLE FOR 50 DIA SHAFT.	
	ii) No. of bearings, location and size	2, BELOW ROTATING INSULATOR STACK.	
l)	Tandem pipe:		

7406793/2023/EEMRT-ENE51

	i) Size, length, class and no. of pipes	NB-32,CL B,GI PIPE-10M	
	ii) Size of shackle, screw	-	
	iii) No. of bearings/bush and its material and size	BRASS BUSH.	
m)	Type of interlock (Electromagnet)	ELECTRO MECHANICAL.	
n)	Down pipe size, length and class (40NB)	50 NB,CL B,GI PIPE	
o)	Type of universal/swivel joint		
	i) Between bearing and down pipe	UNIVERSAL.	
	ii) Between down pipe and operating mechanism	VERNIER TYPE	
p)	Operating mechanism:	MAIN	EARTH
		MOTORIZED	RED.GEAR
	i) Control cabinet		
	Material and thickness	3MM THK ALUMINIUM	
	Degree of protection	IP 55	
	Type size and No. of cable glands	CONTRACTORS SCOPE	
	Whether removable gland plate provided	YES	
q)	Base:		
	i) Size of steel sections used	150X75X5 MM	
	ii) Overall size	150X75X5X3470 MM	
	iii) Total weight	140 KG /POLE	
r)	Aux switch	12 NO / 12 NC CONTACT FOR MAINS SWITCH 6NO+6NC CONTACTS FOR EARTH SWITCH, 10A,DC breaking with 2A - 1 No.	
s)	Terminal blocks	M3 Stud type TB	
t)	Insulated Wires	1100 V grades, 2.5 Sq.mm PVC For Auxiliary Circuit and 2.5 Sq.mm for Power circuit	

1. Minimum 300mm plinth shall be maintained for CT/PT/CVT/ Isolators/IVT in the substation during foundation works to ensure safe live to ground clearance as per IE rules.
2. Since the supply of terminal connectors is not in the scope of manufacturers as mentioned in the drawings. The EPC contractors shall be instructed to supply the same in line with CT/PT/CVT/Isolator /IVTs requirement and capatibility.

Drawing approval subject to valid vendor registration