

## TRANSMISSION CORPORATION OF ANDHRA PRADESH LTD.

## GUARANTEED TECHNICAL PARTICULARS FOR 245KV 1600A HDB ISOLATOR WITH DOBULE EARTH SWITCH

S.No	DESCRIPTION	GUARANTEED VALUE
1	Type / Installation	: "DBR" Double Break Center post rotating type" / Outdoor installation
2	Manufacturer's Name and Country of Manufacture	: PAVANI POWR SYSYEM PVT LTD. INDIA
3	Standards according to which the isolators are manufactured	: IS: 9921 - Part-I to V / IEC:62271-102
4	Miximum design voltage at which the isolator can operate (kV)	: 245 Drawing approval subject to valid vendor registration
5	Frequency (Hz)	: 50
6	Rated voltage (kV)	: 220
7	Maximum current that can be safely interrupted by the isolator Inductive (A & % PF ) Capacitive (A & % PF)	: Inductive- 0.7 Amps at 0.15 p.f. Capacitive- 0.7 Amps at 0.15 p.f.
8	Continuous current rating Nominal (Amps) under site conditions	: 1600
9	Rated short time current	: MAIN SWITCH / EARTH SWITCH.
	i) For 3 seconds (kA rms)	: 40 / 50KA 3.Sec.
	ii) For 1 second (kA rms)	: Not applicable
	iii) Rated peak short time current (kVp)	: 100 / 125
10	Current density at the minimum cross-section of	: Contact sizes indicated in Annexure - III of specification & as per the property of materials.
	a) Moving blade (Amps/ Sq.mm) Cu. Tube	: 2.0 Amps / Sq.mm for HDE Cu. Tube
	b) Terminal pad : Aluminum Flat	: 1.0 Amp/ Sq.mm for EC grade Alu. Flat
	c) Contacts : Cu.Flat	: 1.6 Amps/Sq.mm for HDE Cu. Flat
	d) Terminal connector : Aluminm Casting	: 1.0 Amps/Sq.mm for Alu. Alloy.
11	Maximum Temp. Rise of current carrying parts when carrying rated current continuously (deg.C)	: Within the specified limits of IS: 9921 - PartII/ IEC-62271-102
12	<b>Insulation Levels</b>	:
	i) Impulse withstand voltage (kV peak) phase to earth across isolating distance:	: 1050/ 1200 kV peak
	ii) Switching surge withstand voltage (kV peak) phase to earth across isolating distance	: Not applicable
	iii) Power frequency withstand voltage (kV rms) Phase to earth isolating distance	: 460/ 530 kV rms
13	<b>Minimum clearance in air</b>	:
	i) Between poles (mm)	: Phase spacing of 4500 mm
	ii) Between live parts and earth (mm)	: 2100 mm (Equal to dry arcing distance of insulators selected)
	iii) Between live parts when switch is open	:
	a) On the same pole (mm)	: 3200
	b) Between adjacent poles (mm)	: 4500

Since the supply of terminanal connectors is not in the scope of manufacturer as mentioned in the drawings. The EPC contractor shall be instructed to supply the same line with CT/PT/CVT/Isolator/IVT /LA /Breaker requirement and campability.

S.No		DESCRIPTION	GUARANTEED VALUE
15		<b>Rated mechanical terminal load</b>	:
i)	Load along the terminal connector side (Kg.)	:	102
ii)	Load across the terminal connector side (Kg.)	:	33.7
16		Torque required to operated the switch in Kg.m	: 40
17		<b>Design and Construction</b>	:
i)	No. of insulators per pole	:	Three <b>CHIEF ENGINEER/PROJECTS</b>
ii)	No. of breaks per pole	:	Two <b>APTRANSCO/VS/VIJAYAWADA</b>
iii)	Type of closing / opening mechanism (Horizontal/Vertical break straight etc.)	:	Horizontal double break
iv)	Contacts	:	
	a) Material and grade	:	Hard drawn electrolytic copper flat, contact area is silver plated (15 Microns)
	b) Cross-sectional area (mm)	:	1017.6 sq.mm for 1600 Amps
v)	<b>Moving blades</b>	:	
	a) Material and grade	:	Hard drawn electrolytic copper flat, contact area is silver plated (15 Microns)
	b) Cross-sectional area (mm)	:	829 sq.mm for 1600 Amps
vi)	<b>Contact support</b>	:	
	a) Material and size of channel/block	:	4 mm thick, MS HDG
	b) Material and size of plate	:	6 mm thick, MS HDG Plate
vii)	Rain hood - Material grade and size	:	1mm GI Sheet
viii)	Turn and twist mechanism	:	
	a) Material and size of clamps	:	50 x 10 mm thick, MS HDG flat.
	b) Maerial size of springs	:	3.0 mm Stainless steel wire
	c) Whether springs are encased	:	Not encased.
ix)	Nuts and Bolts	:	
	a) Size, material and grade in live parts	:	Less than M12: Stainless steel
	b) Size, material and grade in other parts	:	M12 and above: MS HDG.
x)	Insulator base plate material and size of plate below insulators	:	270 x 270 mm X 12mm MS HDG plate
xi)	Bearings	:	
	a) Material and size of housing	:	MS HDG suitable for 40 ID tapper roller/ ball bearing.
	b) No. of bearings, location and size	:	2 Nos . Below centre rotating post insulator.

Since the supply of terminanal connectors is not in the scope of manufacturer as mentioned in the drawings. The EPC contractor shall be instructed to supply the same line with CT/PT/CVT/Isolator/IVT /LA /Breaker requirement and campability.

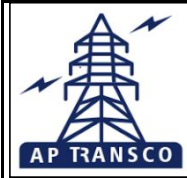

**TRANSMISSION CORPORATION OF ANDHRA PRADESH LTD.**

**GUARANTEED TECHNICAL PARTICULARS FOR 245KV 1600A HDB ISOLATOR WITH DOBULE EARTH SWITCH**

S.No	DESCRIPTION	GUARANTEED VALUE
xii)	Tandem pipe	:
	a) Size, class and No. of pipes	: 32mm NB Class B,GI Pipe for Main switch-2Nos for Earth switch-1No.
	b) Size of shackle, screw	: Suitable for 32mm NB GI Pipe
	c) No. of bearings/bush and its material and size	: Not applicable
xiii)	Type of interlock	: Electrical interlock between isolator and correspondin breaker / Mechanical interlock between M.S & E.S.
xiv)	Down pipe size and class	: 50 NB Class B GI pipe
xv)	Type of universal/swivel joint	:
	a) Between bearing and down pipe	: Universal joint
	b) Between down pipe and operating mechanism	: Vernier flange
xvi)	Operating mechanism	: Motor operated mechanism for main switch and manual operated mechanism with reduction gear for earth switch.
	a) Control cabinet material and thickness	: 3.mm THK Aluminum Sheet
	b) Degree of protection	: IP: 55 as per IS: 2147
	c) Type, size and No. of cable glands	: Double compression type 2Nos. 19 mm (Contractor scope of supply)
	d) Whether removable gland plate provided	: Yes, provided.
	e) Make, type, rating and quantity of motors	: HE/CGL/Remi or Eqvt. 3 Phase, 415 V, 0.5 HP
	f) Auxilliary blocks	: 12 NO + 12 NC Contacts for main switch, 6 NO + 6 NC Contacts for Earth switch, 10 Amps, 2 A DC Breaking with 2A - 1 No.
	g) Terminal blocks	: UBT-4
	i) Insulated wires	: 1100 V grades, 2.5 Sq.mm PVC For Auxilliary Circuit and 2.5 Sq.mm for Power cricuit.
	j) HRC Fuse / MCB	: C&S/Siemns/ABB or Eqvt.
	k) Space Heater	: 1 No. 230 V AC - 80 watts
	l) Interlocks	: with Rotary switch Kaycee or Eqvt.
xvii)	Base:	:
	a) Size of steel section used	: 145x80x5mm Rectangle box profile(M.S.HDG)
	b) Overall sie	: 145 x 80 x 3560 mm
	c) Total weight.	: 95Kgs (Approx.) one pole
18	List of drawings furnished.	: Enclosed.
<p style="text-align: right;">Name of the firm : <b>For Pavani Power Systems Pvt. Ltd.</b></p> <p style="text-align: right;">Signature of Bidder : </p> <p style="text-align: right;">Designation &amp; Seal : <b>( T. SESHAGIRI RAO ) Managing Director</b></p> <p style="text-align: right;">Date : 18-05-2023</p> <p><b>CHIEF ENGINEER/PROJECTS</b> <b>APTRANSCO/VS/VIJAYAWADA</b></p>		

NOTE: 1. Drawings Approval subject to valid type test reports, to be checked during acceptance tests.

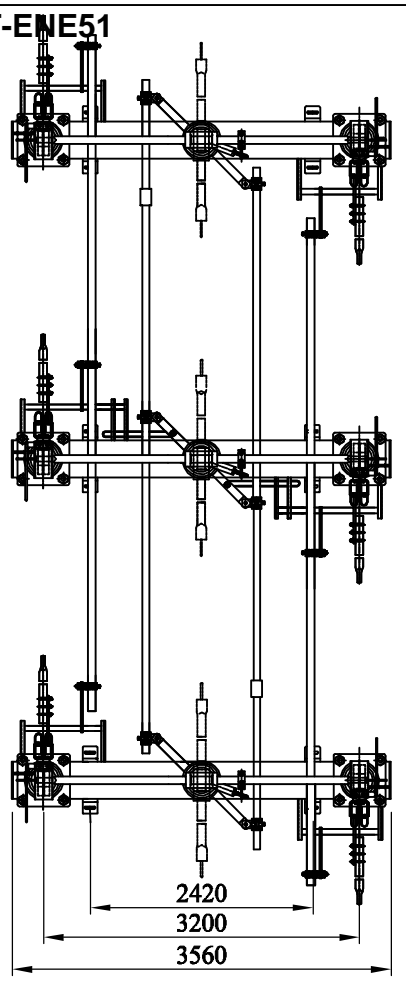
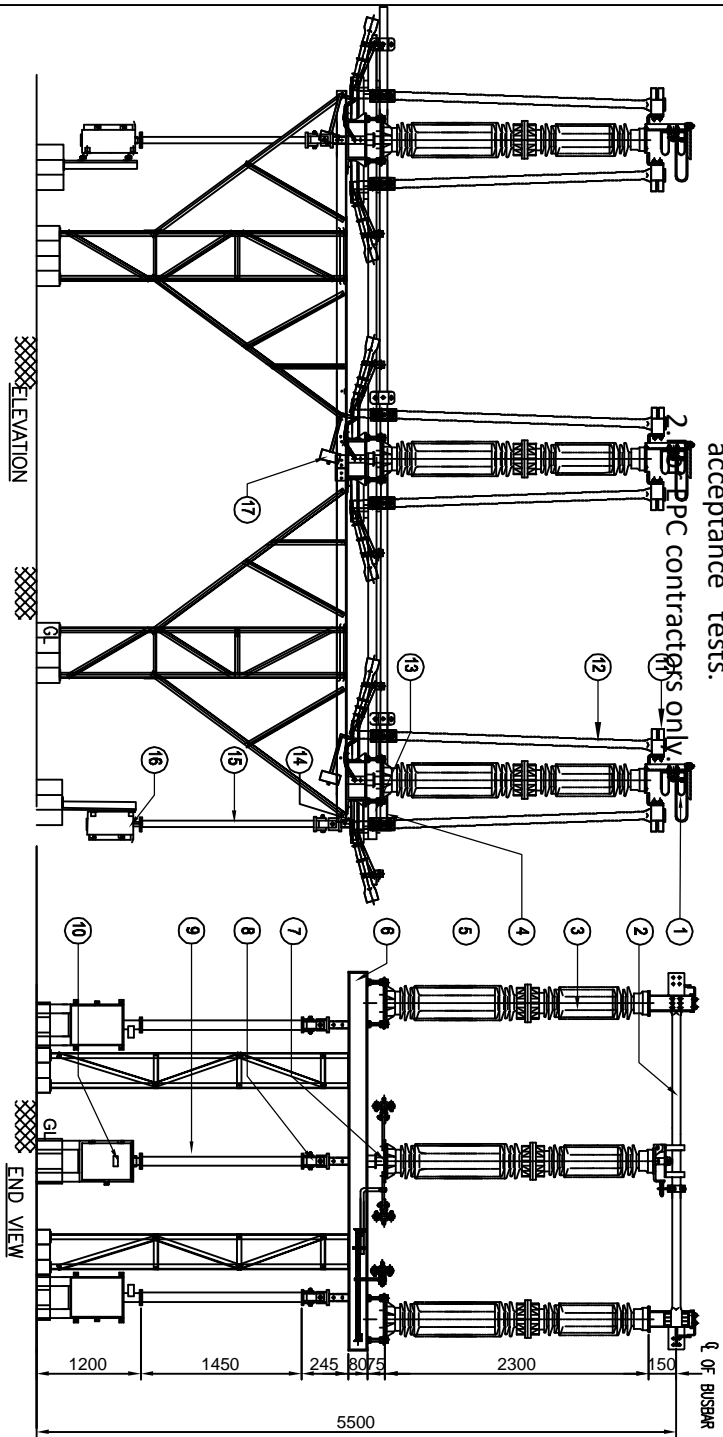

Drawing approval subject to valid vendor registration

CHIEF ENGINEER/PROJECTS  
APTRANSCO/VS/VIJAYAWADA

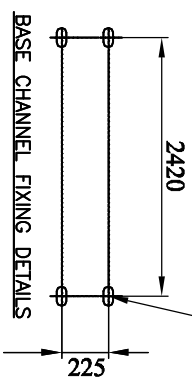
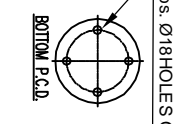

**PART LIST:**

1. FIXED CONTACT ASSEMBLY
2. MOVING CONTACT ASSEMBLY
3. INSULATOR STACK ( COSTUMER SCOPE)
4. TANDEM PIPE FOR ISOLATOR (32NB, CLASS "B" G.I PIPE)
5. ELEVATOR PLATE (270X270X12MM THK M.S HDG)
6. BASE CHANNEL (145 X 80 X 5MM THK. M.S HDG)
7. ROTATING STOOL BASE WITH LEVER ARM & CLAMP (M.S HDG)
8. OPERATING PIPE CONNECTING BUSH ( M.S HDG)
9. DOWN PIPE FOR ISOLATOR (50NB CLASS"B" G.I PIPE)
10. MOTOR OPERATING MECHANISM FOR ISOLATOR
11. E.S FIXED CONTACT ASSEMBLY
12. E.S MOVING CONTACT ASSEMBLY
13. TANDEM PIPE FOR E.S (32NB CLASS "B" G.I PIPE)
14. TOP OPERATING MECHANISM FOR EARTH SWITCH (M.S HDG)
15. DOWN PIPE FOR E.S (50NB CLASS "B" G.I PIPE)
16. MANUAL OPERATING MECHANISM FOR E.S (RG BOX)
17. COUNTER WEIGHT FOR E.S ( Per pole 10Kgs Approx.)

**REFERENCE DRAWINGS:**

1. FOR ISOLATOR CONTACT ASSEMBLY (1600 AMPS)
2. FOR EARTH SWITCH CONTACT ASSEMBLY
3. FOR MOTOR OPERATED MECHANISM FOR MAIN SWITCH
4. FOR MANUAL OPERATED MECHANISM FOR EARTH SWITCH
5. FOR MECHANICAL INTERLOCK BETWEEN ISOLATORS AND EARTH SWITCH.
6. FOR SCHEMATIC DIAGRAM
7. FOR TERMINAL BLOCK DETAILS
8. FOR NAME PLATE DETAILS

**NOTE:**

1. ALL DIMENSIONS ARE IN MILLIMETERS
2. THE INDICATED DIMENSIONS ARE SUBJECT TO THE MANUFACTURING TOLERANCE:  
 UP TO 50mm: -----±3%; 51 TO 100mm: ----- ±2%  
 101 TO 300mm: ----- ± 1%; ABOVE 300mm: -----±0.5%  
 3. SHORT TIME CURRENT RATING 40KA/50KA rms FOR 3 Sec.  
 4. MIN. CREEPAGE DISTANCE 3625 mm(25mm/KV)  
 5. APPLICABLE STANDARD : IEC: 62271-102  
 6. ALL FERROUS PARTS ARE HOT DIP GALVANIZED (85MICRONS)

For Pavani Power Systems Pvt. Ltd.

( T. SESHAGIRI RAO )  
Managing Director

TRANSMISSION CORPORATION OF  
ANDHRA PRADESH LTD



TITLE:		SCALE: 1:1	
245KV, 1600A, TP, HDB, RT, ISOLATOR WITH DOUBLE E.S.		18-05-2023	
( WITH MOTOR OPERATING MECHANISM )		DRAWN	
( WITH MOTOR OPERATING MECHANISM )		CHECKED	
P.V. SESHAGIRI RAO		APPROVED	
P.V. SESHAGIRI RAO		SHEET	
P.V. SESHAGIRI RAO		01 OF 09	
P.V. SESHAGIRI RAO		PPSP-APT-CAD-44-01	



PAVANI POWER SYSTEMS PVT.LTD.  
Plot No. 05/055/4/6, K.K. OVERSEAS SOCIETY,  
IDA, DULAPALLY, QUTHUBULLAPUR MANDAL,  
KOMURU FORT, HYDERABAD - 500100.  
KERALA WALKER DIST. TELANGANA

NOTE: 1. Drawings Approval subject to valid type test reports, to be checked during acceptance tests.  
2. For EPC contractors only.

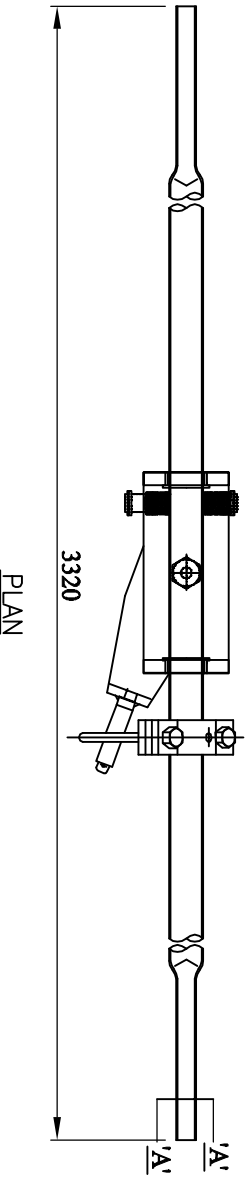
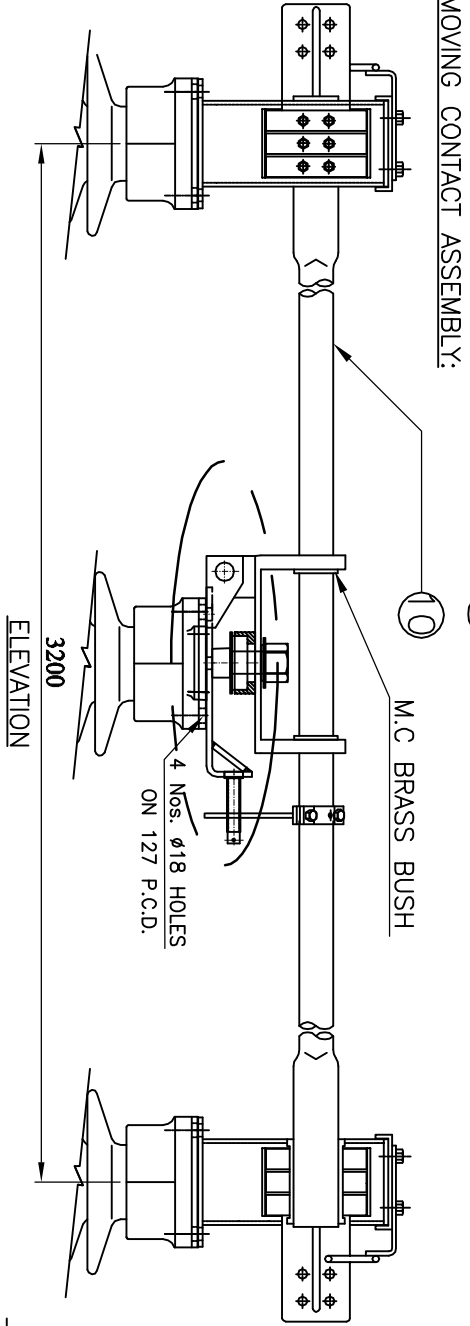
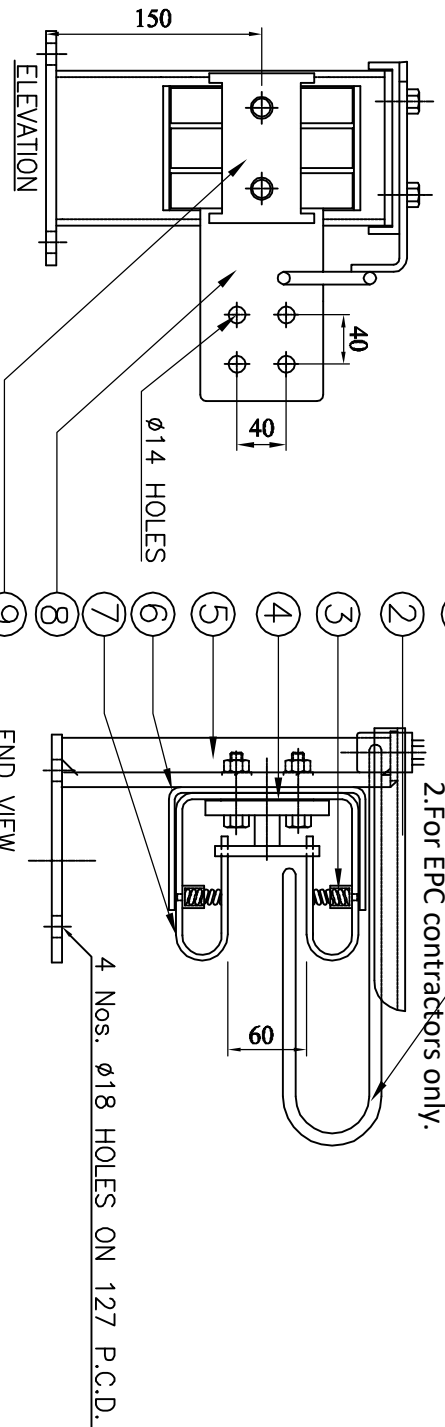

BILL OF MATERIAL PER ONE SET

SL NO.	DESCRIPTION	SIZE IN MM	MATERIAL
1.	ARCING HORNS	Ø10MM ROD	M.S HDG
2.	RAIN HOOD	1MM SHEET	M.S HDG
3.	JAW SPRINGS	Ø2mm WIRE	STAINLESS STEEL
4.	BI-METALLIC SHEET	2mm THK	ALU. + CU.
5.	FIXED CONTACT SUPPORT CHANNEL	115x30x4 mm	M.S HDG
6.	JAW SUPPORT BRACKETS	32 X 5 FLAT	M.S HDG
7.	FIXED CONTACT JAWS ( 3. NOS)	32 X 5.3 FLAT	HDEC
8.	JUMPER PAD	100 X 16 FLAT	ALUMINIUM
9.	FC SPACER	-----	ALUMINIUM
10.	MOVING CONTACT	50-ODX38-ID	HDEC

- NOTE:
1. ALL DIMENSIONS ARE IN MILLIMETER
  2. ALL FERROUS PARTS ARE HOT DIP GALVANIZED (85 MICRONS)
  3. ALL NON FERROUS CONTACT POINTS ARE SILVER PLATED (15 MICRONS)
  4. MOVING CONTACT ASSEMBLY SHOWN IS FOR TURN & TWIST ASSEMBLY

For Pavani Power Systems Pvt. Ltd.  
( T. SESHAGIRI RAO )  
Managing Director

TRANSMISSION CORPORATION OF  
ANDHRA PRADESH LTD



MAIN SWITCH CONTACT ASSEMBLY  
( FOR 245kV, 1600A ISOLATOR)

REVISIONS	D	C	B	A
DATE	18-05-2023			
DRAWN				
CHECKED				
APPROVED				
SHEET	02 OF 09			
DRG.No:	PPSP1-APT-MSCA-A4-02			



PAVANI POWER SYSTEMS PVT.LTD.  
Plot No. 06/056/4/6, K.K. OVERSEAS SOCIETY,  
PDA, DULAPALLY, QUTHUBULLAPUR MANDAL,  
KODURU ROAD, HYDERABAD - 500100.  
KURUPAKA WALKER DIST. TELANGANA

Drawing approval subject to valid vendor registration

CHIEF ENGINEER/PROJECTS  
APTRANSCO/VS/VIJAYAWADA

NOTE: 1. Drawings Approval subject to valid type test reports, to be checked during

**Fixed Contact Assembly:**

2. For EPC contractors only.

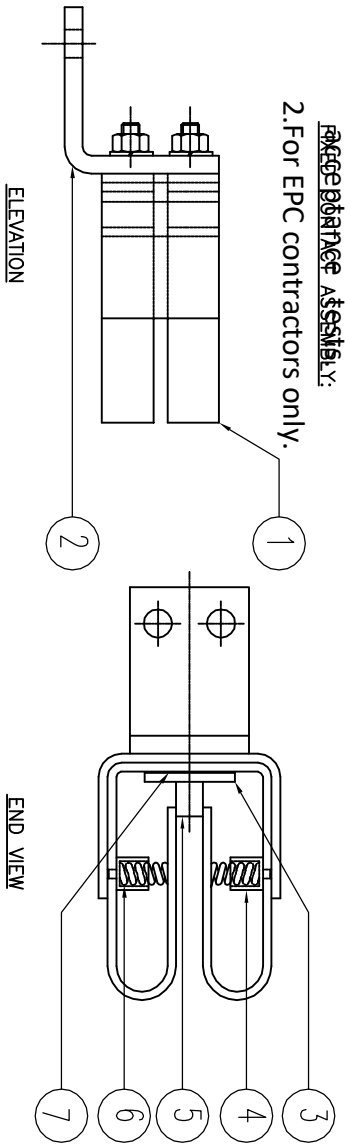

**MOVING CONTACT ASSEMBLY:**

Drawing approval subject to valid vendor registration

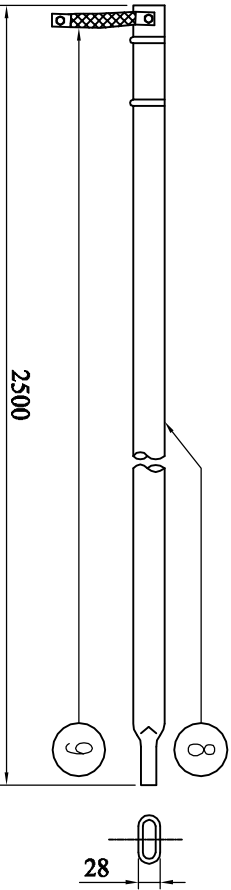

Since the supply of terminanal connectors is not in the scope of manufacturer as mentioned in the drawings. The EPC contractor shall be instructed to supply the same line with CT/PT/CVT/Isolator/IVT /LA /Breaker requirement and compability.

Live part to ground clearance shall be maintined during erection as per IE rules.

**PART LIST:**

1. JAWS (32 x 4 , 2 Nos. HDEC FLAT SILVER PLATED)
2. F.C. SUPPORT PLATE (8 mm THICK M.S. HDG)
3. JUMPER PLATE (75 x 12 AL. FLAT)
4. BUSH (NYLON)
5. SPACER (ALUMINIUM)
6. SPRINGS (ø2mm, STAINLESS STEEL WIRE)
7. MOVING CONTACT ASSEMBLY (38-ODX30-ID HDEC TUBE)
8. COPPER FLEXIBLE (25X4MM, 4NOS TIN PLATED)

**NOTE:**

1. ALL DIMENSIONS ARE IN MILLIMETER
2. ALL FERROUS PARTS ARE HOT DIP GALVANIZED (85 MICRONS)
3. ALL NON FERROUS CONTACT POINTS ARE SILVER PLATED (15 MICRONS)
4. NECESSARY BOLT, NUTS, PLAIN & SPRING WASHERS WILL BE FITTED WITH EQUIPMENT

**CHIEF ENGINEER/PROJECTS**  
**APTRANSCO/VS/VIJAYAWADA**

**For Pavani Power Systems Pvt. Ltd.**

**( T. SESHAGIRI RAO )**  
Managing Director

**TRANSMISSION CORPORATION OF ANDHRA PRADESH LTD**

<b>REVISIONS</b>		<b>TITLE:</b>	
D	C	BARTH SWITCH CONTACT ASSEMBLY	
B	A	( FOR 245KV, ISOLATOR)	
A		SCALE: 1:1	
		DATE	18-05-2023
		DRAWN	
		CHECKED	
		APPROVED	
		SHEET	03 OF 09
		DRG. NO.	PPSP1-APT-ESCA-44-03



**PAVANI POWER SYSTEMS PVT. LTD.**  
Plot No. 06/065/4/6, K.K. OVERSEAS SOCIETY,  
UDA, DULAPALLY, QUTHUBULLAPUR MANDAL,  
KOMURU FORT, HYDERABAD - 500100.  
MEDICAL MARKAIGER DIST. TELANGANA

NOTE: 1. Drawings Approval subject to valid type test reports, to be checked during acceptance tests.  
2. For EPC contractors only.

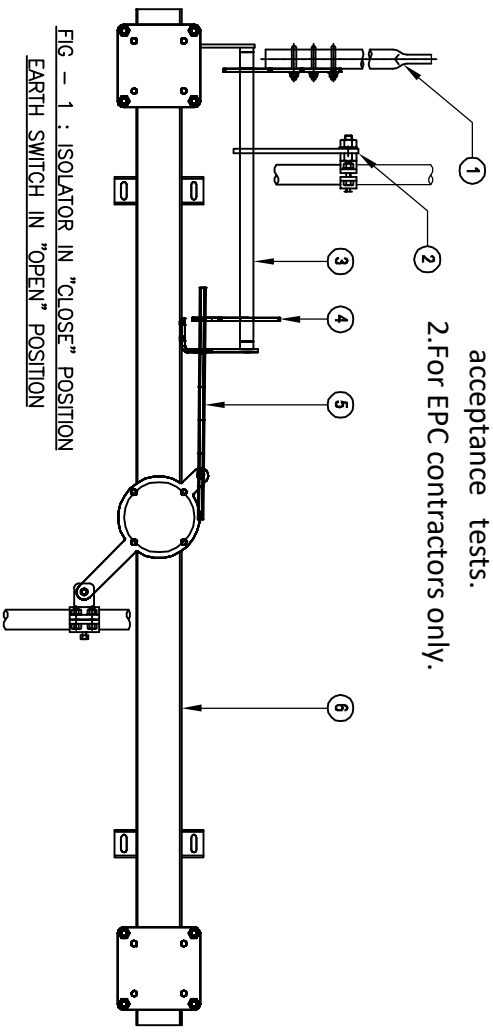

FIG - 1 : ISOLATOR IN "CLOSE" POSITION  
EARTH SWITCH IN "OPEN" POSITION

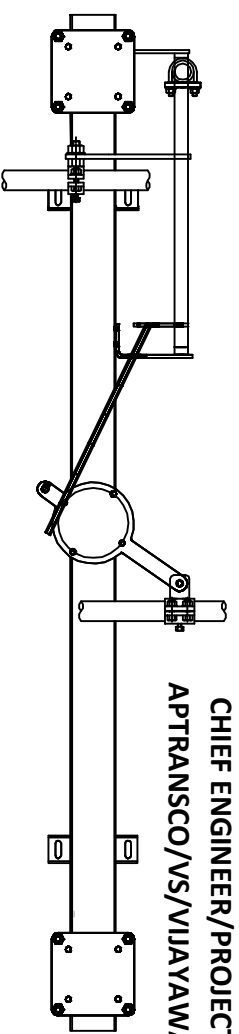

FIG - 2 : ISOLATOR IN "OPEN" POSITION  
EARTH SWITCH IN "CLOSE" POSITION

**CHIEF ENGINEER/PROJECTS**  
**APTRANSCO/VS/VIJAYAWADA**

Since the supply of terminal connectors is not in the scope of manufacturer as mentioned in the drawings. The EPC contractor shall be instructed to supply the same line with CT/PT/CVT/Isolator/VT/LA/Breaker requirement and capability.

Live part to ground clearance shall be maintained during erection as per IE rules.

Drawing approval subject to valid vendor registration

**CONSTRUCTION :**

E.S MOVING CONTACT (1), E.S OPERATING LEVER (2) & E.S STOPPER PLATE (4) ARE CONNECTED TO THE E.S ROTATING PIPE (3). ALSO MOVES ALONG WITH THE ROTATING PIPE (3) ISOLATOR OPERATING LEVER (6) IS CONNECTED TO THE STOPPER ROD (5) WHICH IS ACT AS A MECHANICAL STOPPER.

**FUNCTION :**

IN FIG-1: WHEN ISOLATOR IS IN CLOSE CONDITION THEN ISOLATOR OPERATING LEVER (6) CONNECTED TO STOPPER ROD (5) MOVES THROUGH STOPPER PLATE (4) AND LOCKED WHICH WILL NOT PERMIT TO MOVE E.S ROTATING PIPE (3) EARTH SWITCH MOVING CONTACT (1) TO CLOSE POSITION.

IN FIG-2: WHEN EARTH SWITCH IS IN CLOSE CONDITION THEN ISOLATOR OPERATING LEVER (6) CONNECTED TO STOPPER ROD (5) IS LOCKED WITH STOPPER PLATE(4) WHICH WILL NOT PERMIT TO MOVE ISOLATOR OPERATING LEVER (6) TO CLOSE CLOSE POSITION.

**NOTES :**

1. E.S. MOVING CONTACT ( 38 OD X 30 ID Cu. PIPE)
2. E.S. OPERATING LEVER ( 50 X 10mm THIK MS FLATE HDG)
3. E.S ROTATING PIPE ( 25 NB MS PIPE HDG)
4. STOPPER ROD (  $\phi$  25mm ROD MS HDG)
5. STOPPER PATE ( 6mm THIK PLATE MS HDG)
7. BASE CHANNEL (145X80X5mm Thk. RECTANGLE BOX M.S HDG)

**For Pavani Power Systems Pvt. Ltd.**  
**( T. SESHAGIRI RAO )**  
**Managing Director**



**TRANSMISSION CORPORATION OF**  
**ANDHRA PRADESH LTD**

<b>REVISIONS</b>		<b>TITLE:</b>	
D	C	MECHANICAL INTERLOCK BETWEEN MAIN SWITCH AND EARTH SWITCH	
B	A		
A			
		<b>AP TRANSCO</b>	
		 <p><b>PAVANI POWER SYSTEMS PVT.LTD.</b> Plot No. 06/056/4/6, K.K. OVERSEAS SOCIETY, IDA, DULAPALLY, QUTHUBULLAPUR MANDAL, KOMPAKU POST, HYDERABAD - 500100. NEOSRUL WALKER DIST. TELANGANA</p>	
		SCALE: 1:1	
		DATE	18-05-2023
		DRAWN	
		CHECKED	
		APPROVED	
		SHEET	04 OF 09
		DRG. NO.	PPSP-APT-MIL-A4-04

NOTE: 1. Drawings Approval subject to valid type test reports, to be checked during acceptance tests.  
2. For EPC contractors only.

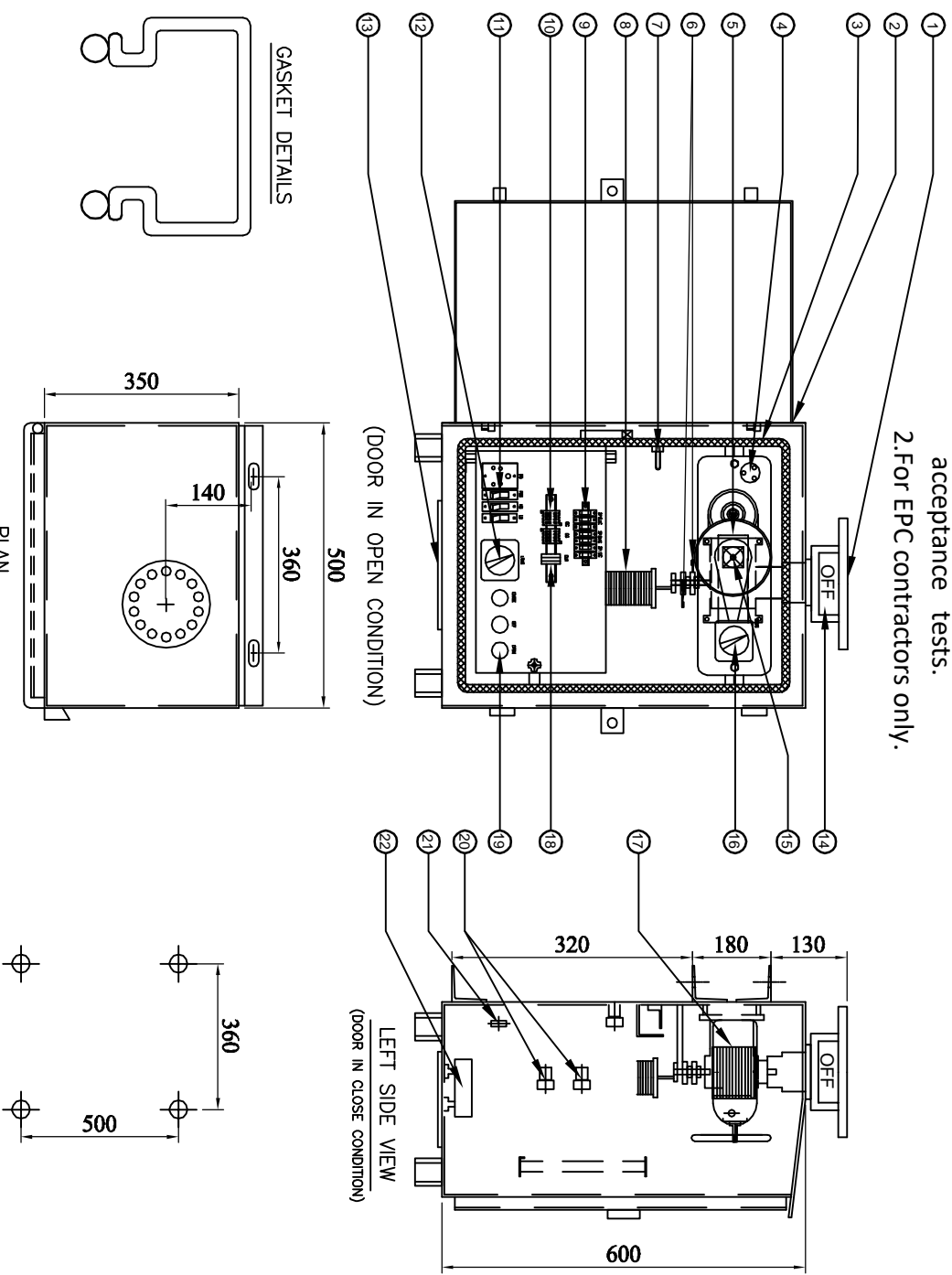

- PART LIST:-**
1. 14-HOLES FLANGE
  2. CUBICAL WITH DOOR (3mm Alu. SHEET)
  3. RUBBER GASKET (EPDM)
  4. THORMOSTAT (30°C TO 85°C)
  5. REDACTION GEAR BOX
  6. LIMIT SWITCHES (OPEN & CLOSE)
  7. CUBICLE LAMP HOLDER
  8. AUXILIARY SWITCH - 12NO+12NC
  9. 3-POLE MCB-FOR MOTOR SUPPLY  
2-POLE MCB-FOR SINGLE PHASE SUPPLY
  10. CONNECTORS FOR OPEN & CLOSE
  11. POWER SOCKET/LIGHT & HEATER SWITCHES
  12. LOCAL/REMOTE/MANUAL SELECTOR SWITCH
  13. DETACHABLE TYPE CABLE GLANDS PLATE
  14. ON/OFF INDICATOR
  15. MANUAL OPERATING ARRANGEMENT
  16. INTER LOCK ROTARY SWITCH
  17. MOTOR (0.5HP 415V AC, 50 Hz)
  18. OLR-OVER LODE RELAY
  19. PUSH BUTTONS
  20. TERMINAL BLOCK
  21. EARTHING TERMINAL-2 Nos.
  22. HEATER

Drawing approval subject to valid vendor registration

ALL DIMENSIONS ARE IN MILLIMETERS

CUBICLE WILL BE POWDER COATED WITH LIGHT GRAY SHADE NO:631 OF IS : 5  
DEGREE OF PROTECTION IP: 55 AS PER IS : 13947

20% SPARE TERMINALS WILL BE PROVIDED AND SHALL BE UNIFORMLY DISRIBUTED.  
TO ALL TERMINAL BLOCKS EQUALLY

WIRING WILL BE DONE WITH 1100V.GRADE 2.5 Sq.MM CU STRANDED P.V.C.  
INSULATED CONDUCTOR

WEIGHT OF THE BOX : 95Kg (APPROX.)  
PPSP PL MAKE REDUCTION GEAR RATIO:20:1 MATERIALS EN8/STEEL

CHIEF ENGINEER/PROJECTS  
APTRANSCO/VIS/VIJAYAWADA

For Pavani Power Systems Pvt. Ltd.  
( T. SESHAGIRI RAO )  
Managing Director



TRANSMISSION CORPORATION OF  
ANDHRA PRADESH LTD

REVISIONS		SCALE: N.T.	DATE	DRAWN	CHECKED	APPROVED	SHEET	DRA.G.N.O.
D	C							
PAVANI POWER SYSTEMS PVT.LTD. Plot No. 06/065/4/6, K.K. OPENERS SOCIETY, DDA, DULAPALLY, QUTHUBULLAPUR MANDAL, KODURUVA FORT, HYDERABAD - 500100. MICROFIL MANAGER DIST. TELANGANA		MOTOR OPERATING MECHANISM BOX (FOR 245KV ISOLATOR )		18-05-2023			05 OF 09	PPSP-APT-MOM-44-05

NOTE: 1. Drawings Approval subject to valid type test reports, to be checked during acceptance tests.

2. For EPC contractors on heavy 50Hz AC SUPPLY

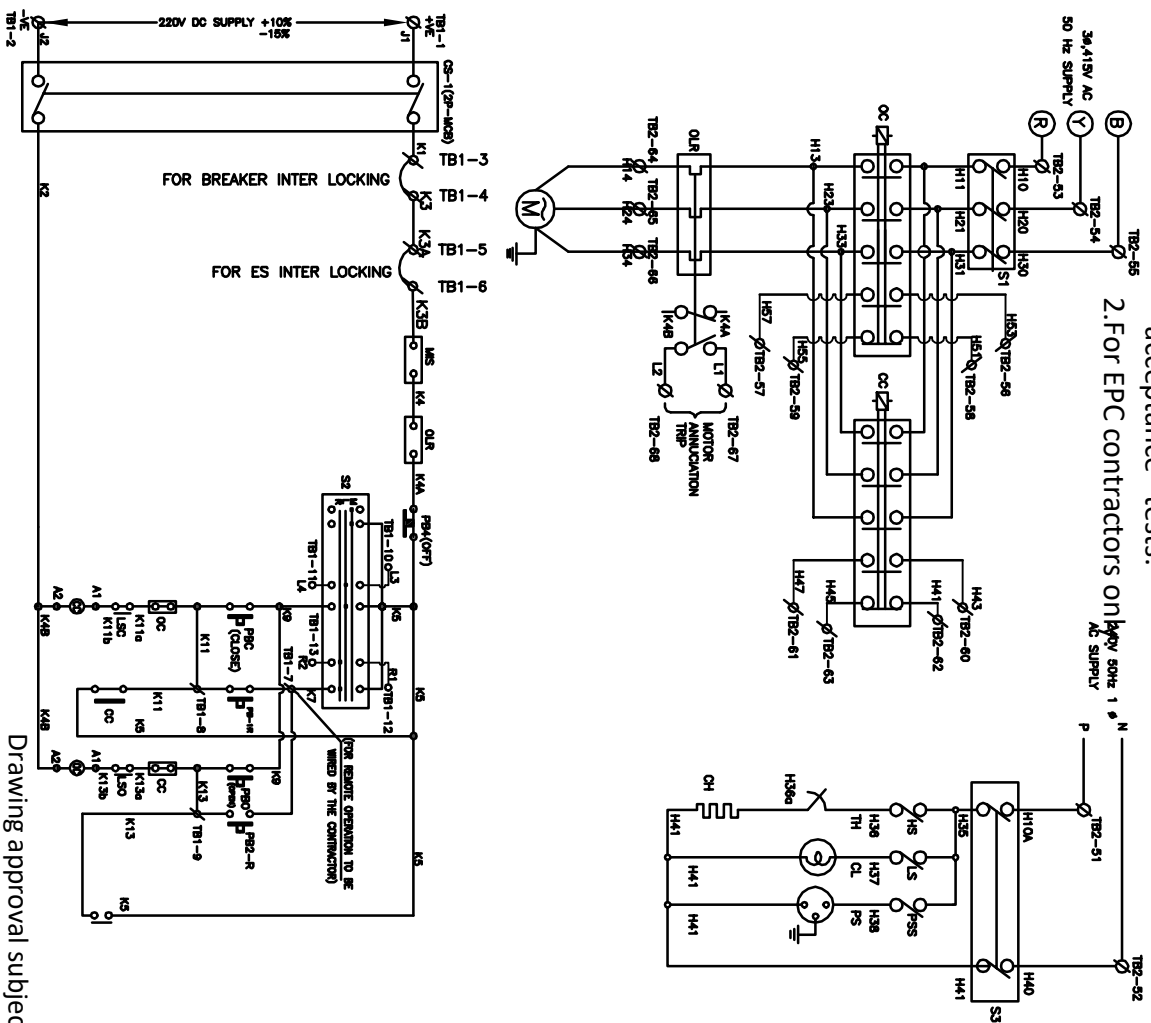

Drawing approval subject to valid vendor registration

LEGEND	DESCRIPTION	MAKE
CC & OC	Close & Open contactors 220V DC, 7A	C&S/ SIEMENS/ Schneider/ ABB
CS1&CS2	Compact fluorescent lamp	PROVISION FOR LAMP.
S3	Cubic heater (80W,240V)	Grish Ego./Kontakt Pyrosensors
HS	AC 3φ 415V MCB-6A for motor	C&S/ SIEMENS/ Schneider/ ABB
MIS	AC 1φ 240V MCB-16A for AC supply	C&S/ SIEMENS/ Schneider/ ABB
LS	AC 1φ 240V, 6A one way switch for heater	Anchor/MARU
LSC	Manual interlock switch	Recom/Kaycee/Jabdalji/MANI
LSD	Lamp switch 240V, 6A one way switch	Anchor/MARU
OLR	Opens when the isolator opens, 10A 1NO+1NC	JAI BALAJI/MANI
PBC & PBO	Thermostat 30° to 85°C	Bhoskary/Mavis/Grish EGO
	Over load relay with SPP (1.0A TO 1.6A)	C&S/ SIEMENS/ Schneider/ ABB
	Close and open push buttons, 10A	Vishnov/Siemens/Schneider/C&S
	Power socket 6A, 1φ, 3pin, 230V	Anchor/CGL OR Equip.
	Power socket 6A, 1φ, 3pin, 230V	Anchor / Maru OR Equip.
	AC 1φ 230V one way switch	Anchor/Maru
	Local / Remote / Manual selector switch	Recom/Kaycee/Jabdalji/MANI
	Motor (0.5 HP 3φ 415V AC, 50Hz)	REMI/LHP/ELCEN/CGL
	08NO + 08 NC	Power Drives/Imax/Mani's
AUX SWITCH	Push button to OFF the circuit 10 A	Vishnov/Siemens/Schneider/C&S
	Terminal block.	Vin Mech/Elmex/Connectwell

**OPERATING INSTRUCTIONS:**

1. Operation is possible only when the breaker is 'OPEN' ensure this condition is satisfied
2. For manual operation of isolator follow the following steps:
  - i) Keep selector switch (s2) in manual position.
  - ii) Rotate the rotary switch provided on the top panel board, insert the handle for the manual operation.
  - iii) Rotate the handle clockwise / anticlockwise to open / close the isolator respectively
  - iv) When the manual operation is not needed restore the position of rotary switch on top panel

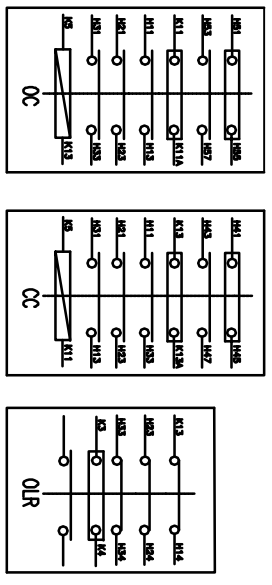

CHIEF ENGINEER/PROJECTS  
APTRANSCO/VS/VIJAYAWADA



**TRANSMISSION CORPORATION OF ANDHRA PRADESH LTD**

**For Pavani Power Systems Pvt. Ltd.**

**( T. SESHAGIRI RAO )**  
Managing Director

<b>AP TRANSCO</b>	
SCHEMATIC DIAGRAM	FOR MOTOR / DC CONTROL PANEL
PAVANI POWER SYSTEMS PVT.LTD.	
Plot No. 06/065/4/6, K.K. OVERSEAS SOCIETY, DDA, DULAPALLY, QUTHUBULLAPURU MANDAL, KOMURUVA FORT, HYDERABAD - 500100. MEDICAL MALAKGER DIST. TELANGANA	
SCALE: 1:1	DATE: 18-05-2023
DRAWN	CHECKED
APPROVED	SHEET: 06 OF 09
DESIGN: PPSPT-APT-SD-A4-06	

NOTE: 1. Drawings Approval subject to valid type test reports, to be checked during acceptance tests.  
2. For EPC contractors only.

AUX. SWITCH 12NO / 12NC

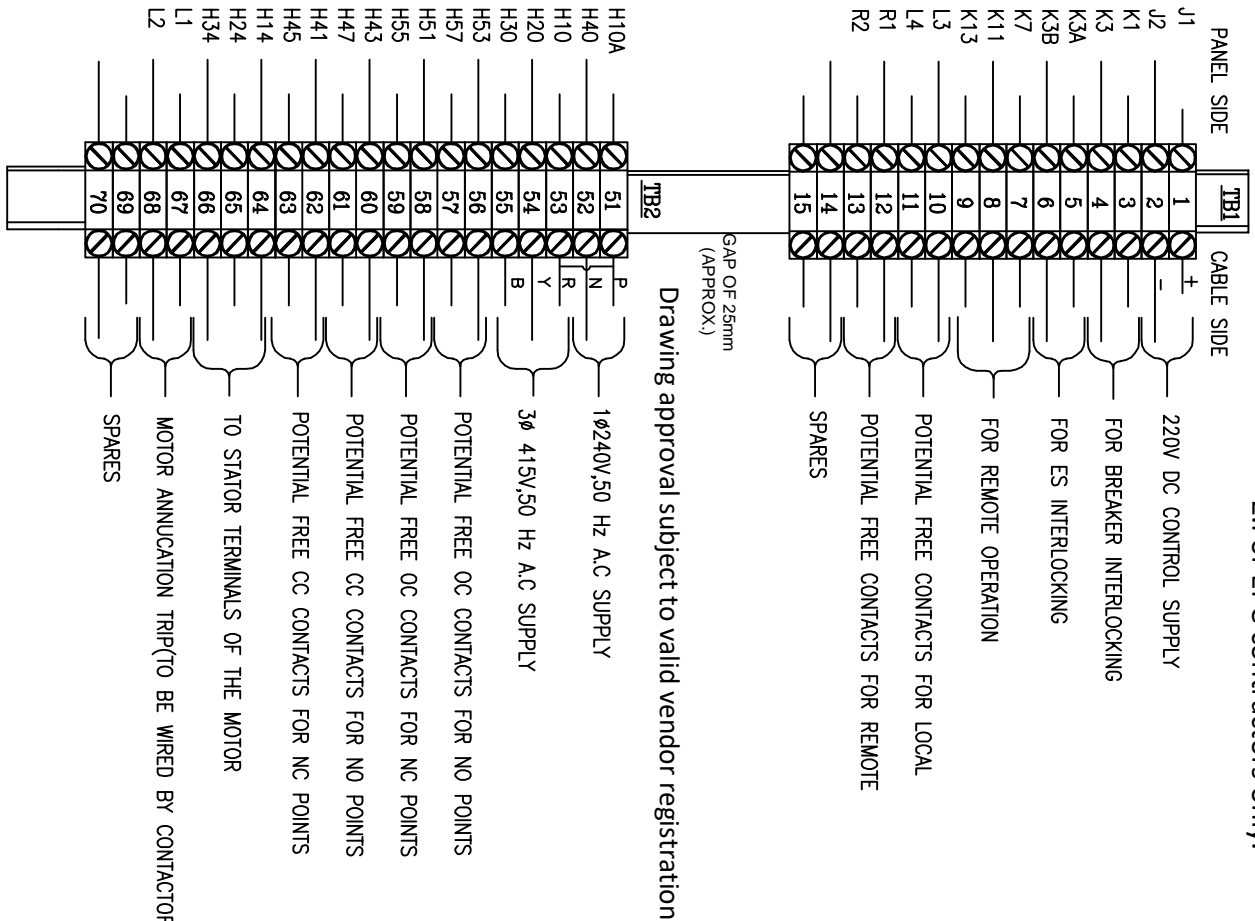

Drawing approval subject to valid vendor registration

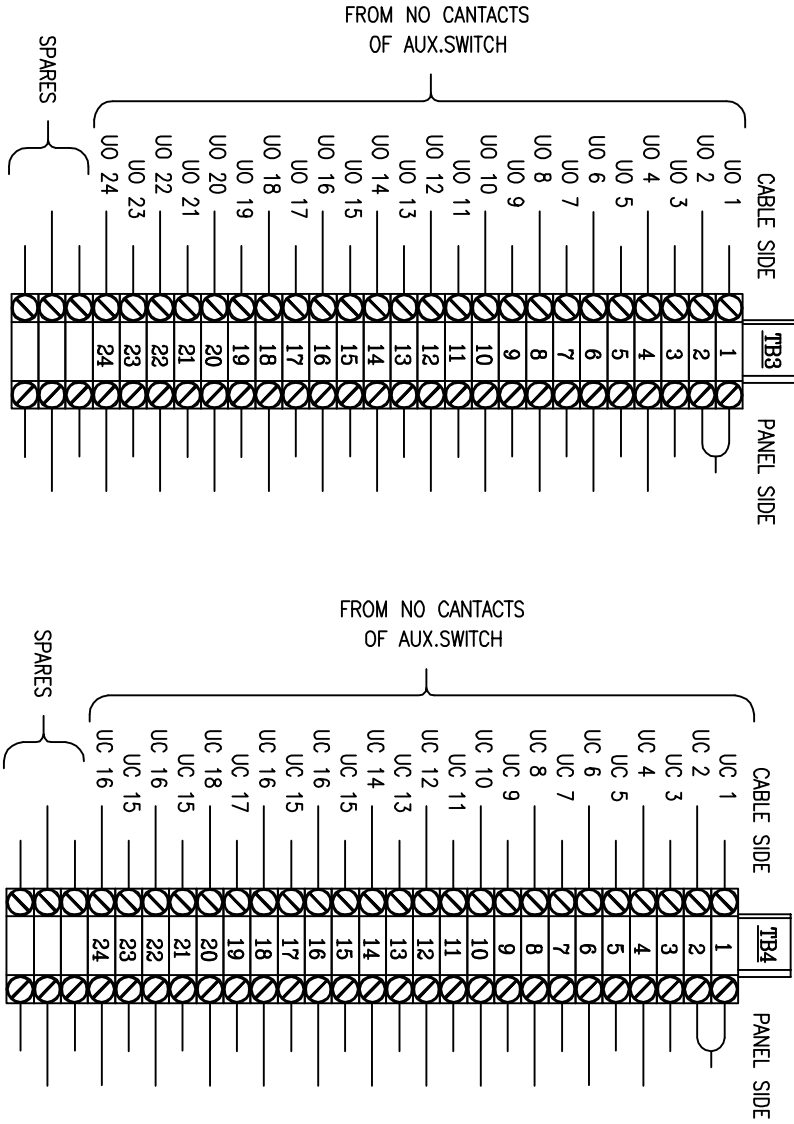

CHIEF ENGINEER/PROJECTS  
APTRANSCO/VS/VIJAYAWADA

For Pavani Power Systems Pvt. Ltd.  
(T. SESHAGIRI RAO)  
Managing Director

Since the supply of terminal connectors is not in the scope of manufacturer as mentioned in the drawings. The EPC contractor shall be instructed to supply the same line with VT/PT/CVT/isolator/VT/LA/Breaker requirement and capability.

7622017/2023/EEMRT-ENE51



**TRANSMISSION CORPORATION OF ANDHRA PRADESH LTD**

**TERMINAL BLOCK DETAILS**

REVISONS	D	C	B	A

SCALE: 1:1

DATE: 18-05-2023

DRAWN: [Signature]

CHECKED: [Signature]

APPROVED: [Signature]

SHEET: 07 OF 09

DRG. NO: PPSPT-APT-TBD-44-07

**PAYANI POWER SYSTEMS PVT. LTD.**  
Plot No. 06/056/4/6, K.K. OVERSEAS SOCIETY,  
IDA, DULLAPALLY, QUTHUBULLAPUR MANDAL,  
KOMURUJI POST, HYDERABAD - 500100.  
REGIONAL MANAGER DIST. TELANGANA

NOTE: 1. Drawings Approval subject to valid type test reports, to be checked during acceptance tests.

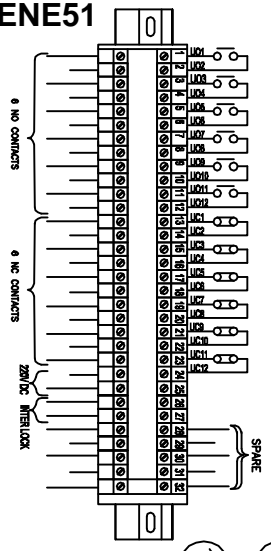
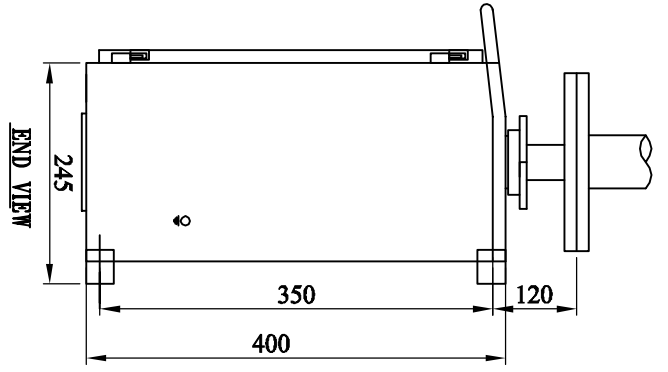

AUX. SWITCH CONTACT DETAILS FOR ISOLATOR (6 NO + 6 NC )

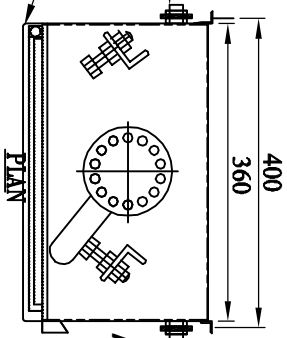
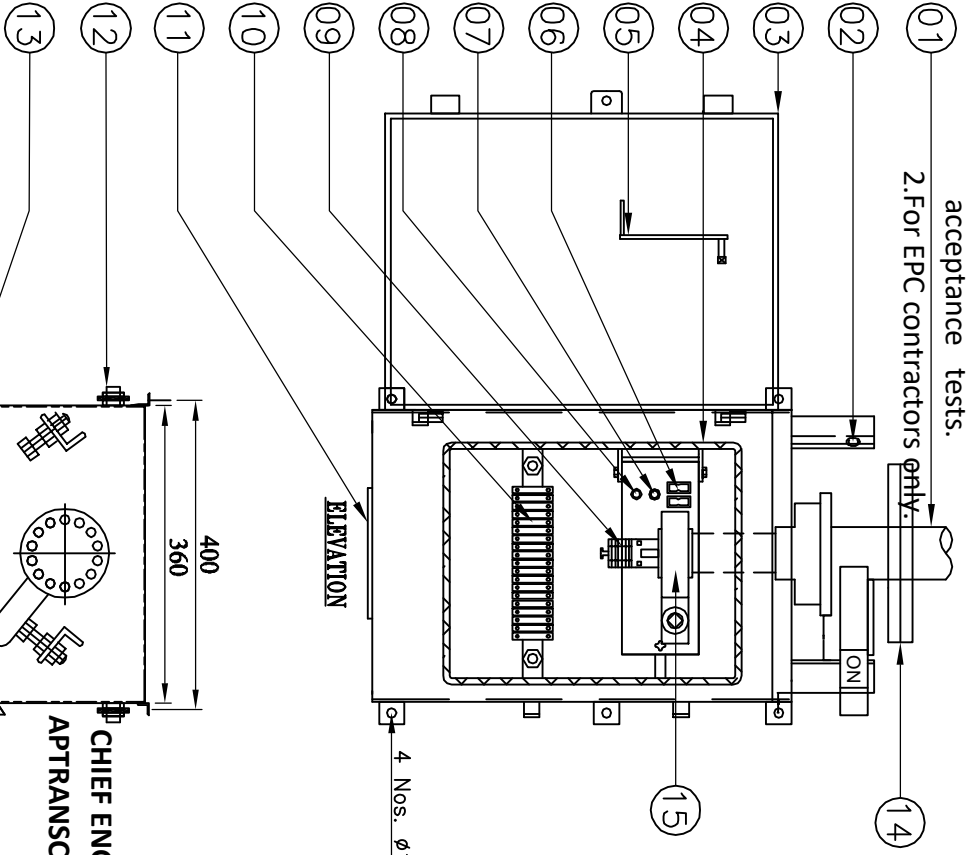

Drawing approval subject to valid vendor registration

PART LIST:-

1. DOWN PIPE
2. ON & OFF STOPPER
3. CUBICAL WITH DOOR 3.mm Alu. SHEET)
4. RUBBER GASKET (EPDM)
5. OPERATING HANDLE
6. FUSES (2A)
7. INDICATION LAMP
8. PUSH BUTTON
9. AUXILIARY SWITCH 6NO + 6NC
10. TERMINAL BLOCK(UBT-4 (VINMECH OR EQVT.))
11. DETACHABLE TYPE CABLE GLANDS PLATE
12. EARTHING TERMINAL-2 Nos.
13. RAIN SHADE
14. 12/14 HOLES FLANGE 8MM THK. (M.S HDG)
15. REDUCTION GEAR BOX

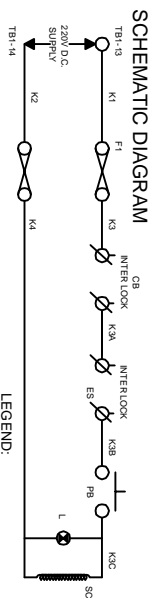

LEGEND:  
 F1 F2-----FUSES (2amp Rating)  
 PB-----PUSH BUTTON  
 L-----INDICATION LAMP  
 SC-----SOLENOID COIL

CHIEF ENGINEER/PROJECTS  
 APTRANSCO/VS/VIJAYAWADA

( T. SESHAGIRI RAO )  
 Managing Director  
 For Pavani Power Systems Pvt. Ltd.

ALL DIMENSIONS ARE IN MILLIMETERS  
 CUBICLE WILL BE POWDER COATED WITH LIGHT GRAY SHADE NO:631 OF IS : 5  
 DEGREE OF PROTECTION IP: 55 AS PER IS :13947  
 20% SPARE TERMINALS WILL BE PROVIDED AND SHALL BE UNIFORMLY DISRIBUTED  
 TO ALL TERMINAL BLOCKS EQUALLY  
 WIRING WILL BE DONE WITH 1100V.GRADE 2.5 Sq.MM CU STRANDED P.V.C.  
 INSULATED CONDUCTOR  
 WEIGHT OF THE BOX : 35Kg (APPROX.)  
 PPSPL MAKE REDUCTION GEAR RATIO:20:1 MATERIALS EN8/STEEL

REVISIONS		SCALE: 1:1	
D	C	18-05-2023	
B	A	DRAWN	
A		CHECKED	
		APPROVED	08-07-09
		SHEET	08-07-09
		DRG. NO.	PPSPPL-APT-RES-44-08

**AP TRANSCO**

**TRANSMISSION CORPORATION OF ANDHRA PRADESH LTD**

MANUAL OPERATING MECHANISM BOX  
 ( FOR 245kV EARTH SWITCH )

PAVANI POWER SYSTEMS PVT.LTD.  
 Plot No. 06/056/4/6, K.K. OPENERS SOCIETY,  
 DDA, DULAPALLY, QUTHUBULLAPUR MANDAL,  
 KODURU ROAD, HYDERABAD - 500100.  
 REGIONAL MANAGER DIST. TELANGANA

NOTE: 1. Drawings Approval subject to valid type test reports, to be checked during acceptance tests.  
 2. For EPC contractors only.

 MANUFACTURED & SUPPLIED BY <b>PAVANI POWER SYSTEMS PVT.LTD.</b> PLOT No.05/055/A/6, K.K.OWNERS SOCIETY, DULAPALLY INDUSTRIAL AREA, KOMMIPALLY POST, HYDERABAD-500100. MEDICAL MALKAJGIRI DIST. T.S.	
<b>ISOLATOR RATING NAME PLATE</b>	
CLIENT:	TRANSMISSION CORPORATION OF A.P LTD
CUSTOMER:	---
PO.No./DATE:	---
YEAR OF MFG.	---
TYPE	DBR
VOLTAGE (kV)	245
STC kA/SEC.	50/3
CURRENT (A)	1600
SL.No.	---
FREQUENCY (Hz)	50
I.W. VOLTAGE	1050kVp
P.F.W. VOLTAGE(DRY)	460kVrms
OPERATING DRIVE	MOTOR
CONTROL VOLTAGE	220 V DC

 MANUFACTURED & SUPPLIED BY <b>PAVANI POWER SYSTEMS PVT.LTD.</b> PLOT No.05/055/A/6, K.K.OWNERS SOCIETY, DULAPALLY INDUSTRIAL AREA, KOMMIPALLY POST, HYDERABAD-500100. MEDICAL MALKAJGIRI DIST. T.S.	
<b>ISOLATOR RATING NAME PLATE</b>	
CLIENT:	TRANSMISSION CORPORATION OF A.P LTD
CUSTOMER:	---
PO.No./DATE:	---
YEAR OF MFG.	---
TYPE	VERTICAL
VOLTAGE (kV)	245
STC kA/SEC.	50/1
CURRENT (A)	---
SL.No.	---
FREQUENCY (Hz)	50
I.W. VOLTAGE	1050kVp
P.F.W. VOLTAGE(DRY)	460kVrms
OPERATING DRIVE	MANUAL
CONTROL VOLTAGE	220 V DC

Drawing approval subject to valid vendor registration

**CHIEF ENGINEER/PROJECTS**  
**APTRANSCO/VS/VIJAYAWADA**

( T. SESHAGIRI RAO )  
 Managing Director

For Pavani Power Systems Pvt. Ltd.

Since the supply of terminal connectors is not in the scope of manufacturer as mentioned in the drawings. The EPC contractor shall be instructed to supply the same line with CT/PT/CVT/Isolator/VT /LA /Breaker requirement and compability.

 TRANSMISSION CORPORATION OF <b>ANDHRA PRADESH LTD</b>	
NAME PLATE DETAILS ( FOR 245kV, ISOLATOR AND E.S )	
SCALE: 1:1	DATE: 18-05-2023
DRAWN:	CHECKED:
APPROVED:	SHEET: 09 OF 09
DRG.No: PPSPT-APT-NPD-44-09	