

TRANSMISSION CORPORATION OF ANDHRA PRADESH LTD.

GUARANTEED TECHNICAL PARTICULARS FOR 245KV 1600A HDB ISOLATOR WITH SINGLE EARTH SWITCH

S.No	DESCRIPTION	GUARANTEED VALUE
1	Type / Installation	: "DBR' Double Break Center post rotating type" / Outdoor installation
2	Manufacturer's Name and Country of Manufacture	: PAVANI POWR SYSYEM PVT LTD. INDIA
3	Standards according to which the isolators are manufactured	: IS: 9921 - Part-I to V / IEC:62271-102
4	Miximum design voltage at which the isolator can operate (kV)	: 245 Drawing approval subject to valid vendor registration
5	Frequency (Hz)	: 50
6	Rated voltage (kV)	: 220
7	Maximum current that can be safely interrupted by the isolator Inductive (A & % PF) Capacitive (A & % PF)	: Inductive- 0.7 Amps at 0.15 p.f. Capacitive- 0.7 Amps at 0.15 p.f.
8	Continuous current rating Nominal (Amps) under site conditions	: 1600
9	Rated short time current	: MAIN SWITCH / EARTH SWITCH.
	i) For 3 seconds (kA rms)	: 40 / 50KA 3.Sec.
	ii) For 1 second (kA rms)	: Not applicable
	iii) Rated peak short time current (kVp)	: 100 / 125
10	Current density at the minimum cross-section of	: Contact sizes indicated in Annexure - III of specification & as per the property of materials.
	a) Moving blade (Amps/ Sq.mm) Cu. Tube	: 2.0 Amps / Sq.mm for HDE Cu. Tube
	b) Terminal pad : Aluminum Flat	: 1.0 Amp/ Sq.mm for EC grade Alu. Flat
	c) Contacts : Cu.Flat	: 1.6 Amps/Sq.mm for HDE Cu. Flat
	d) Terminal connector : Aluminm Casting	: 1.0 Amps/Sq.mm for Alu. Alloy.
11	Maximum Temp. Rise of current carrying parts when carrying rated current continuously (deg.C)	: Within the specified limits of IS: 9921 - PartII/ IEC-62271-102
12	Insulation Levels	:
	i) Impulse withstand voltage (kV peak) phase to earth across isolating distance:	: 1050/ 1200 kV peak
	ii) Switching surge withstand voltage (kV peak) phase to earth across isolating distance	: Not applicable
	iii) Power frequency withstand voltage (kV rms) Phase to earth isolating distance	: 460/ 530 kV rms
13	Minimum clearance in air	:
	i) Between poles (mm)	: Phase spacing of 4500 mm
	ii) Between live parts and earth (mm)	: 2100 mm (Equal to dry arcing distance of insulators selected)
	iii) Between live parts when switch is open	:
	a) On the same pole (mm)	: 3200
	b) Between adjacent poles (mm)	: 4500

CHIEF ENGINEER/PROJECTS
APTRANSCO/VS/VIJAYAWADA

Since the supply of terminanal connectors is not in the scope of manufacturer as mentioned in the drawings. The EPC contractor shall be instructed to supply the same line with CT/PT/CVT/Isolator/IVT /LA /Breaker requirement and campability.

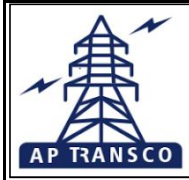

TRANSMISSION CORPORATION OF ANDHRA PRADESH LTD.

GUARANTEED TECHNICAL PARTICULARS FOR 245KV 1600A HDB ISOLATOR WITH SINGLE EARTH SWITCH

S.No	DESCRIPTION		GUARANTEED VALUE
15	Rated mechanical terminal load		:
	i)	Load along the terminal connector side (Kg.)	: 102
	ii)	Load across the terminal connector side (Kg.)	: 33.7
16	Torque required to operated the switch in Kg.m		: 40 CHIEF ENGINEER/PROJECTS
17	Design and Construction		APTRANSCO/VS/VIJAYAWADA
	i)	No. of insulators per pole	: Three
	ii)	No. of breaks per pole	: Two
	iii)	Type of closing / opening mechanism (Horizontal/Vertical break straight etc.)	: Horizontal double break
	iv)	Contacts	:
	a)	Material and grade	: Hard drawn electrolytic copper flat, contact area is silver plated (15 Microns)
	b)	Cross-sectional area (mm)	: 1017.6 sq.mm for 1600 Amps
	v)	Moving blades	:
	a)	Material and grade	: Hard drawn electrolytic copper flat, contact area is silver plated (15 Microns)
	b)	Cross-sectional area (mm)	: 829 sq.mm for 1600 Amps
	vi)	Contact support	:
	a)	Material and size of channel/block	: 4 mm thick, MS HDG
	b)	Material and size of plate	: 6 mm thick, MS HDG Plate
	vii)	Rain hood - Material grade and size	: 1mm GI Sheet
	viii)	Turn and twist mechanism	:
	a)	Material and size of clamps	: 50 x 10 mm thick, MS HDG flat.
	b)	Maerial size of springs	: 3.0 mm Stainless steel wire
	c)	Whether springs are encased	: Not encased.
	ix)	Nuts and Bolts	:
	a)	Size, material and grade in live parts	: Less than M12: Stainless steel
	b)	Size, material and grade in other parts	: M12 and above: MS HDG.
	x)	Insulator base plate material and size of plate below insulators	: 270 x 270 mm X 12mm MS HDG plate
	xi)	Bearings	:
	a)	Material and size of housing	: MS HDG suitable for 40 ID tapper roller/ ball bearing.
	b)	No. of bearings, location and size	: 2 Nos . Below centre rotating post insulator.

Since the supply of terminanal connectors is not in the scope of manufacturer as mentioned in the drawings. The EPC contractor shall be instructed to supply the same line with CT/PT/CVT/Isolator/IVT /LA /Breaker requirement and campability.



TRANSMISSION CORPORATION OF ANDHRA PRADESH LTD.

GUARANTEED TECHNICAL PARTICULARS FOR 245KV 1600A HDB ISOLATOR WITH SINGLE EARTH SWITCH

S.No	DESCRIPTION	GUARANTEED VALUE
xii)	Tandem pipe	:
	a) Size, class and No. of pipes	: 32mm NB Class B,GI Pipe for Main switch-2Nos for Earth switch-1No.
	b) Size of shackle, screw	: Suitable for 32mm NB GI Pipe
	c) No. of bearings/bush and its material and size	: Not applicable
xiii)	Type of interlock	: Electrical interlock between isolator and correspondin breaker / Mechanical interlock between M.S & E.S.
xiv)	Down pipe size and class	: 50 NB Class B GI pipe
xv)	Type of universal/swivel joint	:
	a) Between bearing and down pipe	: Universal joint
	b) Between down pipe and operating mechanism	: Vernier flange
xvi)	Operating mechanism	: Motor operated mechanism for main switch and manual operated mechanism with reduction gear for earth switch.
	a) Control cabinet material and thickness	: 3.mm THK Aluminum Sheet
	b) Degree of protection	: IP: 55 as per IS: 2147
	c) Type, size and No. of cable glands	: Double compression type 2Nos. 19 mm (Contractor scope of supply)
	d) Whether removable gland plate provided	: Yes, provided.
	e) Make, type, rating and quantity of motors	: HE/CGL/Remi or Eqvt. 3 Phase, 415 V, 0.5 HP
	f) Auxilliary blocks	: 12 NO + 12 NC Contacts for main switch, 6 NO + 6 NC Contacts for Earth switch, 10 Amps, 2 A DC Breaking with 2A - 1 No.
	g) Terminal blocks	: UBT-4
	i) Insulated wires	: 1100 V grades, 2.5 Sq.mm PVC For Auxilliary Circuit and 2.5 Sq.mm for Power cricuit.
	j) HRC Fuse / MCB	: C&S/Siemns/ABB or Eqvt.
	k) Space Heater	: 1 No. 230 V AC - 80 watts
	l) Interlocks	: with Rotary switch Kaycee or Eqvt.
xvii)	Base:	:
	a) Size of steel section used	: 145x80x5mm Rectangle box profile(M.S.HDG)
	b) Overall sie	: 145 x 80 x 3560 mm
	c) Total weight.	: 95Kgs (Approx.) one pole
18	List of drawings furnished.	: Enclosed.
	Name of the firm	: For Pavani Power Systems Pvt. Ltd.
	Signature of Bidder	:
	Designation & Seal	: (T. SESHAGIRI RAO) Managing Director
	CHIEF ENGINEER/PROJECTS APTRANSCO/VS/VIJAYAWADA	Date : 18-05-2023

NOTE: 1. Drawings Approval subject to valid type test reports, to be checked during acceptance tests.
2. For EPC contractor's authority.

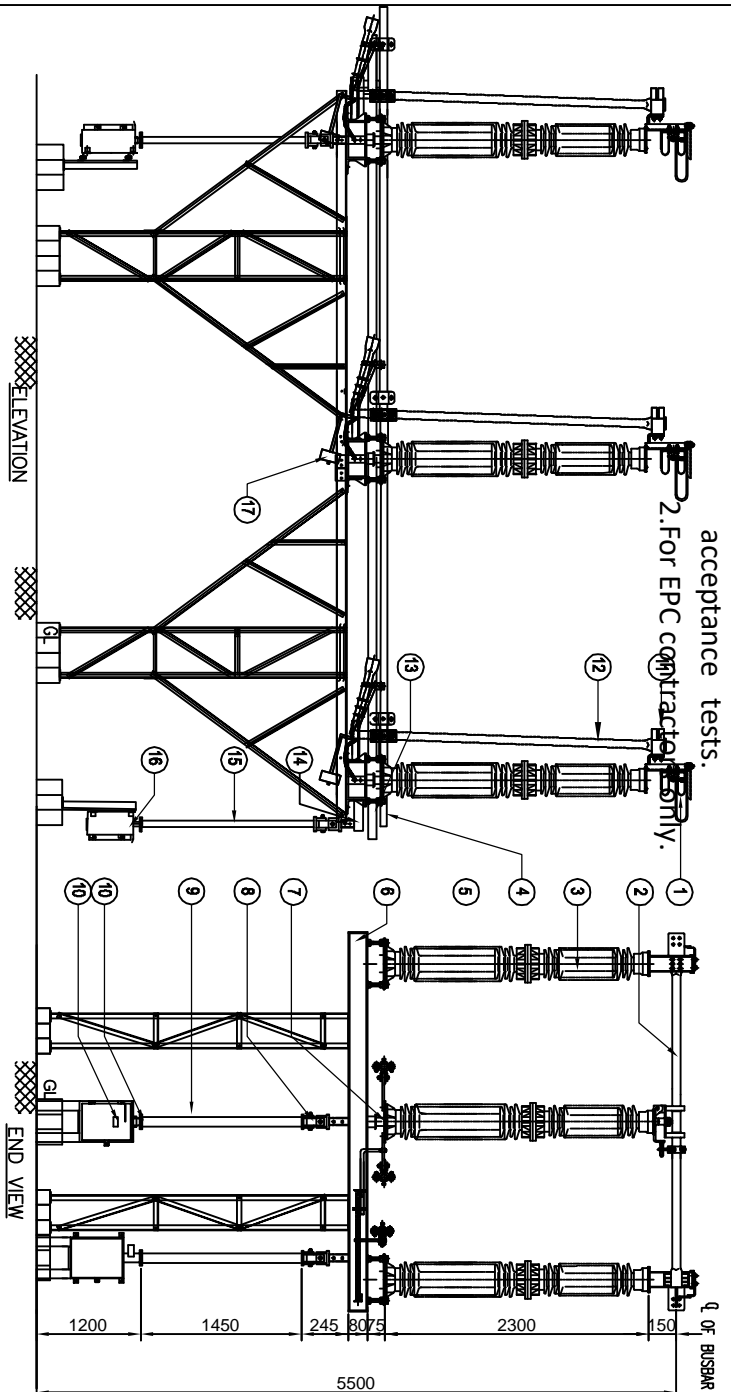

ELEVATION
Drawing approval subject to valid vendor registration
END VIEW

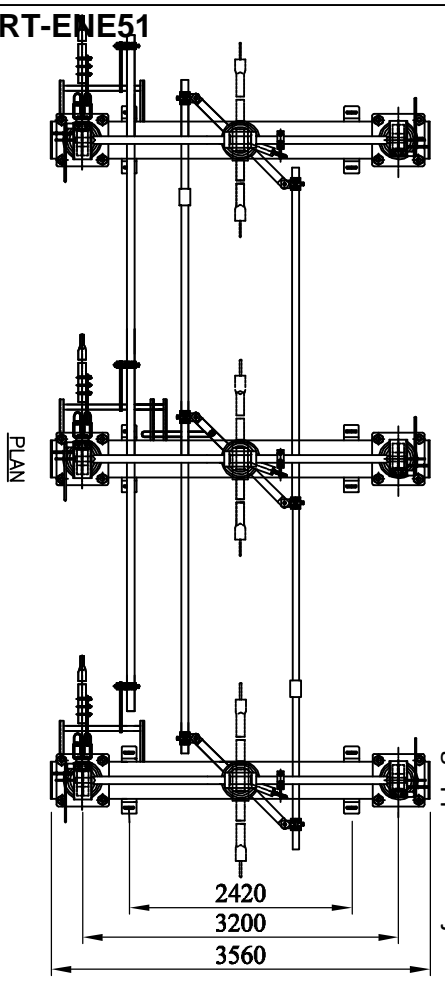

PLAN

18 X 36 SLOT HOLES

2420

INSULATOR FIXING DETAILS
4Nos. Ø18 HOLES ON 225 P.C.D.
4Nos. Ø16 TAP HOLES ON 127 P.C.D.

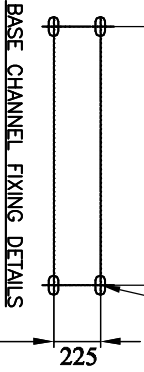
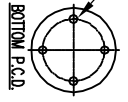

7622110/2023/EMMRT-ENE51

PART LIST:

1. FIXED CONTACT ASSEMBLY
2. MOVING CONTACT ASSEMBLY
3. INSULATOR STACK (COSTUMER SCOPE)
4. TANDEM PIPE FOR ISOLATOR (32NB, CLASS "B" G.I PIPE)
5. ELEVATOR PLATE (270X270X12MM THK M.S HDG)
6. BASE CHANNEL (145 X 80 X 5MM THK. M.S HDG)
7. ROTATING STOOL BASE WITH LEVER ARM & CLAMP (M.S HDG)
8. OPERATING PIPE CONNECTING BUSH (M.S HDG)
9. DOWN PIPE FOR ISOLATOR (50NB CLASS"B" G.I PIPE)
10. MOTOR OPERATING MECHANISM FOR ISOLATOR
11. E.S FIXED CONTACT ASSEMBLY
12. E.S MOVING CONTACT ASSEMBLY
13. TANDEM PIPE FOR E.S (32NB CLASS "B" G.I PIPE)
14. TOP OPERATING MECHANISM FOR EARTH SWITCH (M.S HDG)
15. DOWN PIPE FOR E.S (50NB CLASS "B" G.I PIPE)
16. MANUAL OPERATING MECHANISM FOR E.S (RG BOX)
17. COUNTER WEIGHT FOR E.S (Per pole 10Kgs Approx.)

REFERENCE DRAWINGS:

1. FOR ISOLATOR CONTACT ASSEMBLY (1600 AMPS)
2. FOR EARTH SWITCH CONTACT ASSEMBLY
3. FOR MOTOR OPERATED MECHANISM FOR MAIN SWITCH
4. FOR MANUAL OPERATED MECHANISM FOR EARTH SWITCH
5. FOR MECHANICAL INTERLOCK BETWEEN ISOLATORS AND EARTH SWITCH.
6. FOR SCHEMATIC DIAGRAM
7. FOR TERMINAL BLOCK DETAILS
8. FOR NAME PLATE DETAILS

NOTE: 1. ALL DIMENSIONS ARE IN MILLIMETERS

2. THE INDICATED DIMENSIONS ARE SUBJECT TO THE MANUFACTURING TOLERANCE:

- UP TO 50mm -----±3%; 51 TO 100mm ----- ±2%
- 101 TO 300mm -----± 1%; ABOVE 300mm -----±0.5%
- 3. SHORT TIME CURRENT RATING 40KA/50KA rms FOR 3 Sec.
- 4. MIN. CREEPAGE DISTANCE 3625 mm(25mm/KV)
- 5. APPLICABLE STANDARD : IEC: 62271-102
- 6. ALL FERROUS PARTS ARE HOT DIP GALVANIZED (85MICRONS)

CHIEF ENGINEER/PROJECTS
APTRANSCO/VS/VIJAYAWADA



TRANSMISSION CORPORATION OF
ANDHRA PRADESH LTD

(T. SESHAGIRI RAO)
Managing Director

For Pavani Power Systems Pvt. Ltd.

REVISIONS		TITLE	
D	C	AP TRANSCO	
B	B	245KV, 1600A, TP, HDB, RT, ISOLATOR WITH SINGLE E.S.	
A	A	(WITH MOTOR OPERATING MECHANISM)	
P		P	
D		D	
C		C	
B		B	
A		A	
SCALE: 1:1		DATE: 18-05-2023	
DRAWN		CHECKED	
APPROVED		SHEET: 01 OF 09	
SHEET		DESIGN: PPSPT-APT-GAD-44-01	
DESIGN		DATE	



PAVANI POWER SYSTEMS PVT.LTD.
Plot No. 06/065/4/6, K.K. OPREMS SOCIETY,
KODURU ROAD, HITEERABAD - 500100.
MEDICAL WALKER DIST. TELANGANA

FIXED CONTACT ASSEMBLY:

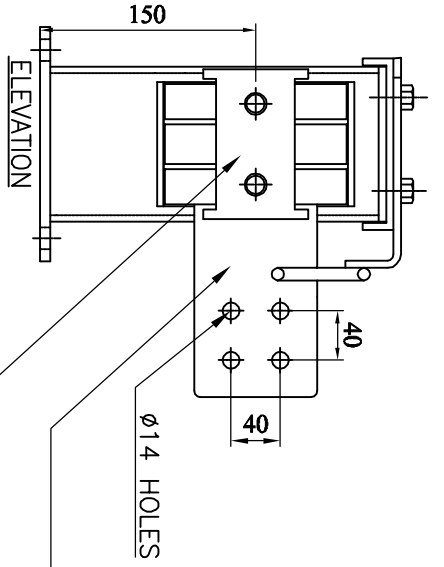

NOTE: 1. Drawings Approval subject to valid type test reports, to be checked during

- 1 acceptance tests.
- 2. For EPC contractors only.

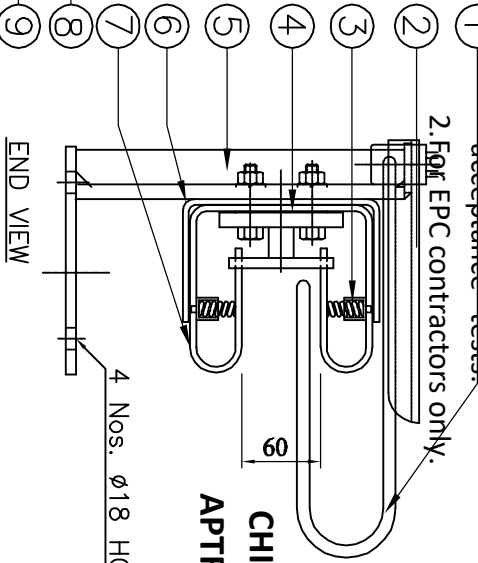

CHIEF ENGINEER /PROJECTS
APTRANSCO/VS/VIJAYAWADA

MOVING CONTACT ASSEMBLY:

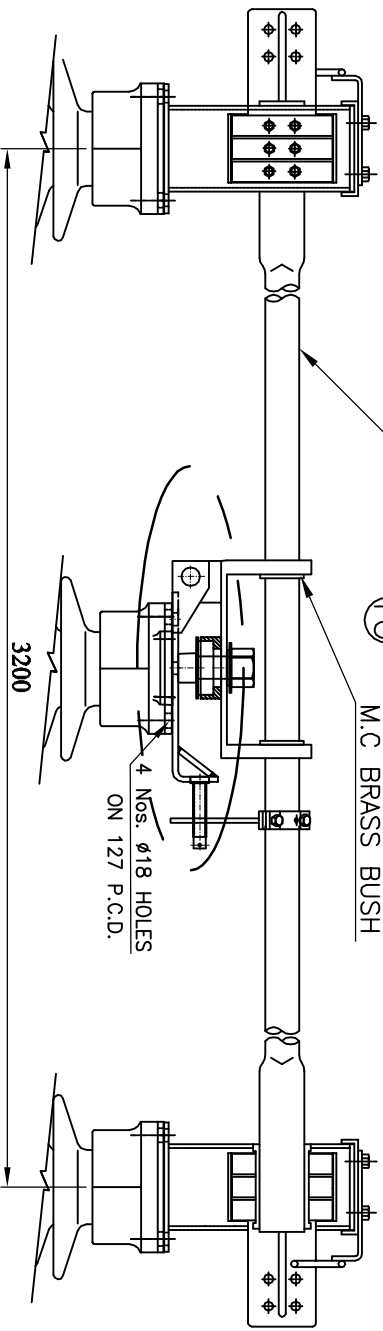

ELEVATION Drawing approval subject to valid vendor registration

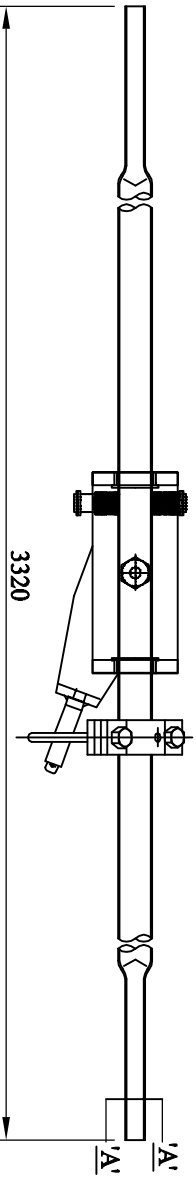

SL NO.	DESCRIPTION	SIZE IN MM	MATERIAL
1.	ARCING HORNS	φ10MM ROD	M.S HDG
2.	RAIN HOOD	1MM SHEET	M.S HDG
3.	JAW SPRINGS	φ2mm WIRE	STAINLESS STEEL
4.	BI-METALLIC SHEET	2mm THK	ALU. + CU.
5.	FIXED CONTACT SUPPORT CHANNEL	115x30x4 mm	M.S HDG
6.	JAW SUPPORT BRACKETS	32 X 5 FLAT	M.S HDG
7.	FIXED CONTACT JAWS (3. NOS)	32 X 5.3 FLAT	HDEC
8.	JUMPER PAD	100 X 16 FLAT	ALUMINIUM
9.	FC SPACER	-----	ALUMINIUM
10.	MOVING CONTACT	50-ODX38-ID	HDEC

BILL OF MATERIAL PER ONE SET

- NOTE:
1. ALL DIMENSIONS ARE IN MILLIMETER
 2. ALL FERROUS PARTS ARE HOT DIP GALVANIZED (85 MICRONS)
 3. ALL NON FERROUS CONTACT POINTS ARE SILVER PLATED (15 MICRONS)
 4. MOVING CONTACT ASSEMBLY SHOWN IS FOR TURN & TWIST ASSEMBLY

For Pavani Power Systems Pvt. Ltd.
(T. SESHAGIRI RAO)
Managing Director



TRANSMISSION CORPORATION OF
ANDHRA PRADESH LTD

Since the supply of terminal connectors is not in the scope of manufacturer as mentioned in drawings. The EPC contractor shall be instructed to supply the same line with /PT/CVT/Isolator/IVT /LA /Breaker requirement and capability.

REVISIONS		SCALE: 1:1	
D	C	18-05-2023	
B	A	DRAWN	
A		CHECKED	
		APPROVED	
		SHEET	02 OF 09
		DRG. NO.	PPSP-APT-MSCA-A4-02



MAIN SWITCH CONTACT ASSEMBLY
(FOR 245kV, 1600A ISOLATOR)
Pavani Power Systems Pvt. Ltd.
Plot No. 05/055/4/6, K.K. OVERSEAS SOCIETY,
PDA, DULAPALLY, QUTHUBULLAPUR MANDAL,
KODURU ROAD, HYDERABAD - 500100.
KODURU MALKAJGIR DIST. TELANGANA

NOTE: 1. Drawings Approval subject to valid type test reports, to be checked during acceptance tests.

2. FIXED CONTACT ASSEMBLY ONLY.

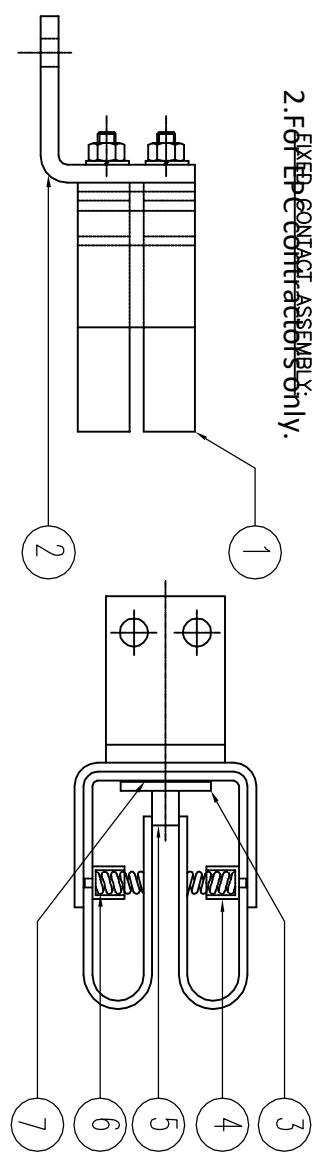

MOVING CONTACT ASSEMBLY:

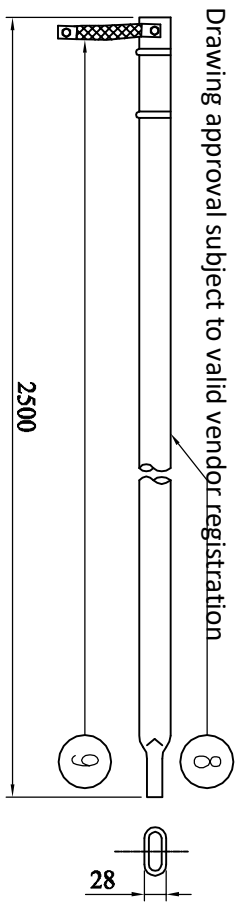

CHIEF ENGINEER/PROJECTS
APTRANSCO/VS/VIJAYAWADA

PART LIST:

1. JAWS (32 x 4 , 2 Nos. HDEC FLAT SILVER PLATED)
2. F.C. SUPPORT PLATE (8 mm THICK M.S. HDG)
3. JUMPER PLATE (75 x 12 AL. FLAT)
4. BUSH (NYLON)
5. SPACER (ALUMINIUM)
6. SPRINGS (φ2mm, STAINLESS STEEL WIRE)
7. MOVING CONTACT ASSEMBLY (38-ODX30-ID HDEC TUBE)
8. COPPER FLEXIBLE (25X4MM, 4NOS TIN PLATED)

NOTE:

1. ALL DIMENSIONS ARE IN MILLIMETER
2. ALL FERROUS PARTS ARE HOT DIP GALVANIZED (85 MICRONS)
3. ALL NON FERROUS CONTACT POINTS ARE SILVER PLATED (15 MICRONS)
4. NECESSARY BOLT, NUTS, PLAIN & SPRING WASHERS WILL BE FITTED WITH EQUIPMENT

Since the supply of terminal connectors is not in the scope of manufacturer as mentioned in the drawings. The EPC contractor shall be instructed to supply the same line with CT/PT/CVT/Isolator/IVT /LA /Breaker requirement and capability.

The part to ground clearance shall be maintained during erection as per IE rules.

For Pavani Power Systems Pvt. Ltd.
(T. SESHAGIRI RAO)
Managing Director

TRANSMISSION CORPORATION OF ANDHRA PRADESH LTD

AP TRANSCO

TITILE: BARTH SWITCH CONTACT ASSEMBLY (FOR 245KV, ISOLATOR)		SCALE: 1:1
REVISIONS	D C B A	DATE: 18-05-2023
PAVANI POWER SYSTEMS PVT.LTD. Plot No. 06/065/4/6, K.K. OVERSEAS SOCIETY, DDA, DULAPALLY, QUTHUBULLAPUR MANDAL, KODURU ROAD, HYDERABAD - 500100. MEDICAL MAJKAR DIST. TELANGANA		DRAWN
CHECKED		APPROVED
SHEET		03 OF 09
DRG. NO. PPSPT-APT-ESCA-44-03		

NOTE: 1. Drawings Approval subject to valid type test reports, to be checked during acceptance tests.

2. For EPC contractors only.

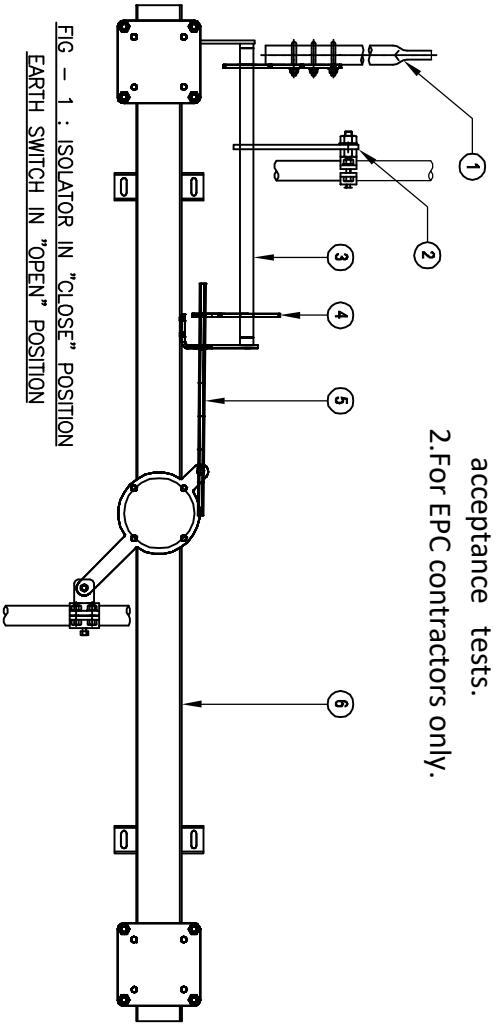

FIG - 1 : ISOLATOR IN "CLOSE" POSITION
EARTH SWITCH IN "OPEN" POSITION

Drawing approval subject to valid vendor registration

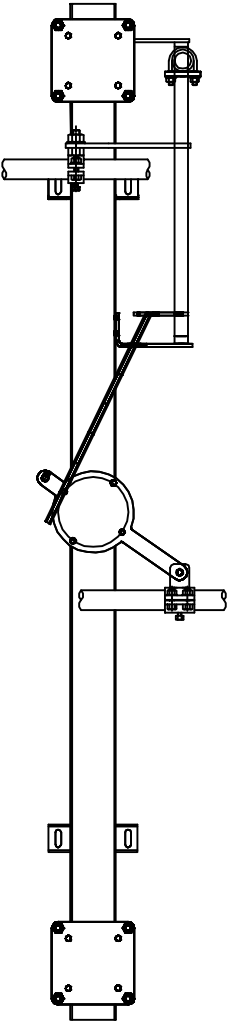

FIG - 2 : ISOLATOR IN "OPEN" POSITION
EARTH SWITCH IN "CLOSE" POSITION

CHIEF ENGINEER/PROJECTS
APTRANSCO/VS/VIJAYAWADA

Since the supply of terminal connectors is not in the scope of manufacturer as mentioned in the drawings. The EPC contractor shall be instructed to supply the same line with CT/PT/CVT/Isolator/VT /LA /Breaker requirement and compability.

CONSTRUCTION :

E.S MOVING CONTACT (1), E.S OPERATING LEVER (2) & E.S STOPPER PLATE (4) ARE CONNECTED TO THE E.S ROTATING PIPE (3). ALSO MOVES ALONG WITH THE ROTATING PIPE (3) ISOLATOR OPERATING LEVER (6) IS CONNECTED TO THE STOPPER ROD (5) WHICH IS ACT AS A MECHANICAL STOPPER.

FUNCTION :

IN FIG-1: WHEN ISOLATOR IS IN CLOSE CONDITION THEN ISOLATOR OPERATING LEVER (6) CONNECTED TO STOPPER ROD (5) MOVES THROUGH STOPPER PLATE (4) AND LOCKED WHICH WILL NOT PERMIT TO MOVE E.S ROTATING PIPE (3) EARTH SWITCH MOVING CONTACT (1) TO CLOSE POSITION.

IN FIG-2: WHEN EARTH SWITCH IS IN CLOSE CONDITION THEN ISOLATOR OPERATING LEVER (6) CONNECTED TO STOPPER ROD (5) IS LOCKED WITH STOPPER PLATE(4) WHICH WILL NOT PERMIT TO MOVE ISOLATOR OPERATING LEVER (6) TO CLOSE CLOSE POSITION.

NOTES :

1. E.S. MOVING CONTACT (38 OD X 30 ID Cu. PIPE)
2. E.S. OPERATING LEVER (50 X 10mm THIK MS FLATE HDG)
3. E.S ROTATING PIPE (25 NB MS PIPE HDG)
4. STOPPER ROD (ϕ 25mm ROD MS HDG)
5. STOPPER PATE (6mm THIK PLATE MS HDG)
7. BASE CHANNEL (145X80X5mm Thk. RECTANGLE BOX M.S HDG)

For Pavani Power Systems Pvt. Ltd.
(T. SESHAGIRI RAO)
Managing Director

AP TRANSCO

TRANSMISSION CORPORATION OF ANDHRA PRADESH LTD

REVISIONS		SCALE: 1:1	
D	C	18-05-2023	
B	A		
MECHANICAL INTERLOCK BETWEEN MAIN SWITCH AND EARTH SWITCH		DRAWN	
PAYANI POWER SYSTEMS PVT.LTD.		CHECKED	
Plot No. 06/056/4/6, K.K.OWNERS SOCIETY, KODURU ROAD, HITEERABAD - 500100.		APPROVED	
KORUPU ROAD, HITEERABAD - 500100.		SHEET	04 OF 09
KORUPU ROAD, HITEERABAD - 500100.		DRG. NO.	PPSP-APT-MIL-A4-04

NOTE: 1 Drawings Approval subject to valid type test reports, to be checked during acceptance tests.
2. For EPC contractors only.

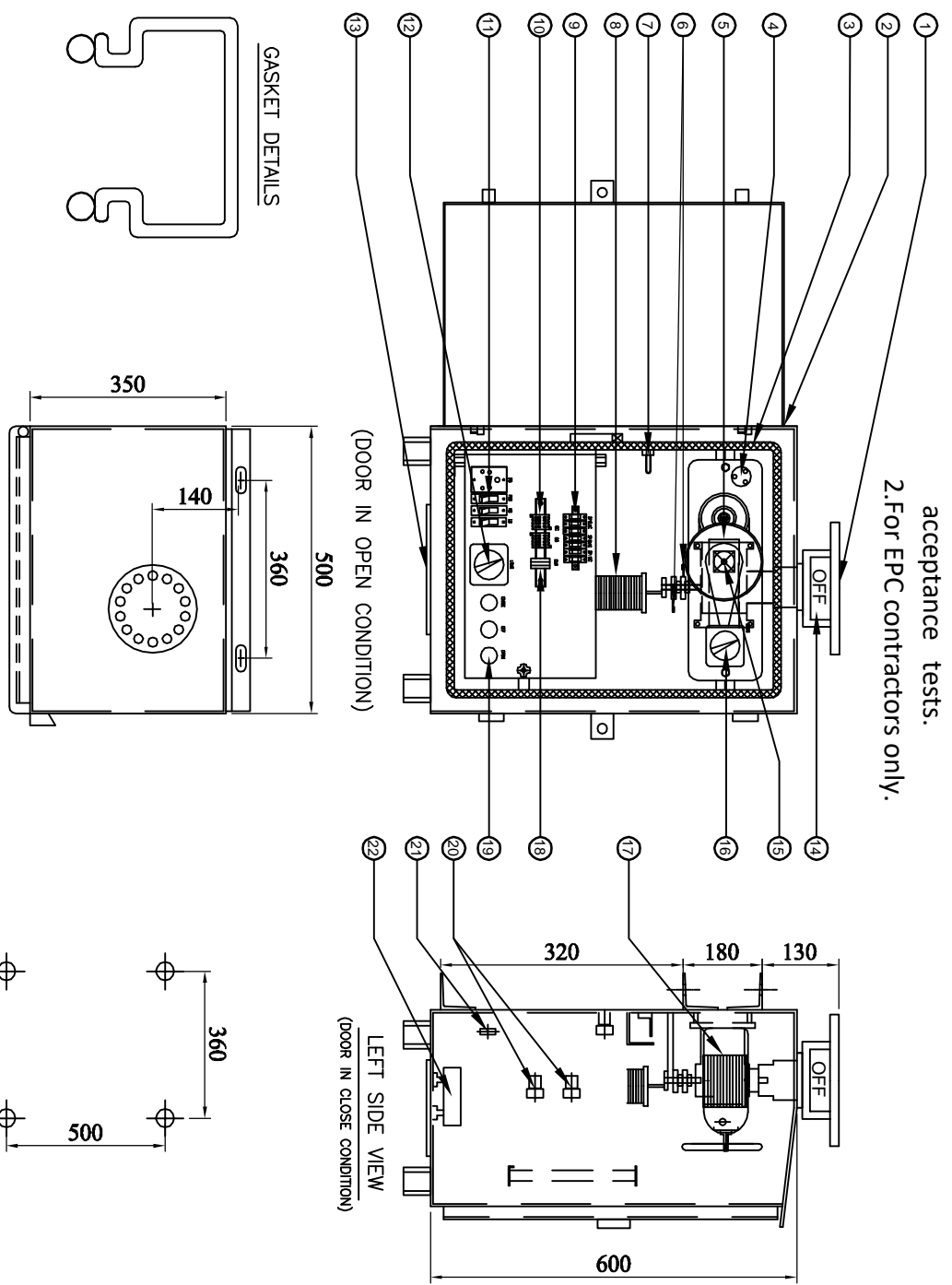

- PART LIST:-**
1. 14-HOLES FLANGE
 2. CUBICAL WITH DOOR (3mm Alu. SHEET)
 3. RUBBER GASKET (EPDM)
 4. THORMOSTAT (30°C TO 85°C)
 5. REDACTION GEAR BOX
 6. LIMIT SWITCHES (OPEN & CLOSE)
 7. CUBICLE LAMP HOLDER
 8. AUXILIARY SWITCH - 12NO+12NC
 9. 3-POLE MCB-FOR MOTOR SUPPLY
2-POLE MCB-FOR SINGLE PHASE SUPPLY
 10. CONNECTORS FOR OPEN & CLOSE
 11. POWER SOCKET/LIGHT & HEATER SWITCHES
 12. LOCAL/REMOTE/MANUAL SELECTOR SWITCH
 13. DETACHABLE TYPE CABLE GLANDS PLATE
 14. ON/OFF INDICATOR
 15. MANUAL OPERATING ARRANGEMENT
 16. INTER LOCK ROTARY SWITCH
 17. MOTOR (0.5HP 415V AC, 50 Hz)
 18. OLR-OVER LODE RELAY
 19. PUSH BUTTONS
 20. TERMINAL BLOCK
 21. EARTHING TERMINAL-2 Nos.
 22. HEATER

Drawing approval subject to valid vendor registration

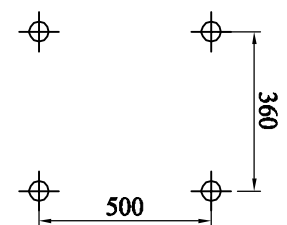

ALL DIMENSIONS ARE IN MILLIMETERS
CUBICLE WILL BE POWDER COATED WITH LIGHT GRAY SHADE NO:631 OF IS : 5
DEGREE OF PROTECTION IP: 55 AS PER IS : 13947
20% SPARE TERMINALS WILL BE PROVIDED AND SHALL BE UNIFORMLY DISRIBUTED TO ALL TERMINAL BLOCKS EQUALLY
WIRING WILL BE DONE WITH 1100V.GRADE 2.5 Sq.MM CU STRANDED P.V.C. INSULATED CONDUCTOR

CHIEF ENGINEER/PROJECTS
APTRANSCO/VS/VIJAYAWADA

WEIGHT OF THE BOX : 95Kg (APPROX.)
PPSPCL MAKE REDUCTION GEAR RATIO:20:1 MATERIALS EN8/STEEL



**TRANSMISSION CORPORATION OF
ANDHRA PRADESH LTD**

For Pavani Power Systems Pvt. Ltd.

(T. SESHAGIRI RAO)
Managing Director

REVISIONS		TTW/B:	
D	C	B	A
PAYANI POWER SYSTEMS PVT.LTD. Plot No. 06/065/4/6, K.K. OPENERS SOCIETY, DDA, DULAPALLY, QUTHUBULLAPUR MANDAL, KODURU ROAD, HYDERABAD - 500100. MICROFIL MANAGER DIST. TELANGANA		MOTOR OPERATING MECHANISM BOX (FOR 245KV ISOLATOR)	
SCALE: 1:1	DATE	DRAWN	CHECKED
	18-05-2023		
APPROVED	SHEET	DATE	DRG. NO.
	05 OF 09		PPSPCL-APT-MOM-44-05

NOTE: 1. Drawings Approval subject to valid type test reports, to be checked during acceptance tests.

2. For EPC contractors only.

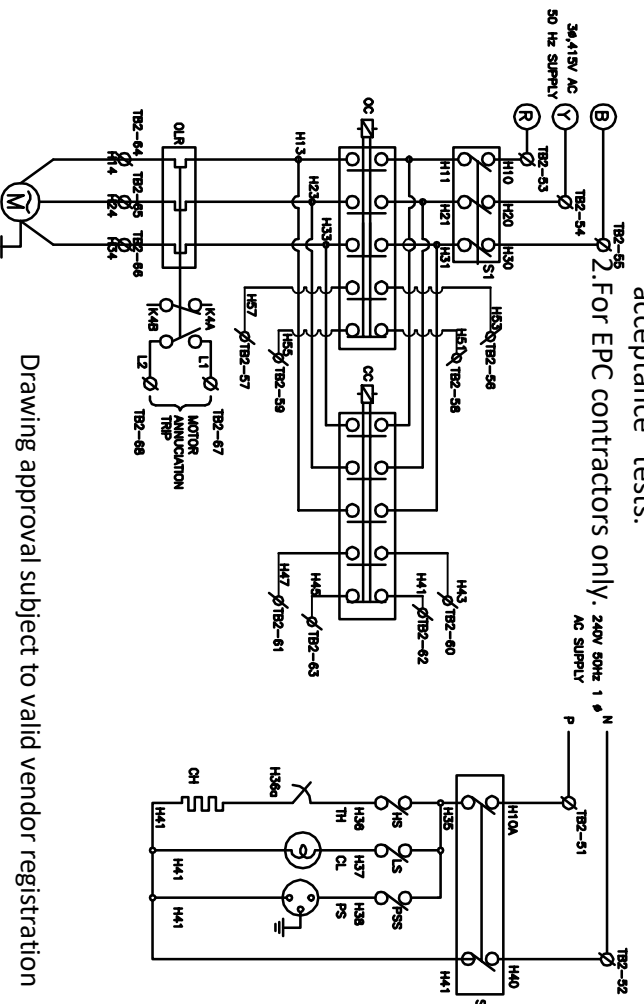

Drawing approval subject to valid vendor registration

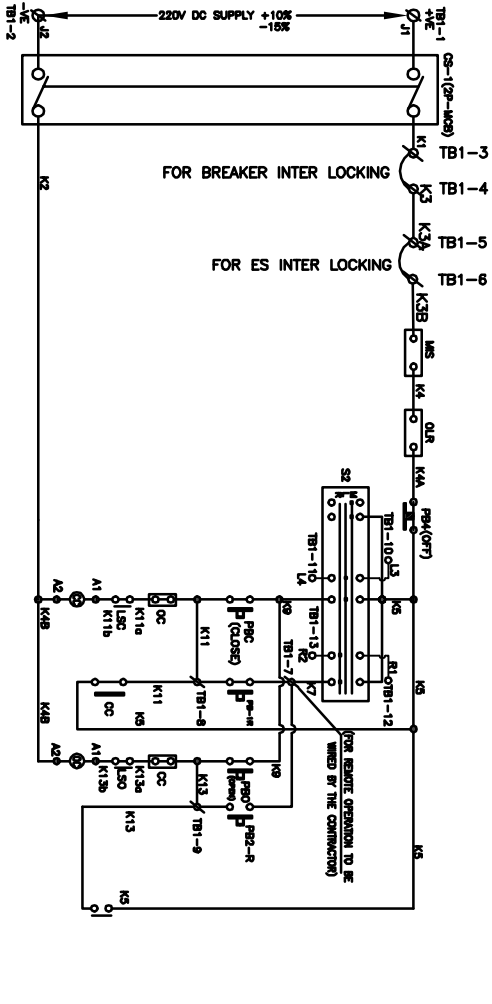

Drawing approval subject to valid vendor registration

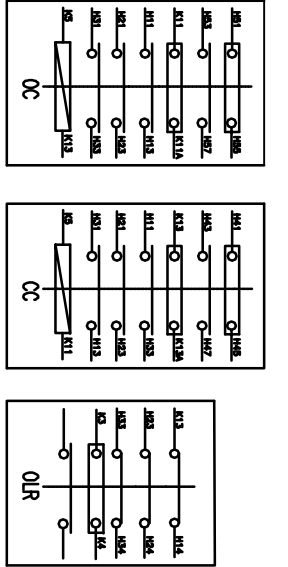

LEGEND	DESCRIPTION	MAKE
CC & OC	Close & Open contactors 220V DC, 7A	C&S/ SIEMENS/ Schneider/ ABB
CS1&CS2	Compact fluorescent lamp	PROVISION FOR LAMP.
S3	Cubic heater (80W,240V)	Grish Ego./Kontakt Pyrosensors
HS	AC 3ø 415V MCB-6A for motor	C&S/ SIEMENS/ Schneider/ ABB
MIS	AC 1ø 240V MCB-16A for AC supply	C&S/ SIEMENS/ Schneider/ ABB
LS	AC 1ø 240V, 6A one way switch for heater	Anchor/MARU
LSC	Manual interlock switch	Recom/Kaycee/Jabidajji/MANI
LSD	Lamp switch 240V, 6A one way switch	Anchor/MARU
OLR	Opens when the isolator opens, 10A 1NO+1NC	JAI BALAJI/MANI
PBC & PBO	Thermostat 30° to 85°C	Bhoskary/Mavis/Grish EGO
	Over load relay with SPP (1.0A TO 1.6A)	C&S/ SIEMENS/ Schneider/ ABB
	Close and open push buttons, 10A	Vishnov/Siemens/Schneider/C&S
	Power socket 6A, 1ø, 3pin, 230V	Anchor/CGL OR Equiv.
	Power socket 6A, 1ø, 3pin, 230V	Anchor / Maru OR Equiv.
	AC 1ø 230V one way switch	Anchor/Maru
	Local / Remote / Manual selector switch	Recom/Kaycee/Jabidajji/MANI
	Motor (0.5 HP 3ø 415V AC, 50Hz)	REMI/LHP/ELCEN/CGL
	08NO + 08 NC	Power Drives/Imax/Mani's
AUX SWITCH	Push button to OFF the circuit 10 A	Vishnov/Siemens/Schneider/C&S
	Terminal block.	Vin Mech/Elmex/Connectwell

OPERATING INSTRUCTIONS:

1. Operation is possible only when the breaker is 'OPEN' ensure this condition is satisfied
2. For manual operation of isolator follow the following steps:
 - i) Keep selector switch (s2) in manual position.
 - ii) Rotate the rotary switch provided on the top panel board, insert the handle for the manual operation.
 - iii) Rotate the handle clockwise / anticlockwise to open / close the isolator respectively
 - iv) When the manual operation is not needed restore the position of rotary switch on top panel

For Pavani Power Systems Pvt. Ltd.

(T. SESHAGIRI RAO)
Managing Director



TRANSMISSION CORPORATION OF
ANDHRA PRADESH LTD

CHIEF ENGINEER/PROJECTS

APTRANSCO/VS/VIJAYAWADA

<p>SCHEMATIC DIAGRAM FOR MOTOR / DC CONTROL PANEL</p>		<p>SCALE: 1:1</p>								
<p>REVISIONS</p> <table border="1"> <tr> <th>D</th> <th>C</th> <th>B</th> <th>A</th> </tr> <tr> <td> </td> <td> </td> <td> </td> <td> </td> </tr> </table>		D	C	B	A					<p>DATE: 18-05-2023</p>
D	C	B	A							
<p>PAYANI POWER SYSTEMS PVT.LTD. Plot No. 06/065/4/6, K.K. OVERSEAS SOCIETY, D.A. DULAPALLY, QUTHUBULLAPUR MANDAL, KOMARLA DIST., HYDERABAD - 500100. MEDICAL MAJKAR DIST., TELANGANA</p>		<p>CHECKED</p>								
<p>AP TRANSCO</p>		<p>APPROVED</p>								
<p>DRG. NO: PPSPT-APT-SD-A4-06</p>		<p>SHEET: 06 OF 09</p>								

TERMINAL BLOCK FOR DC & AC

2. For EPC contractors only.

NOTE: 1. Drawings Approval subject to valid type test reports, to be checked during acceptance tests.

AUX. SWITCH 12NO / 12NC

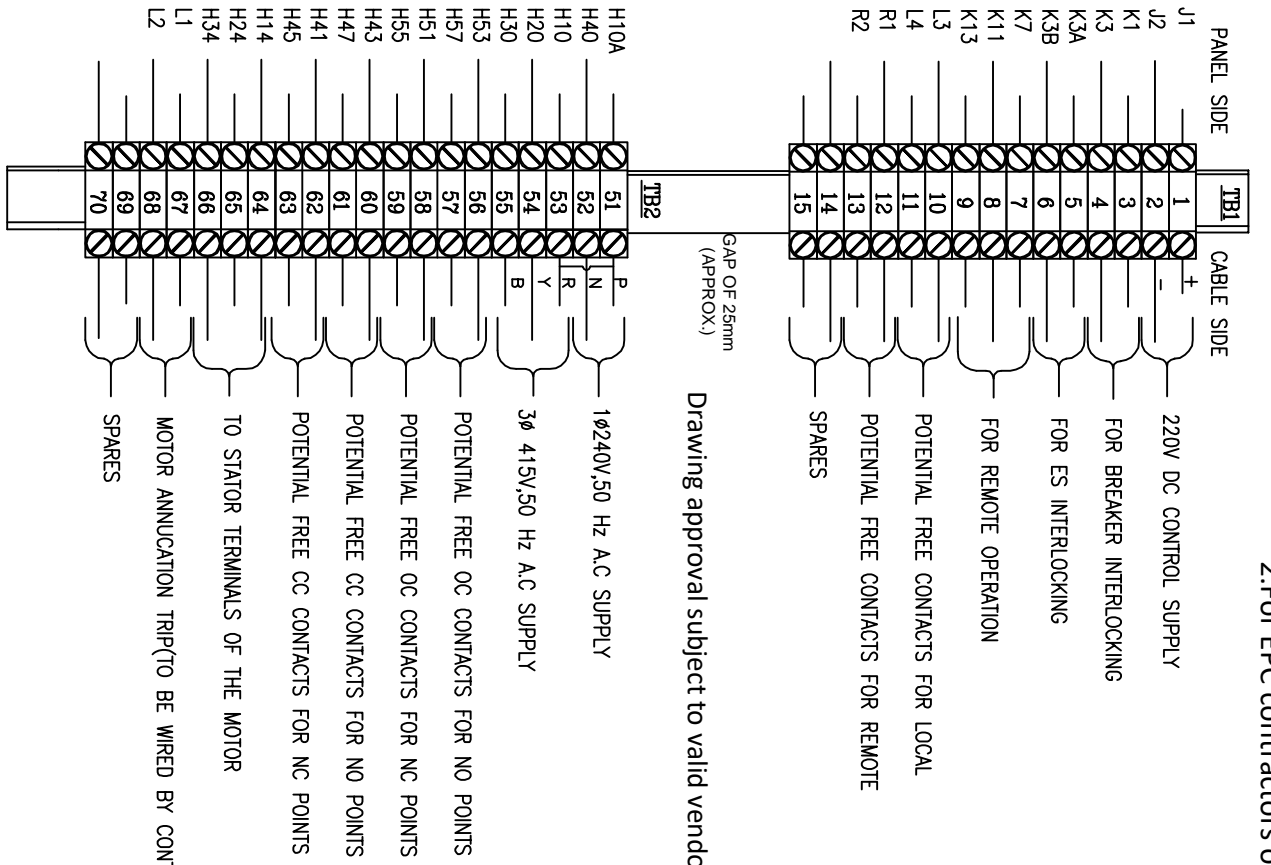

Drawing approval subject to valid vendor registration

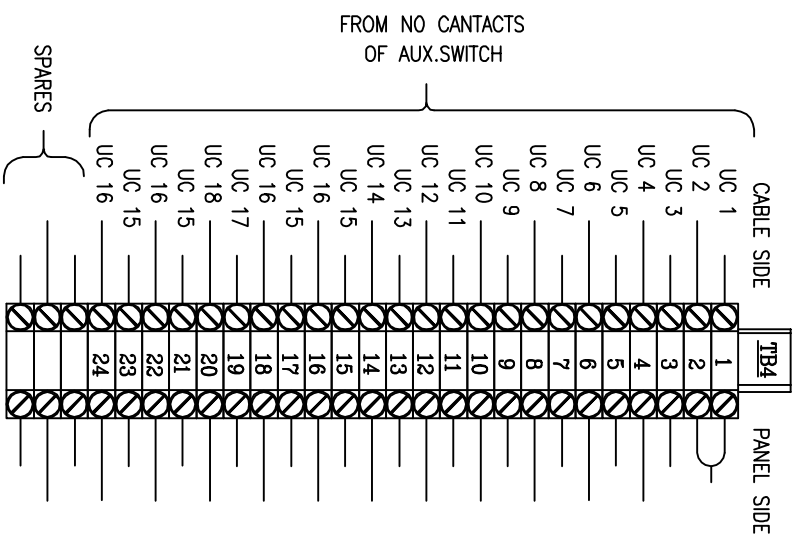
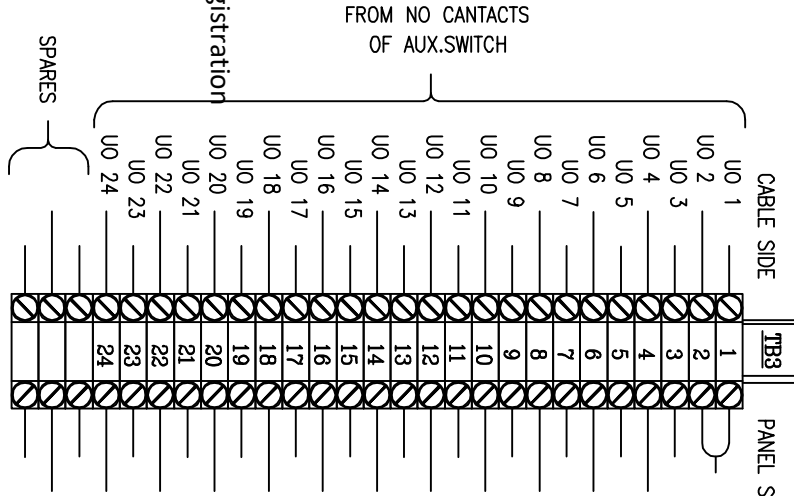

CHIEF ENGINEER/PROJECTS
APTRANSCO/VS/VIJAYAWADA

For Pavani Power Systems Pvt. Ltd.
(T. SESHAGIRI RAO)
Managing Director

Since the supply of terminal connectors is not in the scope of manufacturer as mentioned in the drawings. The EPC contractor shall be instructed to supply the same line with CT/PT/CVT/isolator/VT /LA/Breaker requirement and capability.

TRANSMISSION CORPORATION OF ANDHRA PRADESH LTD		PAVANI POWER SYSTEMS PVT.LTD.	
PLOT NO. 06/055/4/6, K.K. OVERSEAS SOCIETY, DDA, DULAPALLY, QUARTERMASTERS MANDAL, MEDICAL WALKER DIST. TELANGANA		Plot No. 06/055/4/6, K.K. OVERSEAS SOCIETY, DDA, DULAPALLY, QUARTERMASTERS MANDAL, MEDICAL WALKER DIST. TELANGANA	
TERMINAL BLOCK DETAILS		SCALE: 1:1	
REVISIONS: D C B A		DATE: 18-05-2023	
CHECKED:		DRAWN:	
APPROVED:		SHEET: 07 OF 09	
DRG. NO: PPSPT-APT-TBD-44-07		DATE:	

NOTE-1. Drawings Approval subject to valid type test reports, to be checked during acceptance tests.

2. For EPC contract only.

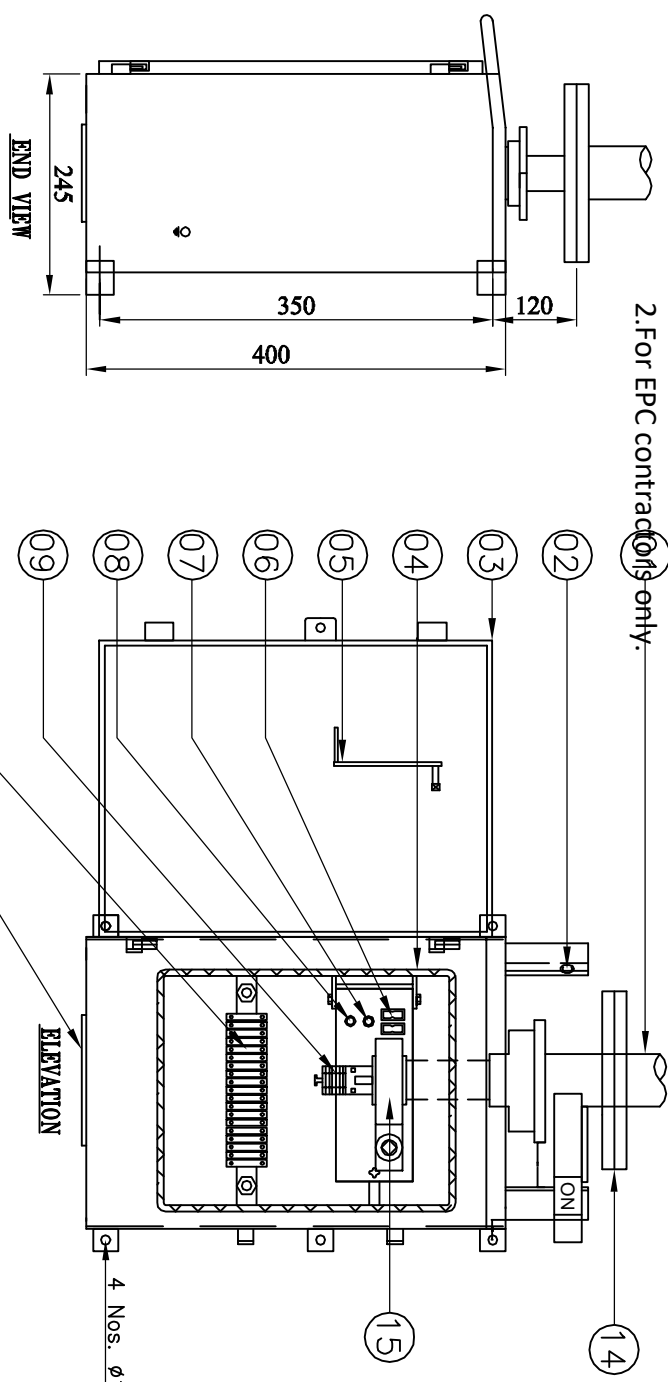

- PART LIST:-**
1. DOWN PIPE
 2. ON & OFF STOPPER
 3. CUBICAL WITH DOOR 3mm Alu. SHEET
 4. RUBBER GASKET (EPDM)
 5. OPERATING HANDLE
 6. FUSES (2A)
 7. INDICATION LAMP
 8. PUSH BUTTON
 9. AUXILIARY SWITCH 6NO + 6NC
 10. TERMINAL BLOCK(UBT-4 (VINMECH OR EQVT.))
 11. DETACHABLE TYPE CABLE GLANDS PLATE
 12. EARTHING TERMINAL-2 Nos.
 13. RAIN SHADE
 14. 12/14 HOLES FLANGE 8MM THK. (M.S HDG)
 15. REDUCTION GEAR BOX

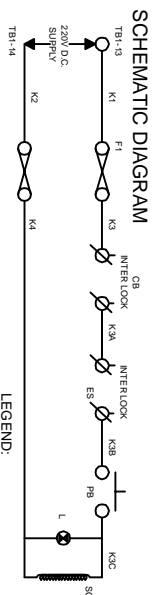

LEGEND:
 F1 F2-----FUSES (2amp Rating)
 PB-----PUSH BUTTON
 L-----INDICATION LAMP
 SC-----SOLENOID COIL

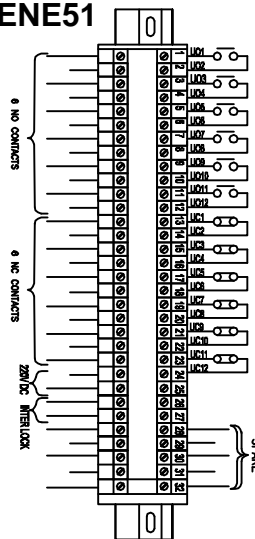

AUX. SWITCH CONTACT DETAILS FOR ISOLATOR (6 NO + 6 NC)

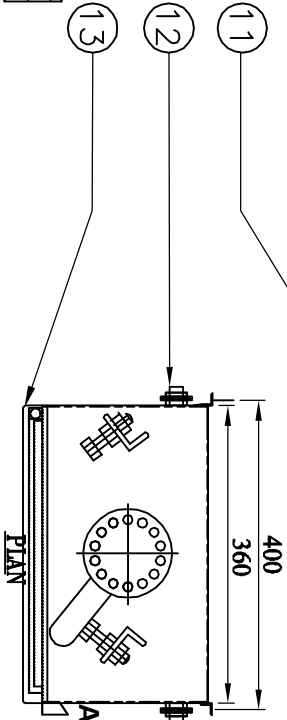

Drawing approval subject to valid vendor registration

CHIEF ENGINEER/PROJECTS
APTRANSCO/VS/VIJAYAWADA Pavani Power Systems Pvt. Ltd.

(T. SESHAGIRI RAO)
 Managing Director

7622110/2023/EFMRT-ENE51

ALL DIMENSIONS ARE IN MILLIMETERS
 CUBICLE WILL BE POWDER COATED WITH LIGHT GRAY SHADE NO:631 OF IS : 5
 DEGREE OF PROTECTION IP: 55 AS PER IS : 13947
 20% SPARE TERMINALS WILL BE PROVIDED AND SHALL BE UNIFORMLY DISRIBUTED
 TO ALL TERMINAL BLOCKS EQUALLY
 WIRING WILL BE DONE WITH 1100V.GRADE 2.5 Sq.MM CU STRANDED P.V.C.
 INSULATED CONDUCTOR
 WEIGHT OF THE BOX : 35Kg (APPROX.)
 PPSPL MAKE REDUCTION GEAR RATIO:20:1 MATERIALS EN8/STEEL

		TRANSMISSION CORPORATION OF ANDHRA PRADESH LTD	
MANUAL OPERATING MECHANISM BOX (FOR 245kV EARTH SWITCH)		SCALE: 1:1	
PAVANI POWER SYSTEMS PVT.LTD. Plot No. 05/056/4/6, K.K. OPENERS SOCIETY, DDA, DULAPALLY, QUTHUBULLAPUR MANDAL, KODURU ROAD, HYDERABAD - 500100. REGISTRATION NO. 123456789		DATE: 18-05-2023	
REVISIONS: D C B A		DRAWN:	
CHECKED:		APPROVED:	
SHEET: 08 OF 09		DRG.No: PPSPL-APT-RES-44-08	

NOTE: 1. Drawings Approval subject to valid type test reports, to be checked during acceptance tests.
2. For EPC contractors only.

CHIEF ENGINEER/PROJECTS
APTRANSCO/VS/VIJAYAWADA

 <p>MANUFACTURED & SUPPLIED BY PAVANI POWER SYSTEMS PVT.LTD. PLOT No.05/055/A/6, K.K.OWNERS SOCIETY, DULAPALLY INDUSTRIAL AREA, KOMMIPALLY POST, HYDERABAD-500100. MEDICAL MALKAJGIRI DIST. T.S.</p>	
ISOLATOR RATING NAME PLATE	
CLIENT:	TRANSMISSION CORPORATION OF A.P LTD
CUSTOMER:	---
PO.No./DATE:	---
YEAR OF MFG.	---
TYPE	DBR
VOLTAGE (kV)	245
STC kA/SEC.	50/3
CURRENT (A)	1600
SL.No.	---
FREQUENCY (Hz)	50
I.W. VOLTAGE	1050kVp
P.F.W. VOLTAGE(DRY)	460kVrms
OPERATING DRIVE	MOTOR
CONTROL VOLTAGE	220 V DC



 <p>MANUFACTURED & SUPPLIED BY PAVANI POWER SYSTEMS PVT.LTD. PLOT No.05/055/A/6, K.K.OWNERS SOCIETY, DULAPALLY INDUSTRIAL AREA, KOMMIPALLY POST, HYDERABAD-500100. MEDICAL MALKAJGIRI DIST. T.S.</p>	
ISOLATOR RATING NAME PLATE	
CLIENT:	TRANSMISSION CORPORATION OF A.P LTD
CUSTOMER:	---
PO.No./DATE:	---
YEAR OF MFG.	---
TYPE	VERTICAL
VOLTAGE (kV)	245
STC kA/SEC.	50/1
CURRENT (A)	---
SL.No.	---
FREQUENCY (Hz)	50
I.W. VOLTAGE	1050kVp
P.F.W. VOLTAGE(DRY)	460kVrms
OPERATING DRIVE	MANUAL
CONTROL VOLTAGE	220 V DC

Since the supply of terminanal connectors is not in the scope of manufacturer as mentioned in the drawings. The EPC contractor shall be instructed to supply the same line with CT/PT/CVT/Isolator/IVT /LA /Breaker requirement and campability.

For Pavani Power Systems Pvt. Ltd.
(T. SESHAGIRI RAO)
Managing Director

Drawing approval subject to valid vendor registration

Live part to ground clearance shall be maintained during erection as per IE rules.

 <p>TRANSMISSION CORPORATION OF ANDHRA PRADESH LTD</p>	
 <p>PAVANI POWER SYSTEMS PVT.LTD. PLOT No. 05/055/A/6, K.K.OWNERS SOCIETY, DULAPALLY, QUTHBULLAPUR MANDAL, KOMMIPALLY POST, HYDERABAD - 500100. MEDICAL MALKAJGIRI DIST. TELANGANA</p>	
NAME PLATE DETAILS	
(FOR 245kV, ISOLATOR AND E.S)	
SCALE: 1:1	DATE: 18-05-2023
DRAWN	CHECKED
SHEET	APPROVED
DRG.No: PPSPT-APT-NPD-44-09	09 OF 09