

NOTE:-1. Drawings approval subject to valid type test reports,  
 to be checked during acceptance tests.  
 2. For EPC contractors only.

Drawing approval subject to valid vendor registration

**Item: 245kV CT**

**Ratio: 400/1A, 1C**

**Creepage: 31mm/kV**

**Customer: APTransco, Andhra Pradesh**

**List of Standard Drawings/Documents:**

Sl. No.	Description	Drawing/ Doc No.
1	General Arrangement	APTR-05.31.245J1
2	Rating Plate	APTR_05.31.245J2
3	Terminal Box GA	APTR-05.31.245J3
4	Sectional View	APTR-05.31.245J4
5	GTP	--

Variation of Tan Delta Value from 10KV  $\mu\text{m}/\sqrt{3}$  shall be not exceed 15%.

1. Minimum 300mm plinth shall be maintained for CT/PT/CVT/ Isolators/IVT in the substation during foundation works to ensure safe live to ground clearance as per IE rules.
2. Since the supply of terminal connectors is not in the scope of manufacturers as mentioned in the drawings. The EPC contractors shall be instructed to supply the same in line with CT/PT/CVT/Isolator /IVTs requirement and capatibility.

CHIEF ENGINEER/PROJECTS  
 APTRANSCO/VS/Vijayawada

NOTE:-1. Drawings approval subject to valid type test reports, to be checked during acceptance tests.  
2. For EPC contractors only.

IF IN DOUBT ASK

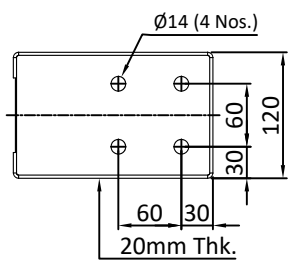
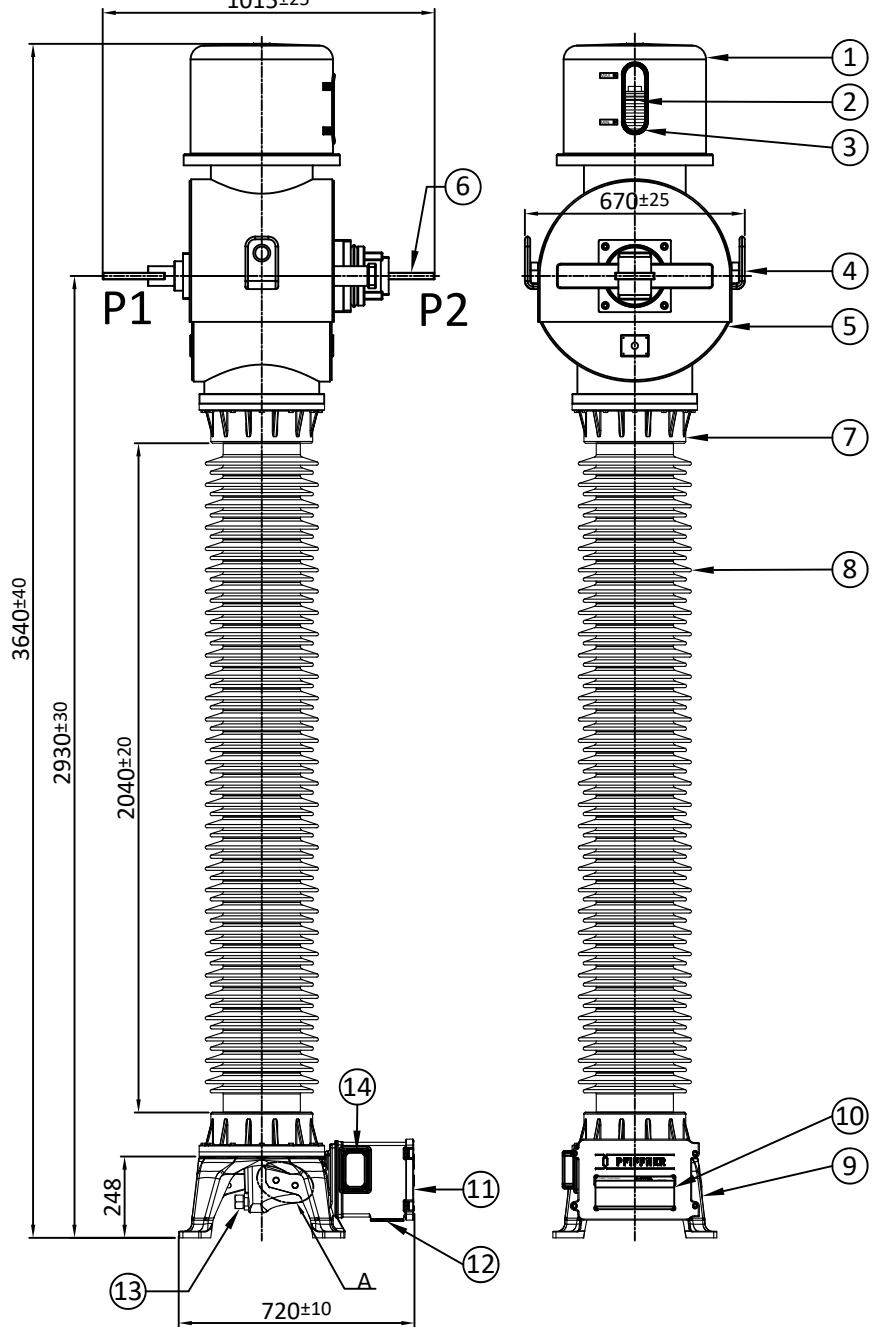

TERMINAL DETAIL

2Nos. of Ø15 Hole for Earthing Diagonally opposite

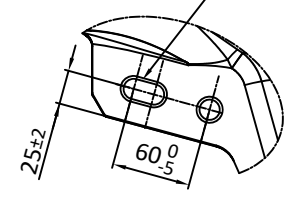

Detail 'A'

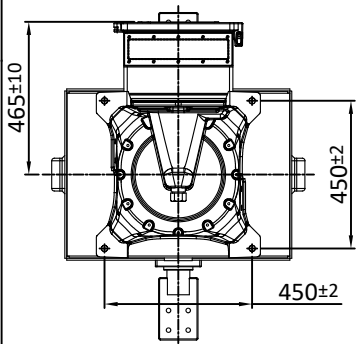

CT MOUNTING DETAIL

NO.	QTY.	DESCRIPTION	MATERIAL
01	01	BELLOWS COVER	ALUMINIUM
02	01	BELLOWS	STAINLESS STEEL
03	01	BELLOWS LEVEL INDICATOR	POLYCARBONATE
04	02	LIFTING LUG	ALUMINIUM
05	01	HOUSING	ALUMINIUM
06	02	PRIMARY TERMINAL	ALUMINIUM
07	02	INSULATOR FLANGE	ALUMINIUM
08	01	INSULATOR	PORCELAIN
09	01	BASE	ALUMINIUM
10	01	RATING PLATE	ALUMINIUM
11	01	TERMINAL BOX	ALUMINIUM
12	01	GLAND PLATE	ALUMINIUM
13	01	OIL SAMPLING VALVE	STEEL GALVANISED
14	01	TAN DELTA MEASUREMENT TERMINAL	BRASS

TOTAL WEIGHT : 620 kg ±10%  
TOTAL OIL WEIGHT : 140 kg ±10%  
CREEPAGE DISTANCE : ≥7595 mm

Drawing approval subject to valid vendor registration

Customer : TRANSMISSION CORPORATION OF ANDRA PRADESH LTD.

CHIEF ENGINEER/PROJECTS  
APTRANSCO/VS/Vijayawada

REV.NO.	DESCRIPTION	APPV'D	REV. DATE
GEN. TOL : NA	MATERIAL : NA		
WEIGHT : NA			
DRAWN : DHM	DATE : 18.04.2023	SPEC : NA	
CHK'D : CHM	DATE : 18.04.2023	FINISH : NA	
APPV'D : CHM	DATE : 18.04.2023	TITLE : GENERAL ARRANGEMENT	
		APTR-05.31.245J1	
		SHEET 1 OF 1	
		REV. NO. : 00	

**PIFFNER**  
Instrument Transformers Pvt.Ltd.  
NASHIK, INDIA

TITLE : GENERAL ARRANGEMENT  
245KV CT  
APTR-05.31.245J1  
SHEET 1 OF 1  
REV. NO. : 00

This document must not be copied without our written permission and the content and nor be used for any unauthorised purpose. Contravention will be prosecuted. © PFIFFNER

Variation of Tan Delta Value from 10KV um/sqrt 3 shall be not exceed 15%.

IF IN DOUBT ASK

<b>PFIFFNER</b> Instrument Transformers Pvt.Ltd. NASHIK, INDIA		<b>CURRENT TRANSFORMER</b> MADE IN INDIA	
CUSTOMER : TRANSMISSION CORPORATION OF ANDRA PRADESH LTD.		PO No. : -----	
YEAR : ----	SPECIFICATION IS 16227, IEC 61869	H.S.V. 245kv	SERIAL NO. -----
TYPE JOF 245 W	STC. 40 kA for 1S	INSULATION LEVEL 460 kV/1050 kVp	RATED PRIMARY CURRENT 400 A
FREQUENCY 50 Hz	Idyn 100 kAp	TOTAL CREEPAGE DISTANCE ≥ 7595mm	RATED CONT. THERMAL CURRENT 480 A
CORE NO.	1		
RATIO	400/1		
PRI. TERMINAL	P1-P2		
SEC. TERMINAL	1S1-1S2 (SHORT 1S2-A)		
VA	5		
CLASS	0.2S		
ISF	≤5		
Vk (V) min.	--		
max I <sub>exc</sub> at Vk (mA)	--		
Rct (Ω)	--		
Total weight	620 ±10% kg	Oil weight	140 ±10% kg

94±0.5

100

Ø1.7 (04 Nos.)

CHIEF ENGINEER/PROJECTS  
APTRANSCO/VS/Vijayawada

Variation of Tan Delta Value from 10KV um/sqrt 3 shall be not exceed 15%.

<b>PFIFFNER</b> Instrument Transformers Pvt.Ltd. NASHIK, INDIA		<b>CURRENT TRANSFORMER</b> MADE IN INDIA	
		SERIAL NO.	-----
		YEAR	----

CAUTION : - Short all sec. terminals when not in use or before disconnecting burdens.  
Also check bellows position.  
- Capacitance & Tan delta terminal 'T<sub>δ</sub>' shall always be connected to earth & disconnect only for measurement.

98±0.5

105

Ø1.7 (04 Nos.)

NOTE:-1. Drawings approval subject to valid type test reports, to be checked during acceptance tests.  
2. For EPC contractors only.

Drawing approval subject to valid vendor registration

Customer : TRANSMISSION CORPORATION OF ANDRA PRADESH LTD.

01					
REV.NO.	DESCRIPTION			APPV'D	REV. DATE
GEN. TOL. : NA	MATERIAL : 1mm thick Aluminium metal photo				ALL DIMENSION ARE IN MM. UNLESS OTHRWISE SPECIFIED.
WEIGHT : NA	SPEC : NA				
DRAWN	DHM		18.04.2023	FINISH : NA	SCALE : N.T.S.
CHK'D	CHM		18.04.2023		SHEET SIZE : A3
APPV'D	CHM		18.04.2023		DWG NO.
<b>PFIFFNER</b> Instrument Transformers Pvt.Ltd. NASHIK, INDIA				TITLE : RATING PLATE 245 kV CT	
				APTR_05.31.245J2	
				SHEET 1 OF 1   REV. NO. : 00	

This document must not be copied without our written permission and the content and nor be used for any unauthorised purpose. Contravention will be prosecuted. © PFIFFNER

NOTE:-1. Drawings approval subject to valid type test reports,

to be checked during acceptance tests.

2. For EPC contractors only.

IF IN DOUBT ASK

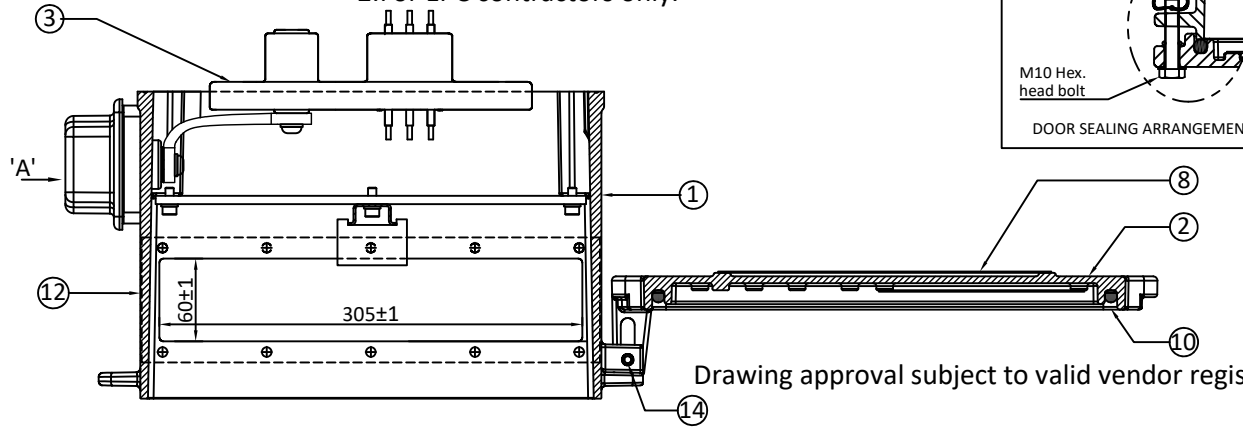

Drawing approval subject to valid vendor registration

SR.NO.	DESCRIPTION	QTY.	MATERIAL
1	TERMINAL BOX	1	ALUMINIUM
2	TERMINAL BOX DOOR	1	ALUMINIUM
3	SECONDARY LEAD OUT	1	EPOXY
4	STUD TYPE TERMINAL BLOCK (KBT M4 )	3+2 SPARE	MAKE - ELMEX
5	TERMINAL CARRIER RAIL	2	STEEL
6	GLAND PLATE	1	ALUMINIUM
7	GLAND PLATE GASKET	1	NEOPRENE RUBBER
8	RATING PLATE	1	ALUMINIUM
9	SCHEMATIC DIAGRAM PLATE	1	ALUMINIUM
10	DOOR GASKET	1	EPDM RUBBER
11	DOOR EARTHING CABLE	1	PVC INSULATED COPPER CABLE
12	WARNING STICKER	1	ALUMINIUM
13	TAN DELTA (T <sub>δ</sub> ) MEASUREMENT TERMINAL	1	BRASS
14	HINGES	2	S.S. TENSION PIN
15	TAN DELTA EARTH LINK	1	COPPER (NICKEL PLATED)

Variation of Tan Delta Value from 10KV um/sqrt 3 shall be not exceed 15%.

DEGREE OF PROTECTION : IP 55

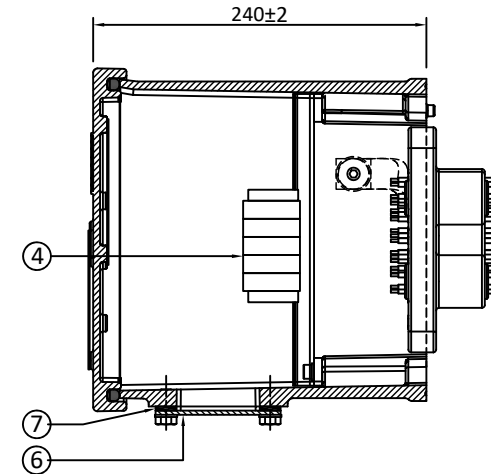
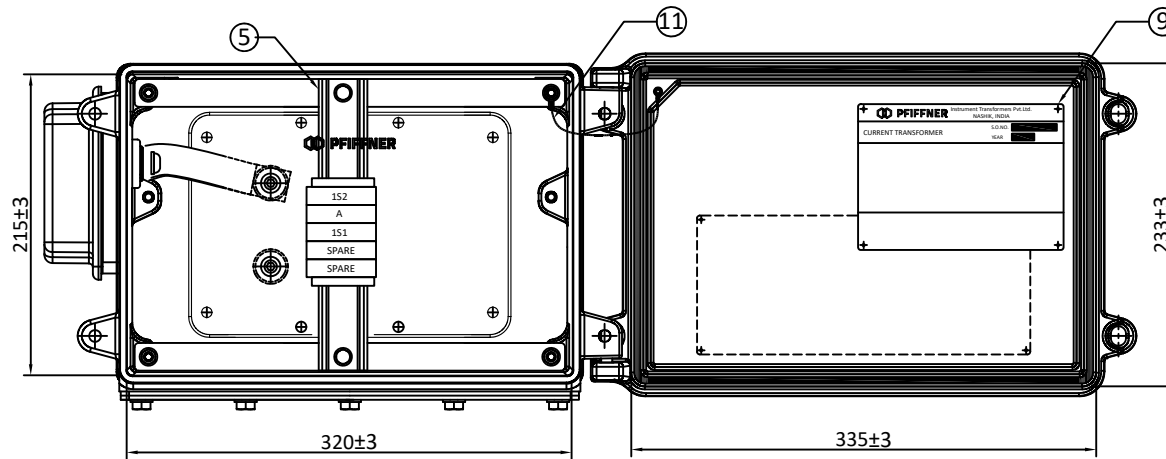

Customer : TRANSMISSION CORPORATION OF ANDRA PRADESH LTD.

This document must not be copied without our written permission and the content and nor be used for any unauthorised purpose. Contravention will be prosecuted. PFIFFNER

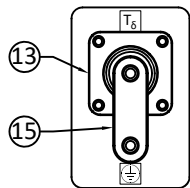

Detail 'A'

**WARNING**  
"T<sub>δ</sub>" TERMINAL - DO NOT OPEN WHEN IN SERVICE

Item : 12

CHIEF ENGINEER/PROJECTS  
APTRANSCO/VS/Vijayawada

REV.NO.	DESCRIPTION	APPV'D	REV. DATE
01			
GEN. TOL : NA		MATERIAL : NA	
WEIGHT : NA		SPEC : NA	
DRAWN	DHM	18.04.2023	FINISH : NA
CHK'D	CHM	18.04.2023	SCALE : N.T.S.
APPV'D	CHM	18.04.2023	SHEET SIZE : A3
			DWG NO.
TITLE : TERMINAL BOX GA 245KV CT			APTR-05.31.245J3
SHEET 1 OF 1			REV. NO. : 00

NOTE:-1.Drawings approval subject to valid type test reports,  
to be checked during acceptance tests.  
2.For EPC contractors only.

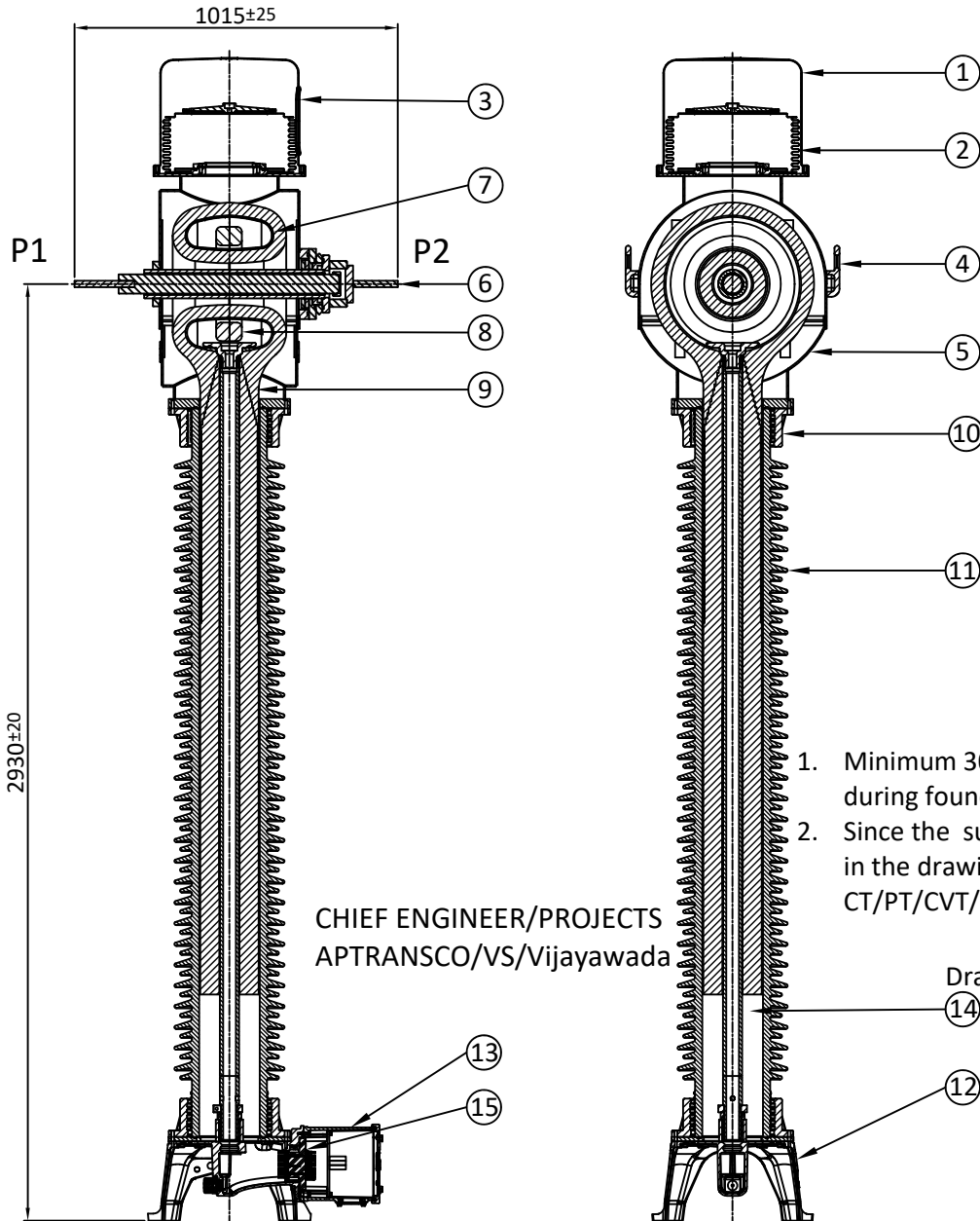

NO.	QTY.	DESCRIPTION	MATERIAL
01	01	BELLOWS COVER	ALUMINIUM
02	01	BELLOWS	STAINLESS STEEL
03	01	BELLOW LEVEL INDICATOR	POLYCARBONATE
04	02	LIFTING LUG	ALUMINIUM
05	01	HOUSING	ALUMINIUM
06	02	PRIMARY TERMINAL	ALUMINIUM
07	01	CORE BOX	ALUMINIUM
08	01	SECONDARY CORES	CRGO & NANO
09	01	ACTIVE PART	OIL IMPREGNATED PAPER
10	02	INSULATOR FLANGE	ALUMINIUM
11	01	INSULATOR	PORCELAIN
12	01	BASE	ALUMINIUM
13	01	TERMINAL BOX	ALUMINIUM
14	--	INSULATING OIL	EHV Grade - MINERAL OIL
15	01	SECONDARY LEADOUT	EPOXY

Notes:

- Insulating oil shall be EHV Grade as per IS 335, IEC 296
- Core : CRGO Si-Fe/ Equivalent high permeability material, MU- Metal, NANO - crystalline
- Secondary winding - Enamelled copper

1. Minimum 300mm plinth shall be maintained for CT/PT/CVT/ Isolators/IVT in the substation during foundation works to ensure safe live to ground clearance as per IE rules.
2. Since the supply of terminal connectors is not in the scope of manufacturers as mentioned in the drawings. The EPC contractors shall be instructed to supply the same in line with CT/PT/CVT/Isolator /IVTs requirement and capatibility.

CHIEF ENGINEER/PROJECTS  
APTRANSCO/VS/Vijayawada

Drawing approval subject to valid vendor registration

Variation of Tan Delta Value from 10KV um/sqrt 3 shall be not exceed 15%.

This document must not be copied without our written permission and the content and nor be used for any unauthorised purpose. contravention will be prosecuted. © PFIFFNER

REV.NO.	DESCRIPTION			APPV'D	REV. DATE
GEN. TOL : NA	MATERIAL : NA				ALL DIMENSION ARE IN MM. UNLESS OTHRWISE SPECIFIED.
WEIGHT : NA	SPEC : NA				
DRAWN	NAME	SIGN	DATE	FINISH : NA	SCALE : N.T.S.
CHK'D	CHM		18.04.2023		SHEET SIZE : A3
APPV'D	CHM		18.04.2023		DRG NO.
<b>PFIFFNER</b> Instrument Transformers Pvt.Ltd. NASHIK, INDIA				TITLE : SECTIONAL VIEW 245KV CT	
				SHEET 1 OF 1   REV. NO. : 00	

**Annexure-A**  
**GUARANTEED TECHNICAL PARTICULARS FOR CURRENT TRANSFORMERS**

**JOF 245 W OUTDOOR CURRENT TRANSFORMERS**  
**(245kV 400A CT, 1 Core 31mm Creepage)**

Sl.No	Particulars	Description
1	Type of tank/Installation Dead/Live Tank Type	Live Tank, Single Phase, Oil Filled, Outdoor Type
2	Type of mounting	Pedestal Mounting
3	Manufacturer's Name and address and Country of Manufacture	PFIFFNER Instrument Transformers Pvt Limited, Gat No. 176, 178/2, Sarul, Nashik 422010, Maharashtra, INDIA
4	Whether Conforming to IEC 61869 Standard	Yes, IEC 61869-1&2
5 a)	Primary and Secondary winding made out of	Primary- Aluminium alloy of C/S section area 1250mm <sup>2</sup> Secondary - Copper alloy of C/S section area 1.168mm <sup>2</sup>
b)	Material used for providing Primary Terminals	Aluminium
c)	Material used for providing secondary Terminals	Copper Alloy
d)	Whether Primary is Rigid Bar type in case of live tank	Yes, Rigid Bar type
6	Rated primary voltage (kV rms)	220 kV
7	Rated highest voltage (kV rms)	245 kV
8	Rated frequency (Hz)	50 Hz
9	Rated primary current (A)	400A
10	Rated secondary current (A)	1A
11	Ratio taps (on secondary side only)	On Secondary Only
12	Type of insulation	Class A
13	Seismic acceleration (g)	0.3g
14	RIV at 1.1 x Rated voltage (mv)	< 500 Micro Volts
15	Tank material and Tank coating	Aluminium Tank with Natural Finish
16	Hardware exposed to atmosphere	Stainless Steel
17	Bolts, Nuts and Washers	Stainless Steel
18	Porcelain housing and it make (Single piece only)	IEC/Modern/Ravikiran
19	Sealing (Nitrogen gas cushion/Metal Bellow)	Stainless Steel Bellows
20	Instrument security factor	≤ 5 (For Metering core )
21	Whether Tan Delta test tap provided	Yes
22	Whether secondary terminal plate is of moulded epoxy resin type	Yes (Epoxy Monoblock)
23	Whether primary terminal	Not Applicable

CHIEF ENGINEER/PROJECTS  
 APTRANSCO/VS/Vijayawada

Variation of Tan Delta Value from 10KV um/sqrt 3 shall be not exceed 15%.

PFIFFNER INSTRUMENT TRANSFORMERS PRIVATE LIMITED | CIN: U31909MH2018FTC318024

G.NO.176, 178/2, SARUL, NASHIK- 422010, MH, INDIA | +912532978227 | [contact@piffner.in](mailto:contact@piffner.in) | [www.piffner.in](http://www.piffner.in)

Drawing approval subject to valid vendor registration

Sl.No	Particulars	Description
	bushings are of molded Epoxy cast resin/Glass fiber reinforced Polymer	
24	Whether all seals are of "O" ring type	Yes, "O" Rings
25	Whether all "O" Rings are fixed in machined grooves with adequate space for compression'	Yes
26	Whether the main hollow insulator has the flanges cemented at both ends	Yes
27	Whether "O" Rings are of Nitrile butyl rubber or Viton	Yes (Viton)
28	Whether the Short circuit Ampere turns of the CT being supplied is same as type tested CTs	Yes
29	Tan Delta	< 0.5%
30	Whether ratio selection is achieved only in secondary	Yes
31	Whether ratio selection is achieved only in secondary	Yes
32	Whether Non return drain valve for oil sampling is arranged for 132kV and above CT/IVT	Yes
33	Acceptable limit of temperature	As per IS/IEC
34	Partial Discharge Level	< 5pC at 1.2 x Um /√3, < 10pC at Um (where Um is highest system voltage)
35	Rated short time withstand current for 1 sec. duration (kA rms)	40 kA
36	Rated dynamic withstand current (kAp)	100
37	Rated continuous thermal current (pu) where pu = rated current	Rated Extended Primary Current 120%
38	1.2/50 micro second impulse withstand voltage (kVp)	1050 kVp
39	One minute power frequency withstand voltage (kV rms) of primary winding (Dry)	460 kV rms
40	One minute power frequency withstand voltage of secondary winding (kV rms)	3 kV CHIEF ENGINEER/PROJECTS APTRANSCO/VS/Vijayawada

Variation of Tan Delta Value from 10KV um/sqrt 3 shall be not exceed 15%.

PIFFNER INSTRUMENT TRANSFORMERS PRIVATE LIMITED | CIN: U31909MH2018FTC318024

G.NO.176, 178/2, SARUL, NASHIK- 422010, MH, INDIA | +912532978227 | [contact@piffner.in](mailto:contact@piffner.in) | [www.piffner.in](http://www.piffner.in)

Drawing approval subject to valid vendor registration

Sl.No	Particulars	Description
41 a)	Minimum total Creepage distance of insulator bushing (mm)	31mm/kV Porcelain Insulator / 7595 mm
b)	Protected Creepage of distance of bushing (mm)	Not Applicable
42	Details of Cores	Core 1
i)	Current Ratios A/A	400/1A
ii)	Output burden (VA)	5
iii)	Class of accuracy	0.2S
iv)	ISF	5
v)	Min. knee point voltage (kpv) in volts	NA
vi)	Secondary resistance corrected to 75 deg.C in ohms	NA
vii)	Max. Exciting current (mA) at Vk - 100% of knee point voltage	NA
viii)	Application	Metering
43	Weight of oil (Kg.)	140kg ± 10% (approx.)
44	Approximate weight of copper used (Kg)	NA
45	Approximate weight of Steel used (Kg)	NA
46	Total Weight (Kg.)	620 ± 10% (approx.)
47	Mounting details	450mm x 450mm (Refer GA Drawing)
48	Overall dimensions	Please Refer Attached GA Drawing
49	Characteristics (whether graphs enclosed):	No
a)	Ratio and phase angle curves	No
b)	Magnetization curves	No CHIEF ENGINEER/PROJECTS
c)	Ratio correction factor curves	No APTRANSCO/VIS/Vijayawada
50	Core	
a)	Area of cross section (sq.cm.)	As per Standard Design Practice
b)	Flux density at rated primary current and rated burden	As Per Standard Design Practice
c)	Grade	Nano-crystalline core for Metering CRGO steel or other equivalent alloys for Protection Cores
51	Cantilever strength (kG)	400 KG

Variation of Tan Delta Value from 10KV um/sqrt 3 shall be not exceed 15%.

1. Minimum 300mm plinth shall be maintained for CT/PT/CVT/ Isolators/IVT in the substation during foundation works to ensure safe live to ground clearance as per IE rules.
2. Since the supply of terminal connectors is not in the scope of manufacturers as mentioned in the drawings. The EPC contractors shall be instructed to supply the same in line with CT/PT/CVT/Isolator/IVTs requirement and capatibility.