

Variation of Tan Delta Value from 10KV um/sqrt 3 shall be not exceed 15%.

**Item: 245kV CT**

**Ratio:** 500-300/1-1-1-1-1A (5C) Drawing approval subject to valid vendor registration

**Creepage:** 31mm/kV

**Customer:** APTransco, Andhra Pradesh

**List of Standard Drawings/Documents:**

| Sl. No. | Description         | Drawing/ Doc No.           |
|---------|---------------------|----------------------------|
| 1       | General Arrangement | APTR-03.31.245J1           |
| 2       | Rating Plate        | APTR_03.31.245J2_REV No.01 |
| 3       | Terminal Box GA     | APTR-03.31.245J3_REV No.01 |
| 4       | Sectional View      | APTR-03.31.245J4           |
| 5       | GTP                 | --                         |

1. Minimum 300mm plinth shall be maintained for CT/PT/CVT/ Isolators/IVT in the substation during foundation works to ensure safe live to ground clearance as per IE rules.
2. Since the supply of terminal connectors is not in the scope of manufacturers as mentioned in the drawings. The EPC contractors shall be instructed to supply the same in line with CT/PT/CVT/Isolator /IVTs requirement and capatibility.

CHIEF ENGINEER/PROJECTS  
APTRANSCO/VS/Vijayawada

NOTE:-1. Drawings approval subject to valid type test reports,

to be checked during acceptance tests.

2. For EPC contractors only.

IF IN DOUBT ASK

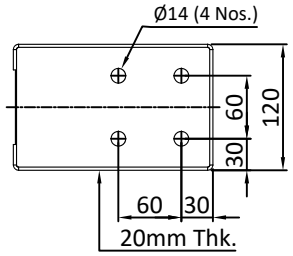
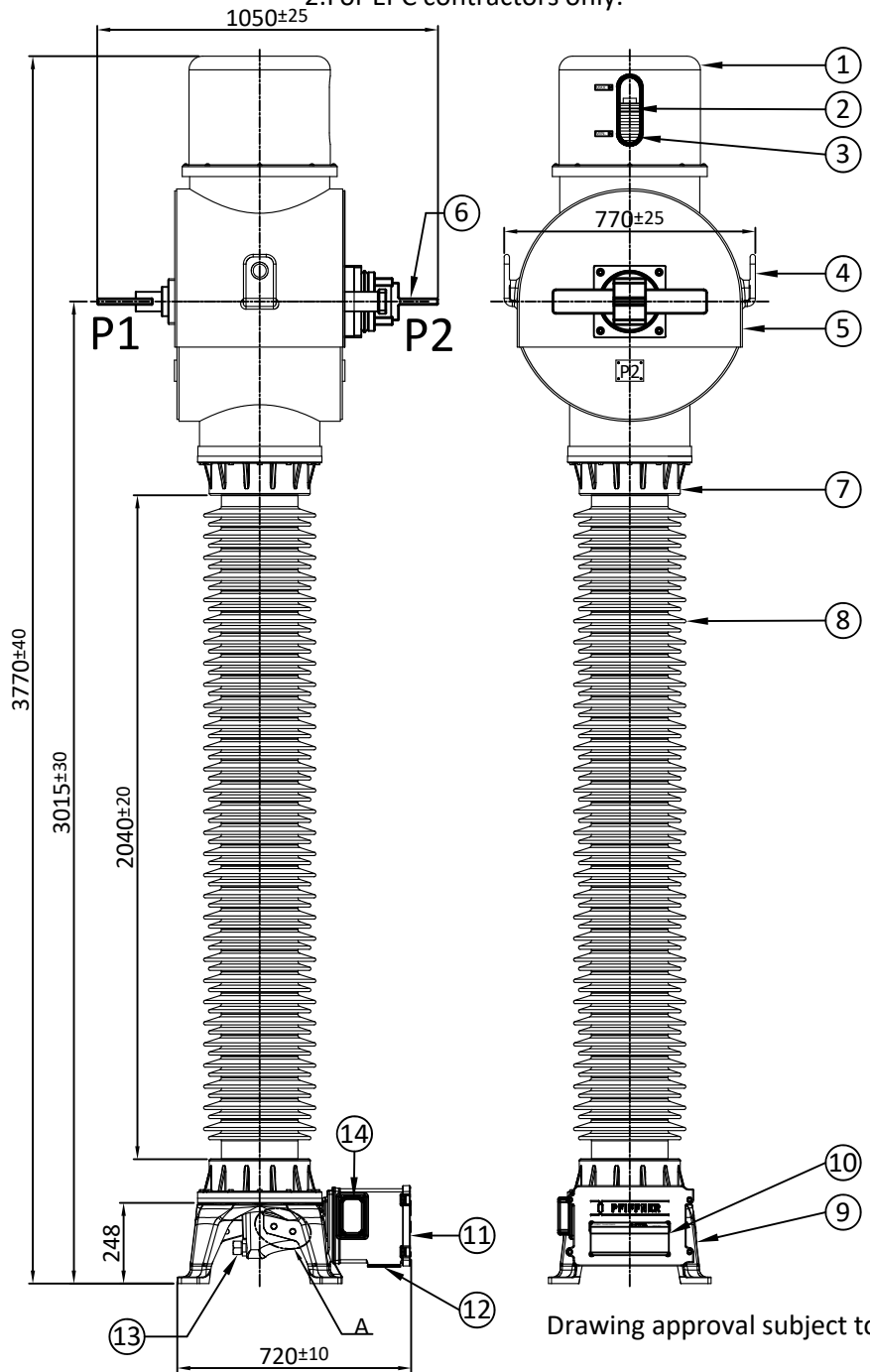

TERMINAL DETAIL

2Nos. of Ø15 Hole for Earthing Diagonally opposite

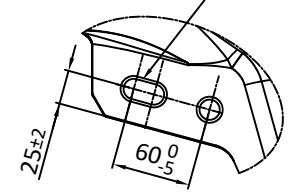

Detail 'A'

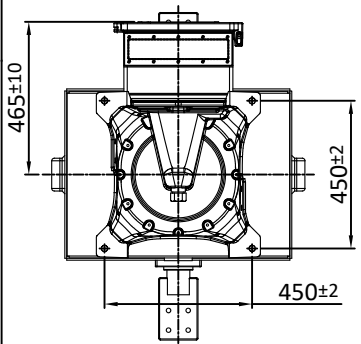

CT MOUNTING DETAIL

| NO. | QTY. | DESCRIPTION                    | MATERIAL         |
|-----|------|--------------------------------|------------------|
| 01  | 01   | BELLOWS COVER                  | ALUMINIUM        |
| 02  | 01   | BELLOWS                        | STAINLESS STEEL  |
| 03  | 01   | BELLOWS LEVEL INDICATOR        | POLYCARBONATE    |
| 04  | 02   | LIFTING LUG                    | ALUMINIUM        |
| 05  | 01   | HOUSING                        | ALUMINIUM        |
| 06  | 02   | PRIMARY TERMINAL               | ALUMINIUM        |
| 07  | 02   | INSULATOR FLANGE               | ALUMINIUM        |
| 08  | 01   | INSULATOR                      | PORCELAIN        |
| 09  | 01   | BASE                           | ALUMINIUM        |
| 10  | 01   | RATING PLATE                   | ALUMINIUM        |
| 11  | 01   | TERMINAL BOX                   | ALUMINIUM        |
| 12  | 01   | GLAND PLATE                    | ALUMINIUM        |
| 13  | 01   | OIL SAMPLING VALVE             | STEEL GALVANISED |
| 14  | 01   | TAN DELTA MEASUREMENT TERMINAL | BRASS            |

TOTAL WEIGHT : 720 kg ±10%  
 TOTAL OIL WEIGHT : 180 kg ±10%  
 CREEPAGE DISTANCE : ≥7595 mm

CHIEF ENGINEER/PROJECTS  
 APTRANSCO/VS/Vijayawada

Customer : TRANSMISSION CORPORATION OF ANDRA PRADESH LTD.

| REV.NO.   | DESCRIPTION     | APPV'D  | REV. DATE |
|---|-----------------|---|-----------|
| GEN. TOL : NA   | MATERIAL : NA   |   |           |
| WEIGHT : NA   |                 |   |           |
| DRAWN M.D.  | DATE 06.03.2023 | ALL DIMENSION ARE IN MM. UNLESS OTHRWISE SPECIFIED. |           |
| CHK'D M.C.  | DATE 06.03.2023 | SCALE : N.T.S.                                      |           |
| APPV'D R.P.   | DATE 06.03.2023 | SHEET SIZE : A3                                     |           |
| PFIFFNER<br>Instrument Transformers Pvt.Ltd.<br>NASHIK, INDIA |                 | TITLE :<br>GENERAL ARRANGEMENT<br>245KV CT          |           |
|   |                 | DWG NO.<br>APTR-03.31.245J1                         |           |
|   |                 | SHEET 1 OF 1    REV. NO. : 00                       |           |

Drawing approval subject to valid vendor registration

Variation of Tan Delta Value from 10KV um/sqrt 3 shall be not exceed 15%.

This document must not be copied without our written permission and the content and nor be used for any unauthorised purpose. Contravention will be prosecuted. PFIFFNER

NOTE:-1. Drawings approval subject to valid type test reports,

to be checked during acceptance tests.

2. For EPC contractors only.

IF IN DOUBT ASK



**PFIFFNER** Instrument Transformers Pvt.Ltd.  
NASHIK, INDIA

**CURRENT TRANSFORMER**  
MADE IN INDIA

|   |           |               |                     |                         |                 |                       |                             |           |                       |                       |
|---|-----------|---------------|---------------------|-------------------------|-----------------|-----------------------|-----------------------------|-----------|-----------------------|-----------------------|
| CUSTOMER : TRANSMISSION CORPORATION OF ANDRA PRADESH LTD. |           |               |                     | PO No. : -----          |                 |                       |                             |           |                       |                       |
| YEAR  | ----      | SPECIFICATION | IS 16227, IEC 61869 |                         | H.S.V.          | 245kv                 | SERIAL NO.                  | -----     |                       |                       |
| TYPE  | JOF 245 W | STC.          | 40 ka for 1S        | INSULATION LEVEL        | 460 kv/1050 kvp | RATED PRIMARY CURRENT |                             | 500 A     |                       |                       |
| FREQUENCY   | 50 Hz     | Idyn          | 100 kAp             | TOTAL CREEPAGE DISTANCE | ≥ 7595 mm       |                       | RATED CONT. THERMAL CURRENT |           | 600 A                 |                       |
| CORE NO.  | 1         |               | 2                   |                         | 3               |                       | 4                           |           | 5                     |                       |
| RATIO   | 300/1     | 500/1         | 300/1               | 500/1                   | 300/1           | 500/1                 | 300/1                       | 500/1     | 300/1                 | 500/1                 |
| PRI. TERMINAL   | P1-P2     | P1-P2         | P1-P2               | P1-P2                   | P1-P2           | P1-P2                 | P1-P2                       | P1-P2     | P1-P2                 | P1-P2                 |
| SEC. TERMINAL   | 1S1-1S2   | 1S1-1S3       | 2S1-2S2             | 2S1-2S3                 | 3S1-3S2         | 3S1-3S3               | 4S1-4S2                     | 4S1-4S3   | 5S1-5S2 (SHORT 3S2-A) | 5S1-5S3 (SHORT 3S3-A) |
| VA  | 20        | 20            | --                  | --                      | --              | --                    | --                          | --        | 20                    | 20                    |
| CLASS   | 5P        | 5P            | PX                  | PX                      | PX              | PX                    | PX                          | PX        | 0.2 S                 | 0.2 S                 |
| ALF/ISF   | 20        | 20            | --                  | --                      | --              | --                    | --                          | --        | ≤5                    | ≤5                    |
| Vk (V) min.   | --        | --            | 300                 | 40(Rct+10)              | 350             | 80(Rct+5)             | 350                         | 80(Rct+5) | --                    | --                    |
| max Iexc at Vk (mA)                                       | --        | --            | 50                  | 30                      | 50              | 30                    | 50                          | 30        | --                    | --                    |
| Rct (Ω)   | --        | --            | ≤3                  | ≤5                      | ≤3              | ≤5                    | ≤3                          | ≤5        | --                    | --                    |
| Total weight  |           | 720 ±10% kg   |                     | Oil weight              |                 | 180 ±10% kg           |                             |           |                       |                       |

234±0.5

240

R2

94±0.5

100

Ø1.7 (04 Nos.)

Variation of Tan Delta Value from 10KV um/sqrt 3 shall be not exceed 15%.



**PFIFFNER** Instrument Transformers Pvt.Ltd.  
NASHIK, INDIA

**CURRENT TRANSFORMER**

SERIAL NO. -----

YEAR -----

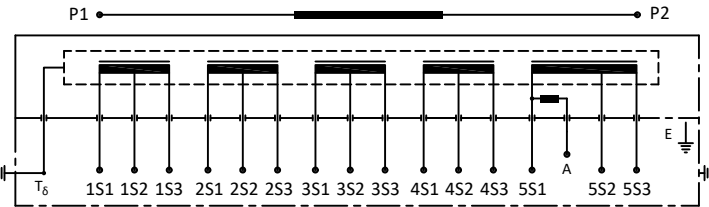

140±0.2

148

98±0.2

105



Ø1.7 (04 Nos.)

**CAUTION :** - Short all sec. terminals when not in use or before disconnecting burdens. Also check bellows position.  
- Capacitance & tan delta terminal 'T<sub>0</sub>' shall always be connected to earth & disconnect only for measurement.

Drawing approval subject to valid vendor registration

CHIEF ENGINEER/PROJECTS  
APTRANSCO/Vs/Vijayawada

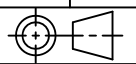
Customer : TRANSMISSION CORPORATION OF ANDRA PRADESH LTD.

|   |                           |                                 |            |   |   |
|---|---------------------------|---------------------------------|------------|---|---|
| 01  | AS PER CUSTOMER COMMENTS. |                                 |            | CHM   | 17.04.2023  |
| REV.NO.   | DESCRIPTION               |                                 |            | APPV'D  | REV. DATE   |
| GEN. TOL. : NA  |                           | MATERIAL :                      |            |  |   |
| WEIGHT : NA   |                           | 1mm thick Aluminium metal photo |            |   |   |
|   | NAME                      | SIGN                            | DATE       | SPEC : NA   | ALL DIMENSION ARE IN MM. UNLESS OTHRWISE SPECIFIED. |
| DRAWN   | M.D.                      |                                 | 06.03.2023 |   | SCALE : N.T.S.                                      |
| CHK'D   | M.C.                      |                                 | 06.03.2023 | FINISH : NA   | SHEET SIZE : A3                                     |
| APPV'D  | R.P.                      |                                 | 06.03.2023 |   | DWG NO.   |
|  <p><b>PFIFFNER</b><br/>Instrument Transformers Pvt.Ltd.<br/>NASHIK, INDIA</p> |                           |                                 |            | TITLE : RATING PLATE<br>245 kv CT   |   |
|   |                           |                                 |            | SHEET 1 OF 1  | REV. NO. : 01                                       |

This document must not be copied without our written permission and the content and nor be used for any unauthorised purpose. Contravention will be prosecuted. PFIFFNER

to be checked during acceptance tests.

2. For EPC contractors only.

IF IN DOUBT ASK

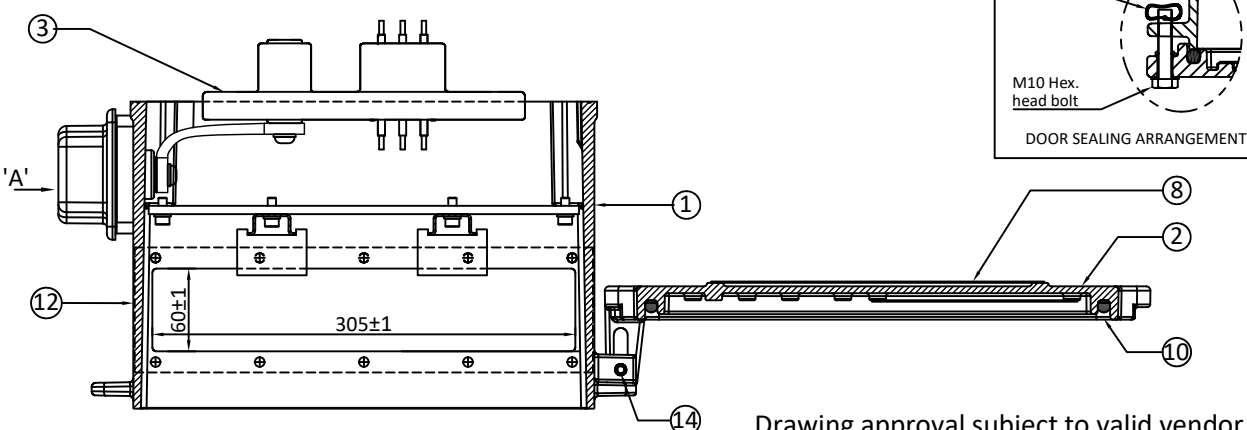

| SR.NO. | DESCRIPTION                                      | QTY.       | MATERIAL                   |
|--------|--|------------|----------------------------|
| 1      | TERMINAL BOX                                     | 1          | ALUMINIUM                  |
| 2      | TERMINAL BOX DOOR                                | 1          | ALUMINIUM                  |
| 3      | SECONDARY LEAD OUT                               | 1          | EPOXY                      |
| 4      | STUD TYPE TERMINAL BLOCK (KBT M4 )               | 16+2 SPARE | MAKE - ELMEX               |
| 5      | TERMINAL CARRIER RAIL                            | 2          | STEEL                      |
| 6      | GLAND PLATE                                      | 1          | ALUMINIUM                  |
| 7      | GLAND PLATE GASKET                               | 1          | NEOPRENE RUBBER            |
| 8      | RATING PLATE                                     | 1          | ALUMINIUM                  |
| 9      | SCHEMATIC DIAGRAM PLATE                          | 1          | ALUMINIUM                  |
| 10     | DOOR GASKET                                      | 1          | EPDM RUBBER                |
| 11     | DOOR EARTHING CABLE                              | 1          | PVC INSULATED COPPER CABLE |
| 12     | WARNING STICKER                                  | 1          | ALUMINIUM                  |
| 13     | TAN DELTA (T <sub>δ</sub> ) MEASUREMENT TERMINAL | 1          | BRASS                      |
| 14     | HINGES   | 2          | S.S. TENSION PIN           |
| 15     | TAN DELTA EARTH LINK                             | 1          | COPPER (NICKEL PLATED)     |

Drawing approval subject to valid vendor registration

Variation of Tan Delta Value from 10KV um/sqrt 3 shall be not exceed 15%.

DEGREE OF PROTECTION : IP 55

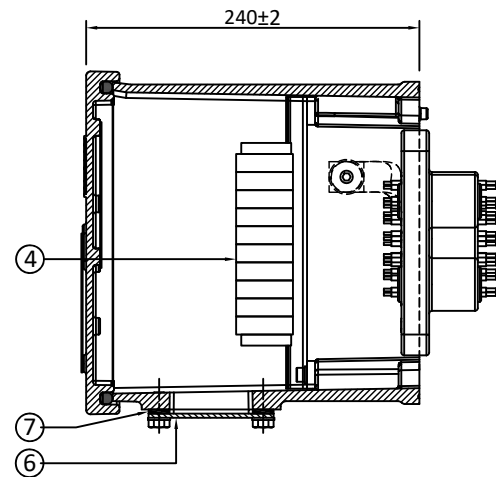
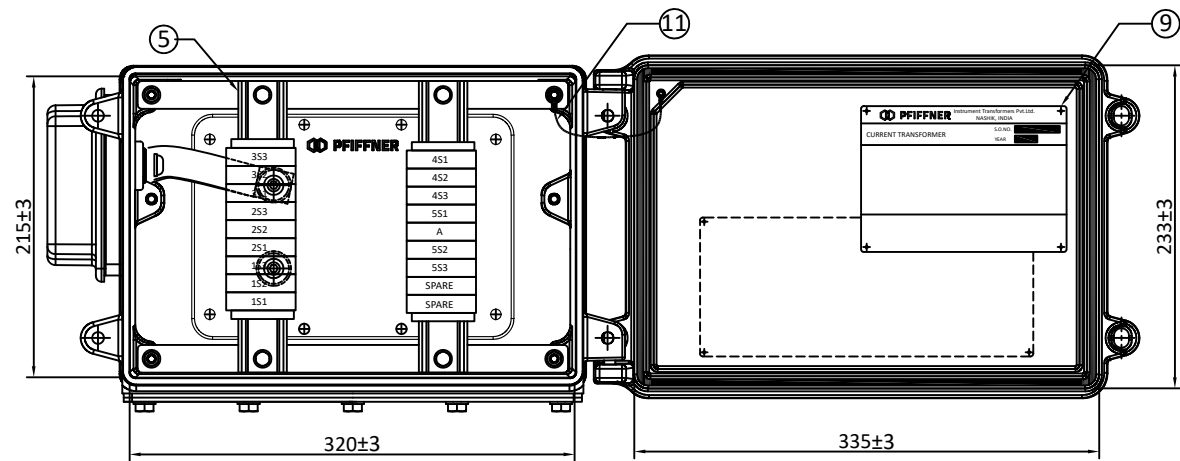

Customer : TRANSMISSION CORPORATION OF ANDRA PRADESH LTD.

This document must not be copied without our written permission and the content and nor be used for any unauthorised purpose. Contravention will be prosecuted. PFIFFNER

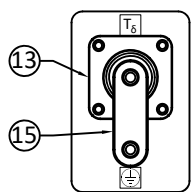

Detail 'A'

**WARNING**  
"T<sub>δ</sub>" TERMINAL - DO NOT OPEN WHEN IN SERVICE

Item : 12

CHIEF ENGINEER/PROJECTS  
APTRANSCO/VS/Vijayawada

|               |                           |                             |                  |
|---------------|---------------------------|-----------------------------|------------------|
| 01            | AS PER CUSTOMER COMMENTS. | CHM                         | 17.04.2023       |
| REV.NO.       | DESCRIPTION               | APPV'D                      | REV. DATE        |
| GEN. TOL : NA |                           | MATERIAL : NA               |                  |
| WEIGHT : NA   |                           |                             |                  |
| NAME          | SIGN                      | DATE                        | SPEC : NA        |
| DRAWN         | M.D.                      | 06.03.2023                  | FINISH : NA      |
| CHK'D         | M.C.                      | 06.03.2023                  | SCALE : N.T.S.   |
| APPV'D        | R.P.                      | 06.03.2023                  | SHEET SIZE : A3  |
|               |                           | TITLE :                     | DWG NO.          |
|               |                           | TERMINAL BOX GA<br>245KV CT | APTR-03.31.245J3 |
|               |                           | SHEET 1 OF 1                | REV. NO. : 01    |

NOTE:-1. Drawings approval subject to valid type test reports, to be checked during acceptance tests.  
2. For EPC contractors only.

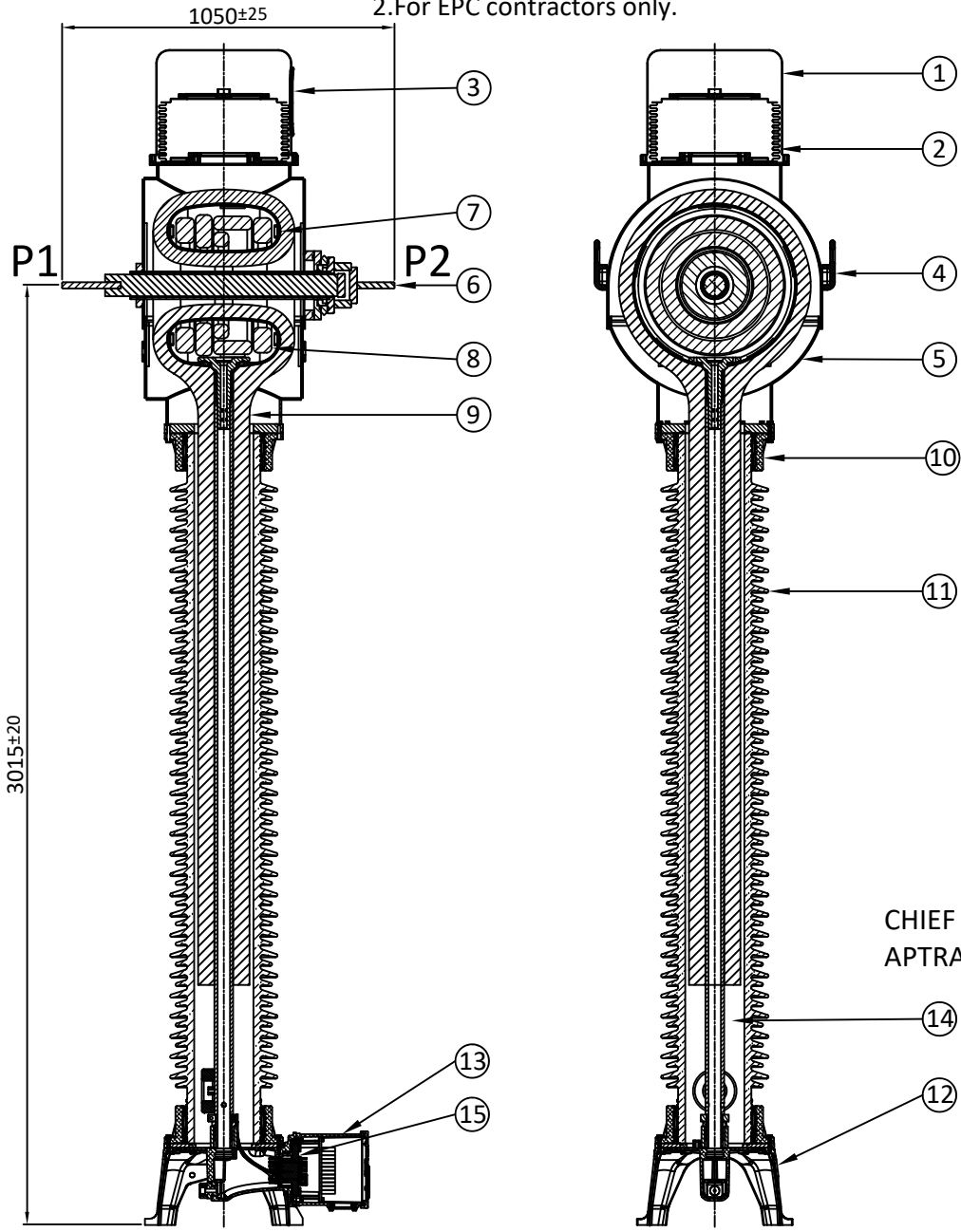

| NO. | QTY. | DESCRIPTION            | MATERIAL                |
|-----|------|------------------------|-------------------------|
| 01  | 01   | BELLOWS COVER          | ALUMINIUM               |
| 02  | 01   | BELLOWS                | STAINLESS STEEL         |
| 03  | 01   | BELLOW LEVEL INDICATOR | POLYCARBONATE           |
| 04  | 02   | LIFTING LUG            | ALUMINIUM               |
| 05  | 01   | HOUSING                | ALUMINIUM               |
| 06  | 02   | PRIMARY TERMINAL       | ALUMINIUM               |
| 07  | 01   | CORE BOX               | ALUMINIUM               |
| 08  | 01   | SECONDARY CORES        | CRGO & NANO             |
| 09  | 01   | ACTIVE PART            | OIL IMPREGNATED PAPER   |
| 10  | 02   | INSULATOR FLANGE       | ALUMINIUM               |
| 11  | 01   | INSULATOR              | PORCELAIN               |
| 12  | 01   | BASE                   | ALUMINIUM               |
| 13  | 01   | TERMINAL BOX           | ALUMINIUM               |
| 14  | --   | INSULATING OIL         | EHV Grade - MINERAL OIL |
| 15  | 01   | SECONDARY LEADOUT      | EPOXY                   |

Notes:

- Insulating oil shall be EHV Grade as per IS 335, IEC 296
- Core : CRGO Si-Fe/ Equivalent high permeability material, MU- Metal, NANO - crystalline
- Secondary winding - Enamelled copper

Drawing approval subject to valid vendor registration

CHIEF ENGINEER/PROJECTS  
APTRANSCO/VIS/Vijayawada

Variation of Tan Delta Value from 10KV um/sqrt 3 shall be not exceed 15%.

This document must not be copied without our written permission and the content and nor be used for any unauthorised purpose. Contravention will be prosecuted. © PFIFFNER

IF IN DOUBT ASK

|  |               |      |            |                                       |   |
|--|---------------|------|------------|---------------------------------------|---|
| REV.NO.  | DESCRIPTION   |      |            | APPV'D                                | REV. DATE   |
| GEN. TOL. : NA   | MATERIAL : NA |      |            |                                       |   |
| WEIGHT : NA  |               |      |            |                                       |   |
|  | NAME          | SIGN | DATE       | SPEC : NA                             | ALL DIMENSION ARE IN MM. UNLESS OTHRWISE SPECIFIED.     |
| DRAWN  | M.D.          |      | 07.03.2023 | FINISH : NA                           | SCALE : N.T.S.  |
| CHK'D  | M.C.          |      | 07.03.2023 |                                       | SHEET SIZE : A3   |
| APPV'D   | R.P.          |      | 07.03.2023 |                                       | DRG NO.   |
| <b>PFIFFNER</b><br>Instrument Transformers Pvt.Ltd.<br>NASHIK, INDIA |               |      |            | TITLE :<br>SECTIONAL VIEW<br>245KV CT | <b>APTR-03.31.245J4</b><br>SHEET 1 OF 1   REV. NO. : 00 |

**Annexure-A**  
**GUARANTEED TECHNICAL PARTICULARS FOR CURRENT TRANSFORMERS**

JOF 245 W OUTDOOR CURRENT TRANSFORMERS  
 (245kV 500A CT, 5 Core 31mm Creepage)

| Sl.No | Particulars  | Description  |
|-------|--|--|
| 1     | Type of tank/Installation<br>Dead/Live<br>Tank Type              | Live Tank, Single Phase, Oil Filled,<br>Outdoor Type   |
| 2     | Type of mounting   | Pedestal Mounting  |
| 3     | Manufacturer's Name and<br>address and<br>Country of Manufacture | PFIFNER Instrument Transformers Pvt Limited, Gat No.<br>176, 178/2, Sarul, Nashik 422010, Maharashtra, INDIA           |
| 4     | Whether Conforming to IEC<br>61869 Standard                      | Yes, IEC 61869-1&2   |
| 5 a)  | Primary and Secondary winding<br>made out of                     | Primary - Aluminium alloy of C/S area 1250mm <sup>2</sup><br>Secondary - Copper alloy of C/S area 1.168mm <sup>2</sup> |
| b)    | Material used for providing<br>Primary Terminals                 | Aluminium  |
| c)    | Material used for providing<br>secondary Terminals               | Copper Alloy   |
| d)    | Whether Primary is Rigid Bar<br>type in case of live tank        | Yes, Rigid Bar type  |
| 6     | Rated primary voltage (kV rms)                                   | 220 kV   |
| 7     | Rated highest voltage (kV rms)                                   | 245 kV   |
| 8     | Rated frequency (Hz)   | 50 Hz  |
| 9     | Rated primary current (A)  | 500A   |
| 10    | Rated secondary current (A)                                      | 1A   |
| 11    | Ratio taps (on secondary side<br>only)                           | On Secondary Only  |
| 12    | Type of insulation   | Class A  |
| 13    | Seismic acceleration (g)   | 0.3g   |
| 14    | RIV at 1.1 x Rated voltage (mv)                                  | < 500 Micro Volts  |
| 15    | Tank material and Tank coating                                   | Aluminium Tank with Natural Finish   |
| 16    | Hardware exposed to<br>atmosphere                                | Stainless Steel  |
| 17    | Bolts, Nuts and Washers  | Stainless Steel  |
| 18    | Porcelain housing and it make<br>(Single<br>piece only)          | IEC/Modern/Ravikiran   |
| 19    | Sealing (Nitrogen gas<br>cushion/Metal<br>Bellow)                | Stainless Steel Bellows  |
| 20    | Instrument security factor                                       | ≤ 5 (For Metering core )   |
| 21    | Whether Tan Delta test tap<br>provided                           | Yes  |
| 22    | Whether secondary terminal<br>plate is of moulded epoxy resin    | Yes (Epoxy Monoblock)  |

Variation of Tan Delta Value from 10KV um/sqrt 3 shall be not exceed 15%.

Variation of Tan Delta Value from 10KV  $\mu\text{m}/\sqrt{3}$  shall be not exceed 15%.

| Sl.No | Particulars   | Description  |
|-------|---|--|
|       | type  |  |
| 23    | Whether primary terminal bushings are of molded Epoxy cast resin/Glass fiber reinforced Polymer | Not Applicable   |
| 24    | Whether all seals are of "O" ring type  | Yes, "O" Rings   |
| 25    | Whether all "O" Rings are fixed in machined grooves with adequate space for compression'        | Yes<br><br>CHIEF ENGINEER/PROJECTS<br>APTRANSCO/VS/Vijayawada                                  |
| 26    | Whether the main hollow insulator has the flanges cemented at both ends                         | Yes  |
| 27    | Whether "O" Rings are of Nitrile butyl rubber or Viton  | Yes (Viton)  |
| 28    | Whether the Short circuit Ampere turns of the CT being supplied is same as type tested CTs      | Yes  |
| 29    | Tan Delta   | < 0.5%   |
| 30    | Whether ratio selection is achieved only in secondary   | Yes  |
| 31    | Whether ratio selection is achieved only in secondary   | Yes  |
| 32    | Whether Non return drain valve for oil sampling is arranged for 132kV and above CT/IVT          | Yes  |
| 33    | Acceptable limit of temperature   | As per IS/IEC  |
| 34    | Partial Discharge Level   | < 5pC at $1.2 \times U_m / \sqrt{3}$ , < 10pC at $U_m$ (where $U_m$ is highest system voltage) |
| 35    | Rated short time withstand current for 1 sec. duration (kA rms)                                 | 40 kA  |
| 36    | Rated dynamic withstand current (kAp)   | 100  |
| 37    | Rated continuous thermal current (pu) where pu = rated current                                  | Rated Extended Primary Current<br>120%   |
| 38    | 1.2/50 micro second impulse withstand voltage (kVp)   | 1050 kVp   |

Drawing approval subject to valid vendor registration

| Sl.No | Particulars  | Description  |                |               |               |        |
|-------|--|--|----------------|---------------|---------------|--------|
| 39    | One minute power frequency withstand voltage (kV rms) of primary winding (Dry) | 460 kV rms   |                |               |               |        |
| 40    | One minute power frequency withstand voltage of secondary winding (kV rms)     | 3 kV   |                |               |               |        |
| 41 a) | Minimum total Creepage distance of insulator bushing (mm)                      | 31mm/kV Porcelain Insulator / 7595 mm  |                |               |               |        |
| b)    | Protected Creepage of distance of bushing (mm)                                 | Not Applicable   |                |               |               |        |
| 42    | Details of Cores   | Core   | Core 2         | Core 3        | Core4         | Core 5 |
| i)    | Current Ratios A/A   | 500-300/1-1-1-1-1A   |                |               |               |        |
| ii)   | Output burden (VA)   | 20   | NA             | NA            | NA            | 20     |
| iii)  | Class of accuracy  | 5P20   | PX             | PX            | PX            | 0.2S   |
| iv)   | ISF  | NA   | NA             | NA            | NA            | 5      |
| v)    | Min. knee point voltage (kpV) in volts   | NA   | 40(Rct+10)-300 | 80(Rct+5)-350 | 80(Rct+5)-350 | NA     |
| vi)   | Secondary resistance corrected to 75 deg.C in ohms                             | NA   | 5-3            | 5-3           | 5-3           | NA     |
| vii)  | Max. Exciting current (mA) at Vk- 100% of knee point voltage                   | NA   | 30-50          | 30-50         | 30-50         | NA     |
| 43    | Weight of oil (Kg.)  | 180kg ± 10% (approx.)  |                |               |               |        |
| 44    | Approximate weight of copper used (Kg)   | 25kg   |                |               |               |        |
| 45    | Approximate weight of Steel used (Kg)  | 100kg  |                |               |               |        |
| 46    | Total Weight (Kg.)   | 720 ± 10% (approx.)  |                |               |               |        |
| 47    | Mounting details   | 450mm x 450mm (Refer GA Drawing)   |                |               |               |        |
| 48    | Overall dimensions   | Please Refer Attached GA Drawing   |                |               |               |        |
| 49    | Characteristics (whether graphs enclosed):                                     | No   |                |               |               |        |
| a)    | Ratio and phase angle curves   | No   |                |               |               |        |
| b)    | Magnetization curves   | No   |                |               |               |        |
| c)    | Ratio correction factor curves   | No   |                |               |               |        |
| 50    | Core   |  |                |               |               |        |
| a)    | Area of cross section (sq.cm.)   | As per Standard Design Practice  |                |               |               |        |
| b)    | Flux density at rated primary current and rated burden                         | As Per Standard Design Practice  |                |               |               |        |
| c)    | Grade  | Nano-crystalline core for Metering<br>CRGO steel or other equivalent alloys for Protection Cores |                |               |               |        |
| 51    | Cantilever strength (kG)   | 400 KG   |                |               |               |        |

1. Minimum 300mm plinth shall be maintained for CT/PT/CVT/ Isolators/IVT in the substation during foundation works to ensure safe live to ground clearance as per IE rules.
2. Since the supply of terminal connectors is not in the scope of manufacturers as mentioned in the drawings. The EPC contractors shall be instructed to supply the same in line with CT/PT/CVT/Isolator /IVTs requirement and capability.