

725 ±50

BELLOW INDICATOR

1. ALL FERROUS PARTS EXPOSED TO THE ATMOSPHERE SHALL BE PAINTED WITH P.U PAINT SHADE 631 OF IS: 5.
2. MAKE OF BUSHING: IEC/MODERN/BHEL/ABL/CJJI
3. TOTAL CREEPAGE DISTANCE :- 6125 mm (MIN)
4. QUANTITY OF OIL :-175 LITRES APPROX.
5. TOTAL WEIGHT OF CT : 600 KGS APPROX.
6. PRIMARY WINDING SHALL BE BAR TYPE.
7. ALL GASKETS SHALL BE FIXED IN PROPERLY MACHINED GROOVES.
8. ALL HARDWARE SHALL BE HOT DIP GALVANIZED.
9. TRANSFORMER OIL AS PER IEC : 60296.
10. ALL GASKETS SHALL BE MADE OF NITRILE BUTYL RUBBER.

FOR EPC CONTRACTS ONLY

S.No.	DESCRIPTION	QTY	MATL
1	OIL FILLING PORT	1	MS
2	BELLOW	1	S.S
3	BELLOW DOME 1.5mm THICK	1	M.S/ALUMIUM
4	OIL LEVEL INDICATOR	1	AL/BRASS
5	PRIMARY TERMINAL Ø40x80mm	1	ALUMINIUM
6	OIL TANK WITH COVER	1	MS
7	BUSHING	1	PORCELAIN
8	BUSHING FLANGE (CEMENTED)	2	GI/CI
9	BASE	1	MS
10	SECONDARY TERMINAL BOX	1	MS
11	LIFTING HOOK	4	MS
12	EARTHING FLAT 80X50X8THICK	2	MS
13	NAME AND RATING PLATE	1	AL. ANODIZED
14	OIL DRAIN PLUG	1	MS
15	MOUNTING HOLES Ø20	4	MS
16	BUSHING GASKET	2	N.BR

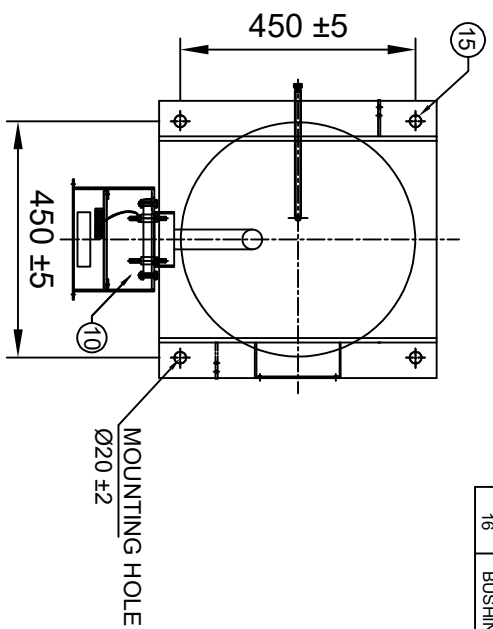
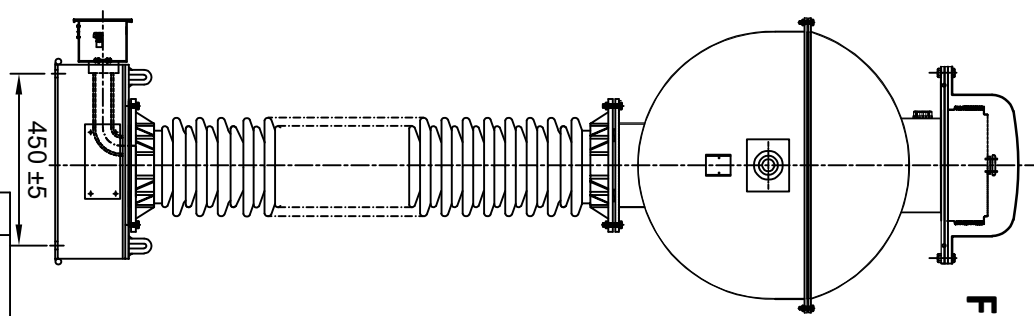
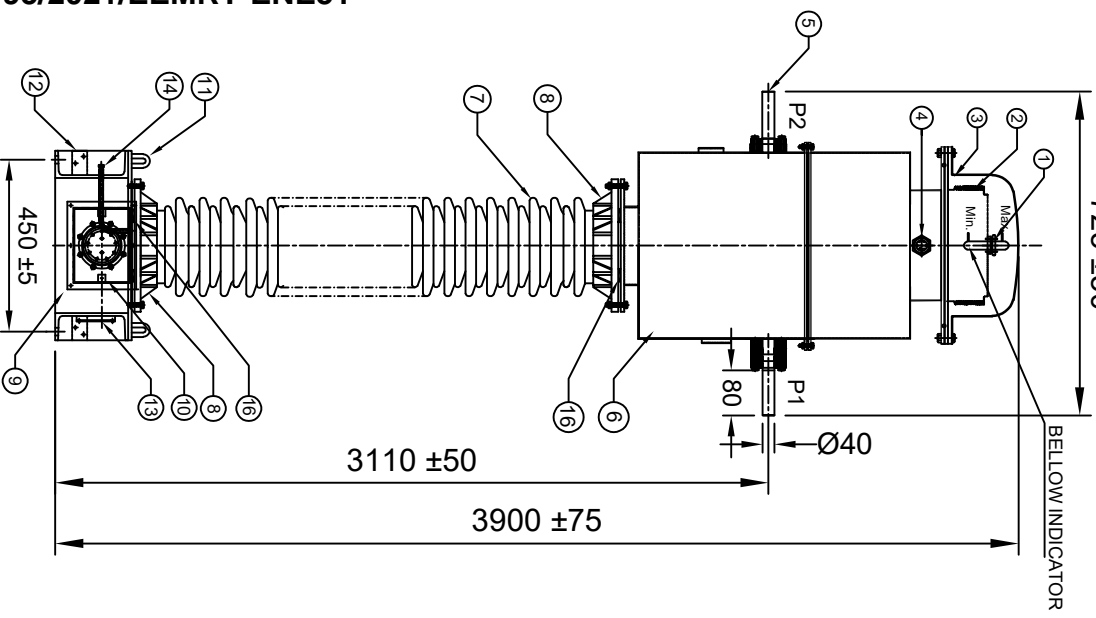

MOUNTING DETAILS

Chief Engineer
Power Systems, Planning & Design
APTtransco

CLIENT : TRANSMISSION CORPORATION OF ANDHRA PRADESH LIMITED
PROJECT NAME : AS APPLICABLE
UNLESS OTHERWISE SPECIFIED

1. ALL DIMENSIONS ARE IN mm.
2. TOLERANCE WHEREVER NOT INDICATED ±5%

DGN.	DATE	NAME	MATERIAL
SPS	03.04.2021		
DRN.	03.04.2021	TUSHAR	
CHD.	03.04.2021	B.S	

SEE TABLE

MEHRU
MEHRU ELECTRICAL & MECHANICAL ENGINEERS (P) LTD.

Drawing approval subject to valid vendor registration

REV.	REVISION DESCRIPTION	DATED INITIALS
R0	FOR APPROVAL	03.04.2021

SHEET No.	1 OF 7
-----------	--------

TITLE :
GENERAL ARRANGEMENT DRAWING
FOR 220KV CURRENT TRANSFORMER
BAR TYPE CT

DRG.NO	ME-220CT-GA-03
--------	----------------

NOTE : DRAWING APPROVAL SUBJECT TO VALID TYPE TEST REPORTS, TO BE

CHECKED DURING ACCEPTANCE TESTS.

MEHRU

LIVE TANK CURRENT TRANSFORMER

MADE TO IS : 16227

HIGHEST SYSTEM VOLTAGE	245 KV	INSULATION LEVEL	460/1050 KV
RATED S.T.C	40 kA for 1 Sec	RATED FREQUENCY	50 HZ
NOMINAL SYSTEM VOLTAGE	220 KV	CORE 1	
RATIO	PRIMARY(Amp) SECONDARY (Amp)	600 1	
SECONDARY TERMINALS		1S1-1S2	
RATED BURDEN		5 VA	
ACCURACY CLASS		0.2S	
ALF / ISF		<5	
YEAR OF MANUFACTURE	2021	SERIAL NO.	

* RATED CONT. THERMAL CURRENT = 120% OF THE RATED PRIMARY CURRENT

* TOTAL WEIGHT OF CT :- 600 KG. APPROX.

* TOTAL CREEPAGE DISTANCE :- 6125 mm. (MIN.) , * QUANTITY OF OIL :- 175 LITERS APPROX.

MADE IN INDIA BY

MEHRU ELECTRICAL AND MECHANICAL ENGINEERS (P) LTD.

SP2/180, RICO INDUSTRIAL AREA, KEHRANI, BHIVADI - RAJASTHAN - 301019

SUITABLE FOR HOT LINE WASHING

CONNECTION DIAGRAM

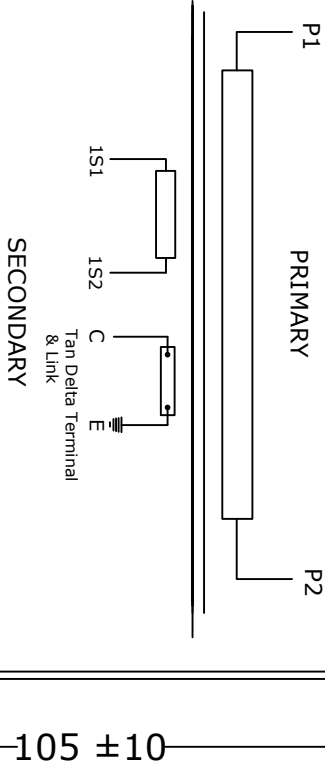

SECONDARY

CAUTION

- 1) SHORT CIRCUIT AND EARTH ALL SECONDARIES TERMINALS ARE NOT IN USE.
- 2) ALWAYS KEEP TAN DELTA TESTING TERMINAL 'C' SHORTED TO EARTH DURING OPERATION.
- 3) DO NOT REMOVE EARTH LINK WHEN IN OPERATION.

225 ± 15

105 ± 10

NOTES:-

1. MATERIAL OF NAME PLATE :- ALUMINIUM ANODIZED.
2. THICKNESS OF NAME PLATE :- 1.2 mm.
3. SERIAL NO. SHALL BE ENGRAVE BEFORE DISPATCH.

* PRIMARY WINDING AREA : 1257 sq.mm

* CURRENT DENSITY : 0.57 A/sq.mm

Drawing approval subject to valid vendor registration

REV.	REVISION DESCRIPTION	DATED INITIALS
R0	FOR APPROVAL	03.04.2021

CLIENT : TRANSMISSION CORPORATION OF ANDHRA PRADESH LIMITED		PROJECT NAME : AS APPLICABLE	
UNLESS OTHERWISE SPECIFIED		1. ALL DIMENSIONS ARE IN mm.	
2. TOLERANCE WHEREVER NOT INDICATED ± 5%		3. SERIAL NO. SHALL BE ENGRAVED BEFORE DISPATCH.	
DGN.	DATE	NAME	MATERIAL
DRN.	03.04.2021	SFS	AL. ANODIZED
CHD.	03.04.2021	TUSHAR	
SCALE:	N.T.S	B.S	
TITLE :		NAME PLATE DRAWING FOR	
SHEET No.		220KV CURRENT TRANSFORMER	
3 OF 7		RATIO : 600/1A	
		BAR TYPE CT	
DRG.NO	MEHRU ELECTRICAL & MECHANICAL ENGINEERS (P) LTD.		MEHRU
ME-220CT-NP-03			

Chief Engineer
Power Systems, Planning & Design
APTransco

4609495/2021/FEMRT-FNE51

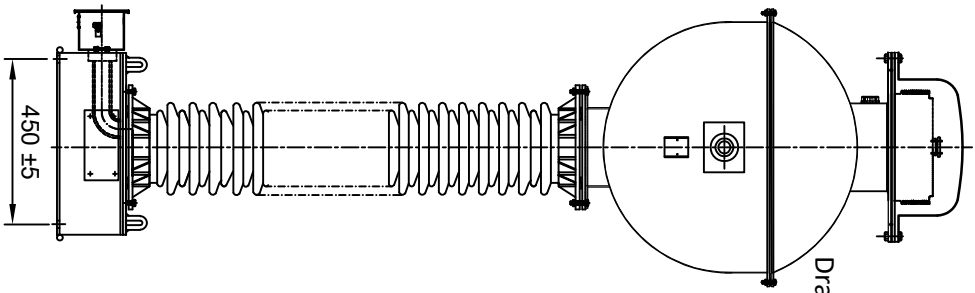
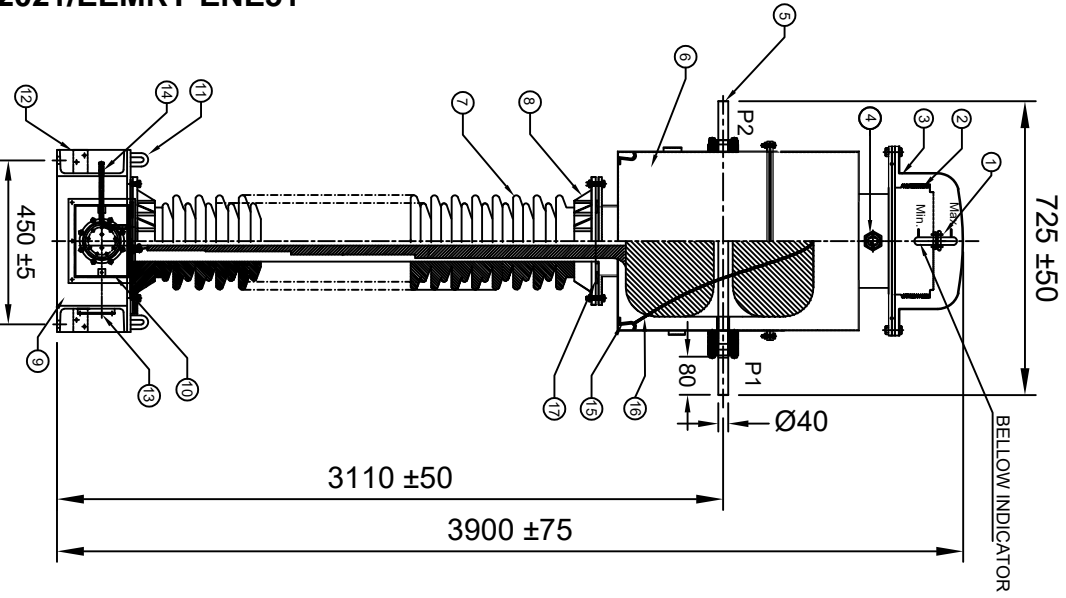
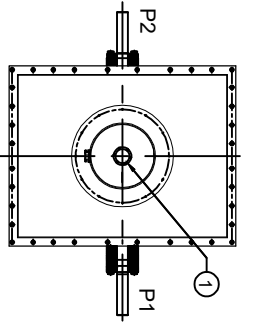

- NOTES :**
1. ALL FERROUS PARTS EXPOSED TO THE ATMOSPHERE SHALL BE PAINTED WITH P.U PAINT SHADE 631 OF IS: 5.
 2. MAKE OF BUSHING: IEC/MODERN/BHEL/ABIL/CIJ
 3. TOTAL CREEPAGE DISTANCE :- 6125 mm (MIN)
 4. QUANTITY OF OIL :-175 LITRES APPROX.
 5. TOTAL WEIGHT OF CT : 600 KGS APPROX.
 6. PRIMARY WINDING SHALL BE BAR TYPE.
 7. ALL GASKETS SHALL BE FIXED IN PROPERLY MACHINED GROOVES.
 8. ALL HARDWARE SHALL BE HOT DIP GALVANIZED.
 9. TRANSFORMER OIL AS PER IEC : 60296.
 10. ALL GASKETS SHALL BE MADE OF NITRILE BUTYL RUBBER.
 11. CORE/SECONDARY WINDINGS SHALL BE ENCASED IN ALUMINUM SHELL.

Drawing approval subject to valid vendor registration

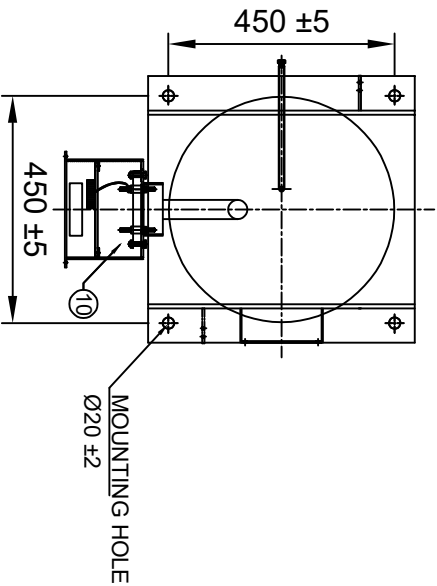

MOUNTING DETAILS

Chief Engineer
Power Systems, Planning & Design
APTranSCO

S.No.	DESCRIPTION	QTY	MATL
1	OIL FILLING PORT	1	M.S
2	BELLOW	1	S.S
3	BELLOW DOME	1	M.S/ALUMINIUM
4	OIL LEVEL INDICATOR	1	AL./BRASS
5	PRIMARY TERMINAL Ø40xØ80mm	1	ALUMINIUM
6	OIL TANK WITH COVER	1	M.S
7	BUSHING	1	PORCELAIN
8	BUSHING FLANGE (CEMENTED)	2	GICI
9	BASE	1	M.S
10	SECONDARY TERMINAL BOX	1	M.S
11	LIFTING HOOK	4	M.S
12	EARTHING FLAT (80x50x8 Thick)	2	M.S
13	NAME AND RATING PLATE	1	ALUMINIUM ANODIZED
14	OIL DRAIN PLUG	1	M.S
15	HOOK FOR COIL TIGHTENING	4	M.S
16	COL TIEING STRING	--	NYLON
17	BUSHING GASKET	2	N.B.R

CLIENT : TRANSMISSION CORPORATION OF ANDHRA PRADESH LIMITED
PROJECT NAME : AS APPLICABLE
UNLESS OTHERWISE SPECIFIED
1. ALL DIMENSIONS ARE IN mm.
2. TOLERANCE WHEREVER NOT INDICATED ±5%

DGN.	DATE	NAME	MATERIAL
03.04.2021		SPS	SEE TABLE
DRN.	03.04.2021	TUSHAR	
CHD.	03.04.2021	BLS	

MEHRU ELECTRICAL & MECHANICAL ENGINEERS (P) LTD.

REV.	REVISION DESCRIPTION	DATED INITIALS
R0	FOR APPROVAL	03.04.2021

SHEET No. 2 OF 7

TITLE :
SECTIONAL ARRANGEMENT DRAWING FOR 220KV CURRENT TRANSFORMER RATIO : 600/1A BAR TYPE CT

DRG.NO ME-220CT-SE-03

Drawing approval subject to valid vendor registration

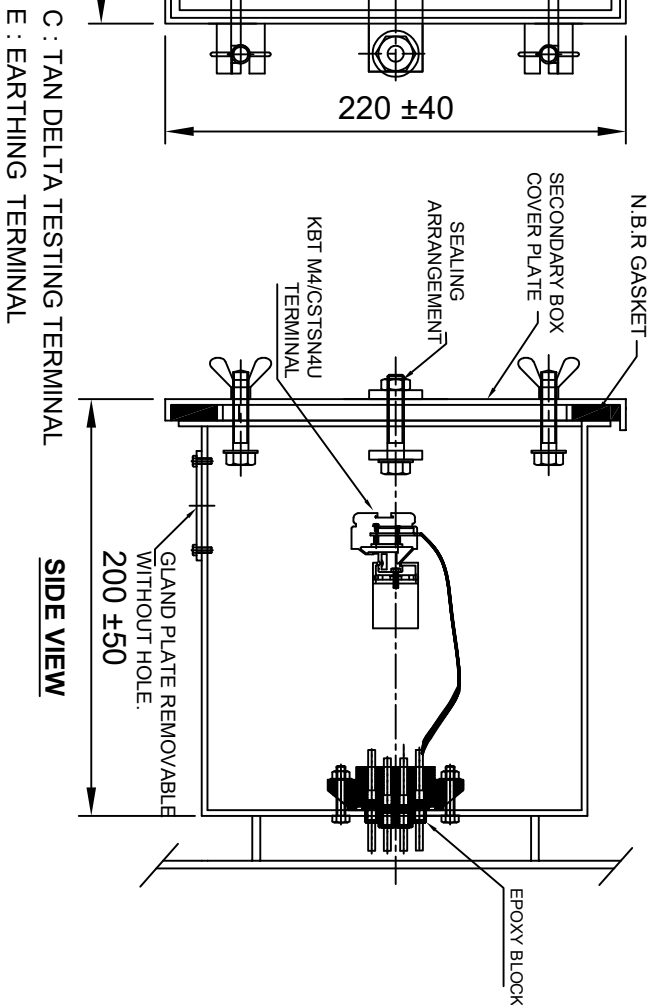
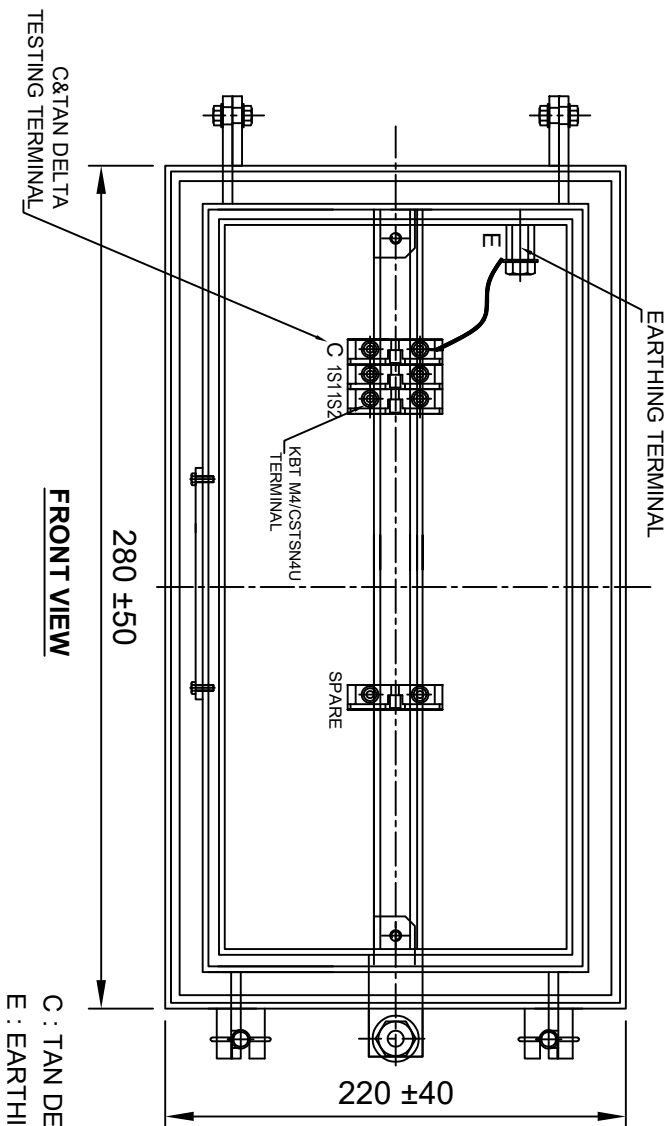

TERMINAL (DETAIL)

FRONT SIDE

MATERIAL: POLYAMIDE

MAKE: ELMEX/CONNECTWELL

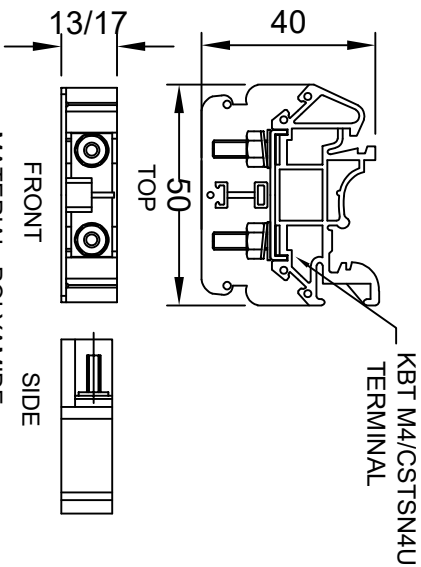

NOTES:-

1. SECONDARY TERMINAL BOX SHALL BE PROVIDE GLAND PLATE REMOVABLE WITHOUT HOLE.
2. SECONDARY TERMINAL BOX SHALL BE PROVIDED WITH COVER.
3. M.S SHEET THICKNESS FOR TERMINAL BOX 3.0mm & FOR COVER 2.0mm.
4. MATERIAL OF GASKET : NITRILE BUTYL RUBBER GASKET.
5. DEGREE OF PROTECTION : IP 55.
6. 20% SPARE TERMINAL SHALL BE PROVIDED.

Chief Engineer
 Power Systems, Planning & Design
 APTransco

REV.	REVISION DESCRIPTION	DATED INITIALS
RO	FOR APPROVAL	03.04.2021

CLIENT : TRANSMISSION CORPORATION OF ANDHRA PRADESH LIMITED		PROJECT NAME : AS APPLICABLE	
UNLESS OTHERWISE SPECIFIED			
1. ALL DIMENSIONS ARE IN mm.			
2. TOLERANCE WHEREVER NOT INDICATED ±9%			
DGN	DATE	NAME	MATERIAL
DEN	03.04.2021	SPS	M.S
CHD	03.04.2021	TUSHAR	
SCALE	N.T.S		
TITLE :			
SECONDARY TERMINAL BOX DRAWING FOR 220KV CURRENT TRANSFORMER RATIO : 600/1A BAR TYPE CT			
DRG NO	MEHRU ELECTRICAL & MECHANICAL ENGINEERS (P) LTD.		
ME-220CT-STB-03			

Drawing approval subject to valid vendor registration

Chief Engineer
Power Systems, Planning & Design
APTransco

4609495/2021/EEMRT-ENF51 - Specified Technical Particulars for 220kV Current Transformer

Sl. No.	Item Description	Unit	GTP as per Bid
E	CURRENT TRANSFORMER		
1	Make		Mehru Electrical & Mechanical Engineers (P) Ltd, Bhiwadi, (Raj), Inida
2	Type and Designation		Outdoor, Oil Cooled Live Tank Type, Current Transformer
3	Applicable standards		IS 16227
4	Class		A
5	Rated Voltage	220 kV	220 kV
6	Rated Primary current	Amps	600A
7	Rated Secondary current	Amps	1
8	Rated output (Burden)	VA	Core:1 :- 5VA
9	Class of accuracy		Core:-1:0.2S
10	Accuracy limit factor		N/A
11	Knee point voltage	Volts	N/A
12	CT Resistance of secondary winding corrected to 75 deg.C	Ohms	N/A
13	Magnetising current at knee-voltage point @highest tap		N/A
14	secondary limiting voltage	kV	As per IS 16227
15	Instrument security factor for winding meant for metering		<5
16	One minute Power Frequency withstand test voltage of		
a)	Primary winding	kV (rms)	460
b)	Secondary winding	kV (rms)	3
17	Impulse withstand voltage of primary winding	kV (peak)	1050
18	One minute dry P.F. withstand voltage of primary winding	kV (rms)	460
19	Creepage distance	mm	25mm/kV i.e. 6125mm (Min.)
20	Rated continuous thermal current	Amps	120% of rated primary current
21	Ratios available at highest taps		Yes
22	Rated short time thermal current	kA (rms)	40 kA
23	Rated time for above	Sec.	1
24	Rated dynamic current for primary	kA (Peak)	100
25	Class of insulation		A
26	Max. Temperature rise over ambient of 50 deg.C at any part of oil	deg.C	50c max

4609495/2021/EEMRT-ENE51

27			
a)	Radio interference voltage		As per IS 16227 Clause 6.11.2 <2500uV
b)	Partial discharge level		<10 pC at Um & <5 pc at 1.2Um/ $\sqrt{3}$
28	Temp. rise after passing short time thermal current for one second	deg.C	50c max
29	Current density in primary winding at		
a)	Normal rating		0.57 Amp/sqmm
b)	Short time rating of 1 Sec.		31.82 Amp/sqmm
c)	Dynamic rating		79.5 Amp/sqmm
30	Type of primary winding		Aluminum
31	No. of primary turns		1
32	No. of secondary turns		600
33	Flux density at knee point		N/A
34	Mounting details		450±5 x 450±5 mm
35	Source/grade of oil and standard with which it complies		EHV Grade Transformer Oil as per IS 335/IEC 60296 of any reputed make
36	Quantity of insulating oil	Litres	175 Ltr Approx
37	Weight of Oil	kg	140 Kgs Approx
38	Total Weight including Oil	kg	600kG Approx
39	Overall dimensions (mm)		3900±75 x 725±50 x 450±5 mm
40	Wheather sealed (if so, type of sealing)		Yes, By SS BELLOW
41	Tan delta		<0.005
42	a) Weight of Steel		150 kgs (Approx.)
	b) Wight of Aluminum		20 kgs (Approx.)
	c) Weight of copper		15 kgs (Approx.)

FOR EPC CONTRACTS ONLY

NOTE : DRAWING APPROVAL SUBJECT TO VALID TYPE TEST REPORTS, TO BE CHECKED DURING ACCEPTANCE TESTS.

Since the supply of terminal connectors is not in the scope of manufacturer as mentioned in the drawings, the EPC contractors shall be instructed to supply the same in line with CT/VT/CVT requirement and compatibility.

Chief Engineer
Power Systems, Planning & Design
APTransco