

- NOTES :**
1. ALL FERROUS PARTS EXPOSED TO THE ATMOSPHERE SHALL BE PAINTED WITH P. U PAINT SHADE 631 OF IS: 5.
  2. MAKE OF BUSHING: IEC/MODERN/BHEL/ABIL/CIJ
  3. TOTAL CREEPAGE DISTANCE :- 6125 mm (MIN)
  4. QUANTITY OF OIL :- 225 LITRES APPROX.
  5. TOTAL WEIGHT OF CT : 940 KGS APPROX.
  6. PRIMARY WINDING SHALL BE BAR TYPE.
  7. ALL GASKETS SHALL BE FIXED IN PROPERLY MACHINED GROOVES.
  8. ALL HARDWARE SHALL BE HOT DIP GALVANIZED.
  9. TRANSFORMER OIL AS PER IEC : 60296.
  10. ALL GASKETS SHALL BE MADE OF NITRILE BUTYL RUBBER.

S.No.	DESCRIPTION	QTY	MATL
1	OIL FILLING PORT	1	M.S
2	BELLOW	1	S.S
3	BELLOW DOME 1.5 mm THICK	1	M.S/ALUMIUM
4	OIL LEVEL INDICATOR	1	AL/BRASS
5	PRIMARY TERMINAL Ø50x100mm	1	ALUMINIUM
6	OIL TANK WITH COVER	1	M.S
7	BUSHING	1	PORCELAIN
8	BUSHING FLANGE (CEMENTED)	2	G/CI
9	BASE	1	M.S.
10	SECONDARY TERMINAL BOX	1	M.S
11	LIFTING HOOK	4	M.S
12	EARTHING FLAT 80X50X8THICK	2	M.S
13	NAME AND RATING PLATE	1	AL. ANODIZED
14	OIL DRAIN PLUG	1	M.S
15	MOUNTING HOLES Ø20	4	M.S
16	BUSHING GASKET	2	NBR

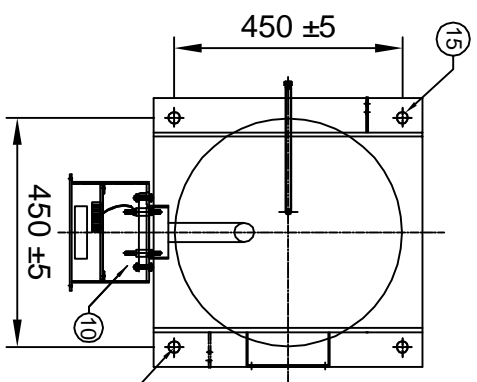

**MOUNTING DETAILS**

Chief Engineer  
Power Systems, Planning & Design  
APTransco  
MOUNTING HOLE  
Ø20 ±2

Drawing approval subject to valid vendor registration

CLIENT : TRANSMISSION CORPORATION OF ANDHRA PRADESH LIMITED		PROJECT NAME : AS APPLICABLE	
UNLESS OTHERWISE SPECIFIED			
1. ALL DIMENSIONS ARE IN mm			
2. TOLERANCE WHEREVER NOT INDICATED ±5%			
DATE	NAME	MATERIAL	
06.01.2021	SPS	AS ABOVE	
06.01.2021	AKASH		
06.01.2021	BIS		
SCALE:	N.T.S		
TITLE :			
GENERAL ARRANGEMENT DRAWING FOR 220KV CURRENT TRANSFORMER RATIO : 400-600-800/1A,5C BAR TYPE CT			
DRG.NO	MEHRU ELECTRICAL & MECHANICAL ENGINEERS (P) LTD.		
ME-220CT-GA-02			
REV.	REVISION DESCRIPTION	DATED INITIALS	
RO	FOR APPROVAL	06.01.2021	
SHEET No. 1 OF 7			

**MEHRU**

**LIVE TANK CURRENT TRANSFORMER**

MADE TO IS : 16227

HIGHEST SYSTEM VOLTAGE	245 kV	INSULATION LEVEL	460/1050 kV			
RATED S.T.C	40 kA for 1 Sec	RATED FREQUENCY	50Hz			
NOMINAL SYSTEM VOLTAGE	220 kV	CORE 1	CORE 2	CORE 3	CORE 4	CORE 5
RATIO	PRIMARY(Amp)	400-600-800	400-600-800	400-600-800	400-600-800	400-600-800
	SECONDARY (Amp)	1	1	1	1	1
SECONDARY TERMINALS	1S1-1S2-1S3-1S4	2S1-2S2-2S3-2S4	3S1-3S2-3S3-3S4	4S1-4S2-4S3-4S4	5S1-5S2-5S3-5S4	
RATED BURDEN	-----	-----	-----	-----	-----	20 VA
ACCURACY CLASS	PS	PS	PS	PS	PS	0.2S
ALF / ISF @ All taps	-----	-----	-----	-----	-----	≤5
Min Knee point voltage	400/600/800 V	400/600/800 V	400/600/800 V	400/600/800 V	400/600/800 V	-----
Max Rct at 75 DEG C	2.5/3.75/5.0 Ohms	2.5/3.75/5.0 Ohms	2.5/3.75/5.0 Ohms	2.5/3.75/5.0 Ohms	2.5/3.75/5.0 Ohms	-----
Max Rct at V <sub>k</sub> @ 800/1A	30mA	30mA	30mA	30mA	30mA	-----
Year OF MANUFACTURE	2021	SERIAL NO.				

\* RATED CONTINUOUS THERMAL CURRENT: 120% OF RATED PRIMARY CURRENT.  
 \* TOTAL WEIGHT OF CT : 940KGS. (APPROX.), QTY OF OIL: 225 LTRS. (APPROX)  
 \* TOTAL CREEPAGE DISTANCE :- 6125 mm. (MINIMUM)  
 MADE IN INDIA BY  
**MEHRU ELECTRICAL AND MECHANICAL ENGINEERS (P) LTD.**  
 SP2/180,RITCO INDUSTRIAL AREA,KEHRANI, BHIWADI - RAJASTHAN - 301019

**NOTES:-**

1. MATERIAL OF NAME PLATE : ANODIZED ALUMINUM
2. THICKNESS OF NAME PLATE : 1.2 mm.
3. SERIAL NO. SHALL BE ENGRAVE BEFORE DISPATCH.

- \* PRIMARY WINDING AREA : 1964 sq.mm
- \* CURRENT DENSITY : 0.49 A/sq.mm

Chief Engineer  
 Power Systems, Planning & Design  
 APTransco

**SUITABLE FOR HOT LINE WASHING**

**CONNECTION DIAGRAM**

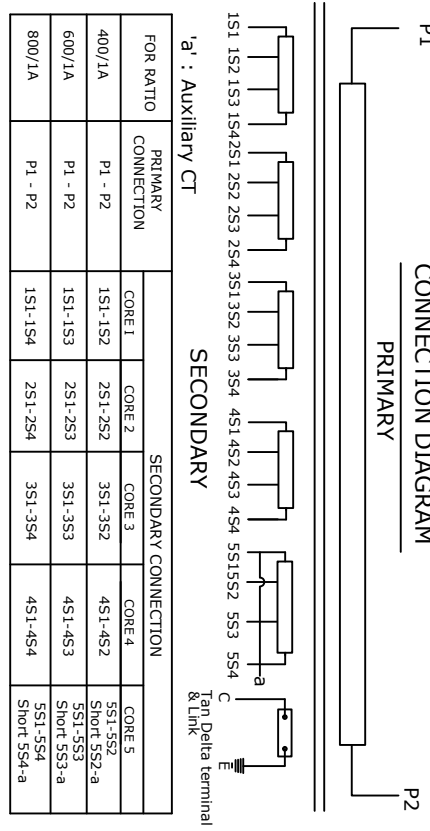

- CAUTION :-**
- I. Secondary terminals should be short circuited before the burden is disconnected.
  - II. Tan delta terminal 'C' must be short circuited when operation
  - III. Do not remove earth link when in operation

250 ±20

**NOTE : DRAWING APPROVAL SUBJECT TO VALID TYPE TEST REPORTS, TO BE CHECKED DURING ACCEPTANCE TESTS.**

Drawing approval subject to valid vendor registration

CLIENT : TRANSMISSION CORPORATION OF ANDHRA PRADESH LIMITED		PROJECT NAME : AS APPLICABLE	
UNLESS OTHERWISE SPECIFIED			
1. ALL DIMENSIONS ARE IN mm.	DGN.	06.01.2021	SFS
2. TOLERANCE WHEREVER NOT INDICATED ±5%	DRN.	06.01.2021	AKASH
	CHD.	06.01.2021	BLS
	SCALE:	N.T.S	
TITLE : NAME PLATE DRAWING FOR 220KV CURRENT TRANSFORMER RATIO : 400-600-800/1A,5C BAR TYPE CT			
SHEET No. 3 OF 7		DATED 06.01.2021	
FOR APPROVAL		REVISION DESCRIPTION	
REV.		INITIALS	

**MEHRU**

MEHRU ELECTRICAL & MECHANICAL ENGINEERS (P) LTD.



DRG.NO ME-220CT-NP-02

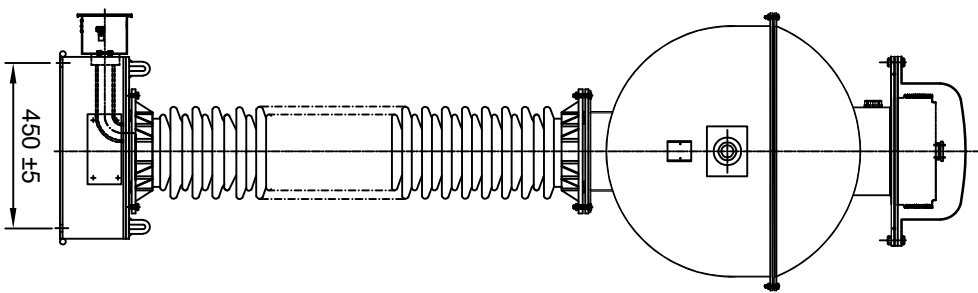
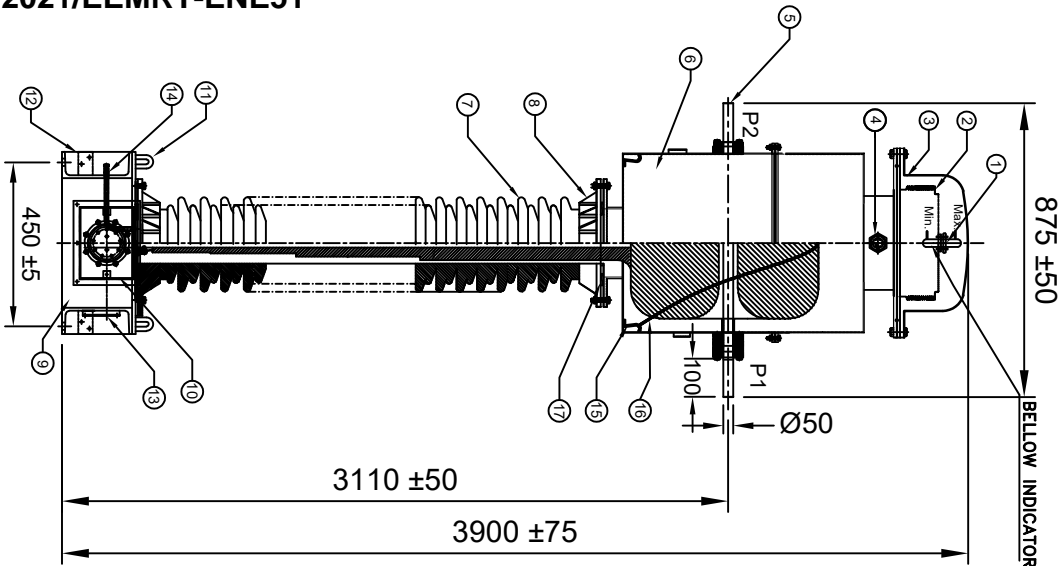
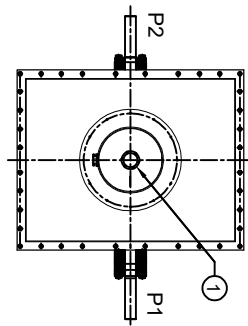

**NOTES :**

1. ALL FERROUS PARTS EXPOSED TO THE ATMOSPHERE SHALL BE PAINTED WITH P.U PAINT SHADE 631 OF IS: 5.
2. MAKE OF BUSHING: IEC/MODERN/BHEL/LAB/LC/JI
3. TOTAL CREEPAGE DISTANCE: - 6125 mm (MIN)
4. QUANTITY OF OIL: -225 LITRES APPROX.
5. TOTAL WEIGHT OF CT: 940 KGS APPROX.
6. PRIMARY WINDING SHALL BE BAR TYPE.
7. ALL GASKETS SHALL BE FIXED IN PROPERLY MACHINED GROOVES.
8. ALL HARDWARE SHALL BE HOT DIP GALVANIZED.
9. TRANSFORMER OIL AS PER IEC: 60296.
10. ALL GASKETS SHALL BE MADE OF NITRILE BUTYL RUBBER.
11. CORE/SECONDARY WINDINGS SHALL BE ENCASED IN ALUMINUM SHELL.

S.No.	DESCRIPTION	QTY	MATL
1	OIL FILLING PORT	1	M.S
2	BELLOW	1	S.S
3	BELLOW DOME	1	M.S/ALUMINIUM
4	OIL LEVEL INDICATOR	1	AL/BRASS
5	PRIMARY TERMINAL Ø50x100mm	1	ALUMINIUM
6	OIL TANK WITH COVER	1	M.S
7	BUSHING	1	PORCELAIN
8	BUSHING FLANGE (CEMENTED)	2	GICI
9	BASE	1	M.S.
10	SECONDARY TERMINAL BOX	1	M.S
11	LIFTING HOOK	4	M.S
12	EARTHING FLAT (80x50x8x Thick)	2	M.S
13	NAME AND RATING PLATE	1	ALUMINIUM ANODIZED
14	OIL DRAIN PLUG	1	M.S
15	HOOK FOR COIL TIGHTENING	4	M.S
16	COIL TIEING STRING	--	NYLON
17	BUSHING GASKET	2	NBR

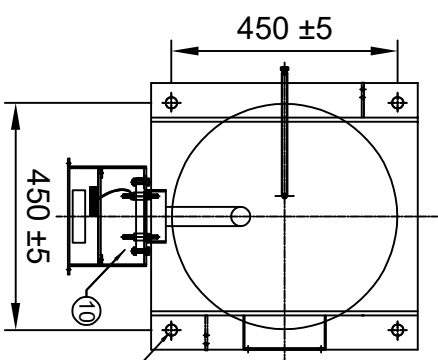

**MOUNTING DETAILS**

Chief Engineer  
Power Systems, Planning & Design  
APTRANSCO

CLIENT : TRANSMISSION CORPORATION OF ANDHRA PRADESH LIMITED			
PROJECT NAME : AS APPLICABLE			
UNLESS OTHERWISE SPECIFIED			
1. ALL DIMENSIONS ARE IN mm.			
2. TOLERANCE WHEREVER NOT INDICATED ±5%			
DGN.	DATE	NAME	MATERIAL
06.01.2021	06.01.2021	SPS	AS ABOVE
DRN.	DATE	AKASH	
06.01.2021	06.01.2021	BLS	
CHD.	SCALE:		
	N.T.S.		

REV.	FOR APPROVAL	06.01.2021	
	REVISION DESCRIPTION	INITIALS	

SHEET No. 2 OF 7

TITLE : SECTIONAL ARRANGEMENT DRAWING FOR 220KV CURRENT TRANSFORMER RATIO : 400-600-800/1A,5C BAR TYPE CT

MEHRU MECHANICAL & ELECTRICAL ENGINEERS (P) LTD.

MEHRU MECHANICAL & ELECTRICAL ENGINEERS (P) LTD.

DRG.NO ME-220CT-SE-02

Drawing approval subject to valid vendor registration

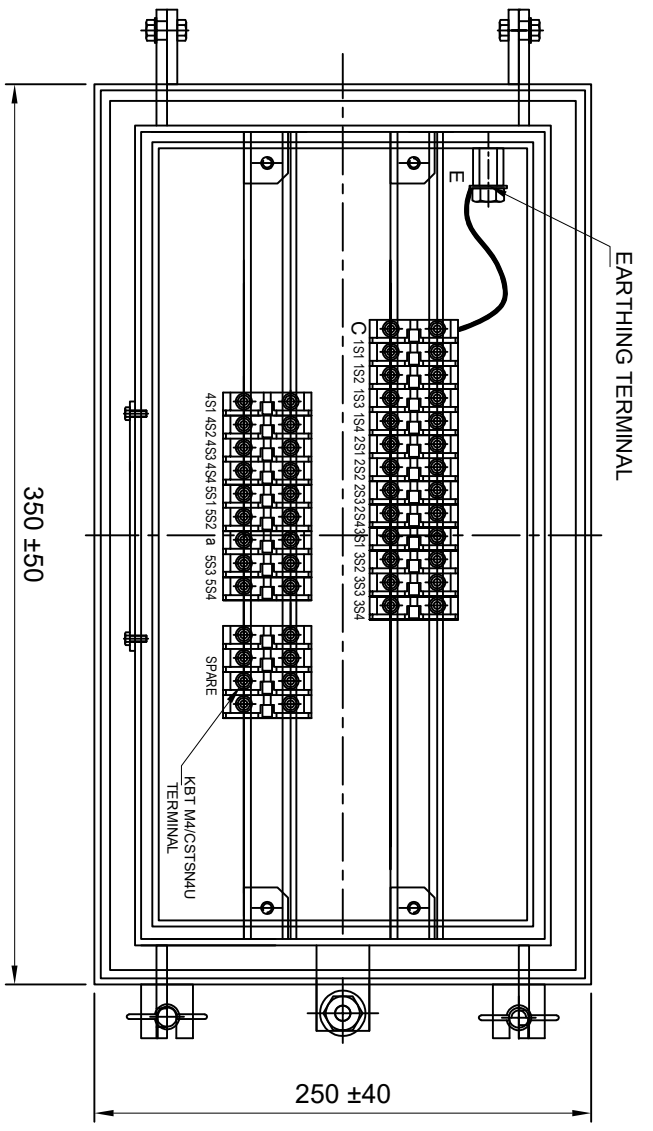

**FRONT VIEW**

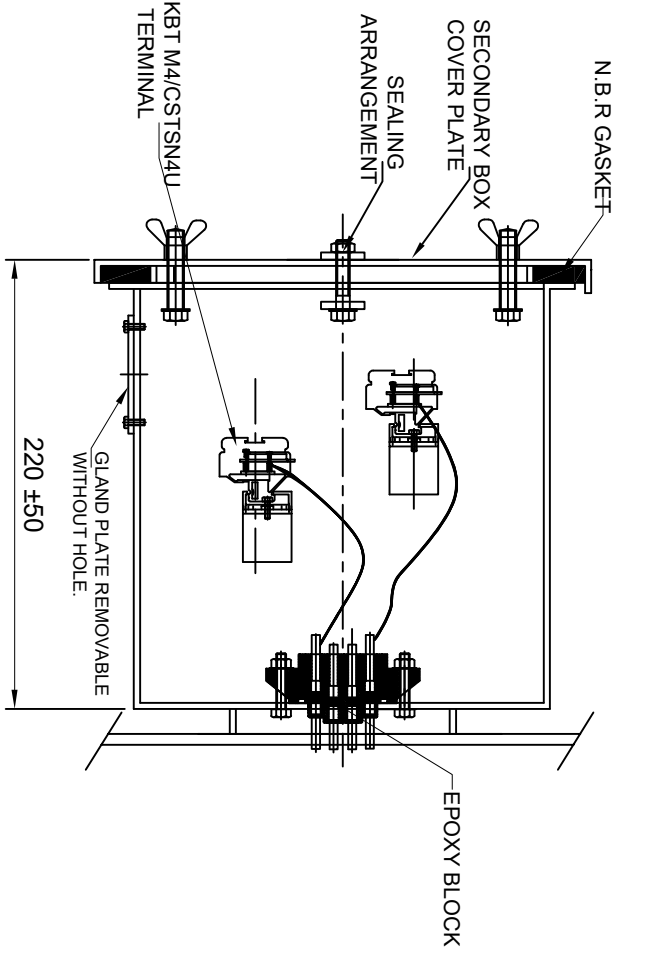

**SIDE VIEW**

'C' : TAN DELTA TESTING TERMINAL  
 'E' : EARTHING TERMINAL  
 'a' : AUXILIARY CT

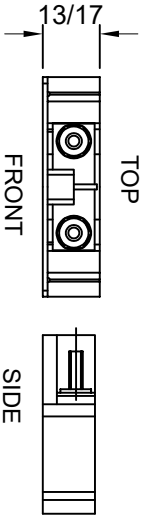
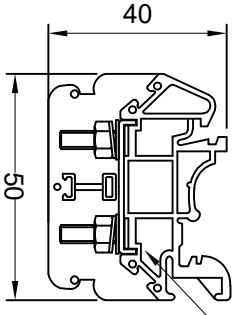

KBT M4/CSTSN4U TERMINAL

**NOTES:-**

1. SECONDARY TERMINAL BOX SHALL BE PROVIDED REMOVABLE GLAND PLATE WITHOUT HOLE.
2. SECONDARY TERMINAL BOX SHALL BE PROVIDED WITH COVER.
3. M.S SHEET THICKNESS FOR TERMINAL BOX 3.0mm. & FOR COVER 2.0 mm.
4. MATERIAL OF GASKET: NITRILE BUTYL RUBBER GASKET.
5. DEGREE OF PROTECTION : IP 55
6. 20% SPARE TERMINAL SHALL BE PROVIDED.

Drawing approval subject to valid vendor registration

MATERIAL: POLYAMIDE  
 MAKE: ELMEX/CONNECTWELL  
**TERMINAL (DETAIL)**

Chief Engineer  
 Power Systems, Planning & Design  
**APTransco**

REV	FOR APPROVAL	DATED
R0	06.01.2021	INITIALS
REV	REVISION DESCRIPTION	

CLIENT : TRANSMISSION CORPORATION OF ANDHRA PRADESH LIMITED			PROJECT NAME : AS APPLICABLE		
UNLESS OTHERWISE SPECIFIED					
1. ALL DIMENSIONS ARE IN mm.					
2. TOLERANCE WHEREVER NOT INDICATED ±5%					
DGN	DATE	NAME	MATERIAL		
DRN	06.01.2021	AKASH	M.S		
CHD	06.01.2021	BLS			
SCALE:	N.T.S				
TITLE :					
SECONDARY TERMINAL BOX DRAWING					
FOR 220KV CURRENT TRANSFORMER					
RATIO : 400-600-800/1A.5C					
BAR TYPE CT					
DRG.NO	MEHRU ELECTRICAL & MECHANICAL ENGINEERS (P) LTD.				MEHRU
ME-220CT-STB-02					

SHEET No. 4 OF 7

4609485/2021/EEMRT-ENE51

Guaranteed Technical Particulars for 220kV Current Transformer			
Sl. No.	Item Description	Unit	GTP as per Bid
<b>E</b>	<b>CURRENT TRANSFORMER</b>		
1	Make		Mehru Electrical & Mechanical Engineers (P) Ltd, Bhiwadi, (Raj), Inida
2	Type and Designation		Outdoor, Oil Cooled Live Tank Type, Current Transformer
3	Applicable standards		IS 16227
4	Class		A
5	Rated Voltage	220 kV	220 kV
6	Rated Primary current	Amps	400-600-800A
7	Rated Secondary current	Amps	1
8	Rated output (Burden)	VA	Core:-5: 20VA,
9	Rated output at 0.8 lag. p.f.	VA	N/A
10	Class of accuracy		Core:1,2,3 & 4 - PS, Core:-5: 0.2S
11	Accuracy limit factor		NA
12	Knee point voltage	Volts	Core-1,2,3,4 -400/600/800 V
13	CT Resistance of secondary winding corrected to 75 deg.C	Ohms	Core-1,2,3,4-2.5/3.75/5 Ohms
14	Magnetising current at knee-voltage point @highest tap	mA '	Core-1,2,3,4-30ma
15	secondary limiting voltage	kV	As per IS 16227
16	Instrument security factor for winding meant for metering		Core-5- ≤ 5 at all taps
17	One minute Power Frequency withstand test voltage of		
a)	Primary winding	kV (rms)	460
b)	Secondary winding	kV (rms)	3
18	Impulse withstand voltage of primary winding	kV (peak)	1050
19	One minute dry P.F. withstand voltage of primary winding	kV (rms)	460
20	Creepage distance	mm	25mm/kV i.e. 6125mm (Min.)
21	Rated continuous thermal current	Amps	120% of rated primary current
22	Ratios available at highest taps		Yes
23	Rated short time thermal current	kA (rms)	40 kA
24	Rated time for above	Sec.	1
25	Rated dynamic current for primary	kA (Peak)	100

Drawing approval subject to valid vendor registration

Chief Engineer  
Power Systems, Planning & Design  
APTransco

4609485/2021/EE/DR/ENE/50 ACCEPTANCE TESTS.

26	Class of insulation		A
27	Max. Temperature rise over ambient of 50 deg.C at any part of oil	deg.C	50c max
28			
a)	Radio interference voltage		As per IS 16227 Clause 6.11.2 <2500uV
b)	Partial discharge level		<10 pC at Um & <5 pc at 1.2Um/ <sup>3</sup>
30	Temp. rise after passing short time thermal current for one second	deg.C	50c max
31	Current density in primary winding at		
a)	Normal rating		0.49 Amp/sqmm
b)	Short time rating of 1 Sec.		20.4 Amp/sqmm
c)	Dynamic rating		50.9 Amp/sqmm
32	Type of primary winding		Aluminum
33	No. of primary turns		1
34	No. of secondary turns		400+200+200
35	Flux density at knee point		1.4 Tesla
36	Radio interference voltage	(micro volts)	
a)	with terminal connector mountd		<2500uV
b)	under test condition		<2500uV
37	Variation in ratio and phase angle error due to variation in		
a)	Voltage by 1%		N/A
b)	Frequency by 1 Hz.		N/A
38	Mounting details		450±5 x 450±5 mm
39	Source/grade of oil and standard with which it complies		EHV Grade Transformer Oil as per IS 335/IEC 60296 of any reputed make
40	Quantity of insulating oil	Litres	225 Ltr Approx
41	Weight of Oil	kg	180 kgs Approx
42	Total Weight including Oil	kg	940kG Approx
43	Overall dimensions (mm)		3900±75 x 875±50 x 450±5 mm
44	Wheather sealed (if so, type of sealing)		Yes, By SS BELLOW
45	Tan delta		<0.005
47	a) Weight of Steel		170.5 kgs (Approx.)
	b) Wight of Aluminum		25.3 kgs (Approx.)
	c) Weight of copper		22.2 kgs (Approx.)

NOTE : DRAWING APPROVAL SUBJECT TO VALID TYPE TEST REPORTS, TO BE CHECKED DURING ACCEPTANCE TESTS.

Since the supply of terminal connectors is not in the scope of manufacturer as mentioned in the drawings, the EPC contractors shall be instructed to supply the same in line with CT/VT/CVT requirement and compatibility.

**FOR EPC CONTRACTS ONLY**