

NOTE: 1. Drawings Approval subject to valid type test reports, to be checked during acceptance tests.

2.For EPC contractors only.

245 KV CURRENT TRANSFORMER TYPE: IMB 245 (25mm/kV)

CLIENT:
(AS APPLICABLE)

Drawing approval subject to valid vendor registration

END CUSTOMER:
APTRANSCO

W.O. NO.:
(AS APPLICABLE)

PROJECT:
(AS APPLICABLE)

**CHIEF ENGINEER/PROJECTS
APTRANSCO/VISVIJAYAWADA**

P.O. NO.:
(AS APPLICABLE)

QTY:
(AS APPLICABLE)

CT RATIO:
1600-800-500/1-1-1-1, 1600-800-500-300/1

SR. NO.	REFERENCE OF STD DRGS/ DOCUMENTS	REV.	DESCRIPTION
1.	1HYT903320-113	A	GENERAL ARRANGEMENT
2.	1HYT903320-114	B	RATING PLATE
3.	1HYT903320-115	B	SECONDARY TERMINAL BOX
4.	1HYT903320-116	A	INSULATOR (25 mm/kV)

We reserve all rights in this document and in the information contained there in reproduction, use or disclosure to third parties without express authority is strictly forbidden ©HITACHI ENERGY INDIA LIMITED.

Ⓐ New drg. prepared.

Ⓑ Change in sr no. 2,3

This drawing is a COMPUTER ORIGINAL and does not require signature for its authentication

Prepared: SR	Checked: PDS	Approved: SN
Without Sep. PL: <input type="checkbox"/>	Same PL.Same No.: <input type="checkbox"/>	Sep. PL.Other No.: <input type="checkbox"/>
Derived by:	Supersedes:	Supersedes by:
A 2023-07-10		
B 2023-07-31		

LIST OF DOCUMENTS FOR IMB 245 TYPE CT

HITACHI ENERGY INDIA LIMITED

1HYT903320-112



Scale NTS

T.Sh. 1

Sheets 1

This document is COMPUTER ORIGINAL and does not need signature for its authentication

NOTE: 1. Drawings Approval subject to valid type test reports, to be checked during acceptance tests.
2. For EPC contractors only.

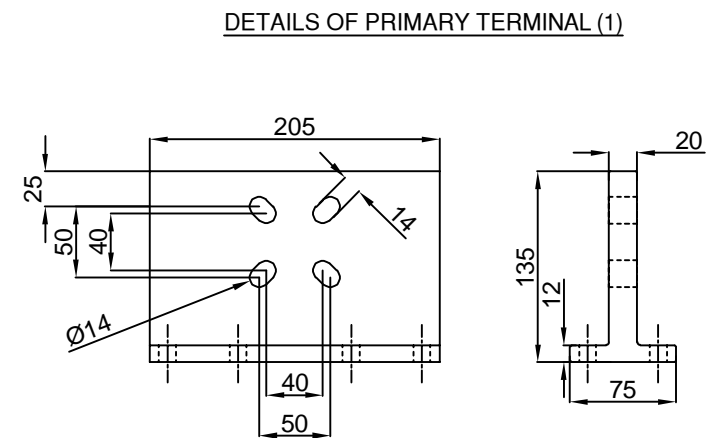
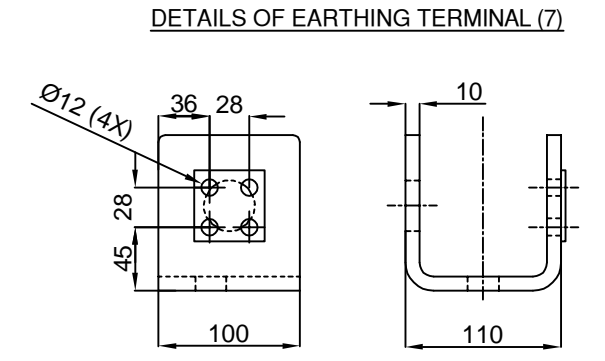
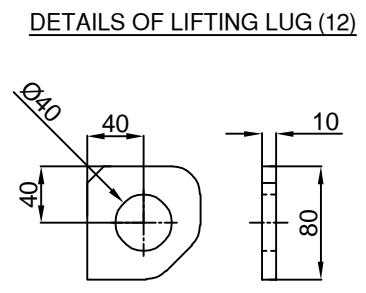
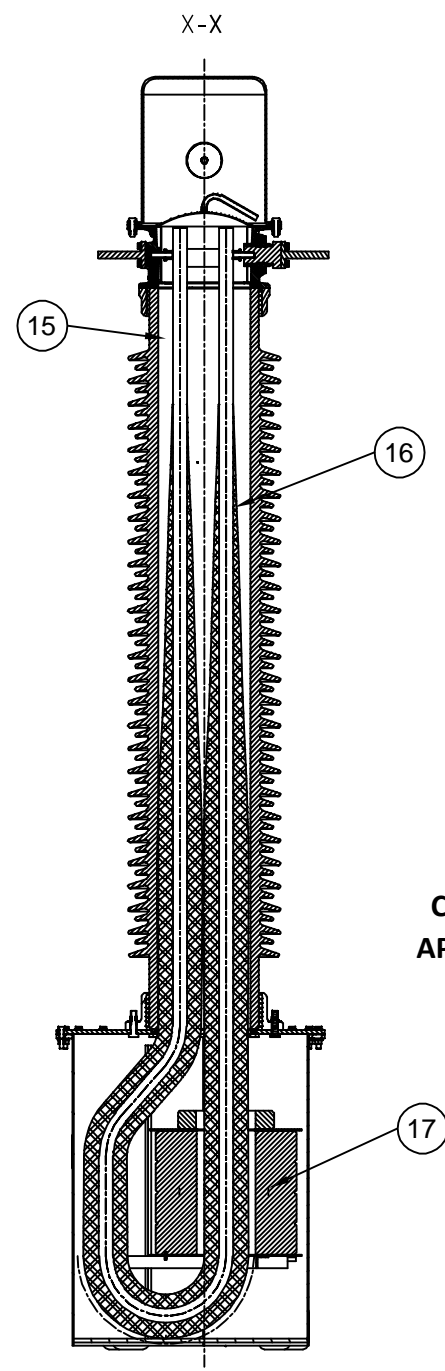
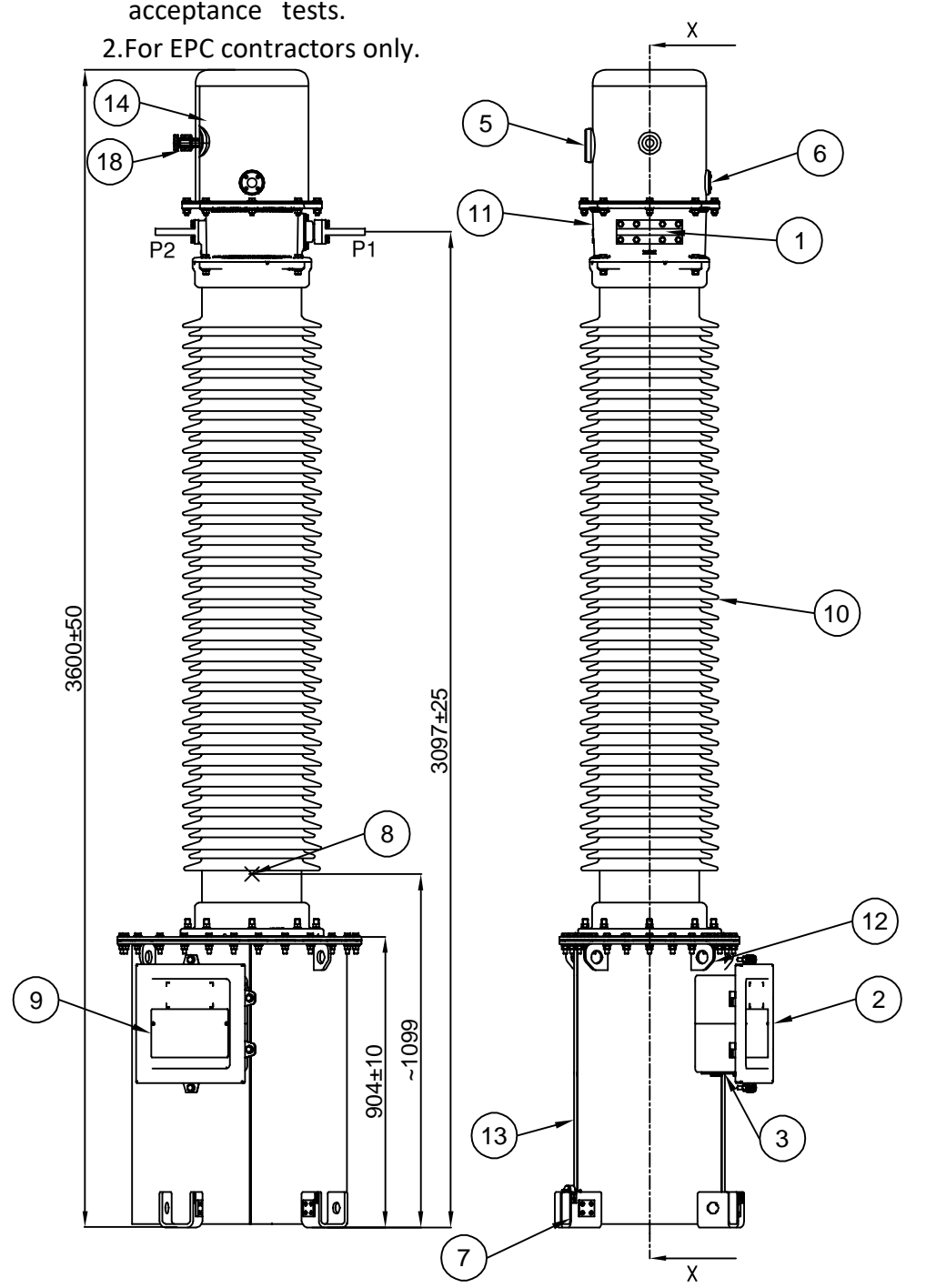

**CHIEF ENGINEER/PROJECTS
APTRANSCO/VS/VIJAYAWADA**

*HOT DIP GALVANISED ON OUTER SURFACE & PAINTED ON INNER SURFACE
INNER SURFACE PAINTED WITH OIL RESISTIVE PAINT

18	PRESSURE RELEASE DEVICE	-	SS / BRASS
17	CORE STACK	-	-
16	PRIMARY WINDING	-	PRIMARY CONDUCTOR (ALU)
15	TRANSFORMER OIL	~150kg	EHV GRADE - IEC:60296
14	OIL EXPANSION SYSTEM	1	TANK - ALU. EXP. SYSTEM - N2 GAS.
13	BOTTOM TANK AND TANK COVER	1	M.S HDG*
12	LIFTING LUG	4	M.S HDG*
11	CONNECTION HEAD	1	ALU.
10	INSULATOR	1	PORCELAIN
9	NAME PLATE	1	ALU.
8	CENTRE OF GRAVITY	-	-
7	EARTH CLAMP	4	S.S. WELDED OVER M.S.
6	OIL LEVEL INDICATOR	1	TOUGHENED GLASS
5	OIL FILLING COVER	1	ALU.
4	OIL DRAIN PLUG WITH BLANKING PLATE	1	M.S HDG*
3	REMOVABLE UNDRILLED GLAND PLATE	1	M.S HDG*
2	SECONDARY TERMINAL BOX	1	M.S HDG*
1	PRIMARY TERMINAL	2	ALU.
Sr. No.	Item Description	Qty.	Material

NOTES:

- 1) DEVIATION FOR DIMENSIONS WITHOUT SPECIFIED TOLERANCES AS PER IS: 2102 - (EXTRA COARSE).
- 2) ALL NUTS, BOLTS AND WASHERS ARE OF STAINLESS STEEL/ MS HOT DIP GALVANIZED
- 3) ALL DIMENSIONS ARE IN mm.
- 4) TOTAL WEIGHT 1150 kg approx.
- 5) CREEPAGE DISTANCE 6125 mm.
- 6) ALL FERROUS PARTS EXPOSED TO ATMOSPHERE ARE HOT DIP GALVANIZED.
- 7) GENERAL TOLERANCE AS PER IS:2768-C

Revision Details:
A) New drg. prepared.

We reserve all rights in this document and in the information contained therein. Reproduction, use or disclosure to third parties without express authority is strictly forbidden. © HITACHI ENERGY INDIA LIMITED

Revision		245 kV OUTDOOR CURRENT TRANSFORMER TYPE IMB 245	GENERAL ARRANGEMENT DRAWING (Medium Tank)	Prepared: SR	Checked: SNP	Approved: SN	file: 3320-113	Total sh. 1
A	2023-07-10			HITACHI ENERGY INDIA LIMITED			1HYT903320-113	Sh.No. 1

NOTE: 1. Drawings Approval subject to valid type test reports, to be checked during acceptance tests.
2.For EPC contractors only.

This drawing is a COMPUTER ORIGINAL and does not require signatures for its authentication

Revision Details:
(B) 5S2A, 5S2 nomenclature provided instead of 5S2, 5S3

Revision Details:
(A) New drg prepared.

We reserve all rights in this document and in the information contained there in. Reproduction, use or disclosure to third parties without express authority is strictly forbidden.
© HITACHI ENERGY INDIA LIMITED

250

Current transformer HITACHI ENERGY INDIA LIMITED Production year - YYYY Made in India

Serial number	nnnnnnn	Type	IMB 245	Frequency	50 Hz
Insulation level	245/460/1050	Standard	IEC: 61869-1,2	Temperature range	-5 to +50 °C
Rated pri. normal current	1600A	Total mass(Approx)	1150 kg	Total creepage minimum	6125 mm
Max continous primary current	1920A	Insulation oil(Approx)	150 kg	lth	40/1 kA/s
GA Drawing	1HYT903320-113	Suitable for Hot line washing	Yes	ldyn	100 kAp

P1

P2

RATIO	1600/1	800/1	500/1	300/1	
CORE-1	1S1-1S4	1S1-1S3	1S1-1S2	-	AUX. REACTOR CONNECTION DETAIL FOR CORE 5 ONLY 1.CONNECT SHORTING LINK BETWEEN 1X1-5S1 & 1X2-5S4, 5S3,5S2 & 5S2A FOR THE RATIO OF 1600/1,800/1,500/1 & 300/1 RESPECTIVELY. TAKE OUTPUT FROM 1X1-1X2 . 2.DO NOT CONNECT SHORTING LINK FOR THE RATIO OF _____.
CORE-2	2S1-2S4	2S1-2S3	2S1-2S2	-	
CORE-3	3S1-3S4	3S1-3S3	3S1-3S2	-	
CORE-4	4S1-4S4	4S1-4S3	4S1-4S2	-	
CORE-5	5S1-5S4	5S1-5S3	5S1-5S2	5S1-5S2A	
CORE	CORE-1	CORE-2	CORE-3	CORE-4	CORE-5
I A	1600-800-500/1	1600-800-500/1	1600-800-500/1	1600-800-500/1	1600-800-500-300/1
Vk V/ B VA	>1600/800/500	>1600/800/500	>1600/800/500	>1600/800/500	10
CI	PX	PX	PX	PX	0.2S
ISF/ALF	-	-	-	-	<5
Io mA	<25/50/80 at Vk	<25/50/80 at Vk	<25/50/80 at Vk	<25/50/80 at Vk	-
Rct Ω	<8/4/2.5	<8/4/2.5	<8/4/2.5	<8/4/2.5	-

END CUSTOMER: APTRANSCO

HITACHI ENERGY INDIA LIMITED WORKS ORDER NO: _____

(AS APPLICABLE)

CLIENT WORK ORDER NO: (AS APPLICABLE) _____

PROJECT: (AS APPLICABLE) _____

Caution 1)Ensure D3(Tan Delta) Bushing connection with Earth
2)Secondary terminals must be short circuited before burden is disconnected

Serial number nnnnnnn to be decided when manufactured
 Production year yyyy = Actual year, date & month of Production
 Material: Aluminum 2mm Thk.
 Letter height 3 mm

CHIEF ENGINEER/PROJECTS
APTRANSCO/VS/VIJAYAWADA

Revision		245 kV OUTDOOR CURRENT TRANSFORMER TYPE IMB 245	RATING PLATE	Prepared: SR	Checked: PDS	Approved: SN	File: 3320-114	Total sh. 1
A	2023-07-10			HITACHI ENERGY INDIA LIMITED			1HYT903320-114	Sh.No. 1
B	2023-07-31							

This document is COMPUTER ORIGINAL and does not need signature for its authentication

NOTE: 1. Drawings Approval subject to valid type test reports, to be checked during acceptance tests.
2. For EPC contractors only.

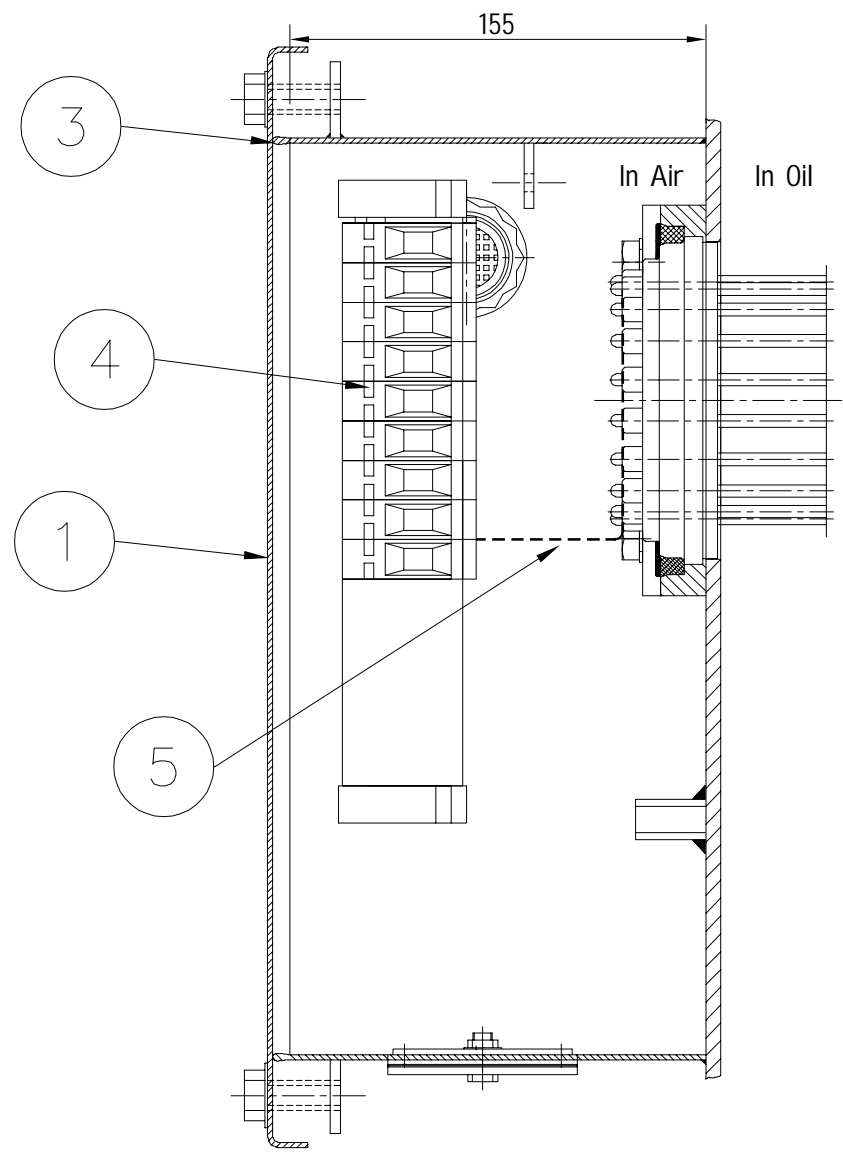

Section-AA

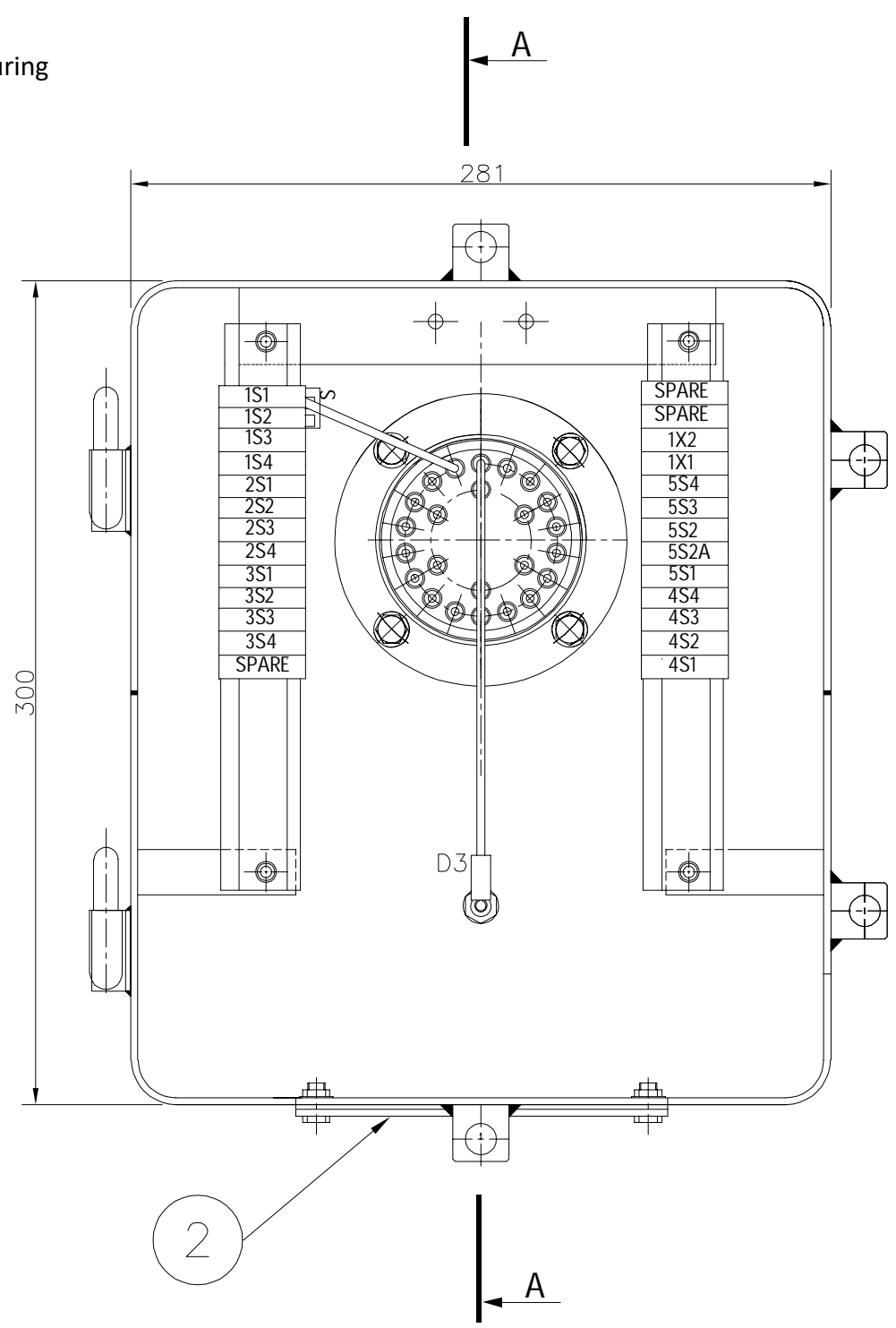

D3= Tan δ measuring terminal

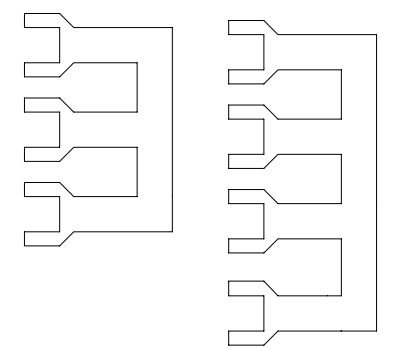

S-Shorting link

AUX. REACTOR CONNECTION WITH CORE 5 (METERING)

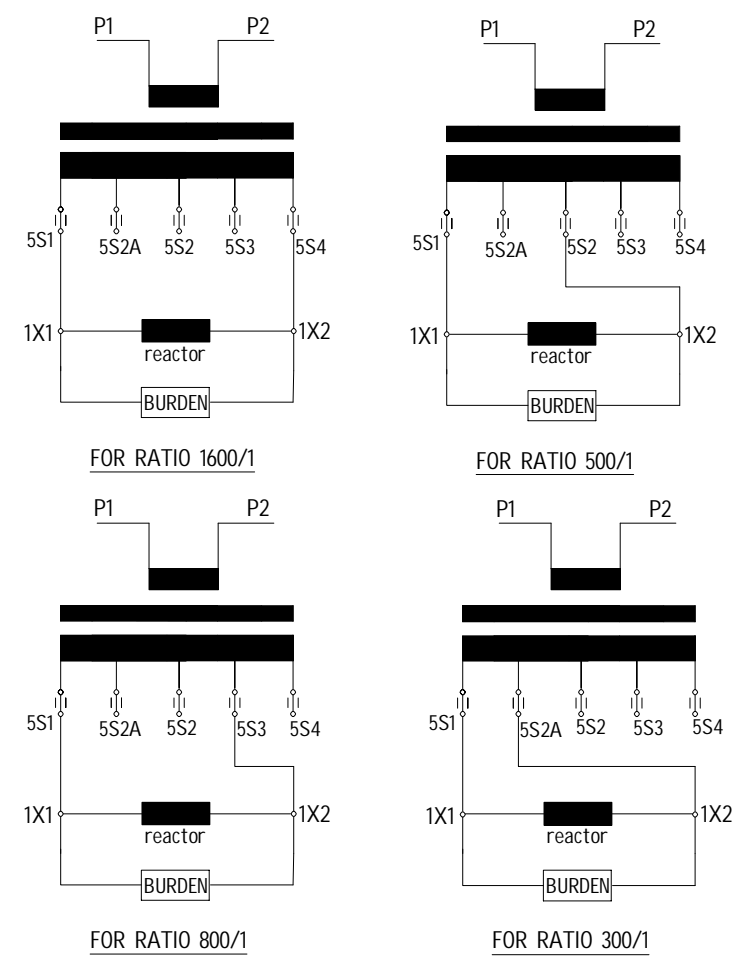

Drawing approval subject to valid vendor registration

NOTES : -

- 1) DEGREE OF PROTECTION IP 55
- 2) THE SECONDARY TERMINAL BOX IS HOT DIP GALVANISED
- 3) D3 TERMINAL IS FOR THE MEASUREMENT OF POWER FACTOR AND LOSS ANGLE
- 4) THE BOX IS SUITABLE FOR ACCOMMODATING SECONDARY CABLES OF 1100 V
- 5) STEEL SHEET 3.15 mm THICK HOT ROLLED
- 6) ALL DIMENSIONS ARE IN mm. GENERAL TOLERANCE AS PER ISO: 2768-c
- 7) NO. OF WIRES SHOWN IN THE TERMINAL BLOCK ARE INDICATIVE ONLY

**CHIEF ENGINEER/PROJECTS
APTRANSCO/VSI/VIJAYAWADA**

5	COPPER WIRE
4	SERIES TERMINAL STUD TYPE
3	EPDM GASKET
2	UNDRILLED GLAND PLATE (3mm Thk.)
1	COVER
SR NO.	ITEM DESCRIPTION

Revision Details:
B 5S2A,5S2 nomenclature provided instead of 5S2,5S3

Revision Details:
A New Drawing prepared

We reserve all rights in this document and in the information contained therein. Reproduction, use or disclosure to third parties without express authority is strictly forbidden.
© HITACHI ENERGY INDIA LIMITED

Revision		CURRENT TRANSFORMER	DRAWN:	CHECKED:	APPRD.:	file: 3320-115	TOTAL SH.
A	2023-07-10	TYPE : IMB 245	SR	PDS	SN	1HYT903320-115	1
B	2023-07-31	SEC. TERMINAL BOX : DETAILS	HITACHI ENERGY INDIA LIMITED				Sh. NO.

This document is COMPUTER ORIGINAL and does not need signature for its authentication

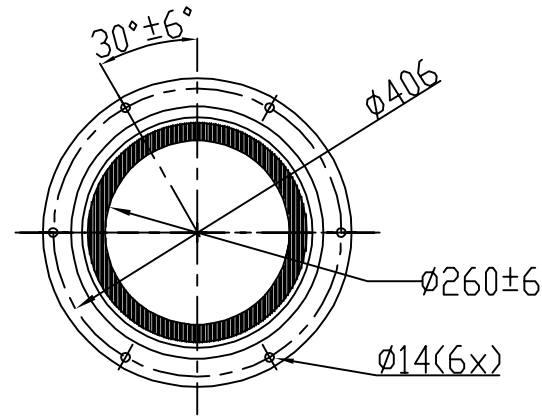

BOTTOM VIEW

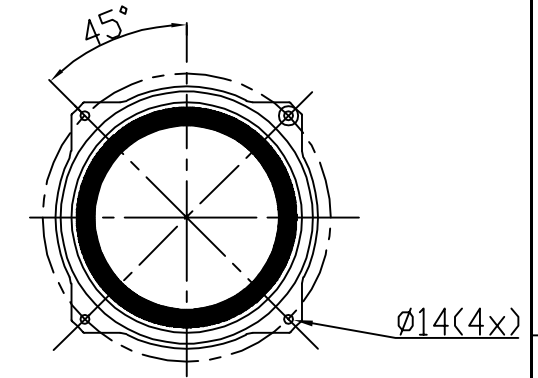
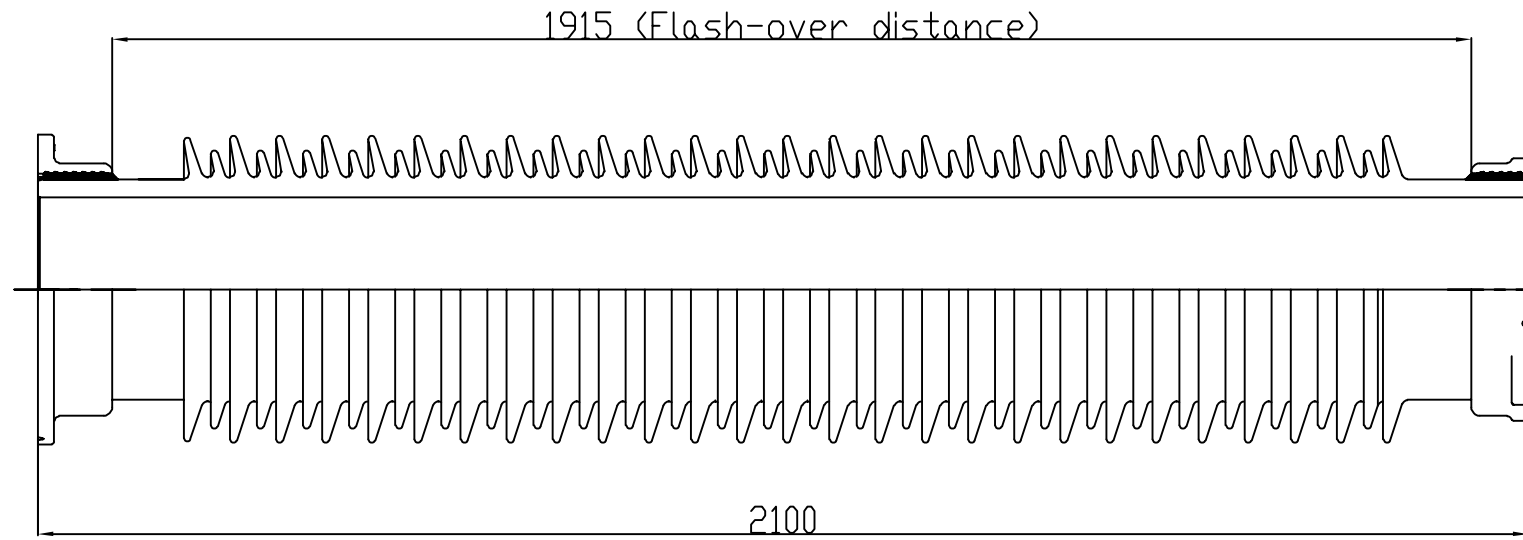

TOP VIEW

NOTE: 1. Drawings Approval subject to valid type test reports, to be checked during acceptance tests.
2. For EPC contractors only.

1. Minimum 300mm plinth shall be maintained for CT/PT/CVT/Isolators/IV/LA/Breakers in the substation during foundation works to ensure safe live to ground clearance per IE rules.
2. Since the supply of terminal connectors is not in the scope of manufacturer as mentioned in the drawings. The EPC contractor shall be instructed to supply the same line with CT/PT/CVT/Isolator/IVT/LA/Breaker's requirement and compatibility.

Shed profile

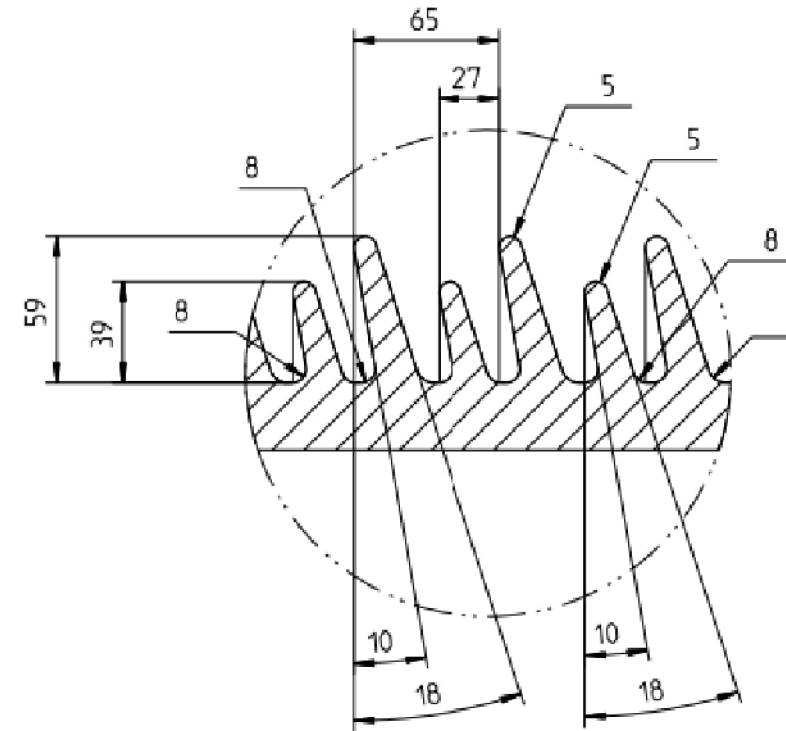

27 long and 26 short sheds

CHIEF ENGINEER/PROJECTS
APTRANSCO/VISVIJAYAWADA

NOTE: -

- 1) TOTAL CREEPAGE LENGTH 6125 mm nominal
- 2) OVALITY, BENDING, ECCENTRICITY, ETC. SHOULD HAVE TOLERANCES AS PER IS: 5621.
- 3) GENERAL TOLERANCES UNLESS OTHERWISE SPECIFIED: ±3%
- 4) LONG & SHORT SHED PROFILE AS PER IEC:60815

ALL DIMENSIONS ARE IN mm. GENERAL TOLERANCE AS PER ISO: 2768-c

Drawing approval subject to valid vendor registration

We reserve all rights in this document and in the information contained there in. Reproduction, use or disclosure to third parties without express authority is strictly forbidden. © HITACHI ENERGY INDIA LIMITED

Revision		245 kV OUTDOOR CURRENT TRANSFORMER TYPE IMB 245	INSULATOR DRAWING	Prepared: SR	Checked: PDS	Approved: SN	file: 3320-116	Total sh. 1
A	2023-07-10			HITACHI ENERGY INDIA LIMITED			1HYT903320-116	Sh.No. 1

NOTE: 1. Drawings Approval subject to valid type test reports, to be checked during acceptance tests.

2. For EPC contractors only.

HITACHI
Inspire the Next

Annexure-A

GUARANTEED TECHNICAL PARTICULARS FOR

CURRENT TRANSFORMERS (245kV CT: 1600-800-500/1-1-1-1, 1600-800-500-300/1 A)

1	Type of tank/Installation Dead/Live Tank Type	Dead tank, Single phase, Oil Filled, Outdoor Type
2	Type of mounting	Pedestal Mounting
3	Manufacturer's Name and address and Country of Manufacture	Hitachi Energy India Ltd (Formerly - APPSIL) Maneja, Vadodara – 390013 India
4	Whether Conforming to IEC 61869 standard	Yes
5 a) i)	Primary and Secondary winding made out of	Primary – Aluminum, Secondary – Copper
ii)	Primary windings -Design density for short circuit current -Conductivity of metal used -	Aluminum - 19.37 Amp/mm ² (approx.) - As per IEC
b) i)	Area of cross section of primary winding	2065 mm ² (approx.)
ii)	Area of cross section of secondary winding	PX : 1.17 mm ² (approx.) Metering: 1.41 mm ² (approx.)
c)	Material used for providing secondary terminals	Brass (Primary Terminal will be Al)
d)	Material used for providing secondary terminals	Brass
e)	Whether Primary is Rigid Bar type in case of live tank	Not applicable
6	Rated primary voltage (kV rms)	220 KV / root3
7	Rated highest voltage (kV rms)	245 KV
8	Rated frequency (Hz)	50 Hz
9	Rated primary current (A)	1600-800-500 (Core – 1,2,3,4) & 1600-800-500-300 (Core – 5)
10	Rated secondary current (A)	1
11	Ratio taps (on secondary side only)	On Secondary Side
12	Type of insulation	Class A
13	Seismic acceleration (g)	0.3 g vertical
14	RIV at 1.1 x Rated voltage (mv)	< 1000 micro volts
15	Tank material and Tank coating	Mild Steel, HDG
16	Hardware exposed to atmosphere	HDG
17	Bolts, Nuts and Washers	MS Hot dip galvanized.
18	Porcelain housing and it make (Single piece only)	Hollow type, IEC/BHEL/ABIL/ADI/Modern or Equivalent Make
19	Sealing (Nitrogen gas cushion/Metal bellow)	Nitrogen cushion
20	Instrument security factor	<5 (For Metering core only)
21	Whether Tan Delta test tap provided	Yes
22	Whether secondary terminal plate is of molded epoxy resin type	Yes
23	Whether primary terminal bushings are of molded Epoxy cast resin/Glass fiber reinforced Polymer	Molded cast resin & Porcelain
24	Whether all seals are of "O" ring type	Yes "O" ring & Flat gasket

CHIEF ENGINEER/PROJECTS
APTRANSCO/VS/VIJAYAWADA

7754016/2023/EEMRT-ENE51
NOTE: 1. Drawings Approval subject to valid type test reports, to be checked during acceptance tests.

2.For EPC contractors only.

HITACHI
Inspire the Next

25	Whether all "O" Rings are fixed in machined grooves with adequate space for compression'	Yes				
26	Whether the main hollow insulator has the flanges cemented at both ends	Yes				
27	Whether "O" Rings are of Nitrile butyl rubber or Viton	Yes (NBR)				
28	Whether the Short circuit Ampere-turns of the CT being supplied is same as type tested CTs	Yes	CHIEF ENGINEER/PROJECTS APTRANSCO/VISVIJAYAWADA			
29	Tan Delta	Shall be less than 0.350%				
30	Whether ratio selection is achieved only in secondary	Yes				
31	Whether ratio selection is achieved only in secondary	Yes				
32	Whether Non return drain valve for oil sampling is arranged for 132kV and above CT/IVT	Bolt Type				
33	Acceptable limit of temperature	As per IS/IEC				
34	Partial Discharge Level	< 5 at Um x 1.2/√3, < 10 at Um (where Um is highest system voltage)				
35	Rated short time withstand current for 1 sec. duration (kA rms)	40 kA				
36	Rated dynamic withstand current (kAp)	100 kA				
37	Rated continuous thermal current (pu) where pu = rated current	120% of rated primary current				
38	1.2/50 micro second impulse withstand voltage (kVp)	1050				
39	One minute power frequency withstand voltage (kV rms) of primary winding (Dry)	460				
40	One minute power frequency withstand voltage of secondary winding (kV rms)	3				
41. a)	Minimum total creepage distance of insulator bushing (mm)	6125mm (25mm/kV) Porcelain Insulator				
b)	Protected creepage of distance of bushing (mm)	Not Applicable				
42	Details of Cores	Core-I	Core-II	Core-III	Core-IV	Core-V
42.1	Current Ratios A/A	1600-800-500/1	1600-800-500/1	1600-800-500/1	1600-800-500/1	1600-800-500-300/1
42.2	Output burden (VA)	-	-	-	-	10
42.3	Class of accuracy	PX	PX	PX	PX	0.2S
42.4	Accuracy limit factor / ISF	-	-	-	-	<5
42.5	Min. knee point voltage (kVp) in volts	>1600-800-500	>1600-800-500	>1600-800-500	>1600-800-500	
42.6	Secondary resistance corrected to 75 deg.C in ohms	<8/4/2.5	<8/4/2.5	<8/4/2.5	<8/4/2.5	

Drawing approval subject to valid vendor registration

NOTE: 1. Drawing Approval subject to valid type test reports, to be checked during acceptance tests.

2. For EPC contractors only.

HITACHI
Inspire the Next

42.7	Max. Exciting current (mA) at 100% of Knee Point Voltage (Vk)	<25/50/80	<25/50/80	<25/50/80	<25/50/80	-
42.8	Application	Protection	Protection	Protection	Protection	Metering
43	Weight of oil (Kg.)	150 Kg (approx.)				
44	Approximate weight of copper used (Kgs)	37 Kg.				
45	Approximate weight of Steel used (Kgs)	220 kg.				
46	Total Weight (Kg.)	1150 kG. (approx.)				
47	Mounting details	450x450 (Please refer GA enclosed)				
48	Overall dimensions	Please refer GA drawing enclosed				
49	Characteristics (whether graphs enclosed):					
a)	Ratio and phase angle curves	NA				
b)	Magnetization curves	NA				
c)	Ratio correction factor curves	NA				
50	Core					
a)	Area of cross section (sq.cm.)	-				
b)	Flux density at rated primary current and rated burden	As per Standard design practice				
c)	Grade	M4 (Or equivalent) For PX Core Nano Core For Metering Core				

Drawing approval subject to valid vendor registration

CHIEF ENGINEER/PROJECTS
APTRANSCO/VIS/VIJAYAWADA

1. Minimum 300mm plinth shall be maintained for CT/PT/CVT/Isolators/IV/LA/Breakers in the substation during foundation works to ensure safe live to ground clearance per IE rules.
2. Since the supply of terminal connectors is not in the scope of manufacturer as mentioned in the drawings. The EPC contractor shall be instructed to supply the same line with CT/PT/CVT/Isolator/IVT/LA/Breaker's requirement and compatibility.