

7433670/2023/EEMRT-ENE5 PAVANI POWER SYSTEMS PVT. LTD.,



TRANSMISSION CORPORATION OF ANDHRA PRADESH LTD.

GUARANTEED TECHNICAL PARTICULARS FOR 36kV 1200A DB ISOLATORS

S.No	Item	Guaranteed value
1	Type / Installation	"DBR' Double Break Center post rotating type" / Outdoor installation
2	Manufacturer's Name and Country of Manufacture	PAVANI POWR SYSYEM PVT LTD. INDIA
3	Standards according to which the isolators are manufactured	IS: 9921 - Part-I to V / IEC:62271-102
4	Miximum design voltage at which the isolator can operate (kV)	36
5	Frequency (Hz)	50
6	Rated voltage (kV)	33
7	Maximum current that can be safely interrupted by the isolator Inductive (A & % PF) Capacitive (A & % PF)	Inductive- 0.7 Amps at 0.15 p.f. Capacitive- 0.7 Amps at 0.15 p.f.
8	Continuous current rating Nominal (Amps) under site conditions	1200
9	Rated short time current	MAIN SWITCH
	i) For 3 seconds (kA rms)	31.5KA 3.Sec.
	ii) For 1 second (kA rms)	Not Applicable
	iii) Rated peak short time current (kVp)	78.75
10	Current density at the minimum cross-section of	Contact sizes indicated in Annexure - III of specification & as per the property of materials.
	a) Moving blade (Amps/ Sq.mm) Cu. Tube	2.0 Amps / Sq.mm for HDE Cu. Tube
	b) Terminal pad : Aluminum Flat	1.0 Amp/ Sq.mm for EC grade Alu. Flat
	c) Contacts : Cu.Flat	1.6 Amps/Sq.mm for HDE Cu. Flat
	d) Terminal connector : Aluminm Casting	1.0 Amps/Sq.mm for Alu. Alloy.
11	Maximum Temp. Rise of current carrying parts when carrying rated current continuously (deg.C)	Within the specified limits of IS: 9921 - PartII/ IEC-62271-102
12	Insulation Levels	:
	i) Impulse withstand voltage (kV peak) phase to earth across isolating distance:	170/ 195 kV peak
	ii) Switching surge withstand voltage (kV peak) phase to earth across isolating distance	Not applicable
	iii) Power frequency withstand voltage (kV rms) Phase to earth isolating distance	70/ 80 kV rms
13	Minimum clearance in air	:
	i) Between poles (mm)	Phase spacing of 1300 mm
	ii) Between live parts and earth (mm)	450mm (Equal to dry arcing distance of insulators selected)
	iii) Between live parts when switch is open	:
	a) On the same pole (mm)	900
	b) Between adjacent poles (mm)	1300

NOTE : DRAWING APPROVAL SUBJECT TO VALID TYPE TEST REPORTS, TO BE CHECKED DURING ACCEPTANCE TESTS.



TRANSMISSION CORPORATION OF ANDHRA PRADESH LTD.

GUARANTEED TECHNICAL PARTICULARS FOR 36KV 1200A DB ISOLATORS

S.No	Item	Guaranteed value
14	Rated mechanical terminal load	:
	i) Load along the terminal connector side (Kg.)	: Not applicable (As per IS / IEC)
	ii) Load across the terminal connector side (Kg.)	: Not applicable (As per IS / IEC)
16	Torque required to operated the switch in Kg.m	: 36
17	Design and Construction	:
	i) No. of insulators per pole	: Three
	ii) No. of breaks per pole	: Two
	iii) Type of closing / opening mechanism (Horizontal/Vertical break straight etc.)	: Horizontal double break isolator
	iv) Contacts	:
	a) Material and grade	: Hard drawn electrolytic copper flat, contact area is silver plated (15 Microns)
	b) Cross-sectional area (mm)	: 768 sq.mm for 1200 Amps
	v) Moving blades	:
	a) Material and grade	: Hard drawn electrolytic copper flat, contact area is silver plated (15 Microns)
	b) Cross-sectional area (mm)	: 643 sq.mm for 1200 Amps
	vi) Contact support	:
	a) Material and size of channel/block	: 4 mm thick, MS HDG
	b) Material and size of plate	: 6 mm thick, MS HDG Plate
	vii) Rain hood - Material grade and size	: 1mm GI Sheet
	viii) Bang Type mechanism	:
	a) Material and size of clamps	: 6 mm thick, M.S. flat (HDG)
	b) Maerial size of springs	: Not applicable
	c) Whether springs are encased	: Not applicable
	ix) Nuts and Bolts	:
	a) Size, material and grade in live parts	: Less than M12: Stainless steel
	b) Size, material and grade in other parts	: M12 and above: MS HDG.
	x) Insulator base plate material and size of plate below insulators	: 6 mm MS Hot dip galvanised plate
	xi) Bearings	:
	a) Material and size of housing	: MS HDG suitable for 25 ID taper roller/ ball bearing.
	b) No. of bearings, location and size	: 2 Nos . Below centre rotating post insulator.

NOTE : DRAWING APPROVAL SUBJECT TO VALID TYPE TEST REPORTS, TO BE

CHECKED DURING ACCEPTANCE TESTS.

1) Minimum 300mm plinth shall be maintained for CT/PT/CVT/Isolators in the substation during foundation works to ensure safe live to ground clearances as per IE rules.

2) Since the supply of terminal connectors is not in the scope of manufacturer as mentioned in the drawings, the EPC contractors shall be instructed to supply the same in line with CT/PT/CVT/Isolators requirement and compatibility.

Chief Engineer (Projects)

Drawing approval subject to valid vendor registration



TRANSMISSION CORPORATION OF ANDHRA PRADESH LTD.

GUARANTEED TECHNICAL PARTICULARS FOR 36KV 1200A DB ISOLATORS

S.No	Item	Guaranteed value
	xii) Tandem pipe	:
	a) Size, class and No. of pipes	: 25mm NB Class B, as per GA drgs
	b) Size of shackle, screw	: Suitable for 25 NB pipe
	c) No. of bearings/bush and its material and size	: Not applicable
	xiii) Type of interlock	: Not applicable
	xiv) Down pipe size and class	: 40 NB Class B GI pipe
	xv) Type of universal/swivel joint	:
	a) Between bearing and down pipe	: Swivel Joint
	b) Between down pipe and operating mechanism	: Vernier flange
	xvi) Operating mechanism	: Manual operated mechanism for main switch
	a) Control cabinet material and thickness	: 3.mm THK Aluminum Sheet
	Degree of protection	: IP: 55 as per IS: 2147
	Type, size and No. of cable glands	: Double compression type 2Nos. 19 mm (Contractor scope of supply)
	Whether removable gland plate provided	: Yes, removable gland plate provided.
	b) Make, type, rating and quantity of motors	: Not applicable
	Auxiliary switch	: 4 NO + 4 NC Contacts for Isolator
	Terminal blocks	: 10 Amps, 2 A DC Breaking with 2A - 1 No.
	Insulated wires	: UBT-4
	xvii) Base:	: 1100 V grades, 2.5 Sq. mm PVC cable
	a) Size of steel section used	: 100x50x5mm channel (M.S.HDG)
	b) Overall sie	: 100 x 50 x 1050 mm
	c) Total weight.	: 9Kgs (Approx.) one pole
18	List of drawings furnished.	: Enclosed.
	Name of the firm	: For Pavani Power Systems Pvt. Ltd.
	Signature of Bidder	: 
	Designation & Seal	: (T. SESHAGIRI RAO) Managing Director
	Drawing approval subject to valid vendor registration	
	Date	: 18-05-2023

NOTE : DRAWING APPROVAL SUBJECT TO VALID TYPE TEST REPORTS, TO BE CHECKED DURING ACCEPTANCE TESTS.

FOR EPC CONTRACTS ONLY

Chief Engineer (Projects)

APTransco

7433670/2023/EEMRT-ENE51

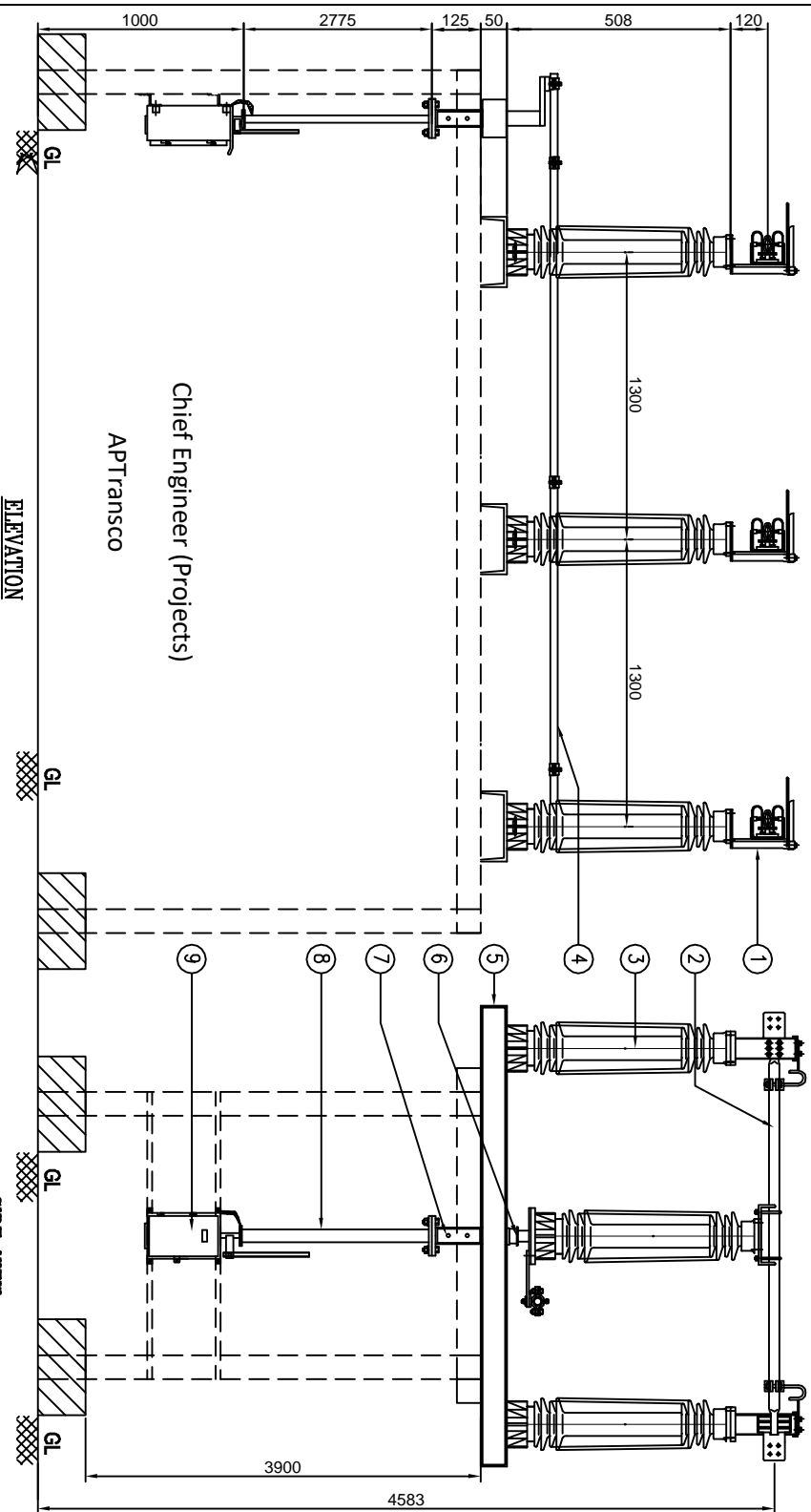

Chief Engineer (Projects)
APTransco

ELEVATION

SIDE VIEW

Drawing approval subject to valid vendor registration

For Pavani Power Systems Pvt. Ltd.

(T. SESHAGIRI RAO)
Managing Director

TRANSMISSION CORPORATION OF
ANDHRA PRADESH LTD



TRANSMISSION CORPORATION OF
ANDHRA PRADESH LTD

PART LIST

1. FIXED CONTACT ASSEMBLY
2. MOVING CONTACT ASSEMBLY
3. INSULATOR STACK (COSTUMER SCOPE)
4. TANDEM PIPE FOR ISOLATOR(25NB, CLASS"B" G.I PIPE)
5. BASE CHANNEL (100 X 50 X 5MM THK. M.S HDG)
6. ROTATING STOOL BASE WITH LEVER ARM & CLAMP (M.S HDG)
7. SWIVEL JOINT (M.S HDG)
8. DOWN PIPE FOR ISOLATOR (40NB CLASS"B" G.I PIPE)
9. MANUAL OPERATING MECHANISM FOR ISOLATOR

REFERENCE DRAWINGS:

1. FOR ISOLATOR CONTACT ASSEMBLY (1200 AMPS)
2. FOR MANUAL OPERATED MECHANISM FOR ISOLATOR
3. FOR NAME PLATE DETAILS

NOTE:

1. ALL DIMENSIONS ARE IN MILLIMETERS
2. THE INDICATED DIMENSIONS ARE SUBJECT TO THE MANUFACTURING TOLERANCE:
UP TO 50mm -----±3%; 51 TO 100mm ----- ±2%
101 TO 300mm -----± 1%; ABOVE 300mm -----±0.5%
3. SHORT TIME CURRENT RATING 31.5KA rms. FOR 3 Sec.
4. MIN. CREEPAGE DISTANCE 900 mm(25mm/KV)
5. APPLICABLE STANDARD : IEC: 62271-102
6. ALL FERROUS PARTS ARE HOT DIP GALVANIZED (85MICRONS)

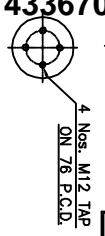

INSULATOR FIXING DETAILS
TOP / BOTTOM P.C.D. 76

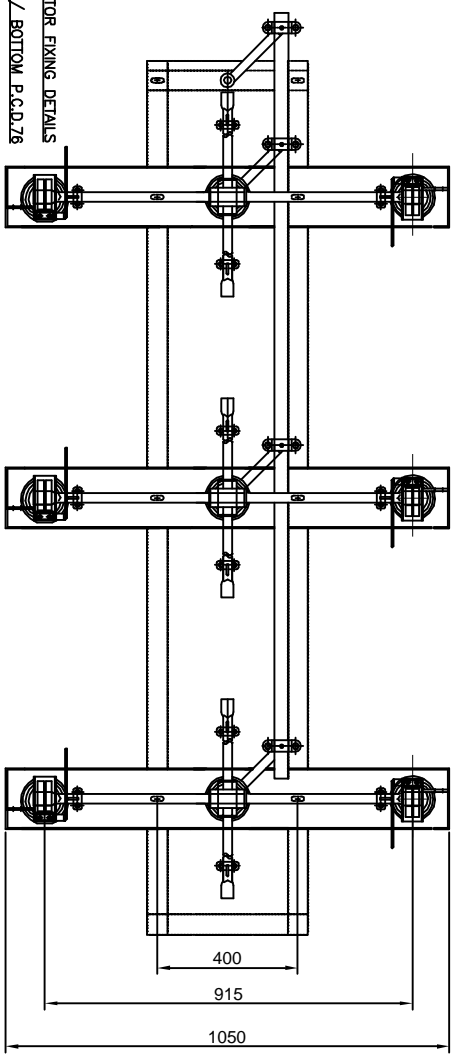

PLAN

REVISONS	D	C	B	A

TYPIE:

36KV 1200 A, TP, HDB, RT, ISOLATOR WITHOUT E.S.
(WITH MANUAL OPERATING MECHANISM)



PAVANI POWER SYSTEMS PVT.LTD.
Plot No. 05/055/4/6, K.K.OWNERS SOCIETY,
DHA, DULAPALLY, QUTHUBULLAPUR MANDAL,
KOMURU FORT, HYDERABAD - 500100.
KEROVAL MALKAJGIR DIST. TELANGANA

SCALE: 1:1	DATE	DRAWN	CHECKED	APPROVED	SHEET	DWG. No.
1:1	18-05-2023				01 OF 04	PPSP1-APT-CAD-44-01

FIXED CONTACT ASSEMBLY:
Drawing approval subject to valid vendor registration

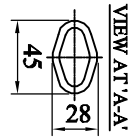
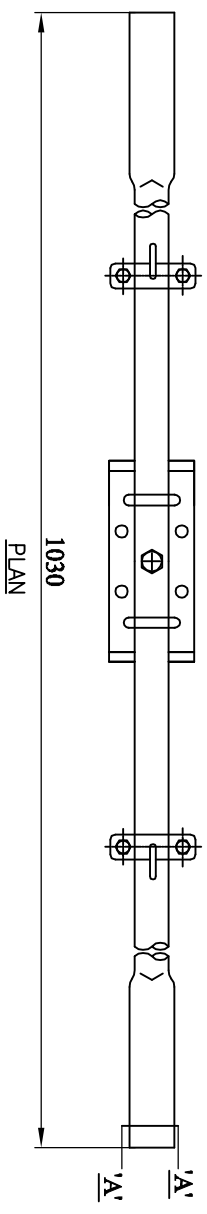
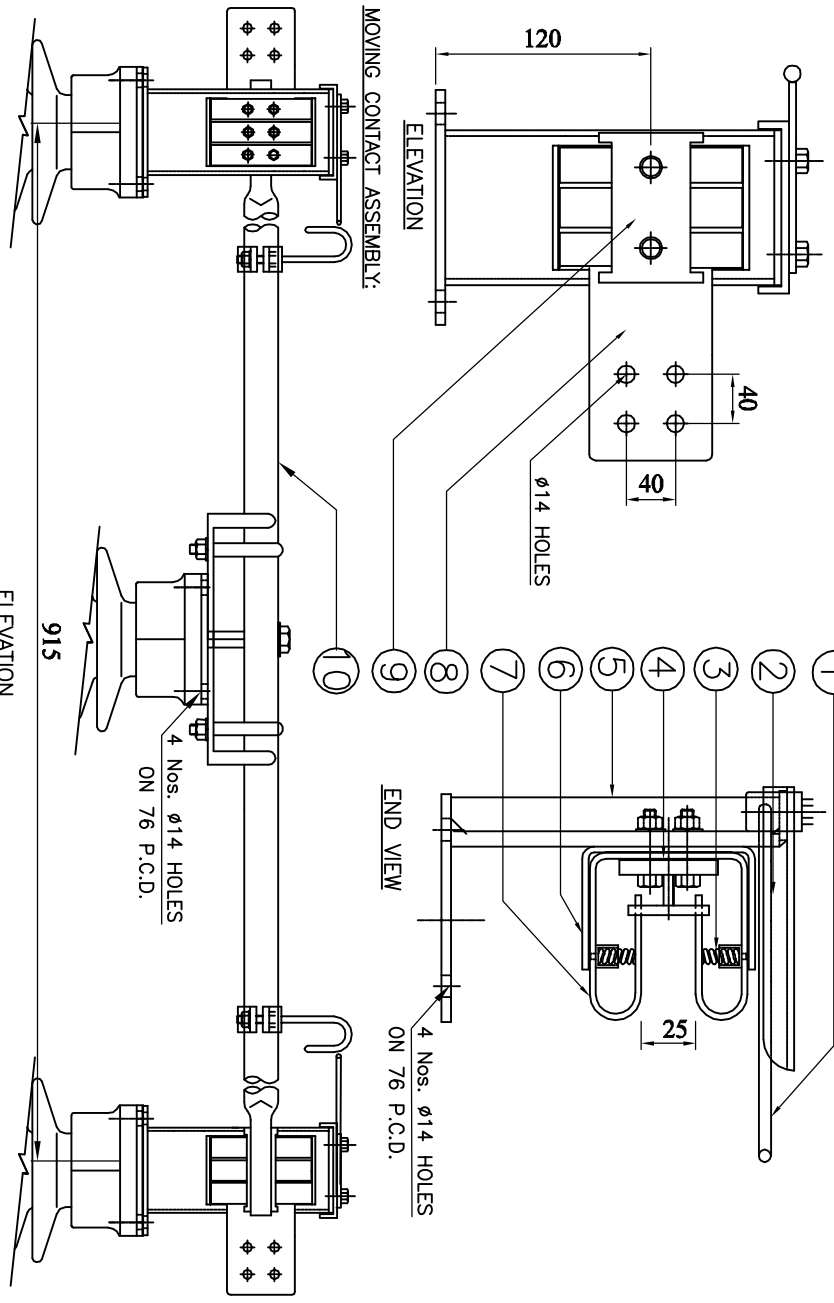

BILL OF MATERIAL PER ONE SET

SL NO.	DESCRIPTION	SIZE IN MM	MATERIAL
1.	ARCING HORNS	ø10MM ROD	M.S HDG
2.	RAIN HOOD	1.MM SHEET	M.S HDG
3.	JAW SPRINGS	ø2.mm WIRE	STAINLESS STEEL
4.	BI-METALLIC SHEET	2.mm THK	ALU. + CU.
5.	FIXED CONTACT SUPPORT CHANNEL	115 x 30 x 4 mm	M.S HDG
6.	JAW SUPPORT BRACKETS	32 X 5 FLAT	M.S HDG
7.	FIXED CONTACT JAWS (3. NOS)	32 X 4 FLAT	HDEC
8.	JUMPER PAD	100 X 12 FLAT	ALUMINIUM
9.	FC SPACER	-----	ALUMINIUM
10.	MOVING CONTACT	50-OD X 41-ID	HDEC

NOTE:

1. ALL DIMENSIONS ARE IN MILLIMETER
2. ALL FERROUS PARTS ARE HOT DIP GALVANIZED (85 MICRONS)
3. ALL NON FERROUS CONTACT POINTS ARE SILVER PLATED (15 MICRONS)
4. MOVING CONTACT ASSEMBLY SHOWN IS FOR TURN & TWIST ASSEMBLY

For Pavani Power Systems Pvt. Ltd.

(T. SESHAGIRI RAO)
Managing Director

TRANSMISSION CORPORATION OF
ANDHRA PRADESH LTD



Chief Engineer (Projects)
APTranSCO

REVISIONS		SCALE	
D	C	DATE	BY

TITLE: MAIN SWITCH CONTACT ASSEMBLY (FOR 36KV, 1200A ISOLATOR)		SCALE: 1:1
PAVANI POWER SYSTEMS PVT.LTD. Plot No. 05/055/4/6, K.K. OVERSEAS SOCIETY, TDA, DULLAPALLY, QUTHUBULLAPUR MANDAL, KODURU ROAD, HYDERABAD - 500100. MEDICAL MARKAGER DIST. TELANGANA		DATE: 18-05-2023 DRAWN:
AP TRANSCO		CHECKED:
APPROVED:		SHEET: 02 OF 04
Dwg.No: PPS/PT-MCA-44-02		

7433670/2023/FEMRT/FNE51

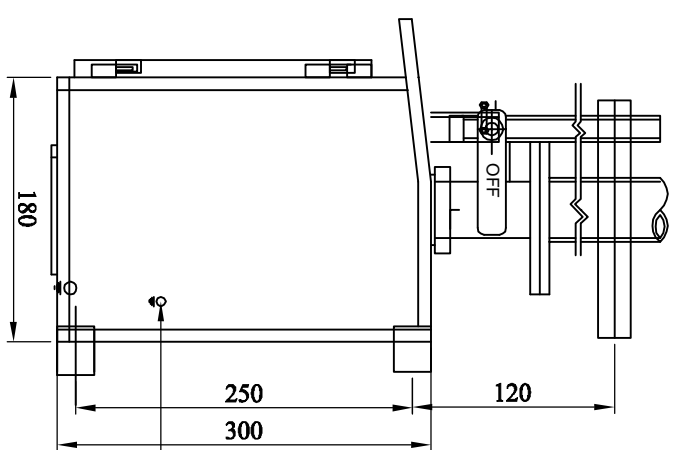

END VIEW

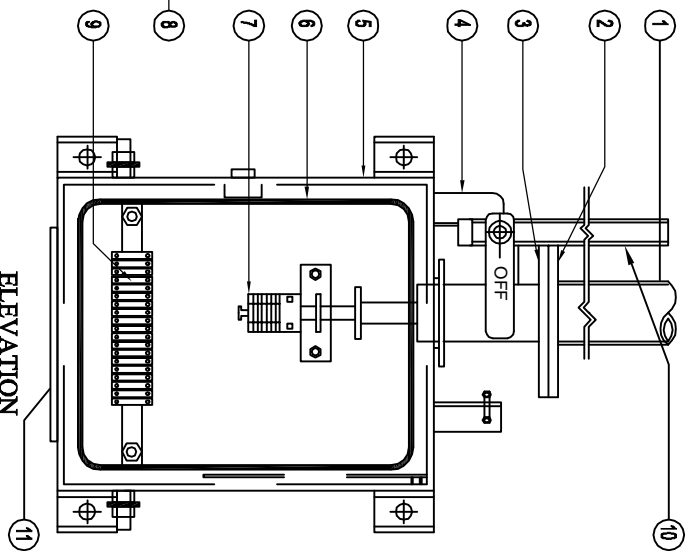

ELEVATION

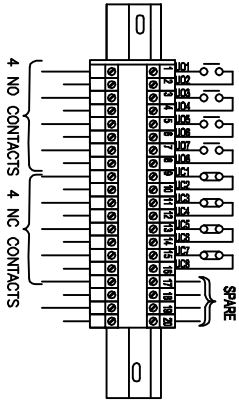

AUX. SWITCH CONTACT DETAILS FOR ISOLATOR (4NO + 4NC)

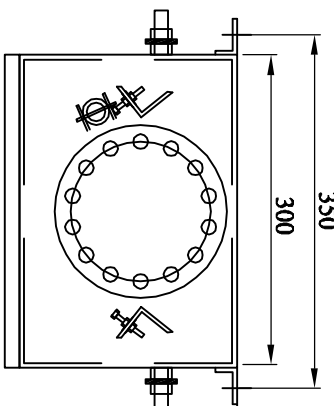

PLAN

Drawing approval subject to valid vendor registration

NOTES :

- ALL DIMENSIONS ARE IN MILLIMETERS
- CUBICLE WILL BE POWDER COATED WITH LIGHT GRAY SHADE NO:631 OF IS : 5
- DEGREE OF PROTECTION IP: 55 AS PER IS :13947
- 20% SPARE TERMINALS WILL BE PROVIDED AND SHALL BE UNIFORMLY DISTRIBUTED TO ALL TERMINAL BLOCKS EQUALLY
- WIRING WILL BE DONE WITH 1100V.GRADE 2.5 Sq.MM CU STRANDED P.V.C. INSULATED CONDUCTOR
- WEIGHT OF THE BOX : 20Kg (APPROX.)

PART LIST:-

1. DOWN PIPE
2. 12-HOLES FLANGE 8MM THK. (HDG)
3. 14-HOLES FLANGE 8MM THK. (HDG)
4. ON & OFF STOPPER
5. CUBICAL WITH DOOR 3mm Alu. SHEET
6. RUBBER GASKET (EPDM)
7. AUXILIARY SWITCH 4NO + 4NC
8. EARTHING TERMINAL-2 Nos.
9. TERMINAL BLOCK
10. OPERATING HANDLE
11. DETACHABLE TYPE CABLE GLANDS PLATE

FOR EPC CONTRACTS ONLY

Chief Engineer (Projects)

APTransco

(T. SESHAGIRI RAO)
Managing Director

For Pavani Power Systems Pvt. Ltd.



TRANSMISSION CORPORATION OF
ANDHRA PRADESH LTD

<p>TYPE: MANUAL OPERATING MECHANISM BOX (FOR 36KV ISOLATOR)</p>		<p>SCALE: 1:1</p>								
<p>REVISIONS</p> <table border="1"> <tr> <th>D</th> <th>C</th> <th>B</th> <th>A</th> </tr> <tr> <td> </td> <td> </td> <td> </td> <td> </td> </tr> </table>	D	C	B	A					<p>DATE: 18-05-2023</p>	<p>DRAWN: [Signature]</p>
D	C	B	A							
<p>PAYANI POWER SYSTEMS PVT.LTD. Plot No. 05/055/4/6, K.K. OPENERS SOCIETY, KODAPALI POST, HYDERABAD - 500100. NEERUCHAL NALKADUR DIST. TELANGANA</p>		<p>CHECKED: [Signature]</p>								
<p>AP TRANSSCO</p>		<p>APPROVED: 05 07 04</p>								
<p>DWG.No: PPSPl-APT-0M-44-03</p>		<p>DATE: 18-05-2023</p>								

Drawing approval subject to valid vendor registration



MANUFACTURED & SUPPLIED BY
PAVANI POWER SYSTEMS PVT.LTD.
 PLOT No.05/055/A/6, K.K.OWNERS SOCIETY, DULAPALLY INDUSTRIAL AREA,
 KOMMPALLY POST, HYDERABAD-500100, MEDCHAL MALKAJGIRI DIST. T.S.

ISOLATOR RATING NAME PLATE

CLIENT: TRANSMISSION CORPORATION OF A.P LTD

CUSTOMER: -----

PO No / DATE: -----

YEAR OF MFG. ----- **SL.No.** -----

TYPE DBR **FREQUENCY (Hz)** 50

VOLTAGE (kV) 36 **I.W. VOLTAGE** 170kVp

STC KA / SEC. 31.5/3 **P.F.W. VOLTAGE(DRY)** 70KV rms

CURRENT (A) 1200 **OPERATING DRIVE** MANUAL

CONTROL VOLTAGE 220 V DC

NOTE : DRAWING APPROVAL SUBJECT TO VALID TYPE TEST REPORTS, TO BE CHECKED DURING ACCEPTANCE TESTS.

1) Minimum 300mm plinth shall be maintained for CT/PT/CVT/Isolators in the substation during foundation works to ensure safe live to ground clearances as per IE rules.

2) Since the supply of terminal connectors is not in the scope of manufacturer as mentioned in the drawings, the EPC contractors shall be instructed to supply the same in line with CT/PT/CVT/Isolators requirement and compatibility.

Chief Engineer (Projects)

APTransco

(T. SESHAGIRI RAO)
 Managing Director

For Pavani Power Systems Pvt. Ltd.

TRANSMISSION CORPORATION OF
 ANDHRA PRADESH LTD



AP TRANSCO

REVISIONS
D C B A

NAME PLATE DETAILS
 (33kV ISOLATOR)



PAVANI POWER SYSTEMS PVT.LTD.
 Plot No. 05/055/A/6, K.K.OWNERS SOCIETY,
 DDA, DULAPALLY, QUTHBULLAPUR MANDAL,
 KOMMPALLY POST, HYDERABAD - 500100,
 MEDCHAL MALKAJGIRI DIST. TELANGANA

SCALE: 1:1	DATE: 18-05-2023
DRAWN	CHECKED
APPROVED	DATE: 04.07.04
DWG.No: PPS/Pl-APT-NPD-44-04	