

NOTE:- THIS COMPLETE SET OF DRAWINGS ARE REPRESENTATIVE OF THE LATEST TYPE TEST REPORT AND PROPRIETARY DESIGN, RESEARCH & DEVELOPMENT OF SWITCHGEAR MANUFACTURING COMPANY PVT. LTD. GANDRAJUPALLE. THE DESIGNS SHALL NOT BE REPRODUCED WITHOUT WRITTEN CONSENT OF SWITCHGEAR MANUFACTURING COMPANY PVT. LTD. GANDRAJUPALLE.

NOTE: 1. Drawings Approval subject to valid type test reports, to be checked during acceptance tests.  
2. For EPC contractors only.

REV	DATE	CHANGES MADE	SIG



1. Minimum 300mm plinth shall be maintained for CT/PT/CVT/Isolators/IV/LA/Breakers in the substation during foundation works to ensure safe live to ground clearance per IE rules.
2. Since the supply of terminal connectors is not in the scope of manufacturer as mentioned in the drawings. The EPC contractor shall be instructed to supply the same line with CT/PT/CVT/Isolator/IVT/LA/Breaker's requirement and compatibility.

### LIST OF DRAWINGS/DOCUMENTS FOR 33KV DBR DISCONNECTOR

S NO.	TITLE	DRAWING NO.	REV	SHEET
1	GA OF 33kv 1200A 'DBR' DISCONNECTOR WITHOUT EARTH SWITCH	STD-3300006	0	1 OF 1
2	DETAILS OF MAIN CONTACT (33KV 1200A DBR DISCONNECTOR)	STD-3300007	0	1 OF 1
3	GA OF MANUAL OPERATING MECHANISM FOR DISCONNECTOR	STD-3300008	0	1 OF 1
4	NAME PLATE DETAILS (FOR 33KV DBR DISCONNECTOR)	STD-3300009	0	1 OF 1

Drawing approval subject to valid vendor registration

**CHIEF ENGINEER/PROJECTS**  
**APTRANSCO/VISVIJAYAWADA**

DRN	YVG	04.06.22		SWITCHGEAR MANUFACTURING COMPANY	
CHKD	VK	04.06.22		GANDRAJUPALLE, CHITTOOR DIST, A.P, INDIA.	
APPD	OJA	04.06.22		TITLE	
DEPT	SIGN	DATE	MASTER LIST		
			<b>FOR 33KV DBR DISCONNECTOR</b>		
	SC: NTS	Paper size A3	DRG.NO. S T D - 3 3 0 0 0 0 5	SHEET 1 OF 1	REV. 0

NOTE:- THIS COMPLETE SET OF DRAWINGS ARE REPRESENTATIVE OF THE LATEST TYPE TEST REPORT AND PROPRIETARY DESIGN, RESEARCH & DEVELOPMENT OF SWITCHGEAR MANUFACTURING COMPANY PVT. LTD. GANDRAJUPALLE. THE DESIGNS SHALL NOT BE REPRODUCED WITHOUT WRITTEN CONSENT OF SWITCHGEAR MANUFACTURING COMPANY PVT. LTD. GANDRAJUPALLE.

NOTE: 1. Drawings Approval subject to valid type test reports, to be checked during acceptance tests.  
 2. For EPC contractors only.

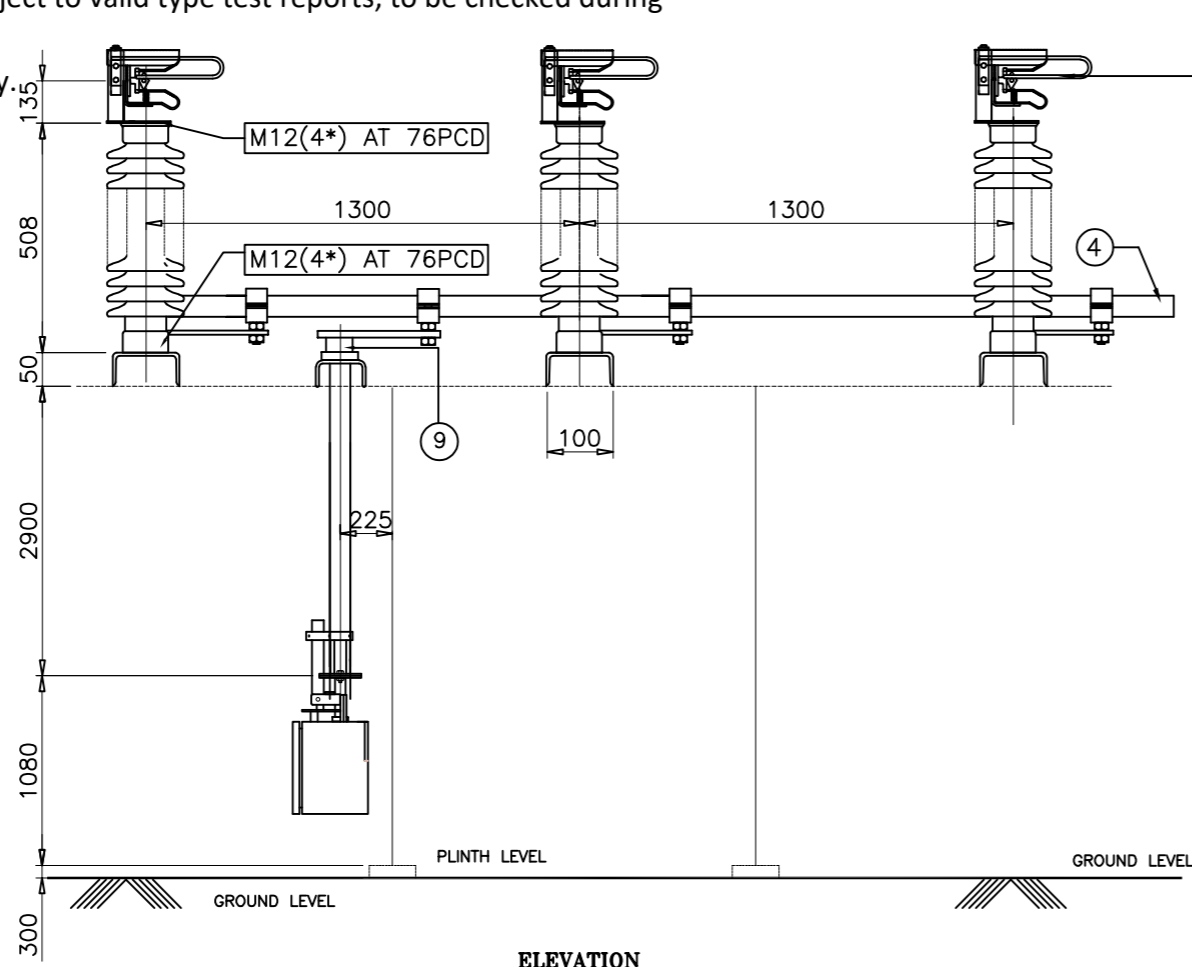

**ELEVATION**

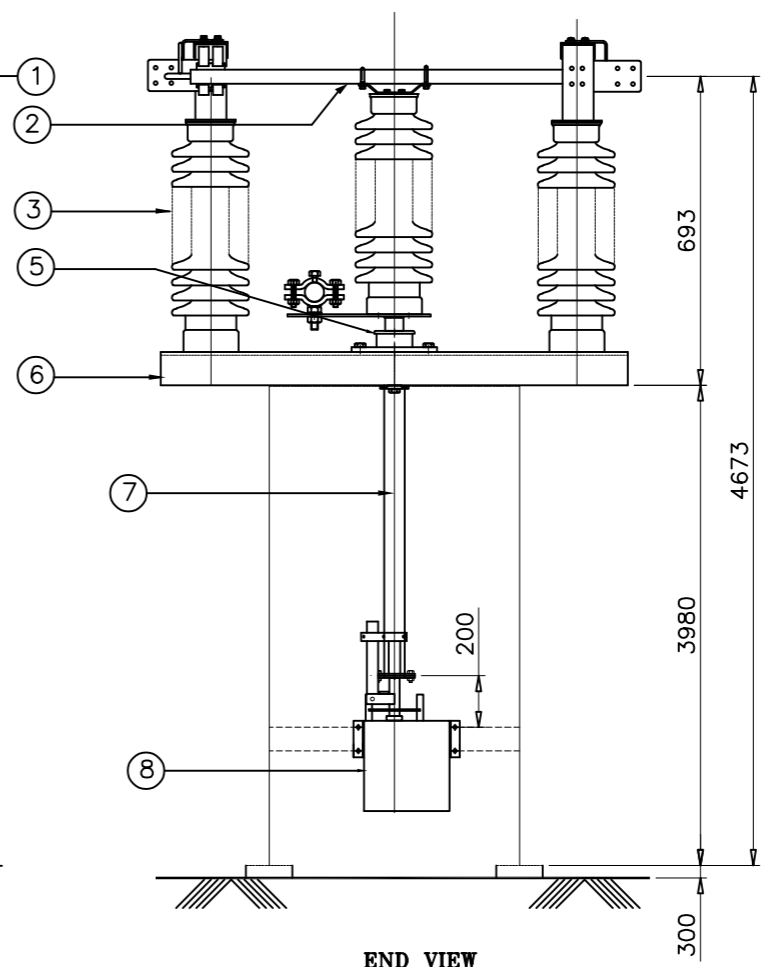

**END VIEW**

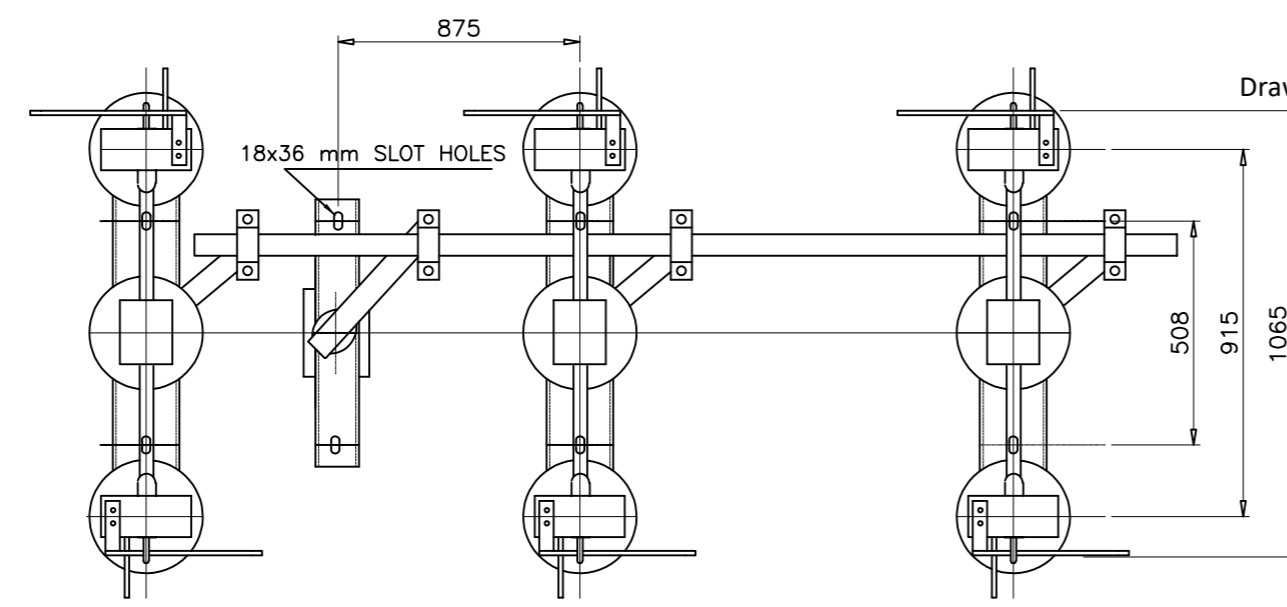

**PLAN**

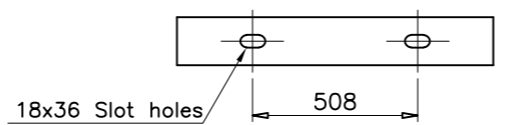

**BASE CHANNEL MOUNTING DETAILS**

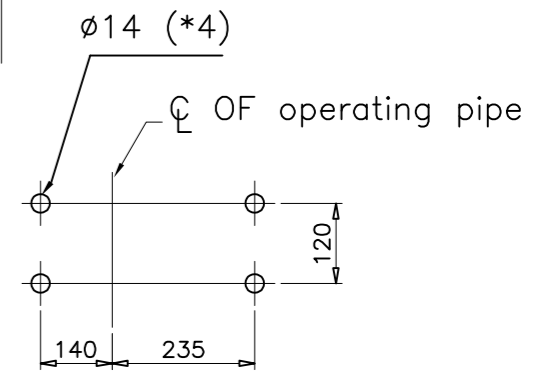

**FIXING DETAIL OF M/S BOM BOX**

**CHIEF ENGINEER/PROJECTS**  
**APTRANSCO/VISVIJAYAWADA**

PART LIST	QTY.
1 FIXED CONTACT ASSEMBLY	6
2 MOVING CONTACT ASSEMBLY	3
3 INSULATOR STACK	9
4 TANDEM PIPE (25 NB GI PIPE)	1
5 ROTATING STOOL POST	3
6 BASE CHANNEL (100X50X5MM THK)	3
7 OPERATING PIPE (40 NB GI PIPE)	1
8 OPERATING MECHANISM BOX (MANUAL)	1
9 TOP OPERATING MECHANISM	1

**NOTES**

- All Dimensions are in mm
- All Ferrous Parts are in Hot Dip Galvanized with 85 Microns.
- All non Ferrous Contact Points are Silver Plated with 15 Microns.
- The main Rotating Post has Two Nos of Bearings
- All GI Pipes are 'B' Class as per IS:1239
- Manufacturing Tolerance
  - Up to 50mm-- ±3%
  - 51 to 100mm-- ±2%
  - 101 to 300mm-- ±1%
  - Above 300mm-- ±0.5%
- Weight of Metallics - 220kgs (Approx.)

REV	DATE	CHANGES MADE	SIG

REF. STANDARD	IEC:62271-102 / IS:9921
WEIGHT (APPROX.)	KGS 410
CONTROL VOLTAGE DC	V 220
CROSS	kg -
TL STRAIGHT	kg -
ACROSS	kVp 80
PF TO EARTH	kVp 70
ACROSS	kVp 195
LI TO EARTH	kVp 170
STC PEAK	kAp 62.5
FOR 1 Sec	kA 25
CURRENT	A 1200
VOLTAGE	kV 33
DESCRIPTION	UNIT VALUE
<b>TECHNICAL DATA</b>	

Drawing approval subject to valid vendor registration

DRN	YVG	04.06.22	<b>SWITCHGEAR MANUFACTURING COMPANY</b> <b>GANDRAJUPALLE, CHITTOOR DIST, A.P, INDIA.</b>
CHKD	VK	04.06.22	
APPD	OJA	04.06.22	TITLE
DEPT	SIGN	DATE	<b>33KV 1200A DBR DISCONNECTOR WITHOUT EARTH SWITCH</b>
	SC: NTS	Paper size <b>A3</b>	DRG.NO. <b>S T D - 3 3 0 0 0 0 6</b>
			SHEET <b>1 OF 1</b>
			REV. <b>0</b>

NOTE:- THIS COMPLETE SET OF DRAWINGS ARE REPRESENTATIVE OF THE LATEST TYPE TEST REPORT AND PROPRIETARY DESIGN, RESEARCH & DEVELOPMENT OF SWITCHGEAR MANUFACTURING COMPANY PVT. LTD. GANDRAJUPALLE. THE DESIGNS SHALL NOT BE REPRODUCED WITHOUT WRITTEN CONSENT OF SWITCHGEAR MANUFACTURING COMPANY PVT. LTD. GANDRAJUPALLE.

**DETAILS OF FIXED CONTACT**

NOTE: 1. Drawings Approval subject to valid type test reports, to be checked during acceptance tests.  
 2. For EPC contractors only.

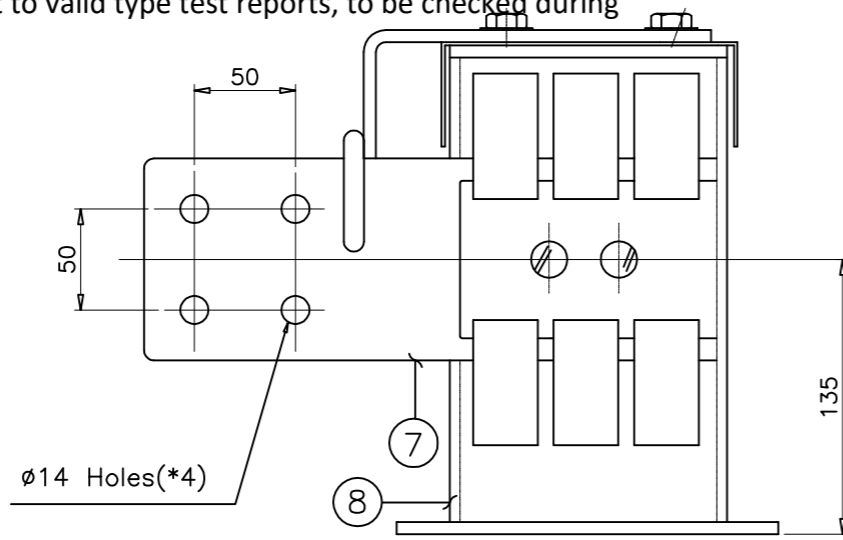

**ELEVATION**

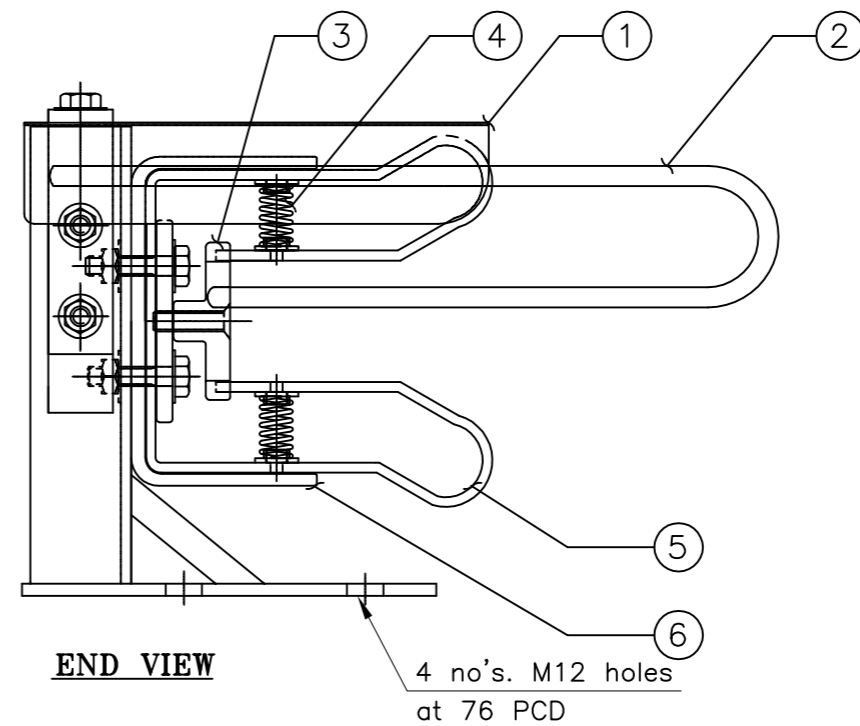

**END VIEW**

Drawing approval subject to valid vendor registration

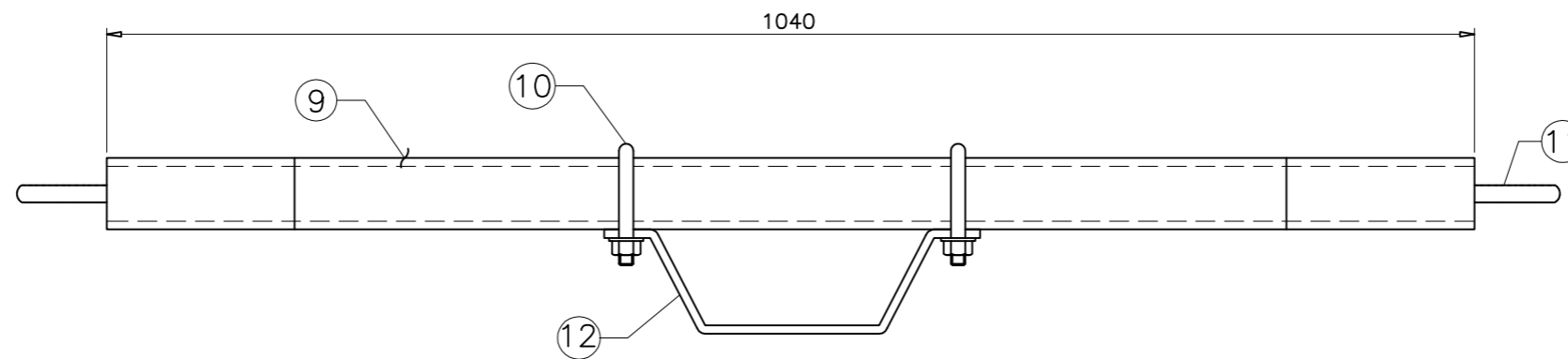

**ELEVATION**

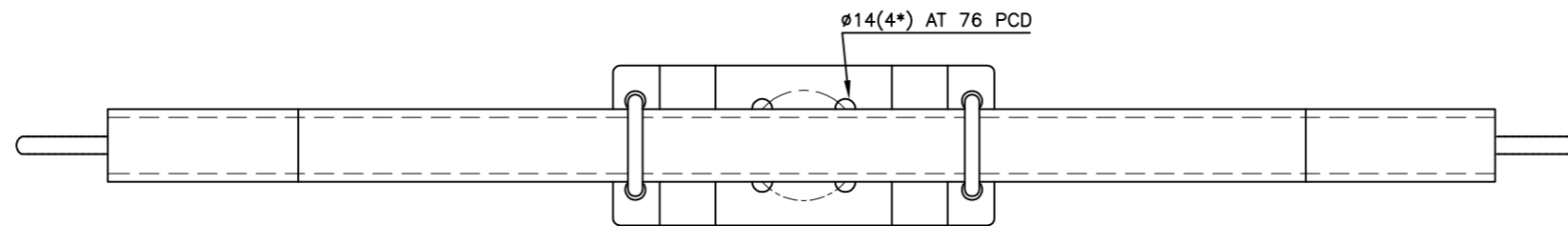

**PLAN**

1. Minimum 300mm plinth shall be maintained for CT/PT/CVT/Isolators/IV/LA/Breakers in the substation during foundation works to ensure safe live to ground clearance per IE rules.  
 2. Since the supply of terminal connectors is not in the scope of manufacturer as mentioned in the drawings. The EPC contractor shall be instructed to supply the same line with CT/PT/CVT/Isolator/IVT/LA/Breaker's requirement and compatibility.

**NOTES**

1. All dimensions are in 'mm'
2. All ferrous parts are hot-dip galvanized
3. All non-ferrous contact points are silver plated upto 15 microns
4. Tolerances
  - (i) Upto 50mm --- ±3%
  - (ii) 51 to 100 mm --- ±2%
  - (iii) 101 to 300mm --- ±1%
  - (iv) Above 300mm --- ±0.5%
5. Bolted area are Tin plated up to 10 microns to avoid bi-metallic reaction between Cu & Al

**PART LIST**

1. FC rain hood (AL.)
2. FC Arcing horn (MS HDG)
3. Spacer (AL.)
4. FC spring (SS)
5. FC Jaw (3Nos 32x4mm Cu.Flat)
6. Jaw back strip (MS HDG)
7. Jumper pad (100x12mm AL.)
8. Supporting channel (MS HDG)
9. MC arm ( 50 OD, 41 ID Cu.tube)
10. MC Clamp(MS HDG)
11. MC Arcing horn (MS HDG)
12. MC Holder (MS HDG)

Sl.No.	Cross section	Area	Current Rating	Current Density (Amps/sq.mm)	DRN	YVG	04.06.22	<b>SWITCHGEAR MANUFACTURING COMPANY</b> GANDRAJUPALLE, CHITTOOR DIST, A.P, INDIA.
1	(FC JAWS) 32X4X6	768mm <sup>2</sup>	1200A	1.56	CHKD	VK	04.06.22	
2	(MC ARM) 50 OD X 41 ID	642.91mm <sup>2</sup>	1200A	1.86	APPD	OJA	04.06.22	
2	JUMPER PAD (100X12)	1200mm <sup>2</sup>	1200A	1	DEPT	SIGN	DATE	

SC: NTS	Paper size <b>A3</b>	<b>DRG.NO. S T D - 3 3 0 0 0 0 7</b>	SHEET 1 OF 1	REV. 0
---------	-------------------------	--------------------------------------	-----------------	-----------

REV	DATE	CHANGES MADE	SIG

NOTE:- THIS COMPLETE SET OF DRAWINGS ARE REPRESENTATIVE OF THE LATEST TYPE TEST REPORT AND PROPRIETARY DESIGN, RESEARCH & DEVELOPMENT OF SWITCHGEAR MANUFACTURING COMPANY PVT. LTD. GANDRAJUPALLE. THE DESIGNS SHALL NOT BE REPRODUCED WITHOUT WRITTEN CONSENT OF SWITCHGEAR MANUFACTURING COMPANY PVT. LTD. GANDRAJUPALLE.

NOTE: 1. Drawings Approval subject to valid type test reports, to be checked during acceptance tests.  
 2. For EPC contractors only.

**PART LIST**

1. Down pipe
2. Flange (12Holes)
3. Flange (14Holes)
4. ON & OFF stopper
5. Locking block
6. Cubicle(3mm Al.Sheet)
7. Rubber liner for dust & weather proof
8. Cable gland fixing plate
9. Push button switch
10. Aux.switch (4NO + 4NC)
11. Terminal block (CTS4UN)
12. Earthing terminal
13. Provision for padlock (without lock)
14. Operating handle
15. Lock plate (For handle lock)
16. Plunger guide
17. Plunger
18. Solenoid
19. Fuses(5A)

**INSTRUCTIONS:**

- 1 Do not operate the main switch when breaker is at 'ON' position
- 2 To charge solenoid press push button. the solenoid is charged i.e mechanism is free to operate.
- 3 Do not padlock main switch unless interlocking plunger does not fall into provided slot.
- 4 Release push button to discharge solenoid.

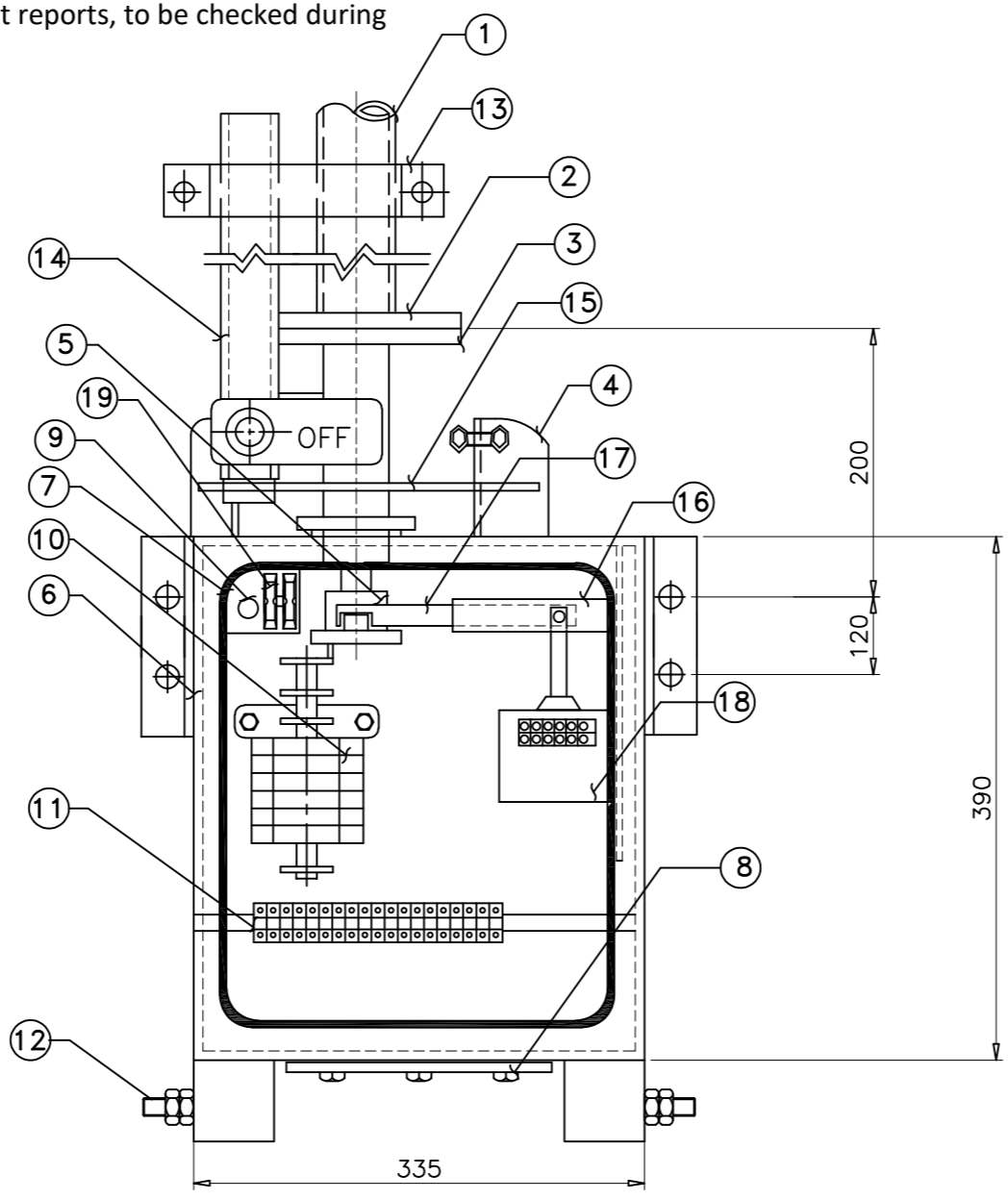

**ELEVATION**

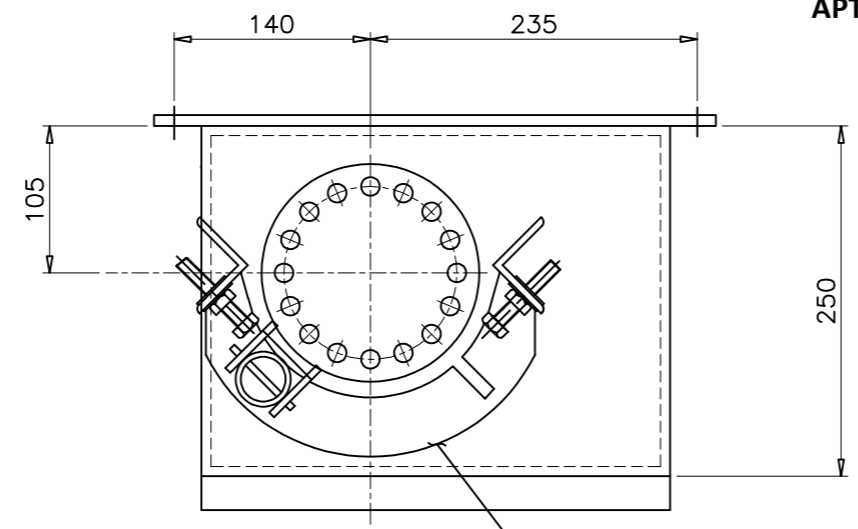

**PLAN**

**CHIEF ENGINEER/PROJECTS**  
**APTRANSCO/VS/VIJAYAWADA**

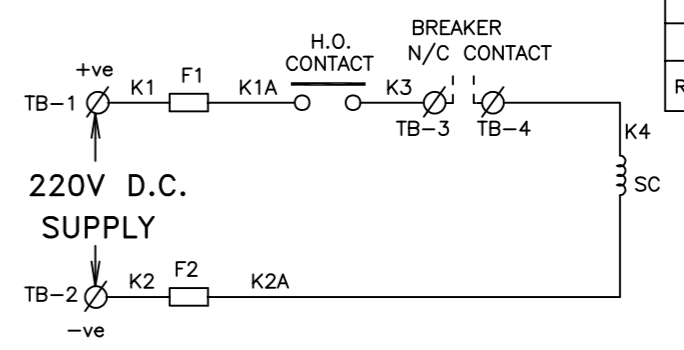

**SCHEMATIC DIAGRAM**

**LEGEND**

- F1,F2 --- Fuses for control supply  
 H.O.contact --- Hand operated control  
 S.C. --- Solenoid coil

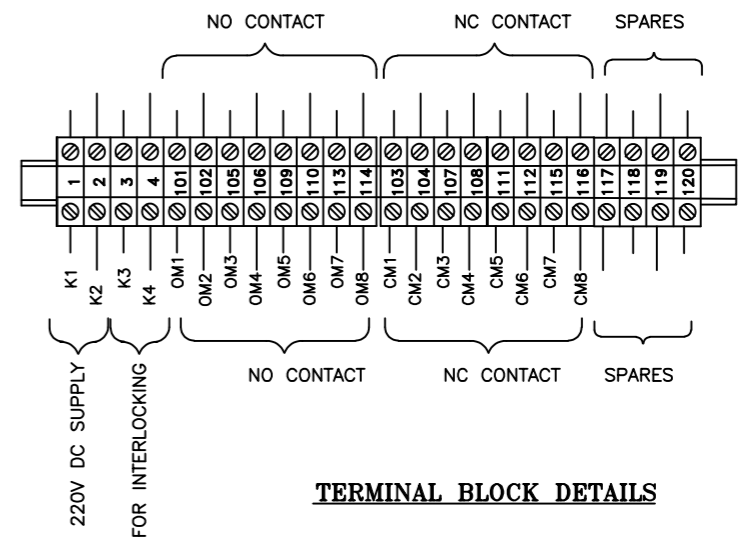

**TERMINAL BLOCK DETAILS**

Drawing approval subject to valid vendor registration

**NOTES:-**

- 1 All dimensions are in 'mm'
- 2 Cubicle will be painted to shade no. 631 of IS:5
- 3 Internal wiring will be done with 2.5 sq.mm cu.stranded conductor & 10% spare terminals will be provided
- 4 All ferrous parts are hot dip galvanised
- 5 Net weight of the box-28 Kgs(approx)

DRN	YVG	04.06.22	<b>SWITCHGEAR MANUFACTURING COMPANY</b> GANDRAJUPALLE, CHITTOOR DIST, A.P, INDIA.
CHKD	VK	04.06.22	
APPD	OJA	04.06.22	
DEPT	SIGN	DATE	TITLE
	SC: NTS	Paper size A3	<b>GENERAL ARRANGEMENT OF</b> <b>MANUAL OPERATING MECHANISM FOR DISCONNECTOR</b>
DRG.NO. S T D - 3 3 0 0 0 0 8			SHEET 1 OF 1 REV. 0

NOTE:- THIS COMPLETE SET OF DRAWINGS ARE REPRESENTATIVE OF THE LATEST TYPE TEST REPORT AND PROPRIETARY DESIGN, RESEARCH & DEVELOPMENT OF SWITCHGEAR MANUFACTURING COMPANY PVT. LTD. GANDRAJUPALLE. THE DESIGNS SHALL NOT BE REPRODUCED WITHOUT WRITTEN CONSENT OF SWITCHGEAR MANUFACTURING COMPANY PVT. LTD. GANDRAJUPALLE.

NOTE: 1. Drawings Approval subject to valid type test reports, to be checked during acceptance tests.  
2. For EPC contractors only.

1. Minimum 300mm plinth shall be maintained for CT/PT/CVT/Isolators/IV/LA/Breakers in the substation during foundation works to ensure safe live to ground clearance per IE rules.
2. Since the supply of terminal connectors is not in the scope of manufacturer as mentioned in the drawings. The EPC contractor shall be instructed to supply the same line with CT/PT/CVT/Isolator/IVT/LA/Breaker's requirement and compatibility.

REV	DATE	CHANGES MADE	SIG

## SWITCHGEAR MANUFACTURING COMPANY

GANDRAJUPALLE, CHITTOR DIST, A.P., INDIA.

CUSTOMER TRANSMISSION CORPORATION OF ANDHRA PRADESH LIMITED

SL.No.	(*)	TYPE	DBR
VOLTAGE (kV)	33	CURRENT (Amps)	1200
STC (kA-sec-kAp)	25-1-62.5	IMPULSE (kVp)	170
DC VOLTAGE (V)	220	PF VOLTAGE (kV)	70
DRIVE	MANUAL	FREQUENCY (Hz)	50
YEAR	(*)		

FOR DISCONNECTOR

(\*\*) TO BE MARKED AT THE TIME OF MANUFACTURING

**CHIEF ENGINEER/PROJECTS  
APTRANSCO/VS/VIJAYAWADA**

Drawing approval subject to valid vendor registration

**NOTE:**

1. ALL DIMENSIONS ARE IN MM
2. MATERIAL : ALUMINIUM ALLOY
3. TOLERANCE AS PER GA DRAWING
4. LETTER ITCHED ON BLACK BACKGROUND

DRN	YVG	04.06.22	<b>SWITCHGEAR MANUFACTURING COMPANY</b>
CHKD	VK	04.06.22	
APPD	OJA	04.06.22	<b>TITLE</b> NAME PLATE DETAILS
DEPT	SIGN	DATE	(FOR 33kV DBR DISCONNECTOR)
	SC: NTS	Paper size A3	DRG.NO. S T D - 3 3 0 0 0 0 9
			SHEET 1 of 1
			REV. 0

NOTE: 1. Drawings Approval subject to valid type test reports, to be checked during acceptance tests.

2. For EPC contractors only.  
**SWITCHGEAR MANUFACTURING COMPANY PRIVATE LIMITED**

CLIENT	:	TRANSMISSION CORPORATION OF ANDHRA PRADESH LIMITED
--------	---	--

**GUARANTEED TECHNICAL PARTICULARS FOR 33kV DBR DISCONNECTOR**

Sl. No.	Description	Particulars
1.	Type / Installation	Horizontal Double Break, Outdoor
2.	Manufacturer's name and place of Manufacture	<b>Switchgear Manufacturing Company Pvt. Ltd.</b> Gandrajupalle, Chittoor Dist, A.P, India.
3.	Standards according to which the isolators are manufactured	IS: 9921 (Part I to V) / IEC: 62271-102
4.	Maximum design voltage at which the isolator can operate (kV)	36
5.	Frequency (Hz)	50
6.	Rated Voltage (kV)	33
7.	Maximum current that can be safely Interrupted By the isolator	Inductive – 0.7 A at – 0.15 p. f. (Assigned value) Capacitive – 0.7 A at – 0.15 p. f. (Assigned value)
8.	Continuous current rating Nominal (Amps) under site conditions (Amps)	1200 Amps As required
9.	Rated short time current	
	i) for 1 second (kA rms)	25
	ii) Rated peak short time current (kAp)	62.5
10.	Current density at the minimum cross Section of	
	a) Moving blade (Amps/sq. mm) : Copper tube	2.0
	b) Terminal pad (Amps/sq. mm) : Aluminum	1.0
	c) Contacts (Amps/sq. mm) : Copper Flat	1.6
	d) Terminal connector (Amps/sq. mm): Aluminum Alloy	1.0
11.	Maximum Temp. rise of current carrying parts when carrying rated current continuously (deg.C)	Within the Limits as per Table 4 of IS : 9921 (Part-II) of 1982 / Table 3 of IEC 62271-1
12.	Derating factor for specified site conditions	Unity
13.	Insulation levels	
	i) Impulse withstand voltage (kV peak)	
	a) Phase to Earth	170
	b) Isolating Distance	195
	ii) Switching surge withstand voltage (kV peak)	
	a) Phase to Earth	Not Applicable
	b) Isolating Distance	Not Applicable
	iii) Power Frequency withstand voltage (kV rms)	
	a) Phase to Earth	80
	b) Isolating Distance	80
14.	Minimum clearance in air	
	i) Between poles (mm)	Phase spacing being 1300 mm
	ii) Between live parts and earth (mm)	Equal to the height of Insulators selected
	iii) Between live parts when switch is open	
	a) One the same pole (mm)	For center-to-center distance of 915 mm
	b) Between adjacent poles (mm)	1300 mm
15.	Rated mechanical terminal load	
	i) Load along the terminal connector side (Kg.)	Values not specified in Table 7 of IS: 9921 (Part II) of 1982
	ii) Load across the terminal connector side (Kg.)	
16.	Torque required to operate the switch in Kg-m	36
17.	Contact zone	Not Applicable
18.	Design and construction	
	i) No. of insulators per pole	3
	ii) No. of breaks per pole	2
	iii) Type of closing/opening mechanism (Horizontal/vertical) break straight etc.	Horizontal
	iv) Contacts	
	a) Material and grade	Hard drawn Electrolytic copper, Contact surface is silver plated
	b) Cross-sectional area (Sq. mm)	768 for 1200 Amps
	v) Moving blades	
	a) Material and grade	Hard drawn Electrolytic copper, Ends are silver plated
	b) Cross-sectional area(mm)	642.91 for 1200 Amps
	vi) Contact support	
	a) Type of contacts	Banging type

**CHIEF ENGINEER/PROJECTS  
APTRANSCO/VS/VIJAYAWADA**

Drawing approval subject to valid vendor registration

NOTE: 1. Drawings Approval subject to valid type test reports, to be checked during acceptance tests.

2. For EPC contractors only.  
**SWITCHGEAR MANUFACTURING COMPANY PRIVATE LIMITED**

CLIENT	:	TRANSMISSION CORPORATION OF ANDHRA PRADESH LIMITED
--------	---	--

	a)	Material and size of plate	M.S. plate, 6 mm HDG.
vii)		Rain hood-material grade and size	Aluminum sheet, 1mm THK
viii)			
	a)	Material and size of clamps	NA
	b)	Material size of springs	NA
	b)	Whether springs are encased	NA
ix)		Nuts and Bolts	
	a)	Size, Material and grade in live parts	Less than 5/8" dia. Stainless steel
	b)	Size, Material and grade in other parts	3/8" dia & above hot dip galvanised
x)		Insulator base plate Material and size of Plate below insulators	100X50X5MM THK M.S. Channel (HDG)
xi)		Bearings	
	a)	Material and size of housing	Gravity die cast Aluminium/MS Fabricated (HDG)
	b)	No. of bearings, location and Size	2 Nos. – below the rotating post Insulator with 32 mm shaft dia.
xii)		Tandem pipe	
	a)	Size, class and No. of pipes	1 No. – 25 NB, class B. G.I. pipes. of length as per GA.
	b)	Size of shackle, screw	16 mm dia
	c)	No. of bearings / bush and its material and size	Brass Bush – 2 Nos. suitable for 16 mm dia Stud.
xiii)		Type of interlock	Electrical between Main Switch & Corresponding circuit breaker
xiv)		Down pipe size and class	40 NB. Class B G.I. pipe
xv)		Type of universal/swivel joint	
	a)	Between bearings and down pipe	Flange type
	b)	Between down pipe and operating mechanism	Vernier type flange
xvi)		Operating Mechanism	3mm Aluminium
xvii)		Base	
	a)	Size of steel sections used	100 mm x 50 mm
	b)	Overall size	100 mm x 50 mm x 1065 mm
	c)	Total weight	10 Kg (one pole) approx.

For Switchgear Manufacturing Co. Pvt. Ltd.



Authorized Signatory

Drawing approval subject to valid vendor registration

1. Minimum 300mm plinth shall be maintained for CT/PT/CVT/Isolators/IV/LA/Breakers in the substation during foundation works to ensure safe live to ground clearance per IE rules.
2. Since the supply of terminal connectors is not in the scope of manufacturer as mentioned in the drawings. The EPC contractor shall be instructed to supply the same line with CT/PT/CVT/Isolator/IVT/LA/Breaker's requirement and compatibility.

**CHIEF ENGINEER/PROJECTS**  
**APTRANSCO/VS/VIJAYAWADA**