

This drawing is the property of TRITECH DISCONNECTORS (INDIA) PVT. LTD. and must not be passed on to any person or body not authorised by us to receive it nor be copied or otherwise made use either in full or in part by such person or body without our prior permission in writing.

NOTE:-1. Drawings approval subject to valid type test reports, to be checked during acceptance tests.
2. For EPC contractors only.

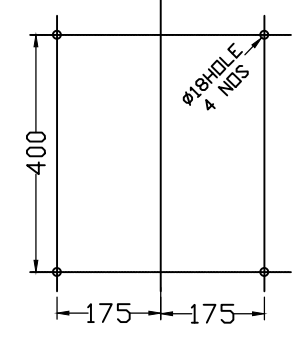
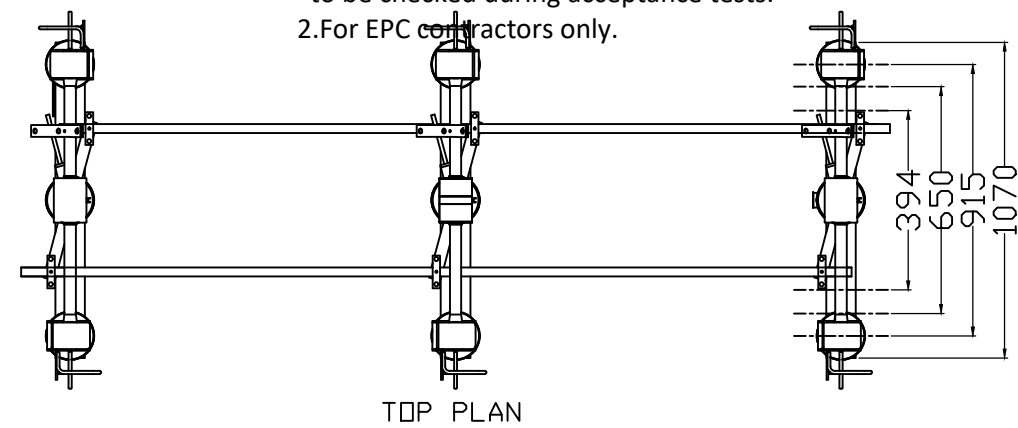

SR.	DESCRIPTION	MATERIAL	QTY/ISO
1	FIX CONTACT L-BRACKET	M.S. H.D.G.	6 NOS
2	FIX CONTACT	CU. FLAT	6 NOS
3	TANDEM CLAMP (MAIN SWITCH)	M.S. H.D.G.	6 NOS
4	TANDEM PIPE FOR MAIN, NB-25 CLS-B	G.I. PIPE	2 NOS
5	33KV INSULATOR (NOT IN TRITECH SCOPE)	PORCELAIN	9 NOS
6	DOWN OP. PIPE MAINS NB-40 CLS-B	G.I. PIPE	1 NO
7	OPERATING BOX FOR MAINS	AL	1 NO
8	MOVING CONTACT SUPPORT	M.S. H.D.G.	3 NOS
9	MOVING CONTACT	CU. PIPE	3 NOS
10	ROTATING BEARING HOUSING	AL.	3 NOS
11	BASE CHANNEL 100X50X5MM	M.S. H.D.G.	3 NOS
12	TERMINAL PAD	AL	6 NOS

NOTES:

- ALL DIMENSIONS ARE IN MM
- ALL FERROUS PARTS ARE IN HOT DIP GALVANISED.(87 MICRONS)
- ALL NON FERROUS CONTACT POINTS ARE SILVER PLATED. (15 MICRONS)
- THE MAIN ROTATING POST HAS TWO NOS. OF BEARING.
- ALL GI PIPES ARE 'B' CLASS AS PER IS:1239.
- MOUNTING STRUCTURE & MOUNTING FASTNERS ARE IN THE SCOPE OF CONTRACTOR, NOT IN TRITECH SCOPE.
- MANUFACTURING TOLERANCES:
I) UP TO 50MM - ±3% II) 51MM TO 100MM - ±2%
III) 101MM TO 300MM - ±1% IV) ABOVE 300MM - ±0.5%

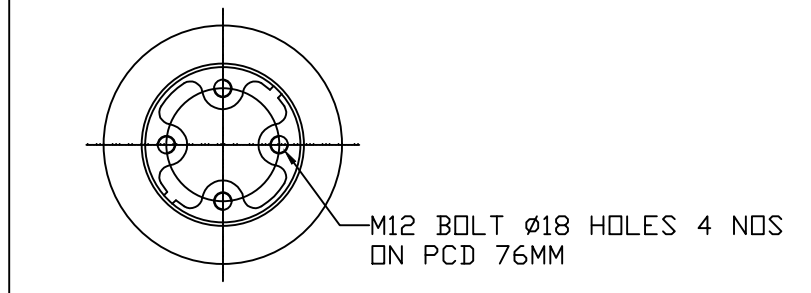
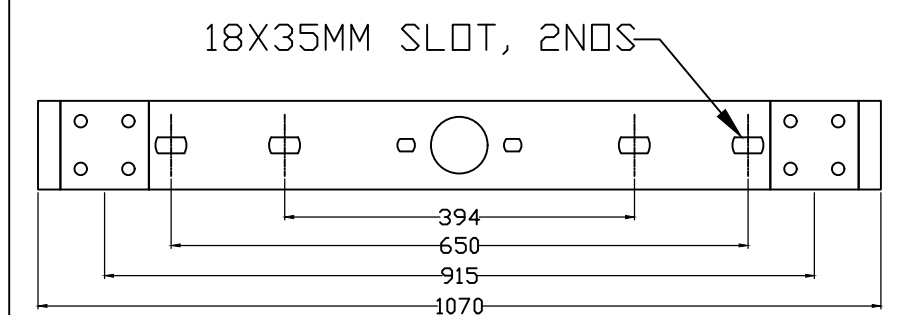
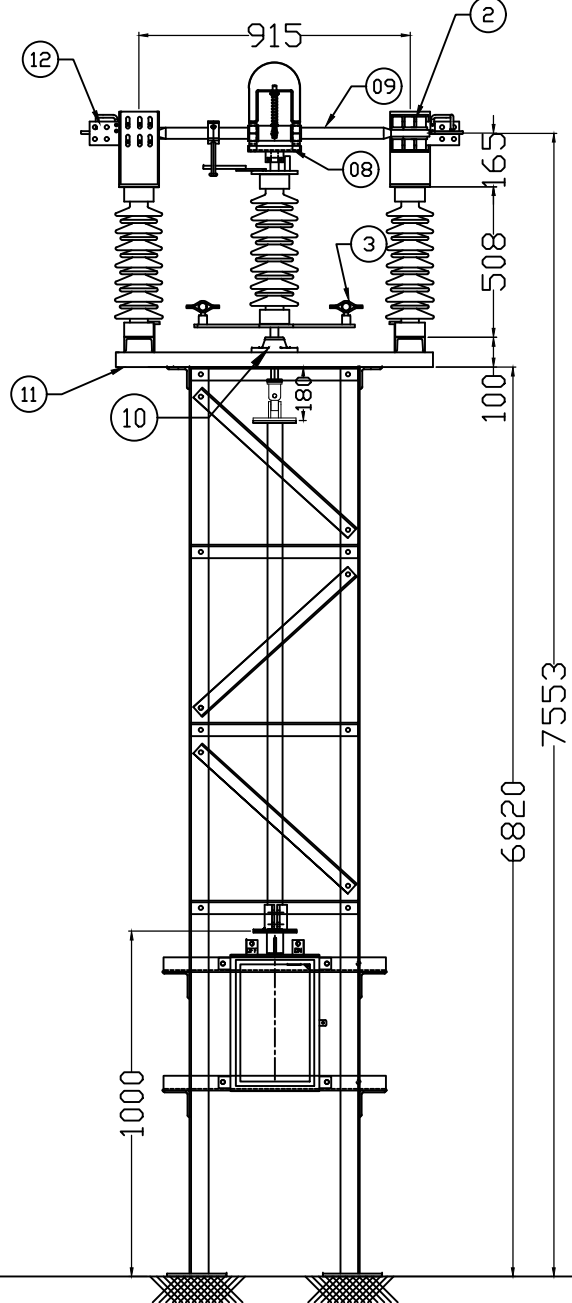
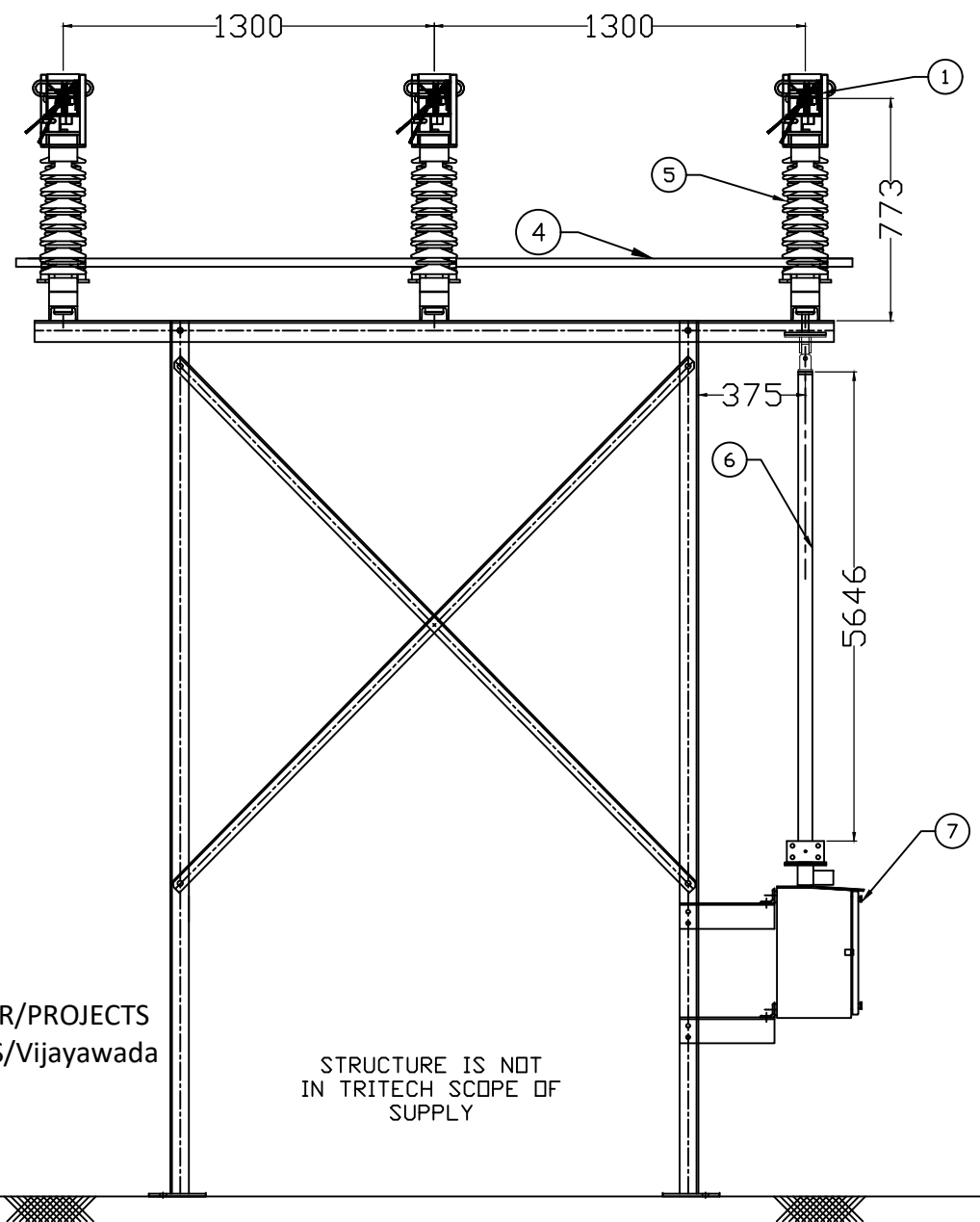

CHIEF ENGINEER/PROJECTS
APTRANSCO/VS/Vijayawada

STRUCTURE IS NOT IN TRITECH SCOPE OF SUPPLY

Drawing approval subject to valid vendor registration

TRITECH DISCONNECTORS (INDIA) PVT. LTD.
DISCONNECTORS (INDIA) PVT.LTD
MANUFACTURER OF HV/ EHV ISOLATORS

NAME	SIGN	DATE	TITLE
DRWN SHARAD	SRD	06.04.23	G.A. DRAWING OF 33kV 2000AMP ISOLATOR WITHOUT EARTH SW BUS SECTIONLISER SIDE: 7553MM
CHKD P JADHAV	P.J	06.04.23	
APPD P JADHAV	P.J	06.04.23	

REV NO	DATE	DESCRIPTION	SIGN
REVISION			

DWG. NO : I3204001APA	REV. NO. 00	SIZE A4	SHEET 1/1	SCALE 1:1	
-----------------------	-------------	---------	-----------	-----------	--

This drawing is the property of TRITECH DISCONNECTORS (INDIA) PVT. LTD. and must not be passed on to any person or body not authorised by us to receive it nor be copied or otherwise made use either in full or in part by such person or body without our prior permission in writing.

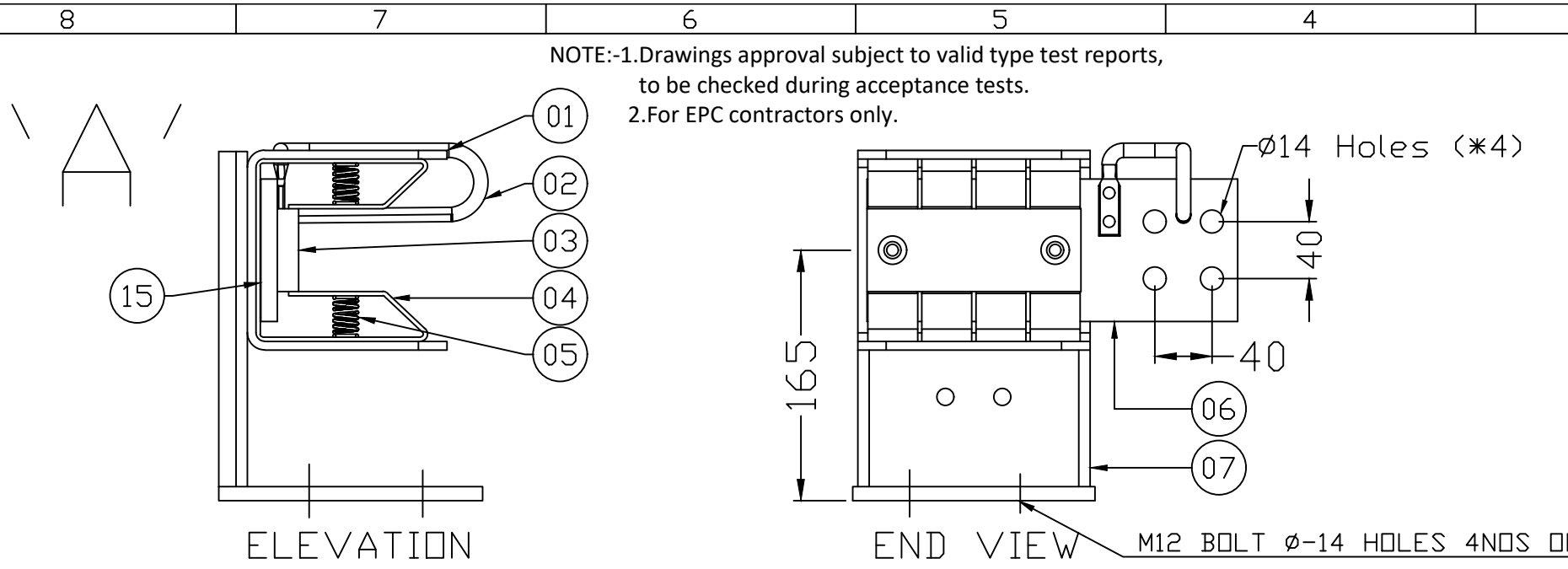

SR.	PART LIST	MATERIAL	QTY/ISO
1	FC C BRACKET / RAINHOOD-6MM THK	MS HDG	6 NOS
2	FC ARCING HORN-Ø10MM	MS HDG	6 NOS
3	SPACER-10MM THK	BACKELITE	3 NOS
4	FC M CONTACT (32X5)	CU	24 NOS
5	FC SPRINGS	SS	48 NOS
6	TERMINAL PAD (100X20)	AL	6 NOS
7	SUPPORTING CHANNEL-4MM THK	MS HDG	6 NOS
8	MC CANOPY (0.5MM THK.)	AL	6 NOS
9	MC SUPPORTING BLOCK	AL	6 NOS
10	MC COPPER TUBE HDEC(ØD-50 ID-34)	CU	3 NOS
11	MC ARCING HORN Ø10MM	MS HDG	6 NOS
12	CLAMP FOR TURN & TWIST-5MM THK	MS HDG	3 NOS
13	MC BASE PLATE FOR TURN & TWIST	MS HDG	3 NOS
14	MC SPRING (SS)	SS	3NOS
15	BI-METALLIC SHEET 2MM THK	AL+CU	6NOS

DETAILS OF FIXED CONTACT

- NOTE:
- ALL DIMENSIONS ARE IN MM.
 - ALL FERROUS PARTS ARE HOT DIP GALVANIZED.(87 MICRONS)
 - ALL HDE COPPER CONTACT POINTS ARE SILVER PLATED.(15 MICRONS)
 - TOLERANCE AS PER G.A. DRAWING.
 - FOR CONTACT DETAILS FIX CONTACT 'A' & MOVING CONTACT 'B' DETAILS REFER TABLE ANNEXURE 1
 - MOVING CONTACT LENGTH AND FIX CONTACT WILL VARY AS PER FIX CONTACT PAIRS REQUIRED AS PER ANNEXURE 1.

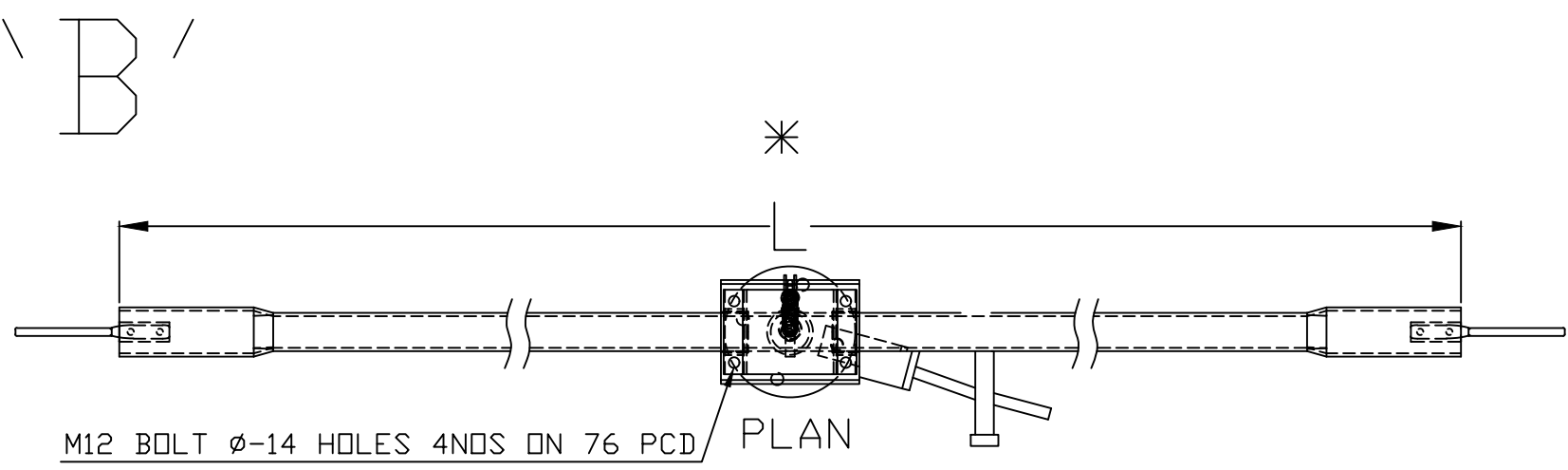

ANNEXURE 1

CURRENT RATING	FIXED CONTACT (A) (CU)				MOVING CONTACT (B) (CU)				TERMINAL PAD	
	SIZE MMxMM	PAIRS NO	AREA SQMM	CURRENT DENSITY A/SQMM	OD MM	ID MM	* (L) LENGTH MM	AREA SQMM	CURRENT DENSITY A/SQMM	SIZE MMxMM
2000	32X5.0	4	1280	1.6000	50	34	1084	1056	2.0000	100X20 AL.

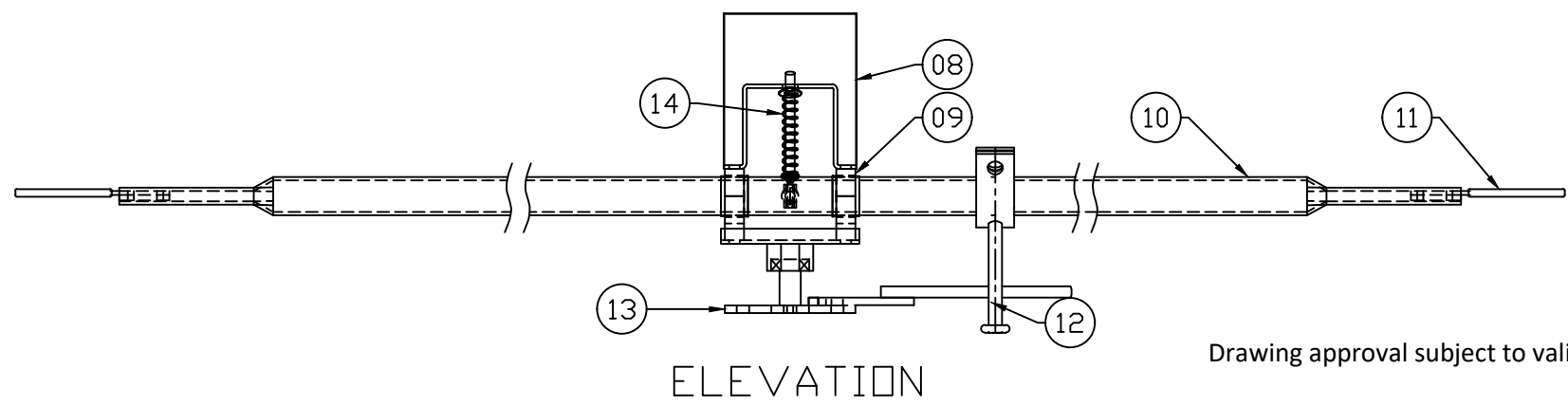

DETAILS OF MOVING CONTACT

CHIEF ENGINEER/PROJECTS
APTRANSCO/VS/Vijayawada

Drawing approval subject to valid vendor registration

TRITECH DISCONNECTORS (INDIA) PVT. LTD.
DISCONNECTORS (INDIA) PVT.LTD
MANUFACTURER OF HV/ EHV ISOLATORS

REV NO	DATE	DESCRIPTION	SIGN	NAME	SIGN	DATE	TITLE
				DRWN	SHARAD	SRD	06.04.23
				CHKD	P JADHAV	P.J	06.04.23
				APPD	P JADHAV	P.J	06.04.23

MAIN CONTACTS DETAILS FOR 33KV 2000AMP. ISOLATOR

REV. NO.	SIZE	SHEET	SCALE	
00	A4	1/1	1:1	

DWG. NO : A320MC00AP

This drawing is the property of TRITECH DISCONNECTORS (INDIA) PVT. LTD. and must not be passed on to any person or body not authorised by us to receive it nor be copied or otherwise made use either in full or in part by such person or body without our prior permission in writing.

NOTE:-1. Drawings approval subject to valid type test reports, to be checked during acceptance tests.
2. For EPC contractors only.

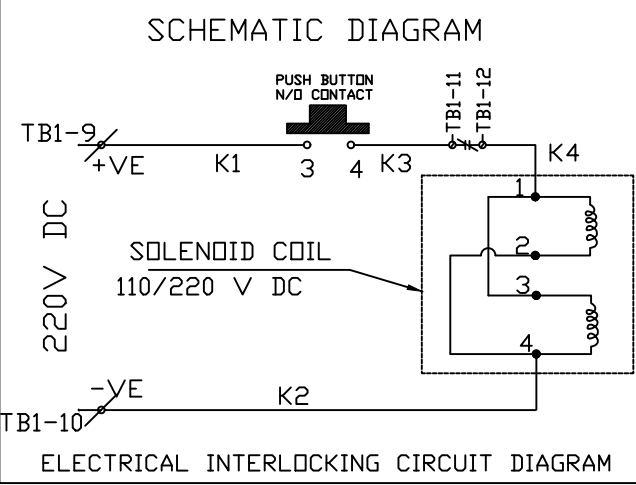
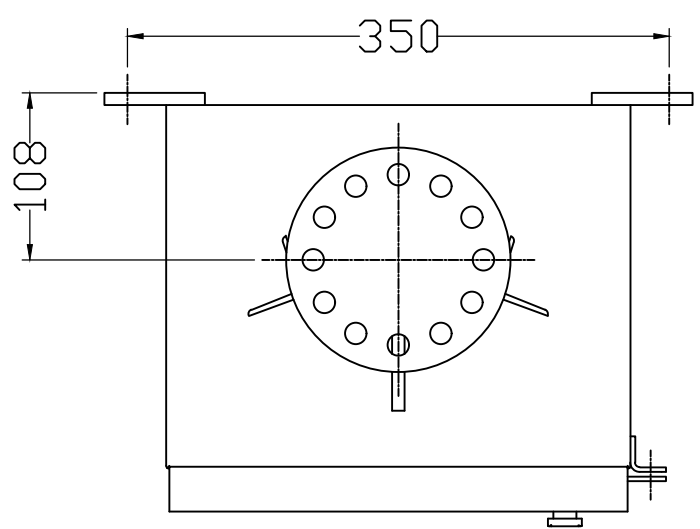

MAKE OF OPERATING BOX - TRITECH DISCON.	
SR.	DESCRIPTION
1	TOP FLANGE-8MM THK
2	ON-OFF STOPPER
3	BOX (AL-3 MM THK.)
4	DOOR WITH GASKET NEOPRENE 3MM THK.
5	AUX SWITCH (4NO + 4NC)
6	PROVISION FOR PADLOCK (WITHOUT LOCK)
7	TERMINAL BLOCK 2.5SqMM STUD TYPE
8	EARTHING TERMINAL
9	REMOVABLE GLAND PLATE
10	SOLENOID COIL 220V DC
11	PUSH BUTTON
12	REDUCTION GEARBOX

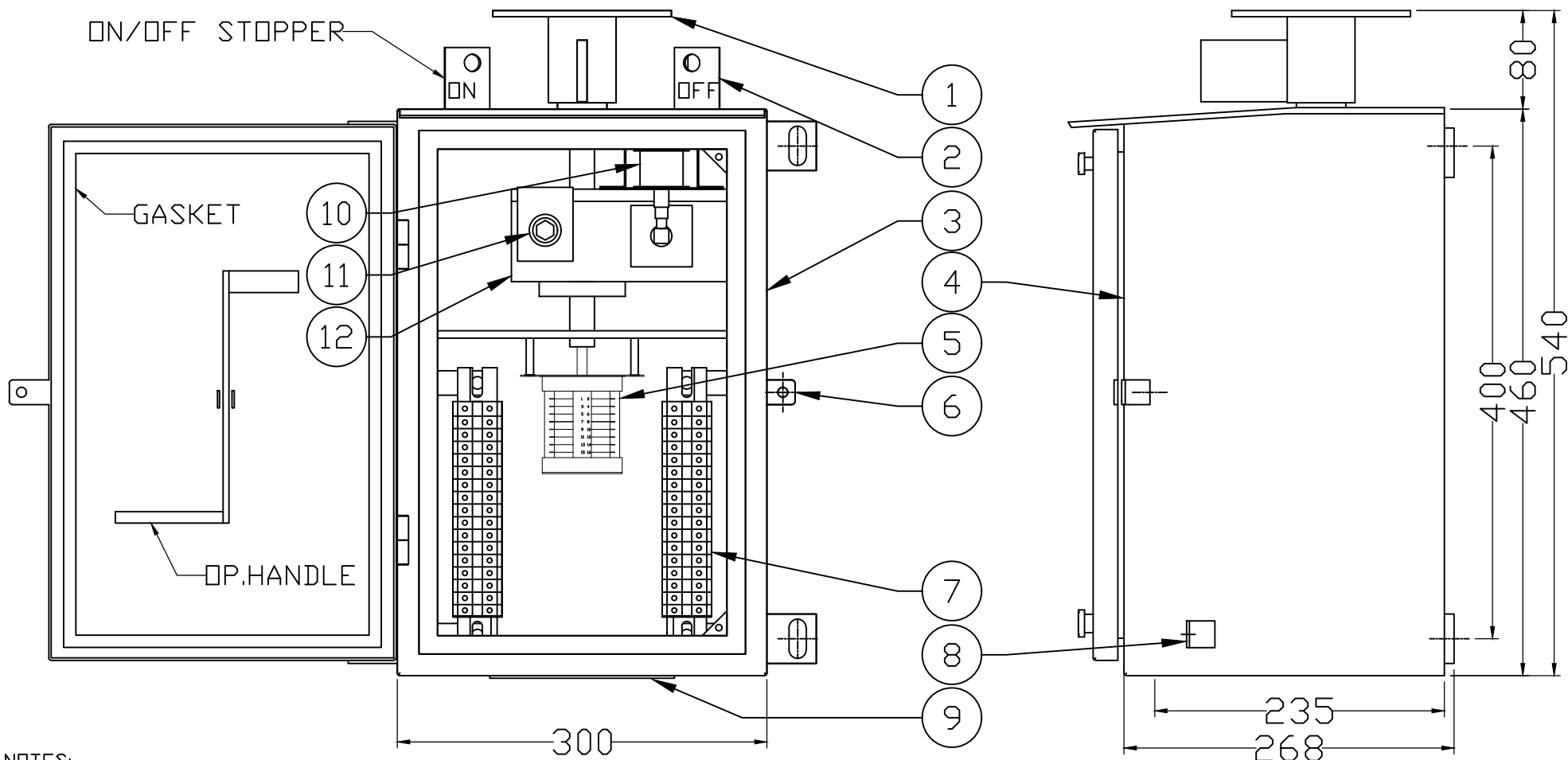

AUXILIARY CONTACTS 4NO+4NC

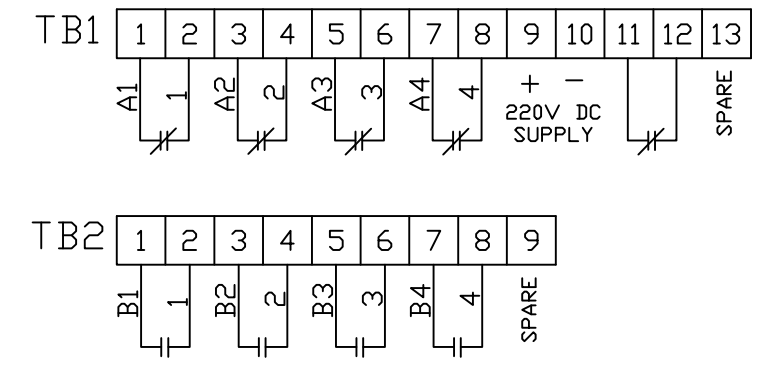

CHIEF ENGINEER/PROJECTS
APTRANSCO/VS/Vijayawada

Drawing approval subject to valid vendor registration

- NOTES:
- ALL DIMENSIONS ARE IN MM.
 - DEGREE OF PROTECTION IP-55.
 - POWDER COATING SHADE OF BOX= LIGHT GRAY (LG 631) THK- 80 MICRONS
 - MANUFACTURING TOLERANCES: ±5%
 - TERMINAL SHALL BE STUD TYPE SUITABLE FOR RING TYPE LUG PROVIDED
 - 20% SPARE TERMINALS PROVIDED FOR CUSTOMER USE.
 - WIRING WILL BE DONE WITH 1100 V. GRADE WITH 2.5 SQ.MM CU. STRANDED P.V.C. INSULATED CONDUCTOR
 - MATERIAL- 3MM THK ALUMINIUM

REV NO	DATE	DESCRIPTION	SIGN	REV. NO.	SIZE	SHEET	SCALE	
				00	A4	1/1	1:1	

TRITECH DISCONNECTORS (INDIA) PVT. LTD.
DISCONNECTORS (INDIA) PVT.LTD
MANUFACTURER OF HV/ EHV ISOLATORS

NAME	SIGN	DATE	TITLE
DRWN SHARAD	SRD	06.04.23	G.A. DRAWING OF REDUCTION GEAR MANUAL OPERATING BOX FOR MAINS
CHKD P JADHAV	P.J	06.04.23	
APPD P JADHAV	P.J	06.04.23	

DWG. NO : BRD08RG0AP

GTP-33KV 2000A WITHOUT EARTH SWITCH ISOLATOR

Sr. No.	Description	Particulars
1)	Type/Installation	DBCR,OUTDOOR TYPE
2)	Manufacturer's Name and Country of Manufacture	TRITECH DISCONNECTORS (INDIA) PVT LTD ,INDIA
3)	Standards according to which the isolators are manufactured	IS 9921,IEC129
4)	Maximum design voltage at which the isolator can operate (kV)	36 KV
5)	Frequency (Hz)	50 HZ
6)	Rated Voltage (kV)	33 KV
7)	Maximum current that can be safely interrupted by the isolator	
a)	Inductive (A & % PF)	0.7 A@0.15 PF
b)	Capacitive (A & % PF)	0.7A@0.15PF
8)	Continuous current rating Nominal (Amps) Under site conditions (Amps)	2000 AMPS
9)	Rated short time current	
a)	For 3 seconds (kA rms)	25 KA RMS
b)	For 1 second (kA rms)	-
c)	Rated peak short time current (kVp)	63 KAP
10)	Current density at the minimum cross-section of	2000
a)	Moving blade (Amps/Sq.mm)	2.0
b)	Terminal pad	AL 1.0
c)	Contacts	1.6
d)	Terminal Connector	1
11)	Maximum Temp. rise of current carrying parts when carrying rated current continuously (deg.c)	WITHIN LIMITS OF IS/IEC-9921
12)	Derating factor for specified site conditions	UNITY
13)	Insulation Levels	
a)	Impulse withstand voltage (kV peak) Phase to Earth & Isolating Distance	170 KV/195 KVP
b)	Switching surge withstand voltage (kV peak) Phase to Earth & Isolating Distance	NOT APPLICABLE
c)	Power Frequency withstand voltage (kV rms) Phase to Earth & Across isolating Distance	70/80 KV RMS FOR 1MINUTE
14)	Minimum clearance in air:	
a)	Between poles (mm)	1100MM FOR PHASE SPACING OF 1300 MM.
b)	Between live parts and earth (mm)	508MM
c)	Between live parts when switch is open:	
i)	On the same pole (mm)	715 MM FOR POLE SPACING OF 915 MM.
ii)	Between adjacent poles (mm)	1100MM
15)	Rated mechanical terminal load	
a)	Load along the terminal connector side (kg.)	NOT ASSIGNED IN IS/IEC

	b) Load across the terminal connector side (kg.)	NOT ASSIGNED IN IS/IEC	
16)	Torque required to operate the switch in Kgm (Not specified)	MAIN-35KGM,EARTH-35 KGM	
17)	Contact Zone		
a)	Horizontal deflection (mm)	NOT APPLICABLE FOR DOUBLE BREAK ISO.	
b)	Vertical deflection (mm)	-----D0-----	
c)	Total amplitude of longitudinal movement w.r.t. conductor supporting fixed contact (mm)	-----DO-----	
18)	Design and Construction		
a)	No. of insulators per pole	THREE STACKS/POLE	
b)	No. of breaks per pole	MAIN-2	
c)	Type of closing /Opening mechanism (Horizontal/Vertical break straight etc.)	MAIN-HORIZONTAL	
d)	Contacts:	<u>MAINS</u>	<u>E/S</u>
	i) Material and grade	CU	NA
	ii) Cross-sectional area (Sq.mm)	1280	NA
e)	Moving Blades:	<u>MAINS</u>	<u>ENA</u>
	i) Material and grade	CU	NA
	ii) Cross-sectional area (Sq.mm)	1055	NA
f)	Contact Support:		
	i) Material and size of channel/block	MS HDG, 4MM	
	ii) Material and size of plate	MS HDG., 6MM	
g)	Rain hood - Material grade and size	MS HDG , 5MM	
h)	Turn and twist mechanism		
	i) Material and size of clamps	MS HDG, 6MM	
	ii) Material size of springs	SS, 2.64 MM DIA	
	iii) Whether springs are encased	YES	
i)	Nuts and Bolts:		
	i) Size, material and grade in live parts	LESS THAN 3/8" SS, ABOVE 5/8" HDG	
	ii) Size, material and grade in other parts	3/8" ABOVE HDG	
j)	Insulator base plate Material and size of plate below insulators	MS HDG-10MM	
k)	Bearings:		
	i) Material and size of housing	AL ALLOY SUITABLE FOR 25 MM DIA SHAFT	
	ii) No. of bearings, location and size	2, BELOW ROTATING INSULATOR STACK.	
l)	Tandem pipe:		
	i) Size, length, class and no. of pipes	NB25,CL B,GI PIPE-3.5 M	
	ii) Size of shackle, screw	-	
	iii) No. of bearings/bush and its material and size	BRASS BUSH.	
m)	Type of interlock	MECHANICAL.	
n)	Down pipe size, length and class	40 NB,CL B,GI PIPE	
o)	Type of universal/swivel joint		
	i) Between bearing and down pipe	UNIVERSAL.	
	ii) Between down pipe and operating mechanism	VERNIER TYPE	
p)	Operating mechanism:	MAINS- RED GEAR	
	i) Control cabinet		

NOTE:-1. Drawings approval subject to valid type test reports,

7406051/2023/EEMRT-ENE51 to be checked during acceptance tests.

2. For EPC contractors only.

	Material and thickness	3MM THK ALUMINIUM
	Degree of protection	IP 55
	Type size and No. of cable glands	CONTRACTORS SCOPE
	Whether removable gland plate provided	YES
q)	Base:	
	i) Size of steel sections used	100X50X5 MM FORMED
	ii) Overall size	100X50X5X1070 MM
	iii) Total weight	8.50 KG /POLE
r)	Aux switch	4NO / 4NC CONTACT FOR MAINS SWITCH 10A,DC breaking with 2A - 1 No.
s)	Terminal blocks	M3 Stud type TB
t)	Insulated Wires	1100 V grades, 2.5 Sq.mm PVC For Auxiliary Circuit and 2.5 Sq.mm for Power circuit

1. Minimum 300mm plinth shall be maintained for CT/PT/CVT/ Isolators/IVT in the substation during foundation works to ensure safe live to ground clearance as per IE rules.
2. Since the supply of terminal connectors is not in the scope of manufacturers as mentioned in the drawings. The EPC contractors shall be instructed to supply the same in line with CT/PT/CVT/Isolator /IVTs requirement and compatibility.

CHIEF ENGINEER/PROJECTS
APTRANSCO/VS/Vijayawada

Drawing approval subject to valid vendor registration