

REPORTS, TO BE CHECKED DURING ACCEPTANCE TESTS
2. FOR EPC CONTRACTS ONLY

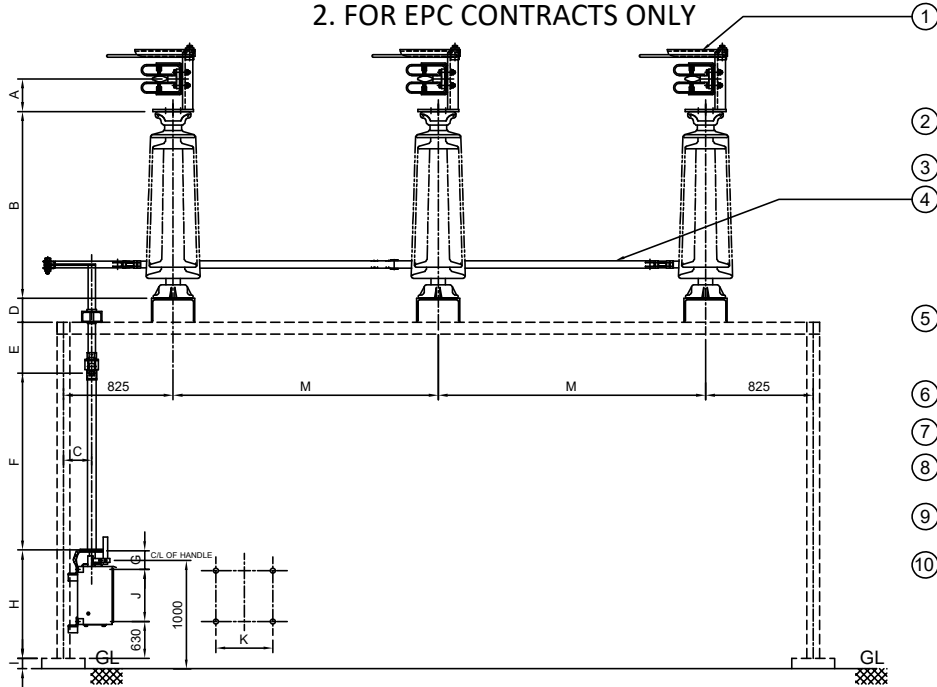

ELEVATION

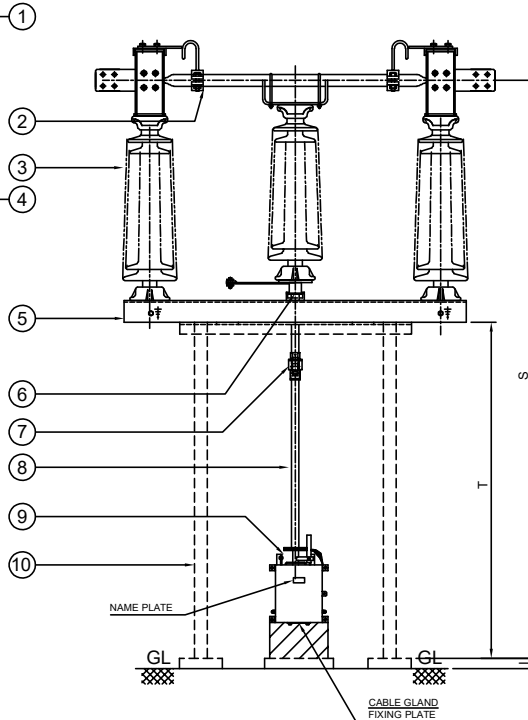

END VIEW

BASE FIXING DETAILS

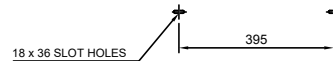

INSULATOR DETAILS

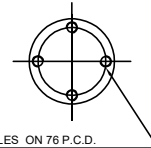

4 Nos. M12 TAP HOLES ON 76 P.C.D.

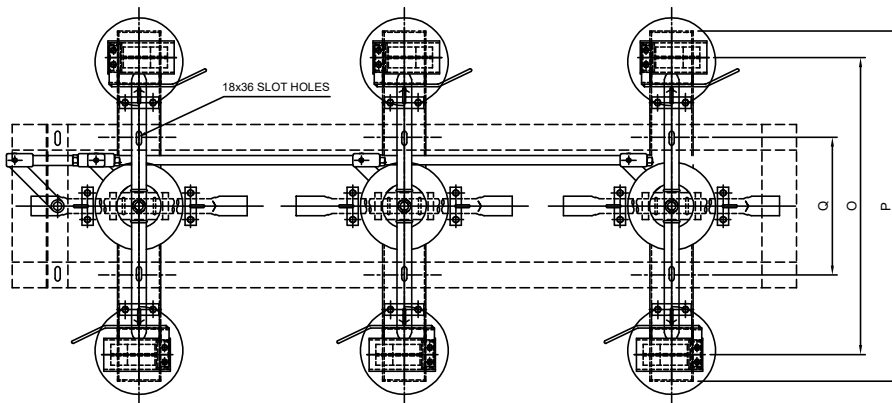

PLAN

PART LIST:

1. FIXED CONTACT ASSEMBLY
2. MOVING CONTACT ASSEMBLY
3. INSULATOR STACK (NOT IN OUR SCOPE OF SUPPLY)
4. PHASE COUPLING (25 NB, CLASS " B " GI PIPE)
5. BASE CHANNEL (100 x 50 x 5 mm THK.)
6. ROTATING STOOL BASE WITH LEVER ARM & CLAMP
7. UNIVERSAL JOINT ARRANGEMENT (M.S. HOT DIP GALVANIZED)
8. DOWN OPERATING PIPE(40 NB, CLASS " B " GI PIPE)
9. OPERATING MECHANISM (MANUAL)
10. SUPPORTING STRUCTURE (NOT IN OUR SCOPE OF SUPPLY)

REFERENCE DRAWINGS :

FOR MAIN CONTACT ASSEMBLY (1200A)----- 4. CRM APT 02
FOR MANUAL OPERATING MECH FOR M.S. ----- 4. CN APT 03
FOR NAME PLATE DETAILS ----- 4. CZ APT 04

Thickness of Silver plating : 15 Microns Minimum

NOTES:

1. ALL DIMENSIONS ARE IN MILLIMETERS
2. ALL FERROUS PARTS ARE HOT DIP GALVANIZED (87 MICRONS)
3. ALL NON FERROUS CONTACT POINTS ARE SILVER PLATED (8 MICRONS)
4. THE INDICATED DIMENSIONS ARE SUBJECT TO THE MANUFACTURING TOLERANCE:
UP TO 50 mm $\pm 3\%$; 51 TO 100 mm $\pm 2\%$;
101 TO 300 mm $\pm 1\%$; ABOVE 300 mm $\pm 0.5\%$;
5. SHORT TIME CURRENT RATING 25 KA rms. FOR 3 Sec.
6. APPLICABLE STANDARD : IS / IEC 62271 - 102
7. SUPPORT STRUCTURE & INSULATORS INCLUDING FIXING HARDWARE NOT IN OUR SCOPE OF SUPPLY

WEIGHT:

NET WEIGHT OF THE ISOLATOR
EXCLUDING INSULATOR : 210 Kgs. (Approx.)

DIMENSIONS

A	B	C	D	E	F	G	H	I	J	K	M
130	508	300	50	175	2725	NA	1000	300	NA	NA	1300
N	O	P	Q	R	S	T	U	W			
NA	915	1020	395	NA	4588	3900	NA	NA			

REVISIONS			
D	C	B	A

TITLE:
**33 kV, 1200 A, T.P, DB, BT,
ISOLATOR WITH OUT E.S.**

GR POWER SWITCHGEAR LTD.,
JEDIMETLA HYDERABAD-500 055 INDIA

SCALE:N.T.S	
DATE	21-03-2023
DRAWN	
CHECKED	
APPROVED	
DRG.NO:	3.CJ APT 01
REV	

Drawing approval subject to valid vendor registration

**Chief Engineer/Projects
APTRANSCO/VS/Vijayawada.**

FIXED CONTACT ASSEMBLY:

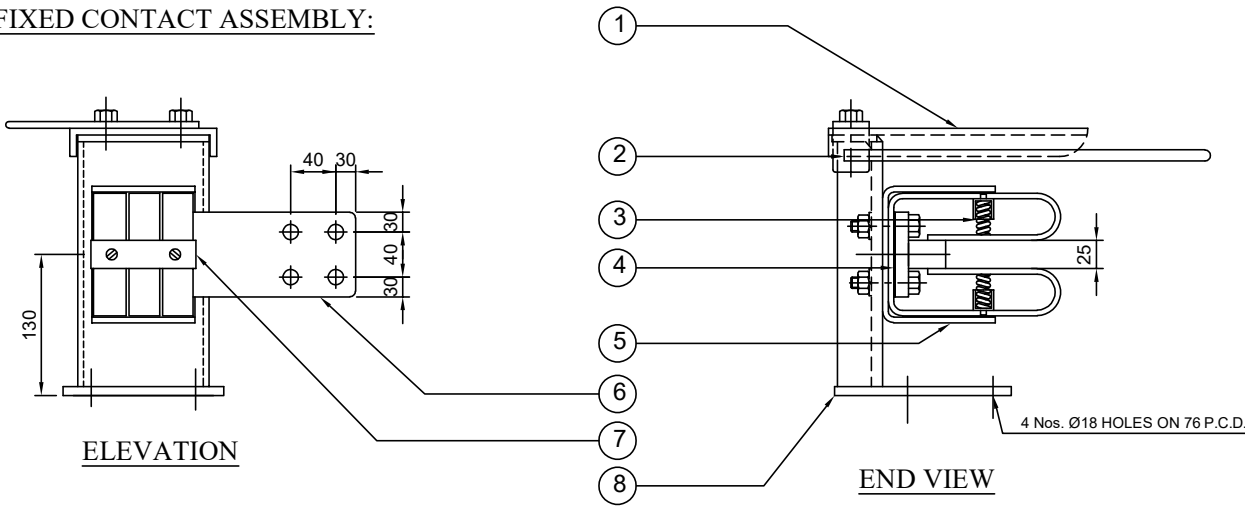

PART LIST:

1. HOOD (M.S.HDG)
2. ARCING HORNS (Ø10 ROD M.S.HDG)
3. SPRINGS (STAINLESS STEEL)
4. BI-METALLIC SHEET (2 mm THICK Alu. + Cu.)
5. JAWS (32 x 4 Cu. FLAT 3 Nos. SILVER PLATED)
6. JUMPER PLATE (100 x 12 mm THICK ALUMINUM FLAT)
7. SPACER (ALUMINUM)
8. SUPPORTING CHANNEL (M.S.HDG)
9. MOVING CONTACT (50 OD x 41 ID. HDEC TUBE) ENDS SILVER PLATED
10. CENTER MECHANISM (M.S.HDG)

MOVING CONTACT ASSEMBLY

Drawing approval subject to valid vendor registration

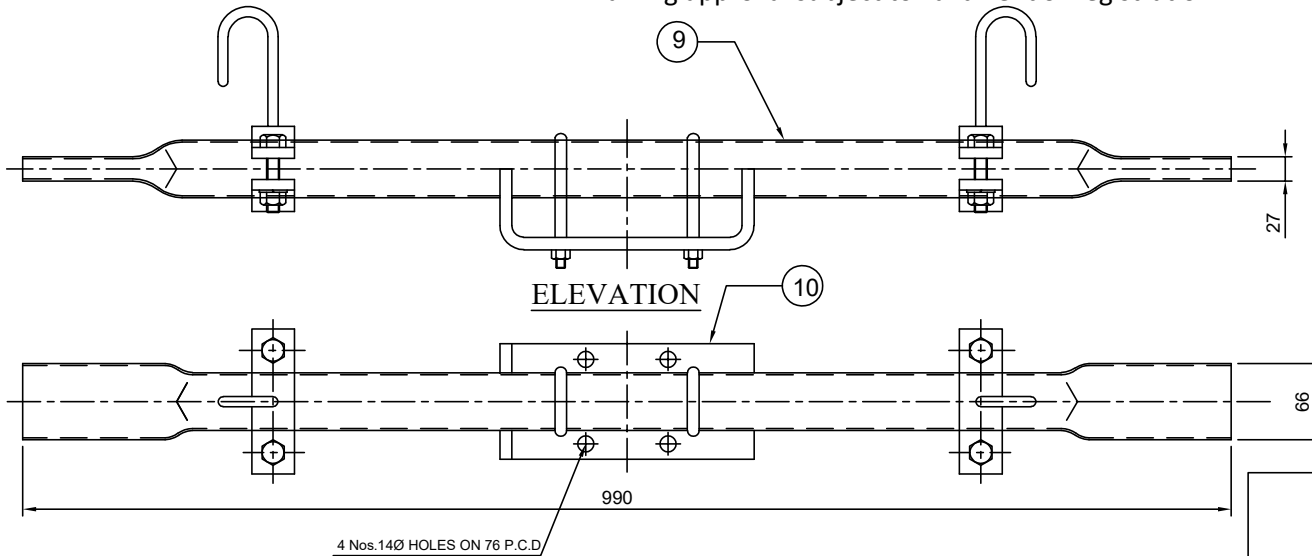

NOTE: Thickness of Silver plating : 15 Microns Minimum

1. ALL DIMENSIONS ARE IN MILLIMETER
2. ALL FERROUS PARTS ARE HOT DIP GALVANIZED
3. ALL NON FERROUS CONTACT POINTS ARE SILVER PLATED (MICRONS)
4. THE MOVING CONTACT ASSEMBLY SHOWN IS FOR BANGING TYPE ASSEMBLY

NOTE: 1. DRAWING APPROVAL SUBJECT TO VALID TYPE TEST REPORTS, TO BE CHECKED DURING ACCEPTANCE TESTS
2. FOR EPC CONTRACTS ONLY

**Chief Engineer/Projects
APTRANSCO/VS/Vijayawada.**

REVISIONS			
D	C	B	A

TITLE:
**MAIN SWITCH CONTACT ASSEMBLY
(FOR 33 KV 1200 AMPS)**

SCALE:N.T.S.	
DATE	27-03-2023
DRAWN	
CHECKED	
APPROVED	
DRG.NO:	4. CJM APT 02
REV	



**GR POWER SWITCHGEAR LTD.,
JEEDIMETLA HYDERABAD-500 055 INDIA**

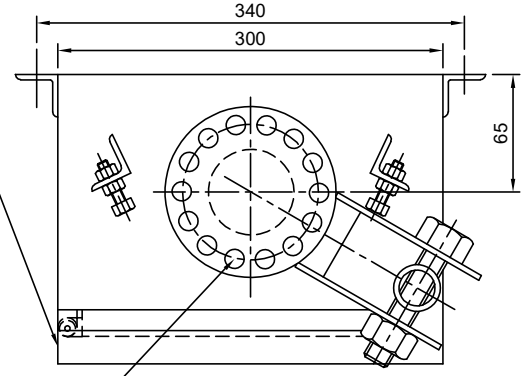
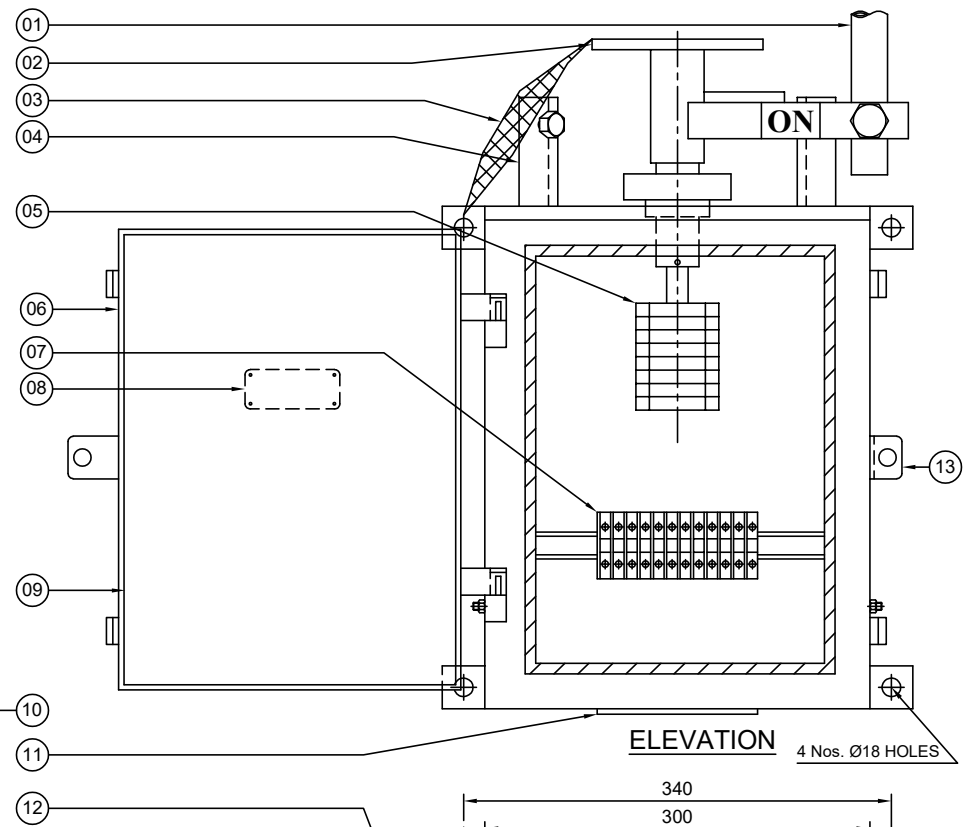
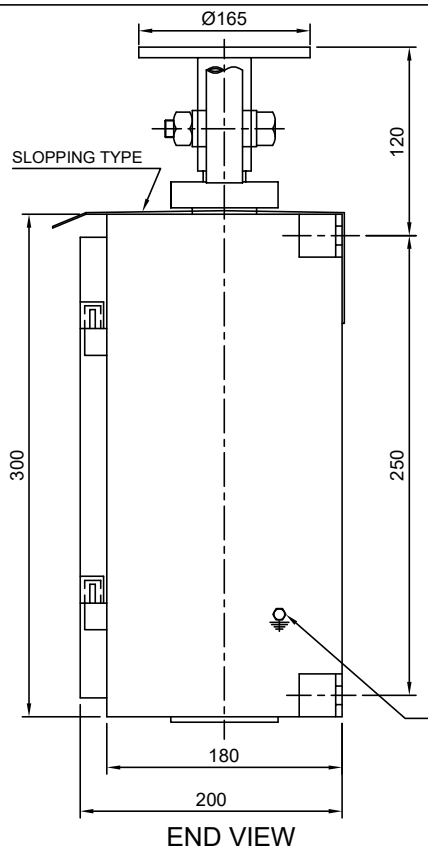

AUX. SWITCH CONTACT DETAILS
(4 NO + 4 NC)

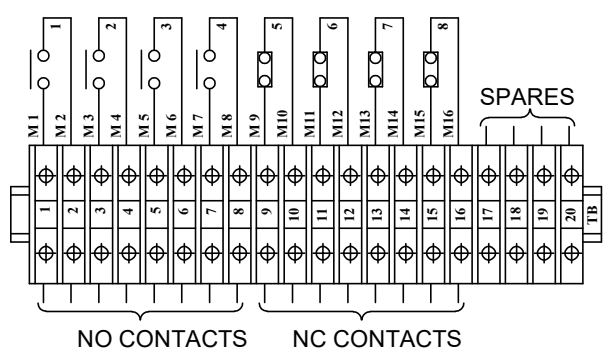

14 NOS. Ø18 HOLES
ON 127 PCD

Drawing approval subject to valid vendor registration

PART LIST

01. OPERATING HANDLE (Ø32 G.I. PIPE, 600 mm LONG)
02. OUTPUT FLANGE (8 MM THICK, M.S.PLATE)
03. COPPER FLEXIBLE (2 Nos. 25 x 3 mm TINNED Cu. FLEXIBLE)
04. ON - OFF STOPPER
05. AUXILIARY SWITCH (4 NO / 4 NC, 10 A SILVER PLATED)
06. CUBICLE WITH DOOR (3 mm THICK, ALU. SHEET)
07. TERMINAL BLOCK (UBT - 4 OF ELEM X / VINMECH OR ITS EQVT.)
08. NAME PLATE
09. GASKET (EPDM)
10. PROVISION FOR EARTHING TERMINAL
11. DETACHABLE CABLE GLAND FIXING PLATE (WITHOUT GLANDS)
12. RAIN SHADE
13. PROVISION FOR PAD LOCK WITHOUT KEY

NOTES:

1. ALL DIMENSIONS ARE IN MILLIMETER
2. CUBICLE WILL BE NATURAL ALUMINIUM FINISH
3. DEGREE OF PROTECTION IP:55 AS PER IS/IEC 60529
4. WEIGHT OF THE BOX : 18 Kg (Approx.)
5. 20% SPARE TERMINALS PROVIDED
6. WIRING WILL BE DONE WITH 1100 V. GRADE
a) FOR AUXILIARY CIRCUIT (DC SUPPLY) : 2.5 Sq.MM Cu. STRANDED P.V.C. INSULATED CONDUCTOR

Chief Engineer/Projects
APTRANSCO/Vs/Vijayawada.

NOTE: 1. DRAWING APPROVAL SUBJECT TO VALID TYPE TEST REPORTS, TO BE CHECKED DURING ACCEPTANCE TESTS
2. FOR EPC CONTRACTS ONLY

REVISIONS			
D	C	B	A

TITLE:	MANUAL OPERATING MECHANISM FOR MAIN SWITCH (33 KV, 1200 A)
SCALE:N.T.S	
DATE	21 - 03 - 2023
DRAWN	
CHECKED	
APPROVED	
DRG.NO:	4. CN APT 03
REV	



GR POWER SWITCHGEAR LTD.,
JEEDIMETLA HYDERABAD-500 055 INDIA

NAME PLATE DETAILS FOR ISOLATOR

 MANUFACTURED & SUPPLIED BY GR POWER SWITCHGEAR LTD., JEEDIMETLA, HYDERABAD - 500 055	
CUSTOMER :	M/s. TRANSMISSION CORPORATION OF AP LIMITED
PROJECT :	
CONTRACTOR :	
P.O. NO :	
TYPE :	HDB
SL. NO :	AS APPLICABLE
YEAR OF Mfg. :	
RATING : Un	33 KV ; In : 1200 A ; WEIGHT IN KG :
IMPLUSE(UI) :	170 KV Peak; SWITCHING(Us): NA KV Peak;
P.F. :	70 KV rms; STC(lth): 25 KA rms; DURATION: 3 Sec;
OPERATING MECHANISM :	LEVER / MANUAL
CONTROL VOLTAGE :	NA
Control voltage 220V DC	
150	

NOTE: 1. DRAWING APPROVAL SUBJECT TO VALID TYPE TEST REPORTS, TO BE CHECKED DURING ACCEPTANCE TESTS
2. FOR EPC CONTRACTS ONLY

Chief Engineer/Projects
APTRANSCO/VS/Vijayawada.





Project, contractor, PO, date ,year of MFG shall be stamped during inspection

1. Minimum 300mm plinth shall be maintained for CT/PT/CVT/ Isolators/IVT in the substation during foundation works to ensure Safe live to ground clearance as per IE rules.
2. since the supply of terminal connectors is not in the scope of Manufacturer as mentioned in the drawings. The EPC contractor Shall be instructed to supply the same in line with CT/PT/CVT/Isolator /IVTs requirement and compatibility.

NOTES :

1. ENGRAVED LETTER SIZE : 3 mm
2. LETTER ETCHED WHITE ON BLACK BACKGROUND
3. MATERIAL : ALUMINIUM
4. THICKNESS : 1 mm

Drawing approval subject to valid vendor registration

<table border="1"> <tr> <th colspan="4">REVISIONS</th> </tr> <tr> <th>D</th> <th>C</th> <th>B</th> <th>A</th> </tr> <tr> <td> </td> <td> </td> <td> </td> <td> </td> </tr> <tr> <td> </td> <td> </td> <td> </td> <td> </td> </tr> </table>	REVISIONS				D	C	B	A									TITLE: NAME PLATE DETAILS (FOR 33 KV)	SCALE:N.T.S	
	REVISIONS																		
	D	C	B	A															
DATE	21/03/2023																		
DRAWN																			
CHECKED																			
APPROVED																			
DRG.NO:	4. CZ APT 04	REV																	
 GR POWER SWITCHGEAR LTD., JEEDIMETLA HYDERABAD-500 055 INDIA																			

SCHEDULE OF GUARANTEED TECHNICAL PARTICULARS FOR 33 KV, 1200A WITHOUT EARTH SWITCH

S.No	DESCRIPTION		33 KV
1	Type/Installation	:	"DB" Double Break - OUTDOOR
2	Manufacturer's Name and country of manufacture	:	GR POWER SWITCHGEAR LTD.,
3	Standards according to which the isolators are manufactured.	:	IS 9921Part I to V & IEC 62271-102
4	Maximum design voltage at which the isolator can operate (kV).	:	36 KV
5	Frequency (Hz)	:	50 Hz
6	Rated voltage (kV)	:	33 KV
7	Maximum current that can be safely interrupted by the Isolator inductive (A & % PF) Capacitive (A & % PF)	:	0.7 Amps at 0.15 p.f.
8	Continuous current rating normal (Amps) under site conditions (Amps).	:	1200 Amps
9	Rated short time current		<u>MAIN SWITCH</u>
	i) For 3 Seconds (kA rms)	:	25 KA rms
	ii) For 1 Second (kA rms)	:	Not Applicable
	iii) Rated peak short time current (KV P)	:	62.5 KA rms
10	Current density at the minimum cross section of		
	a) Moving blade (Amps/Sq.mm)	:	2.0 Amps/Sq.mm for HDE Cu. Tube
	b) Terminal pad	:	1.0 Amp/Sq.mm for EC grade Alu. Flat.
	c) Contacts	:	1.6 Amps/Sq.mm for HDE Cu. Flat.
11	Maximum temperature rise of current carrying parts when carrying rated current continuously (Deg.C).	:	Within the specified limits of IS/IEC 62271-102
12	Insulation levels		
	i) Impulse withstand voltage (kV Peak) Phase to Earth Isolating Distance.	:	170/195 KV Peak
	ii) Switching surge withstand voltage (kV Peak) Phase to Earth isolating distance.	:	Not applicable

**Chief Engineer/Projects
APTRANSCO/VS/Vijayawada.**

S.No	DESCRIPTION	33 KV
	iii) Power Frequency withstand voltage (kV rms) Phase to Earth isolating distance.	70/80 KV rms
13	Minimum clearance in air	
	i) Between poles (mm)	1000 mm for a phase spacing of 1300 mm
	ii) Between live parts and earth (mm)	450 mm
	iii) Between live parts when switch is open.	
	a) On the same pole (mm)	715 mm
	b) Between adjacent poles (mm)	1050 mm
14	Rated mechanical terminal load	
	i) Load along the terminal connector side (Kg).	Not Applicable as per IS/IEC
	ii) Load across the terminal connector side (Kg).	Not Applicable as per IS/IEC
15	Torque required to operate the switch in Kg.m.	36 Kg m
16	Contact Zone	
	i) Horizontal deflection (mm)	
	ii) Vertical deflection (mm)	Not applicable
	iii) Total amplitude of longitudinal movement w.r.t conductor supporting fixed contact	
17	Design and construction	
	i) No. of insulators per pole	Three
	ii) No. of breaks per pole	Two
	iii) Type of closing / opening mechanism (Horizontal / vertical break straight etc.).	Horizontal break for Isolator
	iv. Contacts	
	a) Material and grade	Thickness of Silver plating : 15 Microns Minimum Hard Drawn Electrolytic Copper flat, silver plated  micron thickness.
	b) Cross-sectional area (Sq.mm)	768 Sq.mm for 1200A

Chief Engineer/Projects
APTRANSCO/VS/Vijayawada.

GR POWER SWITCHGEAR LTD

S.No	DESCRIPTION	33 KV
v	Moving blades	
	a) Material and grade	: Thickness of Silver plating : 15 Microns Minimum Hard Drawn Electrolytic Copper tube, silver plated  micron thickness.
	b) Cross-sectional area (Sq.mm)	: 643 Sq.mm for 1200A
vi)	Contact support	
	a) Material and size of channel / block.	: 8 mm Thick MS HDG
vii)	Rain hood-material grade and size	: MS HDG
viii)	Banging Type mechanism	
	a) Material and size of clamps	: 6 mm thick M.S. Flat - HDG
	b) Material size of springs	: S.S Sheet
	c) Whether springs are encased	: Not encased
ix)	Nuts and bolts	
	a) Size, material and grade in live parts.	:
	b) Size, material and grade in other parts.	: M8 and above are of MS HDG.
x)	Insulator base plate material and size of plate below insulators.	: 6 mm thick M.S. Hot dip galvanised plate
xi)	Bearings	
	a) Material and size of housing	: MS HDG
	b) No. of bearings, location & size	: 1 No. below centre rotating post insulator
xii)	Tandem pipe	
	a) Size, length class and No. of pipes	: As per GA drawings
	b) Size of shackle screw	: Suitable for 25 NB
	c) No. of bearings / bush and its material and size.	: 6 Nos. bush bearings, brass, 16 mm ID Size.
xiii)	Type of interlock	: Not Applicable
	Drawing approval subject to valid vendor registration	

Chief Engineer/Projects
APTRANSCO/VS/Vijayawada.

S.No	DESCRIPTION		33 KV
xiv)	Down pipe size, length and class	:	40 mm NB Class B GI Pipe.
xv)	Type of universal/swivel joint		
	a) Between bearing & down pipe	:	Universal joint
	b) Between down pipe and operating mechanism.	:	Vernier Flange
xvi)	Operating mechanism		Manual operated mechanism for M.S
	a) Control cabinet		
	Material and thickness	:	3 Thick AL Sheet
	Degree of protection	:	IP : 55 as per IS 2147
	Type size and no. of cable glands.	:	Double compression type, 2 Nos. 19 mm. (Contractor scope of supply)
	Whether removable gland plate provided.	:	Yes, removable gland plate provided.
	b) Make type, rating and Qty. of Motors	:	Not Applicable
	Auxiliary blocks	:	4 NO / 4 NC contacts for Main Switch Mani 10 A, 2 A DC breaking with 2A - 1 No.
	Terminal blocks	:	UBT-4
	Insulated Wires	:	1100 V grades, 2.5 Sq.mm PVC
xvii)	Base		
	a) Size of steel sections used	:	100 x 50 mm
	b) Overall size	:	1060 x 100 x 50 mm x 5 mm
	c) Total weight	:	9 Kgs approx

for GR POWER SWITCHGEAR LTD.,

Drawing approval subject to valid vendor registration



AUTHORIZED SIGNATORY

Chief Engineer/Projects
APTRANSCO/VS/Vijayawada.