

NOTE: 1. DRAWING APPROVAL SUBJECT TO VALID TYPE TEST

REPORTS, TO BE CHECKED DURING ACCEPTANCE TESTS

2. FOR EPC CONTRACTS ONLY

**LIST OF 33 KV STD ISOLATOR DRAWINGS/DOCUMENTS**

7215498/2023/EEMRT-ENE51



**GR POWER SWITCHGEAR LIMITED**

PLOT NO:27/B IDA JEEDIMETLA

HYDERABAD

CUSTOMER :	SLNO.	DRG.NO.	REV	DESCRIPTION OF DRAWINGS/DOCUMENTS
M/s TRANSMISSION CORPORATION OF	1	3. CR APT 01,01A	0	33 KV , 2000 AMPS,TP,DB,RT,ISOLATOR WITH OUT E. S
ANDHRA PRADESH LIMITED	2	4. CRM APT 02	0	MAIN SWITCH CONTACT ASSEMBLY (2000 A)
	3	4. CN APT 03	0	MANUAL OPERATING MECHANISM FOR 33 KV M.S. (2000 A)
	4	4. CZ APT 04	0	NAME PLATE DETAILS FOR 33 KV M/S & E/S

**Chief Engineer/Projects  
APTRANSCO/VS/Vijayawada.**

PREPARED BY	CHECKED BY	APPROVED BY

NOTE: 1. DRAWING APPROVAL SUBJECT TO VALID TYPE TEST REPORTS, TO BE CHECKED DURING ACCEPTANCE TESTS  
2. FOR EPC CONTRACTS ONLY

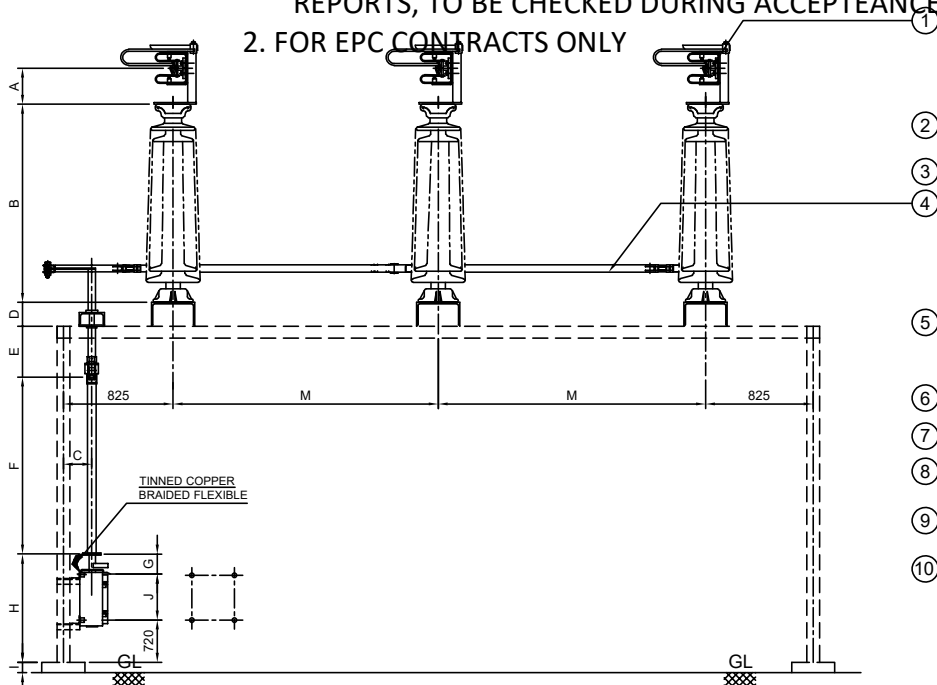

ELEVATION

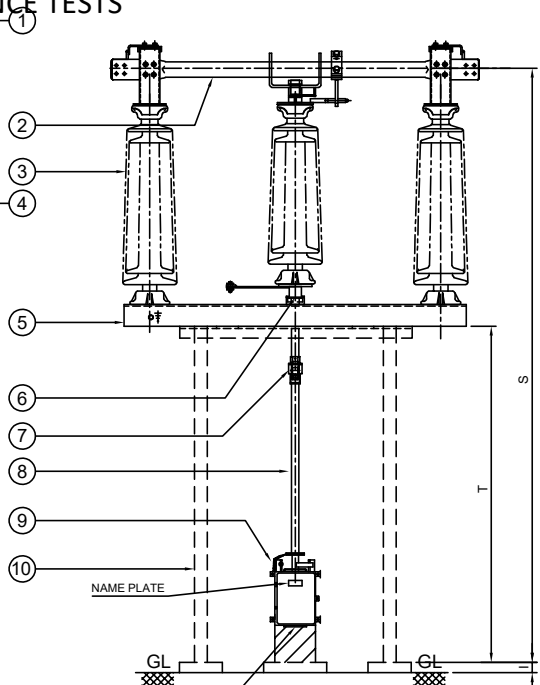

END VIEW

BASE FIXING DETAILS



INSULATOR DETAILS

4 Nos. M12 TAP HOLES ON 76 P.C.D.

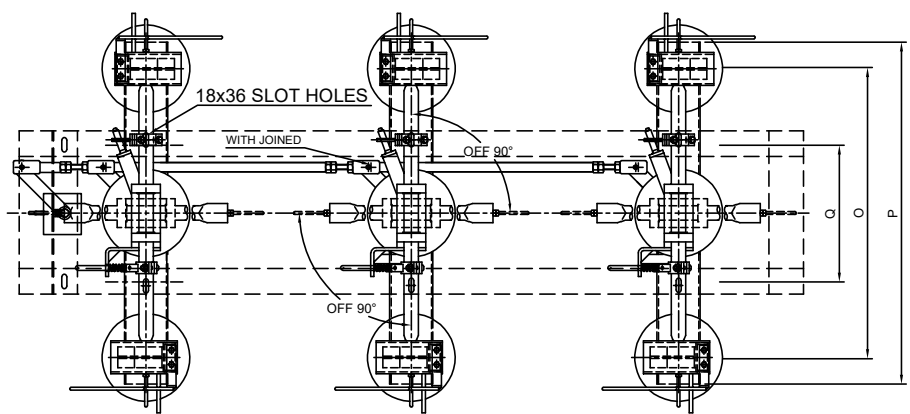

PLAN

Drawing approval subject to valid vendor registration

DIMENSIONS

A	B	C	D	E	F	G	H	I	J	K	M	N	O	P	Q	R	S	T	U	W
175	508	300	50	175	2725	120	1000	300	360	400	1300	NA	915	1020	395	NA	4633	3900	NA	NA

PART LIST:

164

721

- FIXED CONTACT ASSEMBLY
- MOVING CONTACT ASSEMBLY
- INSULATOR STACK (NOT IN OUR SCOPE OF SUPPLY)
- TANDEM PIPE (25 NB, G.I. PIPE)
- BASE CHANNEL (100 x 50 x 5 mm THICK CHANNEL)
- ROTATING STOOL BASE WITH LEVER ARM & CLAMP
- UNIVERSAL JOINT ARRANGEMENT (M.S. HOT DIP GALVANIZED)
- DOWN OPERATING PIPE (40 NB, G.I. PIPE)
- OPERATING MECHANISM (MANUAL)
- SUPPORTING STRUCTURE (NOT IN OUR SCOPE OF SUPPLY)

REFERENCE DRAWINGS :

- FOR MAIN CONTACT ASSEMBLY (2000A) ----- 4. CRM APT 02
- FOR MANUAL OPERATING MECH FOR M.S. ----- 4. CN APT 03
- FOR NAME PLATE DETAILS ----- 4. CZ APT 04

Thickness of Silver plating : 15 Microns Minimum

NOTES:

- ALL DIMENSIONS ARE IN MILLIMETERS
- ALL FERROUS PARTS ARE HOT DIP GALVANIZED (87 MICRONS)
- ALL NON FERROUS CONTACT POINTS ARE SILVER PLATED (8 MICRONS)
- THE INDICATED DIMENSIONS ARE SUBJECT TO THE MANUFACTURING TOLERANCE:  
UP TO 50 mm ---±3%; 51 TO 100 mm ---±2%;  
101 TO 300 mm ---±1%; ABOVE 300 mm ---±0.5%;
- SHORT TIME CURRENT RATING 25 KA rms. FOR 3 Sec.
- APPLICABLE STANDARD : IS / IEC 62271 - 102
- SUPPORT STRUCTURE & INSULATORS INCLUDING FIXING HARDWARE NOT IN OUR SCOPE OF SUPPLY

WEIGHT:

NET WEIGHT OF THE ISOLATOR EXCLUDING INSULATOR : 280 Kg. (Approx.)

**Chief Engineer/Projects**  
**APTRANSCO/VS/Vijayawada.**

REVISIONS	D	C	B	A

TITLE:  
**33 kV, 2000 A, TRIPLE POLE, DB, RT, ISOLATOR WITHOUT E.S. (PTR LV SIDE : 4633 mm)**

SCALE:N.T.S.	
DATE	21/03/2023
DRAWN	
CHECKED	
APPROVED	



**GR POWER SWITCHGEAR LTD.,**  
**JEEDIMETLA HYDERABAD-500 055 INDIA.**

DRG.NO:	3. CR APT 01	REV	
---------	--------------	-----	--

FIXED CONTACT ASSEMBLY:

NOTE: 1. DRAWING APPROVAL SUBJECT TO VALID TYPE TEST REPORTS, TO BE CHECKED DURING ACCEPTANCE TESTS  
2. FOR EPC CONTRACTS ONLY

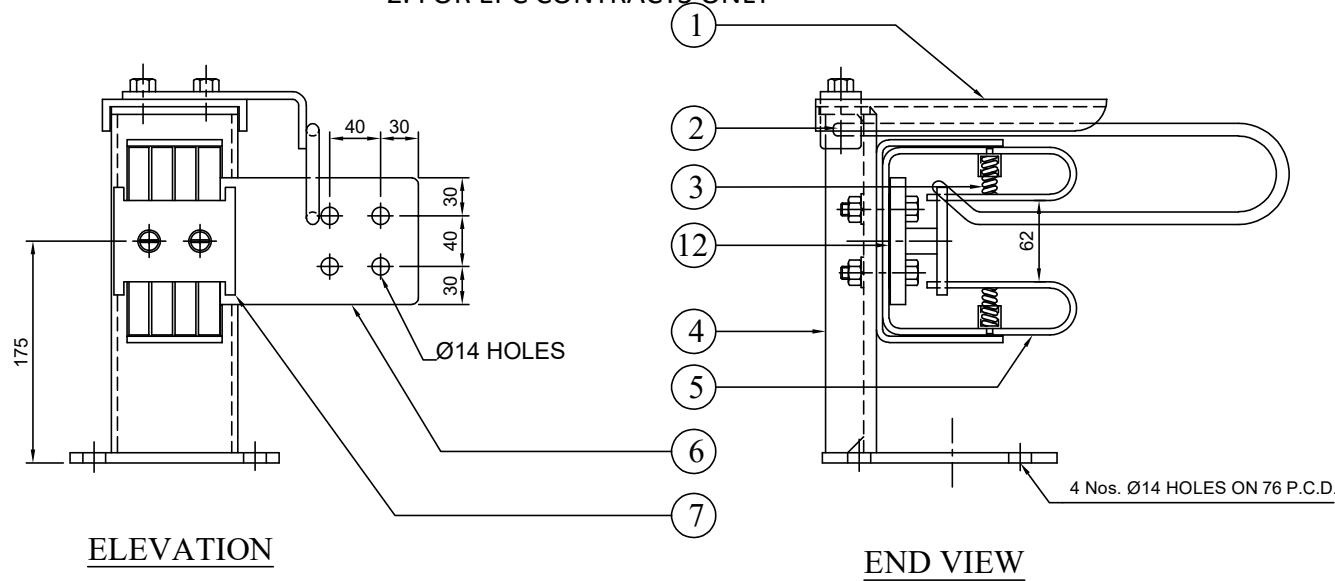

ELEVATION

END VIEW

MOVING CONTACT ASSEMBLY

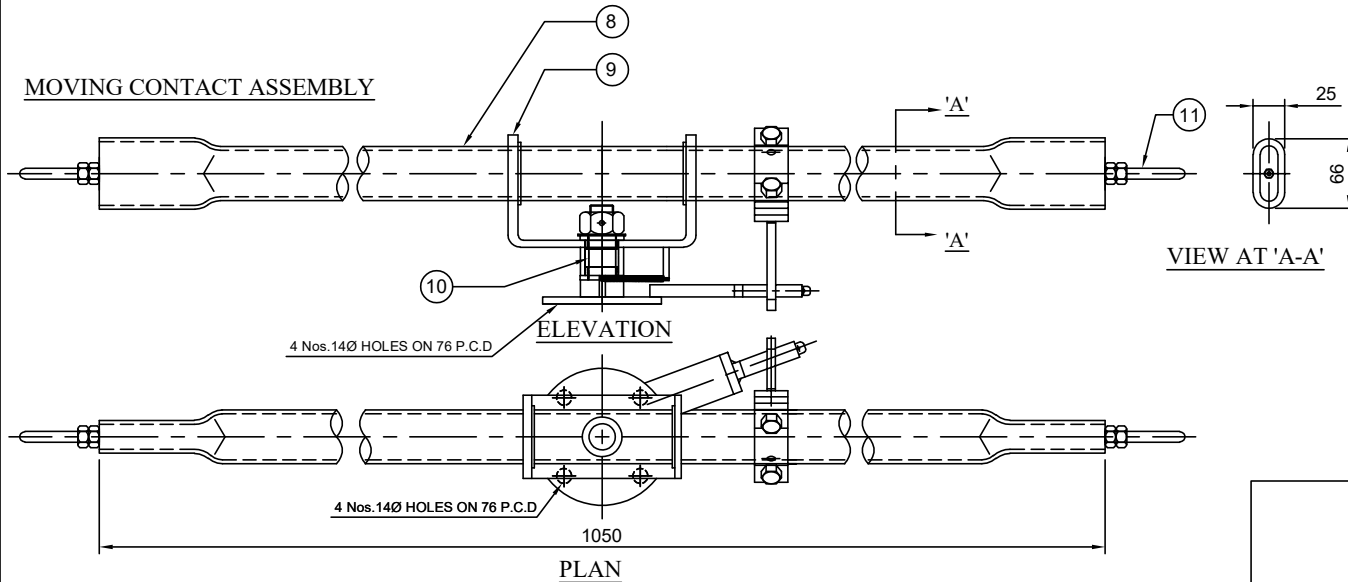

ELEVATION

PLAN

Drawing approval subject to valid vendor registration

PART LIST:

1. HOOD (18 SWG M.S. HDG)
2. ARCING HORNS (Ø10 ROD M.S. HDG)
3. SPRINGS (Ø2 mm STAINLESS STEEL.)
4. SUPPORTING CHANNEL (135 x 40 mm M.S. HDG)
5. JAWS (32 x 5 HDEC STRIP 4 Nos. SILVER PLATED)
6. JUMPER PLATE (100 x 20 ALU. FLAT)
7. SPACER (ALUMINUM)
8. MOVING CONTACT ARM (50 OD x 34 ID CU. TUBE )
9. MC SUPPORT WITH NYLON BUSH
10. CENTER MECHANISM (M.S. HDG, TURN & TWIST MECHANISM)
11. ARCING HORN FOR MOVING CONTACT(Ø10 ROD M.S. HDG)
12. BI-METALLIC SHEET (2 mm THICK Alu. + Cu.)

165	721
BOQ	
06 Nos	
06 Nos	
48 Nos	
06 Nos	
24 Nos	
06 Nos	
06 Nos	
03 Nos	
06 Nos	
03 Nos	
06 Nos	
06 Nos	

NOTE:

1. ALL DIMENSIONS ARE IN MILLIMETER
2. ALL FERROUS PARTS ARE HOT DIP GALVANIZED
3. ALL NON-FERROUS CONTACT POINTS ARE SILVER PLATED  
MICRONS REMAINING CONTACT AREA TIN PLATED.
4. THE MOVING CONTACT ASSEMBLY SHOWN FOR TURN & TWIST ASSEMBLY  
Thickness of Silver plating : 15 Microns Minimum

**Chief Engineer/Projects**  
**APTRANSCO/VS/Vijayawada.**

REVISIONS			
D	C	B	A

TITLE:  
**MAIN SWITCH CONTACT ASSEMBLY**  
(FOR 33 kV 2000 Amps)

**GR POWER SWITCHGEAR LTD.,**  
JEEDIMETLA HYDERABAD-500 055 INDIA

SCALE:N.T.S	
DATE	21/03/2023
DRAWN	
CHECKED	
APPROVED	
DRG.NO:	4. CRM APT 02
REV	

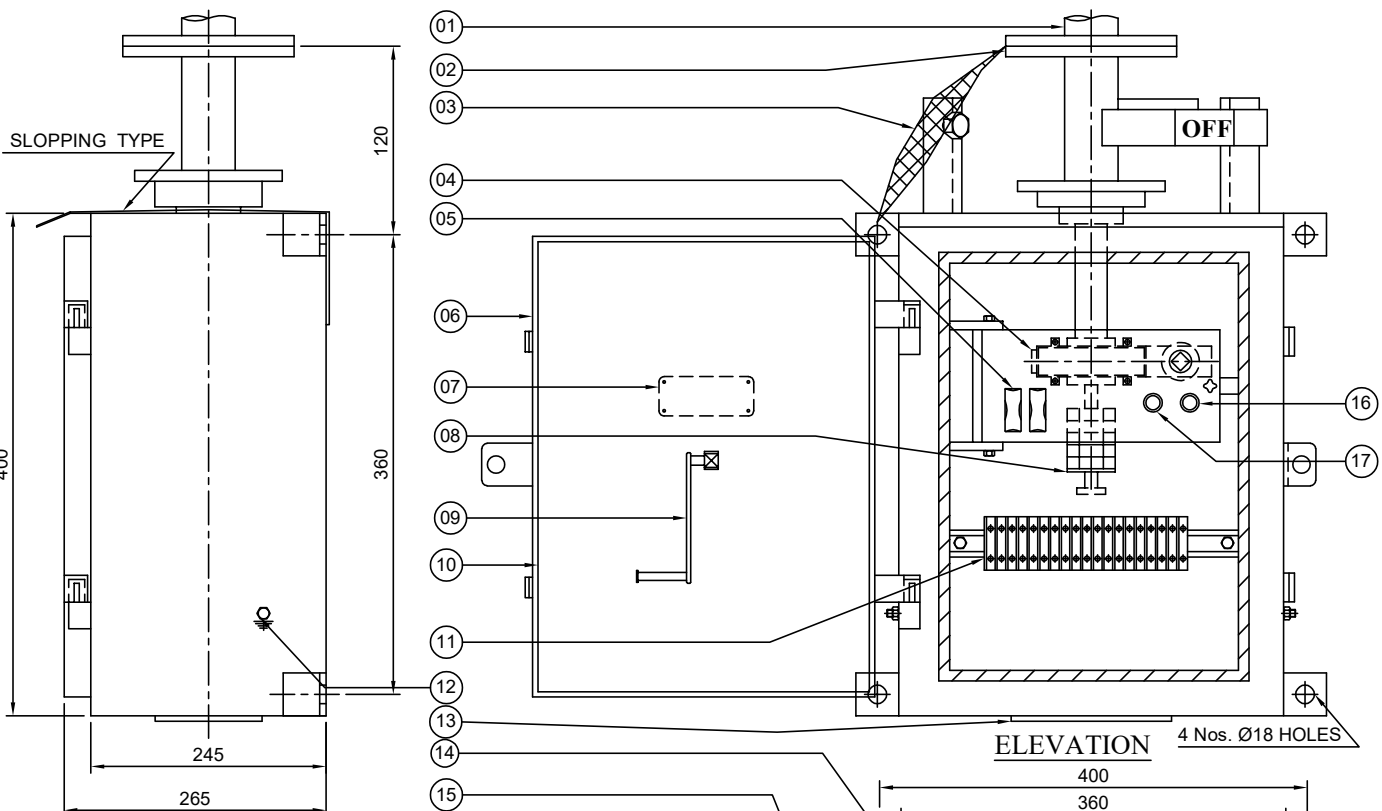

**PART LIST**

01. DOWN OPERATING PIPE
02. OUTPUT FLANGE (08 MM THICK M.S. PLATE)
03. COPPER FLEXIBLE (25 x 3 mm TINNED Cu. FLEXIBLE)
04. REDUCTION GEAR BOX (MATERIAL : EN8 / FORGED STEEL)
05. FUSES (2 A)
06. CUBICLE WITH DOOR (3 mm THICK, ALU. SHEET)
07. NAME PLATE
08. AUXILIARY SWITCH (4 NO + 4 NC)
09. OPERATING HANDLE
10. GASKET (EPDM)
11. TERMINAL BLOCKS (UBT - 4 OF ELEM X / VINMECH OR ITS EQVT.)
12. PROVISION FOR EARTHING TERMINALS
13. DETACHABLE CABLE GLAND FIXING PLATE (WITHOUT GLANDS)
14. ON - OFF STOPPERS (M.S. ANGLE PAINTED)
15. RAIN SHADE
16. INDICATION LAMP
17. PUSH BUTTON (4 A)

**NOTES:**

1. ALL DIMENSIONS ARE IN MILLIMETER
2. CUBICLE WILL BE NATURAL ALUMINIUM FINISH
3. DEGREE OF PROTECTION IP:55 AS PER IS/IEC 60529
4. WEIGHT OF THE BOX :28 Kg (Approx.)
5. WIRING WILL BE DONE WITH 1100 V GRADE 2.5 Sq. mm Cu. STANDED P.V.C. INSULATED CONDUCTOR
6. 20% SPARE TERMINALS PROVIDED
7. REDUCTION GEAR RATIO 20 : 1 MAKE GRPS MATERIAL OF GEAR EN8 / STEEL
8. LUBRICATION OF GEARS : NON HARDENED GREASE FILLED GEAR BOX

**AUX. SWITCH CONTACT DETAILS FOR ISOLATOR(4NO/4NC)**

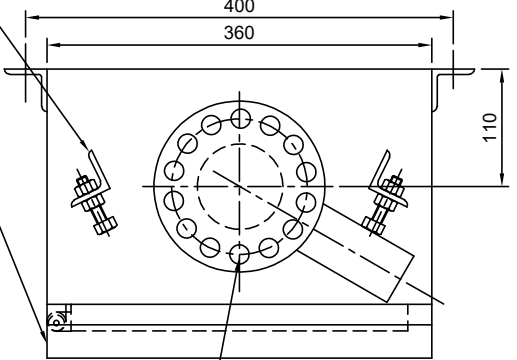
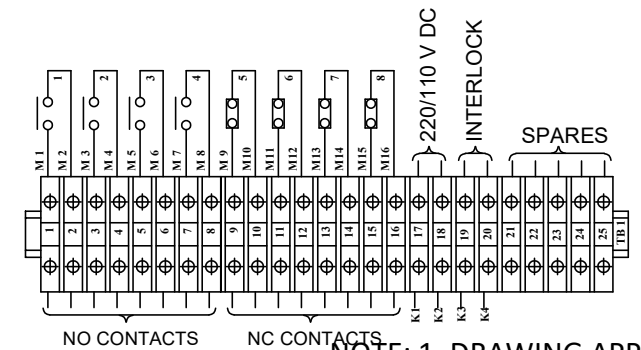

**SCHEMATIC DIAGRAM:**

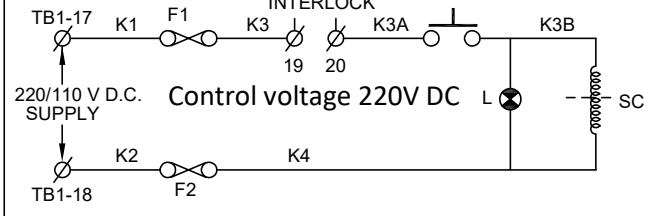

**NOTE: 1. DRAWING APPROVAL SUBJECT TO VALID TYPE TEST REPORTS, TO BE CHECKED DURING ACCEPTANCE TESTS**  
**2. FOR EPC CONTRACTS ONLY**

**LEGEND:**

- F1,F2 ----- FUSES (2 Amp Rating)
- PB ----- PUSH BUTTON
- L ----- INDICATION LAMP
- SC ----- SOLENOID COIL

Drawing approval subject to valid vendor registration

REVISIONS	TITLE:
D	MANUAL OPERATING MECHANISM (33 KV, 2000 A ISOLATOR)
C	
B	
A	

**Chief Engineer/Projects**  
**APTRANSCO/VS/Vijayawada.**

**GR POWER SWITCHGEAR LTD.,**  
**JEEDIMETLA HYDERABAD-500 055 INDIA**

SCALE:N.T.S	 21-03-2023
DATE	
DRAWN	
CHECKED	
APPROVED	 DRG.NO: 4. CN APT 03
REV	

NAME PLATE DETAILS FOR ISOLATOR

 MANUFACTURED & SUPPLIED BY <b>GR POWER SWITCHGEAR LTD.,</b> JEEDIMETLA, HYDERABAD - 500 055	
CUSTOMER :	M/s. TRANSMISSION CORPORATION OF AP LIMITED
PROJECT :	
CONTRACTOR :	
P.O. NO :	
TYPE :	HDB
SL. NO :	AS APPLICABLE
YEAR OF Mfg. :	
RATING : Un	33 KV ; In : 2000 A ; WEIGHT IN KG :
IMPLUSE(UI):	170 KV Peak; SWITCHING(Us): NA KV Peak;
P.F :	70 KV rms; STC(lth): 25 KA rms; DURATION: 3 Sec;
OPERATING MECHANISM :	MANUAL(RG)
CONTROL VOLTAGE :	220/110 VDC
Control voltage 220V DC 150	

NOTE: 1. DRAWING APPROVAL SUBJECT TO VALID TYPE TEST REPORTS, TO BE CHECKED DURING ACCEPTANCE TESTS  
2. FOR EPC CONTRACTS ONLY

Drawing approval subject to valid vendor registration





**Chief Engineer/Projects**  
**APTRANSCO/VS/Vijayawada.**

Project, contractor, PO, date ,year of MFG shall be stamped during inspection

1. Minimum 300mm plinth shall be maintained for CT/PT/CVT/ Isolators/IVT in the substation during foundation works to ensure Safe live to ground clearance as per IE rules.
2. since the supply of terminal connectors is not in the scope of Manufacturer as mentioned in the drawings. The EPC contractor Shall be instructed to supply the same in line with CT/PT/CVT/Isolator /IVTs requirement and compatibility.

**NOTES :**

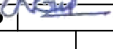
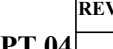
1. ENGRAVED LETTER SIZE : 3 mm
2. LETTER ETCHED WHITE ON BLACK BACKGROUND
3. MATERIAL : ALUMINIUM
4. THICKNESS : 1 mm

<table border="1"> <tr> <th colspan="4">REVISIONS</th> </tr> <tr> <th>D</th> <th>C</th> <th>B</th> <th>A</th> </tr> <tr> <td> </td> <td> </td> <td> </td> <td> </td> </tr> <tr> <td> </td> <td> </td> <td> </td> <td> </td> </tr> </table>	REVISIONS				D	C	B	A									TITLE: <b>NAME PLATE DETAILS</b> ( FOR 33 KV )	SCALE:N.T.S	
	REVISIONS																		
	D	C	B	A															
DATE	21-03-2023																		
DRAWN																			
CHECKED																			
APPROVED																			
DRG.NO:	4. CZ APT 04	REV																	
 <b>GR POWER SWITCHGEAR LTD.,</b> JEEDIMETLA HYDERABAD-500 055 INDIA																			

**SCHEDULE OF GUARANTEED TECHNICAL PARTICULARS FOR 33 KV, 2000A WITHOUT EARTH SWITCH**

S.No	DESCRIPTION		33 KV
1	Type/Installation	:	"DB" Double Break - OUTDOOR
2	Manufacturer's Name and country of manufacture	:	GR POWER SWITCHGEAR LTD.,
3	Standards according to which the isolators are manufactured.	:	IS 9921Part I to V & IEC 62271-102
4	Maximum design voltage at which the isolator can operate (kV).	:	36 KV
5	Frequency (Hz)	:	50 Hz
6	Rated voltage (kV)	:	33 KV
7	Maximum current that can be safely interrupted by the Isolator inductive (A & % PF) Capacitive (A & % PF)	:	0.7 Amps at 0.15 p.f.
8	Continuous current rating normal (Amps) under site conditions (Amps).	:	2000 Amps
9	Rated short time current		<u>MAIN SWITCH</u>
	i) For 3 Seconds (kA rms)	:	25 KA rms
	ii) For 1 Second (kA rms)	:	Not Applicable
	iii) Rated peak short time current (KV P)	:	62.5 KA rms
10	Current density at the minimum cross section of		
	a) Moving blade (Amps/Sq.mm)	:	2.0 Amps/Sq.mm for HDE Cu. Tube
	b) Terminal pad	:	1.0 Amp/Sq.mm for EC grade Alu. Flat.
	c) Contacts	:	1.6 Amps/Sq.mm for HDE Cu. Flat.
11	Maximum temperature rise of current carrying parts when carrying rated current continuously (Deg.C).	:	Within the specified limits of IS/IEC 62271-102
12	Insulation levels		
	i) Impulse withstand voltage (kV Peak) Phase to Earth Isolating Distance.	:	170/195 KV Peak
	ii) Switching surge withstand voltage (kV Peak) Phase to Earth isolating distance.	:	Not applicable

**Chief Engineer/Projects  
APTRANSCO/VIS/Vijavawada.**

S.No	DESCRIPTION		33 KV
	iii) Power Frequency withstand voltage (kV rms) Phase to Earth isolating distance.	:	70/80 KV rms
13	Minimum clearance in air		
	i) Between poles (mm)	:	1000 mm for a phase spacing of 1300 mm
	ii) Between live parts and earth (mm)	:	450 mm
	iii) Between live parts when switch is open.		
	a) On the same pole (mm)	:	715 mm
	b) Between adjacent poles (mm)	:	1050 mm
14	Rated mechanical terminal load		
	i) Load along the terminal connector side (Kg).	:	Not Applicable as per IS/IEC
	ii) Load across the terminal connector side (Kg).	:	Not Applicable as per IS/IEC
15	Torque required to operate the switch in Kg.m.	:	36 Kg m
16	Contact Zone		
	i) Horizontal deflection (mm)		
	ii) Vertical deflection (mm)	:	Not applicable
	iii) Total amplitude of longitudinal movement w.r.t conductor supporting fixed contact		
17	Design and construction		
	i) No. of insulators per pole	:	Three
	ii) No. of breaks per pole	:	Two
	iii) Type of closing / opening mechanism (Horizontal / vertical break straight etc.).	:	Horizontal break for Isolator
	iv. Contacts		
	a) Material and grade	:	Thickness of Silver plating : 15 Microns Minimum Hard Drawn Electrolytic Copper flat, silver plated  micron thickness.
	b) Cross-sectional area (Sq.mm)	:	1280 Sq.mm for 2000A

**Chief Engineer/Projects**  
**APTRANSCO/VS/Vijayawada.**

S.No	DESCRIPTION	33 KV
v	Moving blades	
	a) Material and grade	Thickness of Silver plating : 15 Microns Minimum : Hard Drawn Electrolytic Copper tube, silver plated of 15 micron thickness.
	b) Cross-sectional area (Sq.mm)	: 1055 Sq.mm for 2000A
vi)	Contact support	
	a) Material and size of channel / block.	: 8 mm Thick MS HDG
vii)	Rain hood-material grade and size	: MS HDG
viii)	Turn & Twist with Reduction Gear Type mechanism	
	a) Material and size of clamps	: 6 mm thick M.S. Flat - HDG
	b) Material size of springs	: S.S Sheet
	c) Whether springs are encased	: Not encased
ix)	Nuts and bolts	
	a) Size, material and grade in live parts.	} M8 and above are of MS HDG.
	b) Size, material and grade in other parts.	
x)	Insulator base plate material and size of plate below insulators.	} 6 mm thick M.S. Hot dip galvanised plate
xi)	Bearings	
	a) Material and size of housing	: MS HDG
	b) No. of bearings, location & size	: 1 No. below centre rotating post insulator
xii)	Tandem pipe	
	a) Size, length class and No. of pipes	: As per GA drawings
	b) Size of shackle screw	: Suitable for 25 NB
	c) No. of bearings / bush and its material and size.	: 6 Nos. bush bearings, brass, 16 mm ID Size.
xiii)	Type of interlock	: Not Applicable

**Chief Engineer/Projects**  
**APTRANSCO/VS/Vijayawada.**

S.No	DESCRIPTION		33 KV
xiv)	Down pipe size, length and class	:	40 mm NB Class B GI Pipe.
xv)	Type of universal/swivel joint		
	a) Between bearing & down pipe	:	Universal joint
	b) Between down pipe and operating mechanism.	:	Vernier Flange
xvi)	Operating mechanism		Manual operated mechanism for M.S
	a) Control cabinet		
	Material and thickness	:	3 Thick AL Sheet
	Degree of protection	:	IP : 55 as per IS 2147
	Type size and no. of cable glands.	:	Double compression type, 2 Nos. 19 mm. (Contractor scope of supply)
	Whether removable gland plate provided.	:	Yes, removable gland plate provided.
	b) Make type, rating and Qty. of Motors	:	Not Applicable
	Auxiliary blocks	:	4 NO / 4 NC contacts for Main Switch Mani 10 A, 2 A DC breaking with 2A - 1 No.
	Terminal blocks	:	UBT-4
	Insulated Wires	:	1100 V grades, 2.5 Sq.mm PVC
xvii)	Base		
	a) Size of steel sections used	:	100 x 50 mm
	b) Overall size	:	1060 x 100 x 50 mm x 5 mm
	c) Total weight	:	9 Kgs approx

for GR POWER SWITCHGEAR LTD.,



AUTHORIZED SIGNATORY

**Chief Engineer/Projects**  
**APTRANSCO/VS/Vijayawada.**