

NOTE: 1. DRAWING APPROVAL SUBJECT TO VALID TYPE TEST REPORTS, TO BE CHECKED DURING ACCEPTANCE TESTS
2. FOR EPC CONTRACTS ONLY

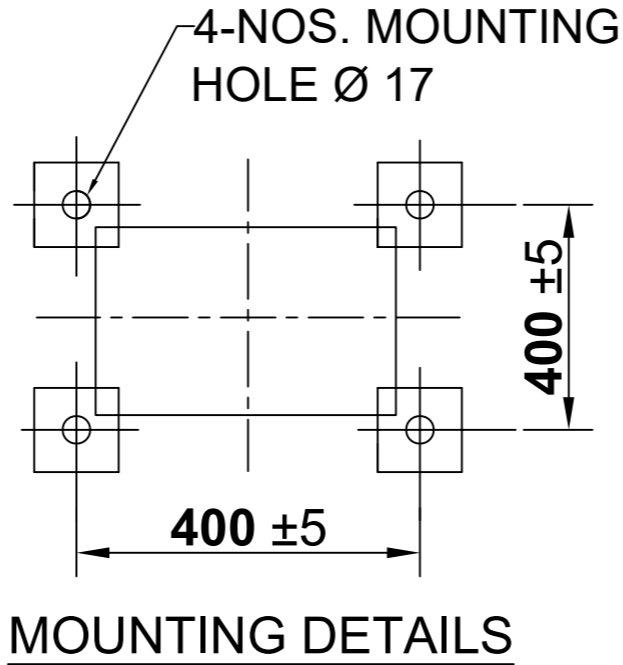
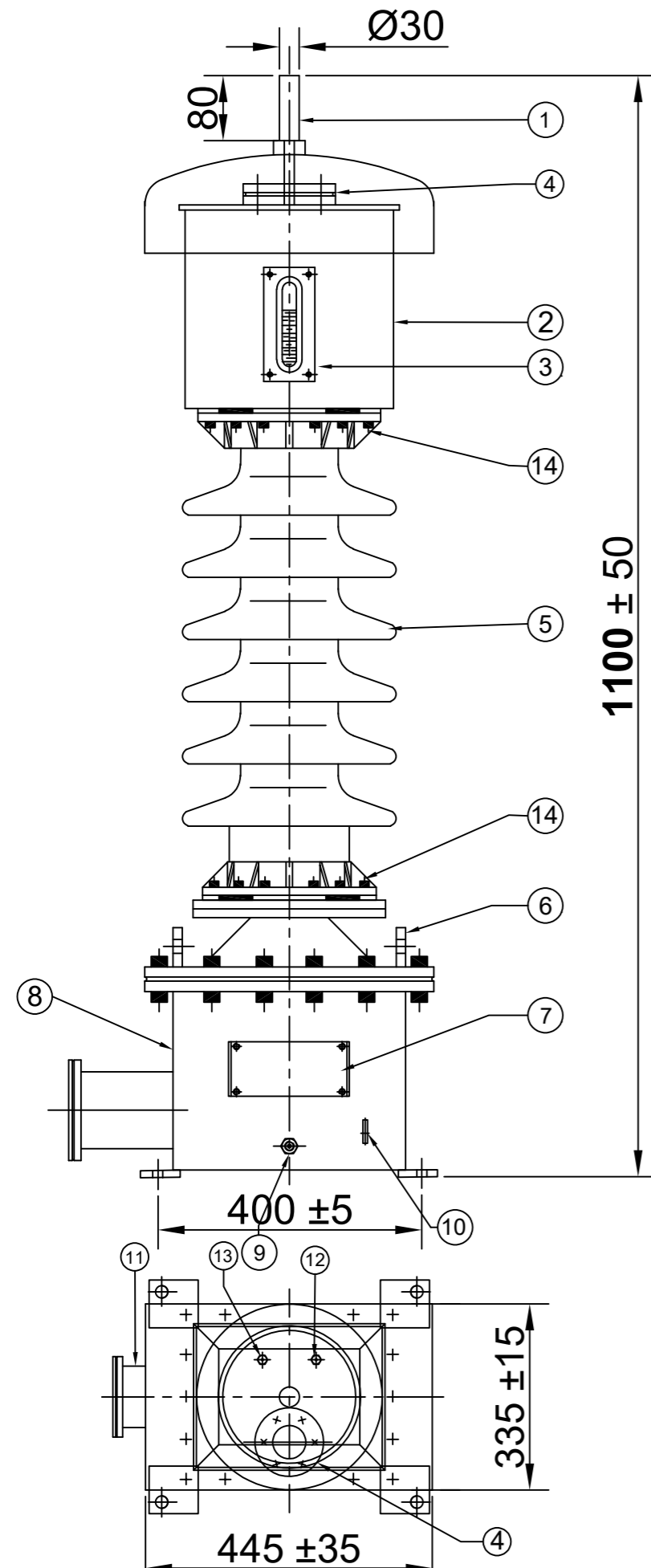

MOUNTING DETAILS

NOTES :

1. ALL FERROUS PARTS EXPOSED TO THE ATMOSPHERE SHALL BE PAINTED WITH P.U PAINT SHADE 631 OF IS: 5.
2. MAKE OF BUSHING: IEC/MODERN/BHEL/ABIL/CJI/GENESIS
3. TOTAL CREEPAGE DISTANCE :- 900 mm (Min.)
4. QUANTITY OF OIL :- 20 LITRES APPROX.
5. TOTAL WEIGHT OF PT : 130 KGS APPROX.
6. ALL HARDWARE SHALL BE HOT DIP GALVANIZED.
7. TRANSFORMER OIL AS PER IEC : 60296.
8. ALL GASKETS SHALL BE FIXED IN PROPERLY MACHINED GROOVES.
9. ALL GASKETS SHALL BE MADE OF NITRILE BUTYL RUBBER.

| S.No. | DESCRIPTION | QTY | MATL |
|-------|--------------------------------|-----|----------------------|
| 1 | H.T TERMINAL | 1 | COPPER NICKEL PLATED |
| 2 | OIL EXPANSION CHAMBER | 1 | M.S |
| 3 | OIL LEVEL INDICATOR | 1 | Al+Glass |
| 4 | PRESSURE RELEASE DEVICE | 1 | AL+Bakelite |
| 5 | BUSHING | 1 | PORCELAIN |
| 6 | LIFTING PLUG | 2 | M.S |
| 7 | NAME AND RATING PLATE | 1 | AL.Anodised |
| 8 | TANK WITH COVER | 1 | M.S |
| 9 | OIL DRAIN PLUG | 1 | M.S |
| 10 | EARTHING FLAT 80x50x8mm THICK. | 2 | M.S |
| 11 | SECONDARY TERMINAL BOX | 1 | M.S |
| 12 | NITROGEN VALVE | 1 | BRASS |
| 13 | OIL FILLING PLUG | 1 | M.S |
| 14 | BUSHING CLAMP (CEMENTED) | 2 | GI/CI |

**CHIEF ENGINEER
POWER SYSTEMS, PLANNING & DESIGN
APTRANSCO**

| | | |
|------|----------------------|----------------|
| | | |
| R0 | FOR APPROVAL | 06.01.2021 |
| REV. | REVISION DESCRIPTION | DATED INITIALS |

CLIENT : TRANSMISSION CORPORATION OF ANDHRA PRADESH LIMITED
PROJECT NAME : AS APPLICABLE

| UNLESS OTHERWISE SPECIFIED | | DATE | NAME | MATERIAL | <div style="border: 1px solid black; padding: 2px; display: inline-block;">MEHRU</div> MEHRU ELECTRICAL & MECHANICAL ENGINEERS (P) LTD. | |
|---|--|--------|------------|----------|--|----------|
| 1. ALL DIMENSIONS ARE IN mm. | | DGN. | 06.01.2021 | SPS | | AS ABOVE |
| 2. TOLERANCE WHEREVER NOT INDICATED ±5% | | DRN. | 06.01.2021 | AKASH | | |
| | | CHD. | 06.01.2021 | BLS | | |
| | | SCALE: | N.T.S | | DRG.NO ME-33PT-GA-02 | |
| TITLE : GENERAL ARRANGEMENT DRAWING FOR 33KV POTENTIAL TRANSFORMER | | | | | | |
| SHEET No. | | 1 OF 5 | | | | |

Drawing approval subject to valid vendor registration

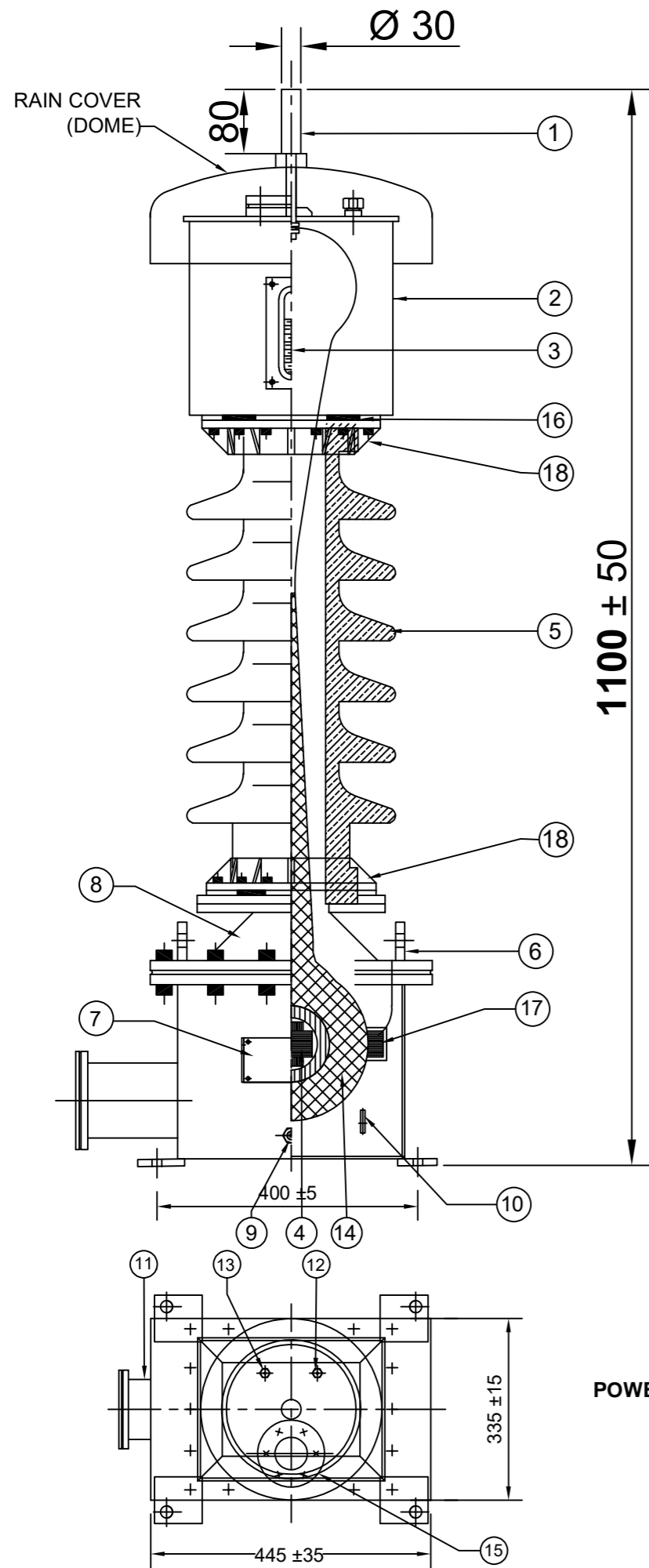

NOTE: 1. DRAWING APPROVAL SUBJECT TO VALID TYPE TEST REPORTS, TO BE CHECKED DURING ACCEPTANCE TESTS
2. FOR EPC CONTRACTS ONLY

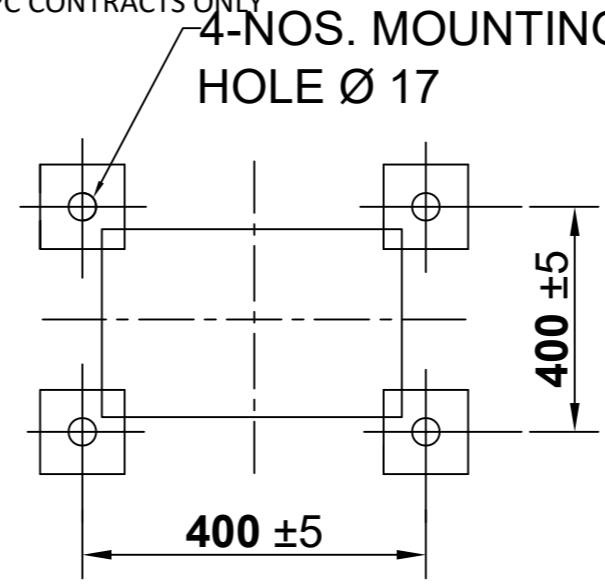

MOUNTING DETAILS

NOTES :

1. ALL FERROUS PARTS EXPOSED TO THE ATMOSPHERE SHALL BE PAINTED WITH P.U PAINT SHADE 631 OF IS: 5.
2. MAKE OF BUSHING: IEC/MODERN/BHEL/ABIL/CJI/GENESIS
3. TOTAL CREEPAGE DISTANCE :- 900 mm (Min.)
4. QUANTITY OF OIL :- 20 LITRES APPROX.
5. TOTAL WEIGHT OF PT : 130 KGS APPROX.
6. ALL HARDWARE SHALL BE HOT DIP GALVANIZED.
7. TRANSFORMER OIL AS PER IEC : 60296.
8. ALL GASKETS SHALL BE FIXED IN PROPERLY MACHINED GROOVES.
9. ALL GASKETS SHALL BE MADE OF NITRILE BUTYL RUBBER.

Drawing approval subject to valid vendor registration

| S.No. | DESCRIPTION | QTY | MATL |
|-------|--------------------------------|-----|----------------------|
| 1 | H.T TERMINAL | 1 | COPPER NICKEL PLATED |
| 2 | OIL EXPANSION CHAMBER | 1 | M.S |
| 3 | OIL LEVEL INDICATOR | 1 | AI+Glass |
| 4 | L.T COIL WITH PAPER INSULATION | 1 | CU./PAPER |
| 5 | BUSHING | 1 | PORCELAIN |
| 6 | LIFTING PLUG | 2 | M.S |
| 7 | NAME AND RATING PLATE | 1 | AL.Anodised |
| 8 | TANK WITH COVER | 1 | M.S |
| 9 | OIL DRAIN PLUG | 1 | M.S |
| 10 | EARTHING FLAT 80x50x8mm THICK. | 2 | M.S |
| 11 | SECONDARY TERMINAL BOX | 1 | M.S |
| 12 | NITROGEN VALVE | 1 | BRASS |
| 13 | OIL FILLING PLUG | 1 | M.S |
| 14 | H.T COIL WITH PAPER INSULATION | 1 | CU./PAPER |
| 15 | PRESSURE RELEASE DEVICE | 1 | ALU.+Bakelite |
| 16 | BUSHING GASKET | 2 | N.B.R |
| 17 | STACK LAMINATION | 1 | CRGO |
| 18 | BUSHING CLAMP (CEMENTED) | 2 | GI/CI |

**CHIEF ENGINEER
POWER SYSTEMS, PLANNING & DESIGN
APTRANSCO**

| | | |
|------|----------------------|----------------|
| REV. | REVISION DESCRIPTION | DATED INITIALS |
| R0 | FOR APPROVAL | 06.01.2021 |

| | | | | | |
|---|--------|------------|--|------------------------------|---|
| CLIENT : TRANSMISSION CORPORATION OF ANDHRA PRADESH LIMITED | | | | PROJECT NAME : AS APPLICABLE | |
| UNLESS OTHERWISE SPECIFIED 1. ALL DIMENSIONS ARE IN mm. 2. TOLERANCE WHEREVER NOT INDICATED ±5% | DGN. | 06.01.2021 | SPS | MATERIAL AS ABOVE | <div style="border: 1px solid black; padding: 2px; display: inline-block;">MEHRU</div> MEHRU ELECTRICAL & MECHANICAL ENGINEERS (P) LTD. |
| | DRN. | 06.01.2021 | AKASH | | |
| | CHD. | 06.01.2021 | BLS | | |
| | SCALE: | N.T.S | | | |
| TITLE : | | | SECTIONAL ARRANGEMENT DRAWING FOR 33KV POTENTIAL TRANSFORMER | | |
| SHEET No. | | | 2 OF 5 | | |
| DRG.NO | | | ME-33PT-SE-02 | | |

MEHRU VOLTAGE TRANSFORMER

| | | | |
|------------------------|--------------------|---------------------|--------------------|
| SR.No. | | REF.STD. | IS: 16227 |
| TYPE | Outdoor Oil Cooled | RATIO | 33 kV / $\sqrt{3}$ |
| Highest System Voltage | 36 kV | | 110V/ $\sqrt{3}$ |
| PHASE | Single | BURDEN | 10 VA |
| Insulation level | 70/170 kV | CLASS | 0.2 |
| Thermal Burden | 10 VA | Simultaneous Burden | 10 VA |
| Frequency | 50 Hz | Type | Earthed |
| Voltage Factor | 1.2 | TIME CONT. & | 1.5 |
| | | TIME FOR | 30 Sec |
| | | YEAR OF MFG. | 2021 |

TOTAL WEIGHT OF VT : 130 KGS APPROX.
 QUANTITY OF OIL :- 20 LITRES APPROX. TOTAL CREEPAGE DISTANCE :- 900 mm (Min.)

MADE IN INDIA BY
MEHRU ELECTRICAL AND MECHANICAL ENGINEERS (P) LTD.
 E-1247 RIICO INDUSTRIAL AREA , PHASE I , EXT GHATAL , BHIWADI-301 019

SUITABLE FOR HOT LINE WASHING CONNECTION DIAGRAM

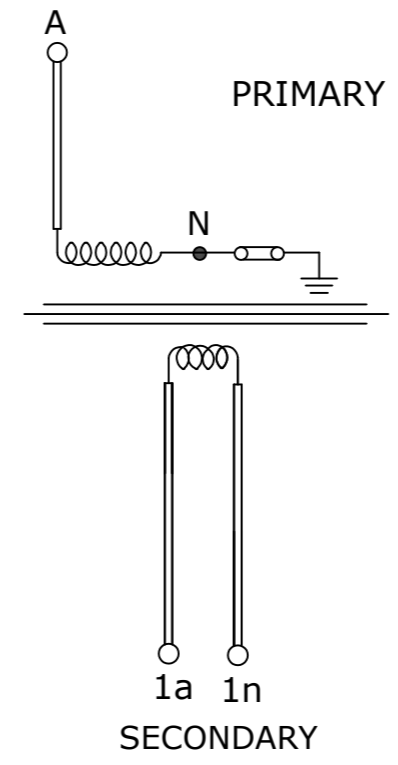

CAUTION :
 1. DO NOT REMOVE EARTH LINK WHEN IN OPERATION.

Drawing approval subject to valid vendor registration

115 ±10

195 ±15

NOTES:-

1. THICKNESS OF RATING PLATE 1.2 mm
2. MATERIAL OF NAME PLATE SHALL BE AL. ANODIZED.
3. SERIAL NUMBER SHALL BE ENGRAVING BEFORE THE DISPATCH.

- NOTE: 1. DRAWING APPROVAL SUBJECT TO VALID TYPE TEST REPORTS, TO BE CHECKED DURING ACCEPTANCE TESTS
 2. FOR EPC CONTRACTS ONLY

CHIEF ENGINEER
POWER SYSTEMS, PLANNING & DESIGN
APTRANSCO

| | | |
|------|----------------------|----------------|
| RO | FOR APPROVAL | 06.01.2021 |
| REV. | REVISION DESCRIPTION | DATED INITIALS |

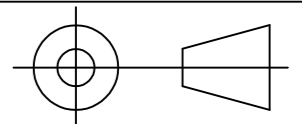
| | | | |
|---|--------|------------|--|
| CLIENT : TRANSMISSION CORPORATION OF ANDHRA PRADESH LIMITED PROJECT NAME : AS APPLICABLE | | | |
| UNLESS OTHERWISE SPECIFIED 1. ALL DIMENSIONS ARE IN mm. 2. TOLERANCE WHEREVER NOT INDICATED ±5% | DGN. | 06.01.2021 | SPS |
| | DRN. | 06.01.2021 | AKASH |
| | CHD. | 06.01.2021 | BLS |
| | SCALE: | N.T.S | |
| TITLE : | | |  MEHRU ELECTRICAL & MECHANICAL ENGINEERS (P) LTD. |
| NAME PLATE DRAWING FOR 33KV POTENTIAL TRANSFORMER | | | |
| SHEET No. 3 OF 5 | | |  DRG.NO ME-33PT-NP-02 |

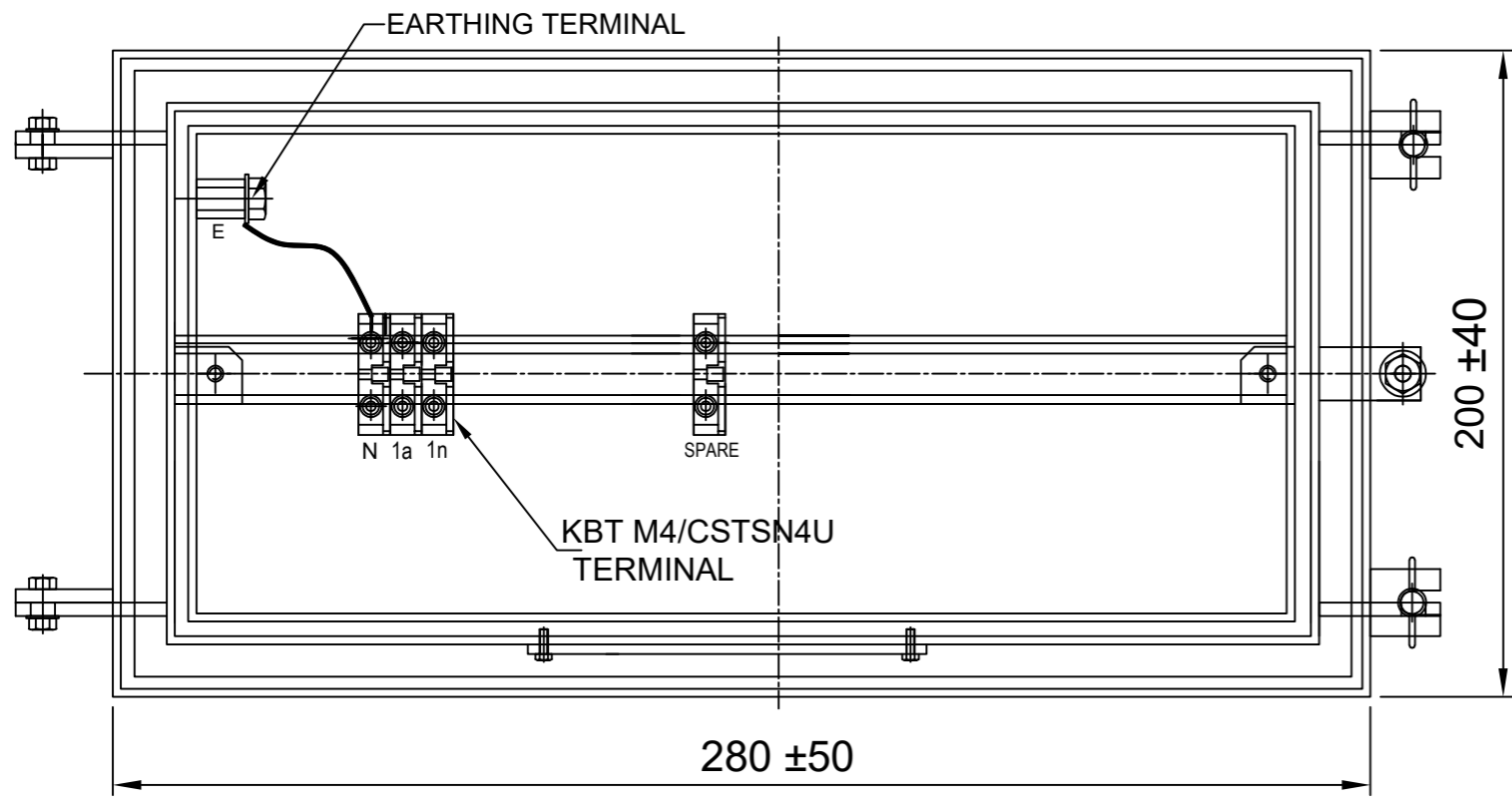

WINDING 1

'N' : NEUTRAL TERMINAL
'E' : EARTHING TERMINAL

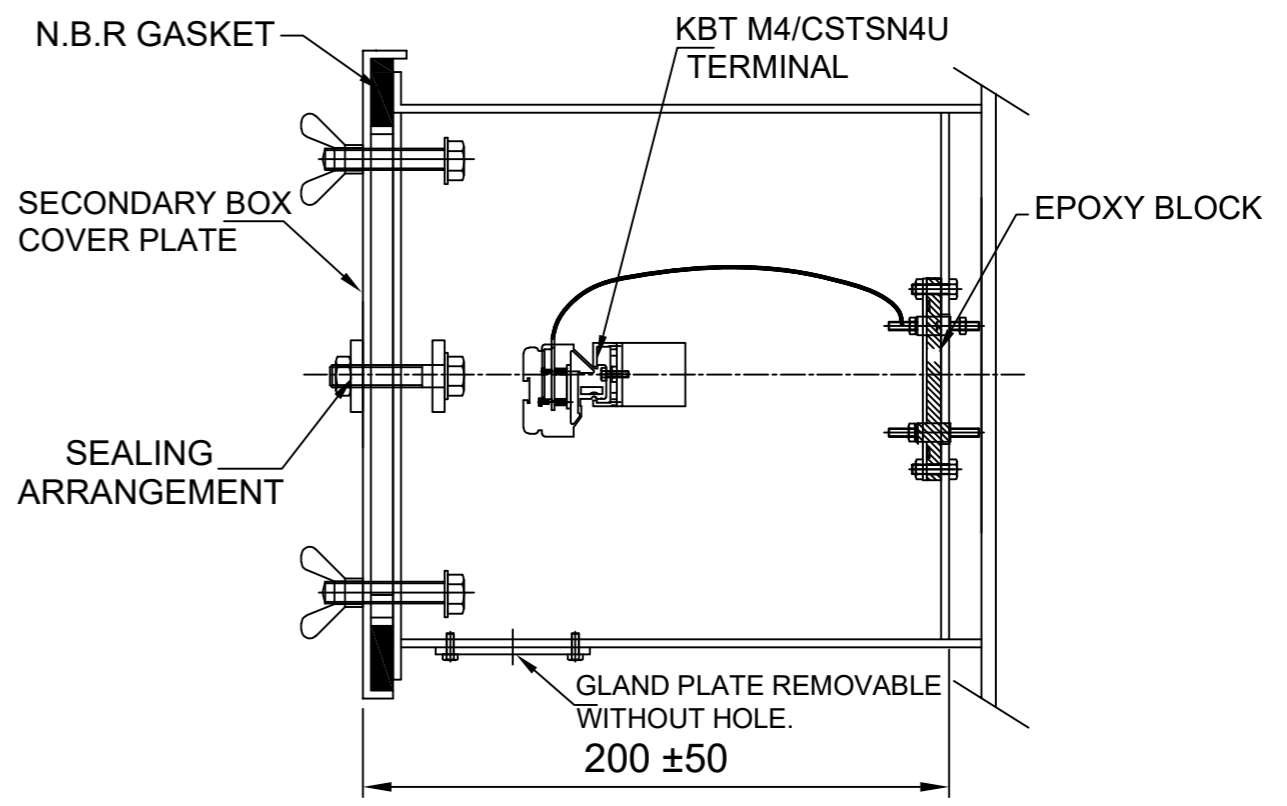

SIDE VIEW

NOTES:-

1. SECONDARY TERMINAL BOX SHALL BE PROVIDED REMOVABLE GLAND PLATE WITHOUT HOLE.
2. SECONDARY TERMINAL BOX SHALL BE PROVIDED WITH COVER.
3. M.S SHEET THICKNESS FOR TERMINAL BOX 3.0mm. & FOR COVER 2.0mm.
4. MATERIAL OF GASKET: NITRILE BUTYL RUBBER GASKET.
5. DEGREE OF PROTECTION : IP 55
6. 20% SPARE TERMINAL SHALL BE PROVIDED.

- NOTE: 1. DRAWING APPROVAL SUBJECT TO VALID TYPE TEST REPORTS, TO BE CHECKED DURING ACCEPTANCE TESTS
2. FOR EPC CONTRACTS ONLY

Drawing approval subject to valid vendor registration

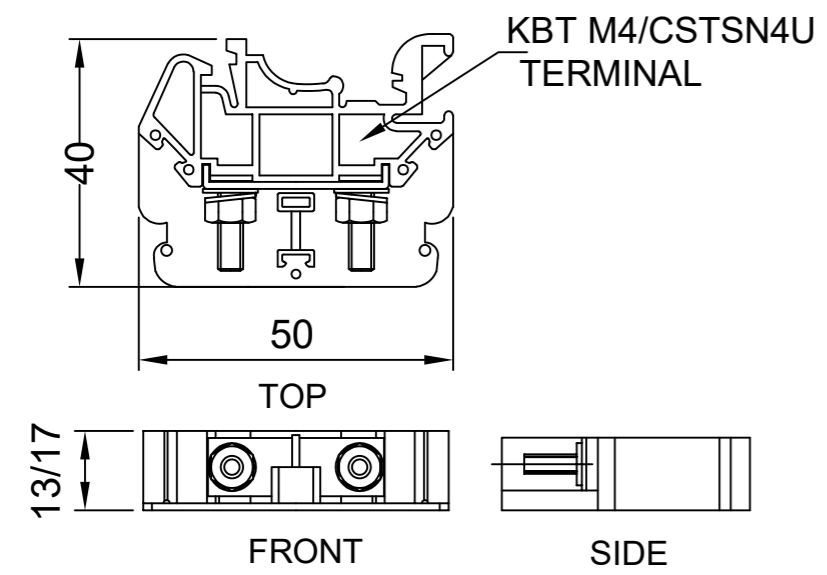

MATERIAL: POLYAMIDE
MAKE: ELMEX/CONNECTWELL

TERMINAL (DETAIL)

**CHIEF ENGINEER
POWER SYSTEMS, PLANNING & DESIGN
APTRANSCO**

| | | |
|------|----------------------|----------------|
| REV. | REVISION DESCRIPTION | DATED INITIALS |
| R0 | FOR APPROVAL | 06.01.2021 |

| | | | | | | |
|---|-------|------------|------------------|------------------------------|--|-------|
| CLIENT : TRANSMISSION CORPORATION OF ANDHRA PRADESH LIMITED | | | | PROJECT NAME : AS APPLICABLE | | |
| UNLESS OTHERWISE SPECIFIED 1. ALL DIMENSIONS ARE IN mm. 2. TOLERANCE WHEREVER NOT INDICATED ±5% | DATE | NAME | MATERIAL | MEHRU | MEHRU ELECTRICAL & MECHANICAL ENGINEERS (P) LTD. | |
| | DGN. | 06.01.2021 | | | | SPS |
| | DRN. | 06.01.2021 | | | | AKASH |
| | CHD. | 06.01.2021 | | | | BLS |
| SCALE: | N.T.S | | M.S | DRG.NO ME-33PT-STB-02 | | |
| TITLE : | | | | | | |
| SECONDARY TERMINAL BOX DRAWING FOR 33KV POTENTIAL TRANSFORMER | | | SHEET No. 4 OF 5 | | | |

| GUARANTEE TECHNICAL PARTICULARS OF 33kV POTENTIAL TRANSFORMER | | |
|--|--|--|
| S.NO | DESCRIPTION | 33kV |
| 1 | Type | Mehru Electrical & Mechanical Engineers (P) Ltd, Bhiwadi, (Raj), Inida |
| 2 | Manufacturer's type designation | Outdoor, Oil Cooled, Electromagnetic Type, Voltage Transformer |
| 3 | Mounting of tank (bottom) | Bottom |
| 4 | System rated voltage/highest voltage (kv) | 33/36 |
| 5 | Rated primary voltage (kv) | 33kV/ $\sqrt{3}$ |
| 6 | Secondary winding details | |
| | (a)No.ofsecondary windings | 1 |
| | (b)Rated secondary voltage(V) | 110 V/ $\sqrt{3}$ |
| | ©Rated burden VA (simultaneous) | 10VA |
| | (d)Class of accuracy | Wdg:1: - 0.2 |
| 7 | Maximum ratio error with % rated burden and 5 % normal primary voltage | In limits as per IS 16227 |

NOTE: 1. DRAWING APPROVAL SUBJECT TO VALID TYPE TEST

4714155/2021/EEMRT-ENE51

REPORTS, TO BE CHECKED DURING ACCEPTANCE TESTS

2. FOR EPC CONTRACTS ONLY

Drawing approval subject to valid vendor registration

| | | |
|----|--|-------------------------------------|
| 8 | Maximum phase angle error with % rated burden and 5 % normal primary voltage | In limits as per IS 16227 |
| 9 | Temperature rise at 1.1 times rated voltage with rated burden deg.C | 50deg C |
| 10 | Rated voltage factor and time | 1.2 continuous & 1.5 for 30 seconds |
| 11 | Temperature rise for item-10 above deg.C | 50deg C |
| 12 | Impulse withstand test voltage (kv) peak | 170 |
| 13 | One minute power frequency withstand test voltage on secondary (kv rms) | 3 |
| 14 | One minute power frequency withstand test voltage on primary (kv rms) | 70 |
| 15 | Total creepage distance of the bushing mm | 25 mm/kV i.e. 900 mm |
| 16 | Grade of oil | EHV IS 335/IEC 60296 |
| 17 | Quantity of insulating oil (Litres) | 20Ltr Approx |
| 18 | Weight of oil (kg) | 16kgs Approx. |
| 19 | Total weight including oil (kg) | 130kG Approx |
| 20 | Whether sealed (if so type of sealing) | PRD |
| 21 | Over all dimensions | |
| | Height (mm) | 1100±50mm |

| | | |
|----|----------------------------|----------------------------------|
| | Length (mm) | 400±5mm |
| | Breadth (mm) | 400±5mm |
| | b) Partial discharge level | <10 pC at Um & <5 pc at 1.2Um/√3 |
| 22 | Weight of Steel | 35 kgs (Approx.) |
| | Weight of copper | 6 kgs (Approx.) |

**CHIEF ENGINEER
POWER SYSTEMS, PLANNING & DESIGN
APTRANSCO**

Drawing approval subject to valid vendor registration