

For EPC Contracts Only

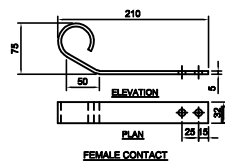
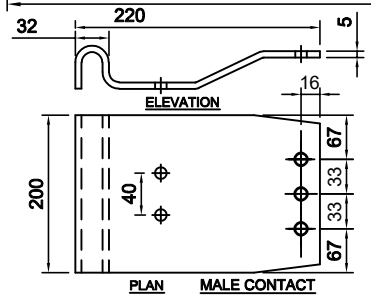
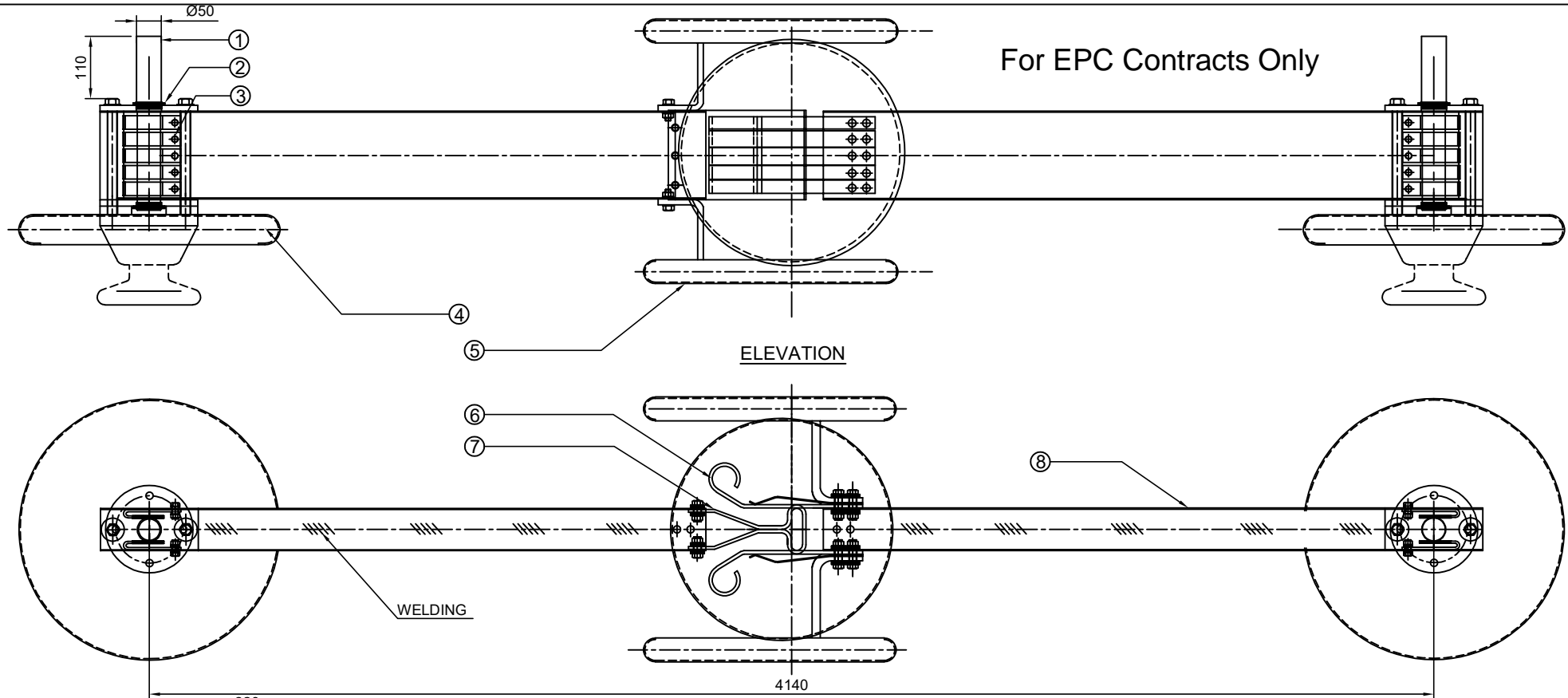

NOTE : DRAWING APPROVAL SUBJECT TO VALID TYPE TEST REPORTS.
 TO BE CHECKED DURING ACCEPTANCE TESTS.

Drawing approval subject to valid vendor registration

PART LIST :

1. TERMINAL CONTACT (50 OD Cu. ROD)	06 Nos.
2. BUSH (NYLON)	12 Nos.
3. TERMINAL CONTACT (5 PAIRS 32 x 6.2 HDECu FLAT)	60 Nos.
4. CORONA SHIELD ON INSULATORS (ALUMINUM)	06 Nos.
5. CORONA SHIELD ON CONTACTS (ALUMINUM)	12 Nos.
6. FEMALE CONTACT FINGER (32 x 6.2 mm Cu. FLAT, 5 PAIRS SILVER PLATED)	30 Nos.
7. MALE CONTACT (200 x 5 Cu. FLAT, 2 Nos. SILVER PLATED)	06 Nos.
8. CONTACT ARM (180 x 95 x 6 mm THICK ALUMINUM FORMED RECTANGULAR BOX)	06 Nos.

BOQ/SET

NOTE :

- ALL DIMENSIONS ARE IN MILLIMETERS
- ALL NON FERROUS CONTACT POINTS ARE SILVER PLTED (25 MICRONS) REMAINING CONTACT AREA TIN PLATED
- ALL FERROUS PARTS ARE HOT DIP GALVANIZED (610 grm /Sqm, 85 MICRONS)
- THE INDICATED DIMENSIONS ARE SUBJECTED TO THE MANUFACTURING TOLERANCES :
 UPTO 50 mm ----- ±3%
 101 TO 300 mm ----- ±1%
 51 TO 100 mm ----- ±2%
 ABOVE 300 mm ----- ±0.5%
- FABRICATED 'C' CHANNEL OF 180 X 47.5 X 6 THK ALU - 2 Nos.

REVISIONS			
D	C	B	A

Chief Engineer
 Projects

CLIENT : M/s. TRANSMISSION CORPORATION OF ANDHRA PRADESH LIMITED

TITLE:
**MAIN CONTACT ASSEMBLY
 (420 kV, 3150A)**

SCALE:N.T.S	
DATE	27 - 02 - 2024
DRAWN	
CHECKED	
APPROVED	



**GR POWER SWITCHGEAR LTD.,
 JEEDIMETLA HYDERABAD-500 055 INDIA**

DRG.NO:	REV
4. HSM 4250 02	

For EPC Contracts Only

FIXED CONTACT ASSEMBLY :

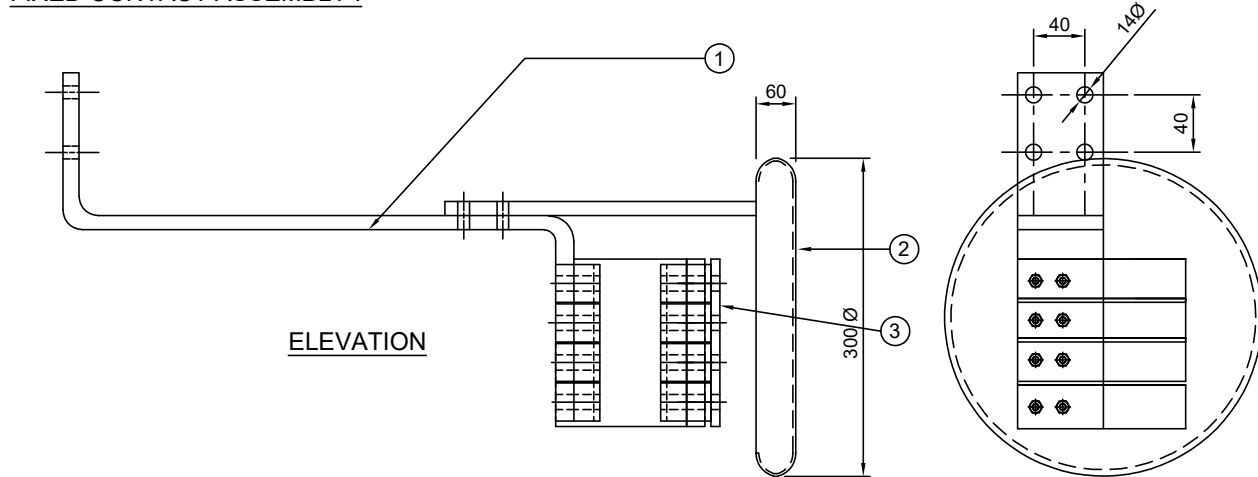

ELEVATION

END VIEW

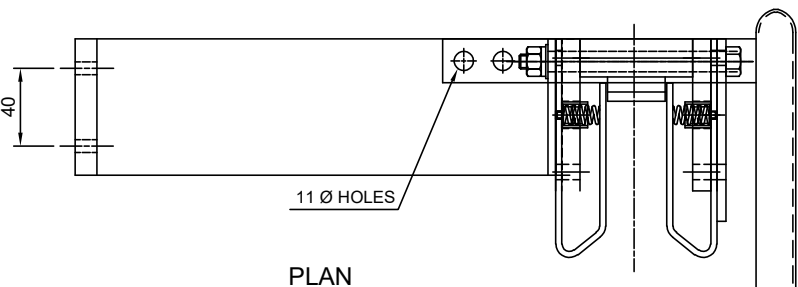

PLAN

MOVING CONTACT ASSEMBLY :

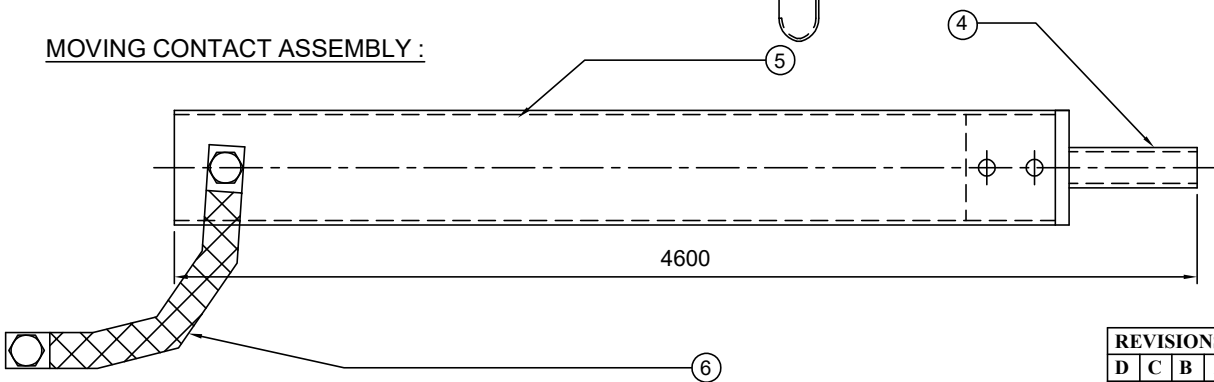

PART LIST

1. CONTACT HOLDER (100 x 12 Alu. FLAT)
2. CORONA SHIELD (Ø300 Alu. 1 No.)
3. CONTACT FINGER (25 x 4 Cu. FLAT 4 PAIRS, SILVER PLATED)
4. MOVING CONTACT(40 OD 29 ID Cu. PIPE SILVER PLATED)
5. CONTACT ARM ((101 OD x 3 Thk Alu. TUBE)
6. FLEXIBLE (25 x 3 mm Cu. BRAIDED FLEXIBLE 5 Nos.)

NOTES :

1. ALL DIMENSIONS ARE IN MILLIMETERS
 2. ALL COPPER CONTACT POINTS ARE SILVER PLATED (25 MICRONS) REMAINING AREA TIN PLATED
 3. ALL FERROUS PARTS ARE HOT DIP GALVANIZED (610 grm /Sqm, 85 MICRONS)
 4. THE INDICATED DIMENSIONS ARE SUBJECT TO THE MANUFACTURING TOLERANCES :
- | | | | |
|---------------|-----------|--------------|-------------|
| UPTO 50 mm | ----- ±3% | 51 TO 100 mm | ----- ±2% |
| 101 TO 300 mm | ----- ±1% | ABOVE 300 mm | ----- ±0.5% |

NOTE : DRAWING APPROVAL SUBJECT TO VALID TYPE TEST REPORTS.
TO BE CHECKED DURING ACCEPTANCE TESTS.

Drawing approval subject to valid vendor registration

Chief Engineer
Projects

REVISIONS			
D	C	B	A

CLIENT : M/s. TRANSMISSION CORPORATION OF ANDHRA PRADESH LIMITED		SCALE:N.T.S	
TITLE: EARTH SWITCH CONTACT ASSEMBLY (FOR 420 kV, 31 mm/kV)		DATE	27 - 02 - 2024
GR POWER SWITCHGEAR LTD., JEEDIMETLA HYDERABAD-500 055 INDIA		DRAWN	<i>[Signature]</i>
		CHECKED	<i>[Signature]</i>
		APPROVED	<i>[Signature]</i>
DRG.NO:		REV	
4. HSE 4250 03			

For EPC Contracts Only

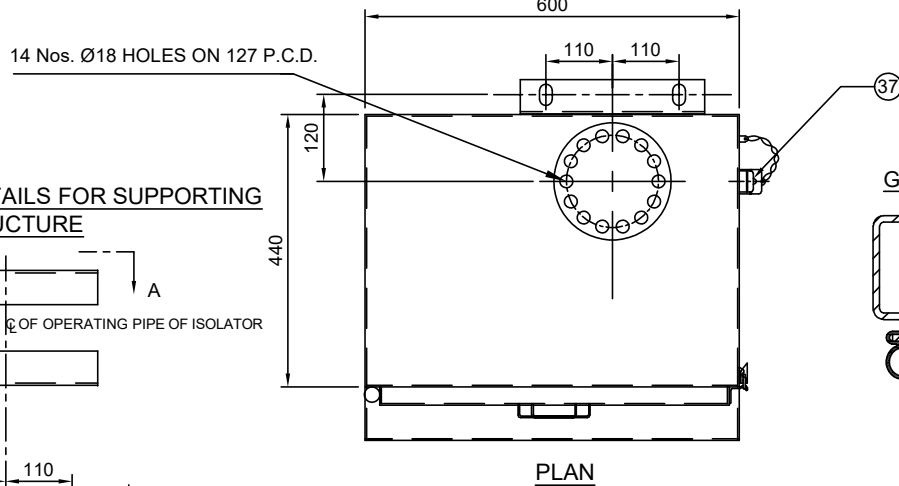
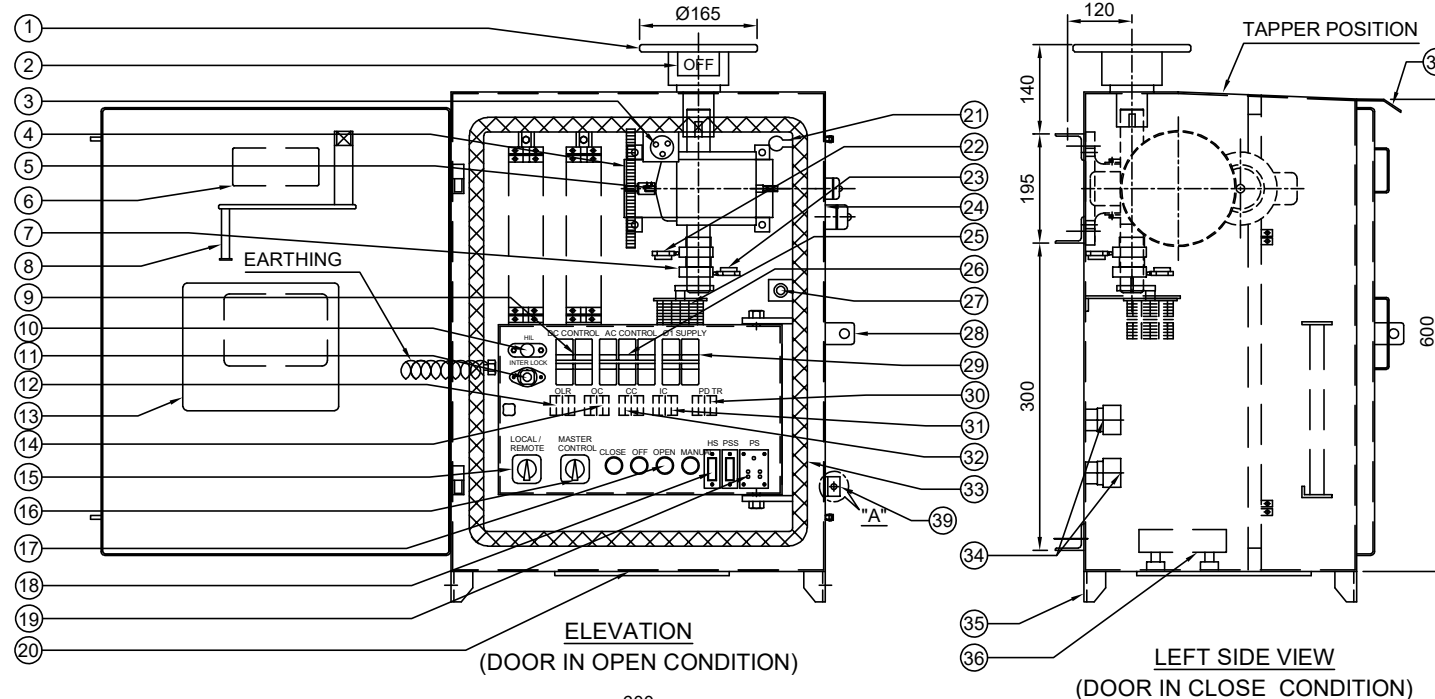

FIXING DETAILS FOR SUPPORTING STRUCTURE

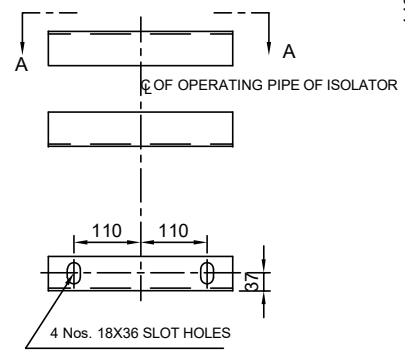

VIEW AT 'A - A'

GASKET DETAILS

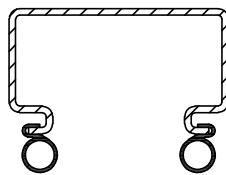

DETAIL "A"

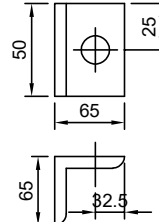

PART LIST:

1. OUTPUT FLANGE (10 mm THICK, 14 HOLES)
2. ON/OFF INDICATOR
3. THERMOSTAT (30 TO 85°C RECOMMENDED SETTING 40°)
4. GEAR BOX (SPUR / WORM & WORM SHAFT, RATIO 1 : 630)
5. MOTOR (Ø3, 415 Volts, 0.5 HP MOTOR)
6. CAUTION NAME PLATE
7. LIMIT SWITCH OPERATING CAM
8. OPERATING HANDLE
9. DC CONTROL SWITCH (2 POLE MCB)
10. PUSH CAP (FOR HIL)
11. HANDLE INTERLOCK (HIL)
12. OVER LOAD RELAY CUM SPP (OLR)
13. SCHEMATIC DIAGRAM
14. OPENING CONTACTOR (OC)
15. LOCAL/REMOTE SELECTOR SWITCH(S3, CAM TYPE)
16. MASTER CONTROL SWITCH (S4, CAM TYPE)
17. OPEN / CLOSE / MANUAL / OFF PUSH BUTTON (PBO / PBC / PBH / EPB)
18. HEATER / POWER SOCKET SWITCHES (HS, PSS)
19. POWER SOCKET (PS)
20. DETACHABLE CABLE GLANDS FIXING PLATE (WITH GLANDS)
21. CUBICLE LAMP HOLDER (SUITABLE FOR " CFL " LAMP)
22. LIMIT SWICH (LSO)
23. LIMIT SWITCH (LSC)
24. CUBICLE WITH DOOR (3 mm THICK AL. SHEET)
25. AUX. SWITCH (12 NO / 12 NC)
26. AC CONTROL SWITCH (3 POLE MCB)
27. DOOR OPERATED LIGHT SWITCH (LS)
28. PROVISION FOR PAD LOCK
29. Ø1 AC SUPPLY SWITCH (2 POLE MCB)
30. POLE DISCREPANCY TIMER (PD TR)
31. INTERLOCK CONTACTOR (IC)
32. CLOSING CONTACTOR (CC)
33. RUBBER GASKET (EPDM)
34. TERMINAL BLOCK (STUD TYPE OF ELMEX OR ITS EQUIVALENT)
35. SUPPORT CLEATS (AL WELDED TO BOX)
36. HEATER, 80 WATTS, 240 V (LOCATED AWAY FROM THE CABLE ENTRY)
37. MANUAL OPERATING CAP / COVER
38. RAIN SHADE
39. EARTHING TERMINAL (2 Nos. 65 x 65 x 5 Alu. ANGLE (WELDING TO BOX) WITH 1/2" x 2" BOLT WITH CHECK NUT AND WASHERS)

NOTE :

1. ALL DIMENSIONS ARE IN MILLIMETERS
2. CUBICLE WILL BE NATURAL FINISH FOR INSIDE AND OUTSIDE.
3. DEGREE OF PROTECTION IP : 55 AS PER IS/IEC : 60529
4. 20% SPARE TERMINALS WILL BE PROVIDED
5. WIRING WILL BE DONE WITH 1100 V. GRADE
 - a) FOR POWER CIRCUIT (AC SUPPLY) : 2.5 Sq.MM Cu. STRANDED
 - b) FOR AUXILIARY CIRCUIT (DC SUPPLY) : 2.5 Sq.MM Cu. STRANDED P.V.C. INSULATED CONDUCTOR
6. WEIGHT OF THE BOX : 100 Kg (Approx.)

CLIENT : M/s. TRANSMISSION CORPORATION OF ANDHRA PRADESH LIMITED

REVISIONS			
D	C	B	A

TITLE:
MOTOR OPERATING MECHANISM FOR ISOLATOR (MASTER DRIVE FOR 420 kV)

SCALE:N.T.S	
DATE	27 - 02 - 2024
DRAWN	
CHECKED	
APPROVED	
DRG.NO:	4. HMS 4250 04
REV	



GR POWER SWITCHGEAR LTD.,
JEEDIMETLA HYDERABAD-500 055 INDIA

Chief Engineer
Projects

Drawing approval subject to valid vendor registration

For EPC Contracts Only

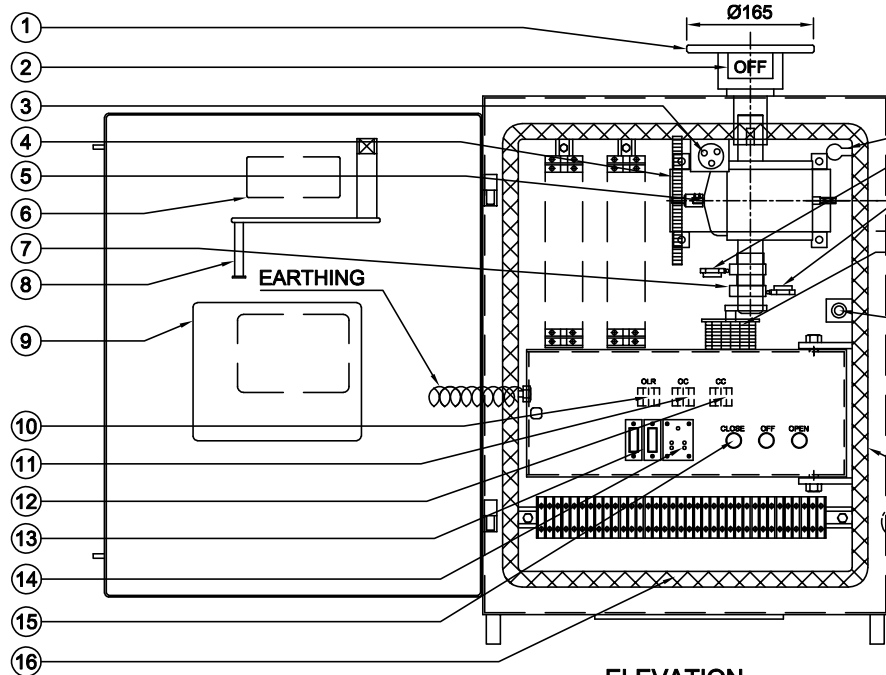

ELEVATION
(DOOR IN OPEN CONDITION)

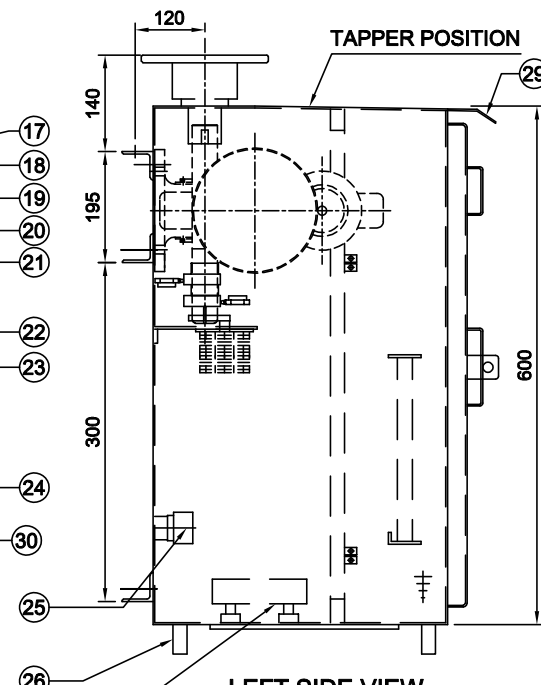

LEFT SIDE VIEW
(DOOR IN CLOSE CONDITION)

PART LIST:

1. OUTPUT FLANGE (10 mm THICK, 14 HOLES)
2. ON/OFF INDICATOR
3. THERMOSTAT (30 TO 85°C RECOMMENDED SETTING 40°)
4. GEAR BOX (SPUR / WORM & WORM SHAFT, RATIO 1 : 630)
5. MOTOR (Ø3, 415 Volts, 0.5 HP MOTOR)
6. CAUTION NAME PLATE
7. LIMIT SWITCH OPERATING CAM
8. OPERATING HANDLE FIXED TO DOOR
9. SCHEMATIC DIAGRAM PLATE
10. OVER LOAD RELAY CUM SPP (OLR),
11. OPENING CONTACTOR (OC)
12. CLOSING CONTACTOR (CC)
13. HEATER / POWER SOCKET SWITCHES (HS, PSS)
14. POWER SOCKET (PS)
15. OPEN / CLOSE / MANUAL / OFF PUSH BUTTON (PBO / PBC / PBH / EPB)
16. DETACHABLE CABLE GLANDS FIXING PLATE (WITH OUT GLANDS)
17. CUBICLE LAMP HOLDER
18. LIMIT SWITCH (LSO)
19. LIMIT SWITCH (LSC)
20. CUBICLE WITH DOOR (3 mm THICK ALU. SHEET)
21. AUX. SWITCH (12 NO / 12 NC)
22. DOOR OPERATED LIGHT SWITCH (LS)
23. PROVISION FOR PAD LOCK
24. RUBBER GASKET (EPDM)
25. TERMINAL BLOCK (STUD TYPE OF ELMEX OR ITS EQUIVALENT)
26. SUPPORT CLEATS (M.S. WELDED TO BOX)
27. HEATER, 80 WATTS, 240 V WITH THERMOSTAT
28. MANUAL OPERATING CAP / COVER
29. RAIN SHADE
30. EARTHING TERMINAL (2 Nos. 65 x 65 x 5 Alu. ANGLE (WELDING TO BOX) WITH 1/2" x 2" BOLT WITH CHECK NUT AND WASHERS)

NOTE :

1. ALL DIMENSIONS ARE IN MILLIMETERS
2. CUBICLE WILL BE NATURAL FINISH FOR OUTSIDE AND INSIDE
3. DEGREE OF PROTECTION IP : 55 AS PER IS/IEC : 60529
4. 20% SPARE TERMINALS WILL BE PROVIDED
5. WIRING WILL BE DONE WITH 1100 V. GRADE
 - a) FOR POWER CIRCUIT (AC SUPPLY) : 2.5 Sq.MM Cu. STRANDED
 - b) FOR AUXILIARY CIRCUIT (DC SUPPLY) : 2.5 Sq.MM Cu. STRANDED P.V.C. INSULATED CONDUCTOR
6. WEIGHT OF THE BOX : 80 Kg (Approx.)

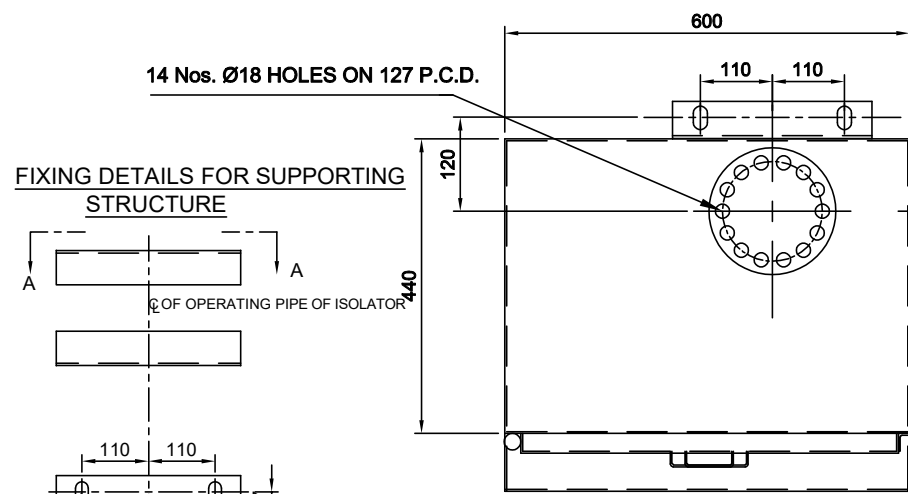

PLAN

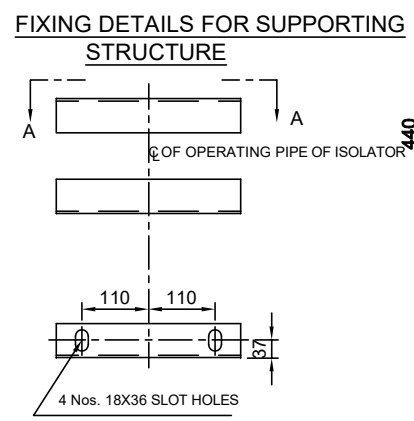

VIEW AT 'A - A'

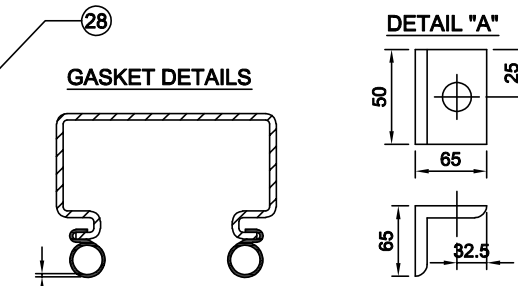

DETAIL "A"

Drawing approval subject to valid vendor registration

Chief Engineer
Projects

REVISIONS				CLIENT : M/s. TRANSMISSION CORPORATION OF ANDHRA PRADESH LIMITED	
D	C	B	A	TITLE:	
				MOTOR OPERATING MECHANISM FOR ISOLATOR (FOLLOWER DRIVE FOR 420 kV)	
				SCALE:N.T.S	
				DATE	27 - 02 - 2024
				DRAWN	
				CHECKED	
				APPROVED	
				DRG.NO:	4. HMS 4250 05
				REV	



GR POWER SWITCHGEAR LTD.,
JEEDIMETLA HYDERABAD-500 055 INDIA

For EPC Contracts Only

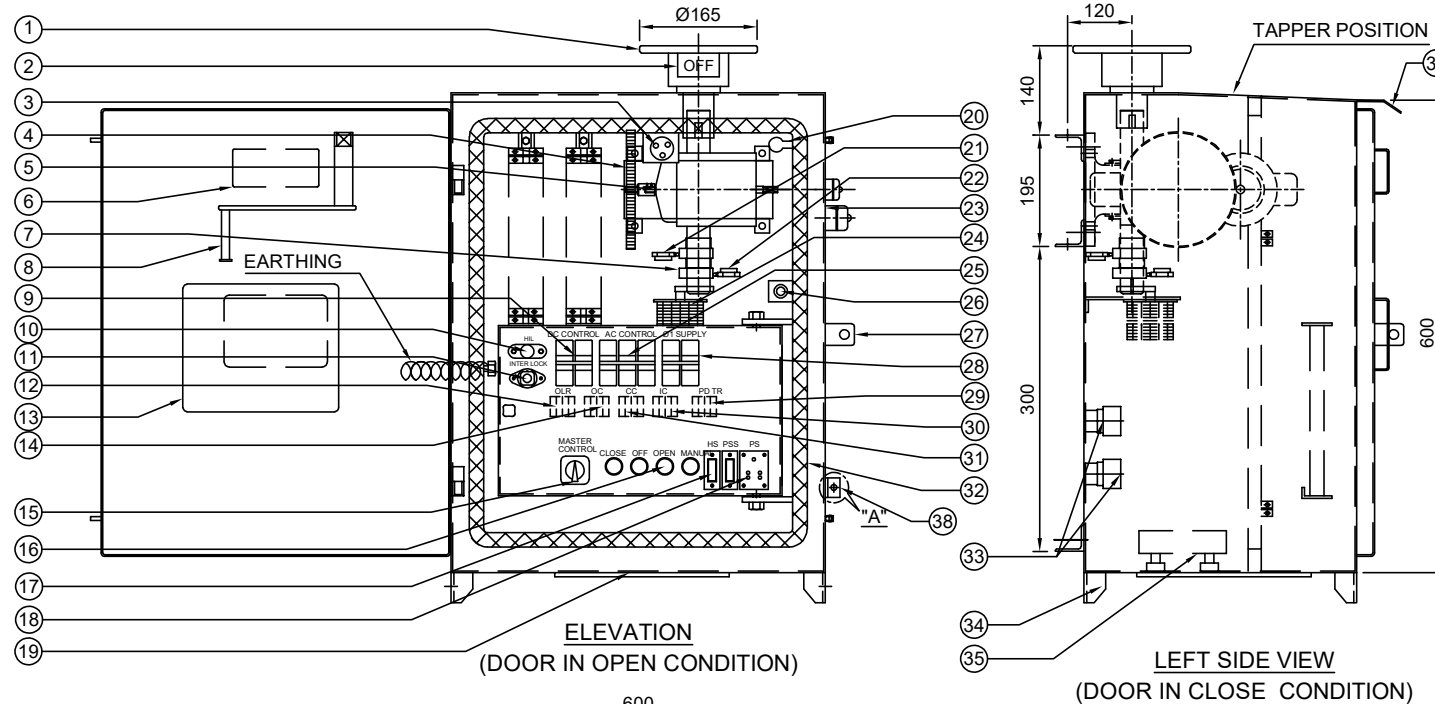

- PART LIST:**
1. OUTPUT FLANGE (10 mm THICK, 14 HOLES)
 2. ON/OFF INDICATOR
 3. THERMOSTAT (30 TO 85°C RECOMMENDED SETTING 40°)
 4. GEAR BOX (SPUR / WORM & WORM SHAFT, RATIO 1 : 630)
 5. MOTOR (Ø3, 415 Volts, 0.5 HP MOTOR)
 6. CAUTION NAME PLATE
 7. LIMIT SWITCH OPERATING CAM
 8. OPERATING HANDLE
 9. DC CONTROL SWITCH (2 POLE MCB)
 10. PUSH CAP (FOR HIL)
 11. HANDLE INTERLOCK (HIL)
 12. OVER LOAD RELAY CUM SPP (OLR)
 13. SCHEMATIC DIAGRAM
 14. OPENING CONTACTOR (OC)
 15. MASTER CONTROL SWITCH (S4, CAM TYPE)
 16. OPEN / CLOSE / MANUAL / OFF PUSH BUTTON (PBO / PBC / PBH / EPB)
 17. HEATER / POWER SOCKET SWITCHES (HS, PSS)
 18. POWER SOCKET (PS)
 19. DETACHABLE CABLE GLANDS FIXING PLATE (WITH GLANDS)
 20. CUBICLE LAMP HOLDER (SUITABLE FOR " CFL " LAMP)
 21. LIMIT SWITCH (LSO)
 22. LIMIT SWITCH (LSC)
 23. CUBICLE WITH DOOR (3 mm THICK AL. SHEET)
 24. AUX. SWITCH (6 NO / 6 NC)
 25. AC CONTROL SWITCH (3 POLE MCB)
 26. DOOR OPERATED LIGHT SWITCH (LS)
 27. PROVISION FOR PAD LOCK
 28. Ø1 AC SUPPLY SWITCH (2 POLE MCB)
 29. POLE DISCREPANCY TIMER (PD TR)
 30. INTERLOCK CONTACTOR (IC)
 31. CLOSING CONTACTOR (CC)
 32. RUBBER GASKET (EPDM)
 33. TERMINAL BLOCK (STUD TYPE OF ELMEX OR ITS EQUIVALENT)
 34. SUPPORT CLEATS (AL WELDED TO BOX)
 35. HEATER, 80 WATTS, 240 V (LOCATED AWAY FROM THE CABLE ENTRY)
 36. MANUAL OPERATING CAP / COVER
 37. RAIN SHADE
 38. EARTHING TERMINAL (2 Nos. 65 x 65 x 5 Alu. ANGLE (WELDING TO BOX) WITH 1/2" x 2" BOLT WITH CHECK NUT AND WASHERS)

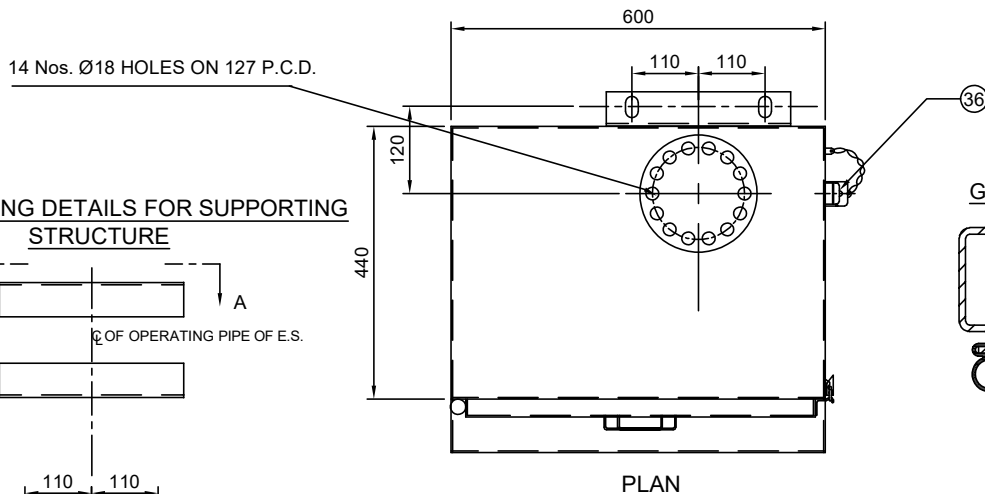

- NOTE :**
1. ALL DIMENSIONS ARE IN MILLIMETERS
 2. CUBICLE WILL BE NATURAL FINISH FOR OUTSIDE AND INSIDE.
 3. DEGREE OF PROTECTION IP : 55 AS PER IS/IEC : 60529
 4. 20% SPARE TERMINALS WILL BE PROVIDED
 5. WIRING WILL BE DONE WITH 1100 V. GRADE
 - a) FOR POWER CIRCUIT (AC SUPPLY) : 2.5 Sq.MM Cu. STRANDED
 - b) FOR AUXILIARY CIRCUIT (DC SUPPLY) : 2.5 Sq.MM Cu. STRANDED P.V.C. INSULATED CONDUCTOR
 6. WEIGHT OF THE BOX : 100 Kg (Approx.)

Drawing approval subject to valid vendor registration

CLIENT : M/s. TRANSMISSION CORPORATION OF ANDHRA PRADESH LIMITED

REVISIONS			
D	C	B	A

TITLE:
MOTOR OPERATING MECHANISM FOR E.S (MASTER DRIVE FOR 420 kV)

GR POWER SWITCHGEAR LTD.,
JEEDIMETLA HYDERABAD-500 055 INDIA

SCALE:N.T.S	
DATE	27 - 02 - 2024
DRAWN	
CHECKED	
APPROVED	
DRG.NO:	4. HME 4250 07
REV	

Chief Engineer
Projects

For EPC Contracts Only

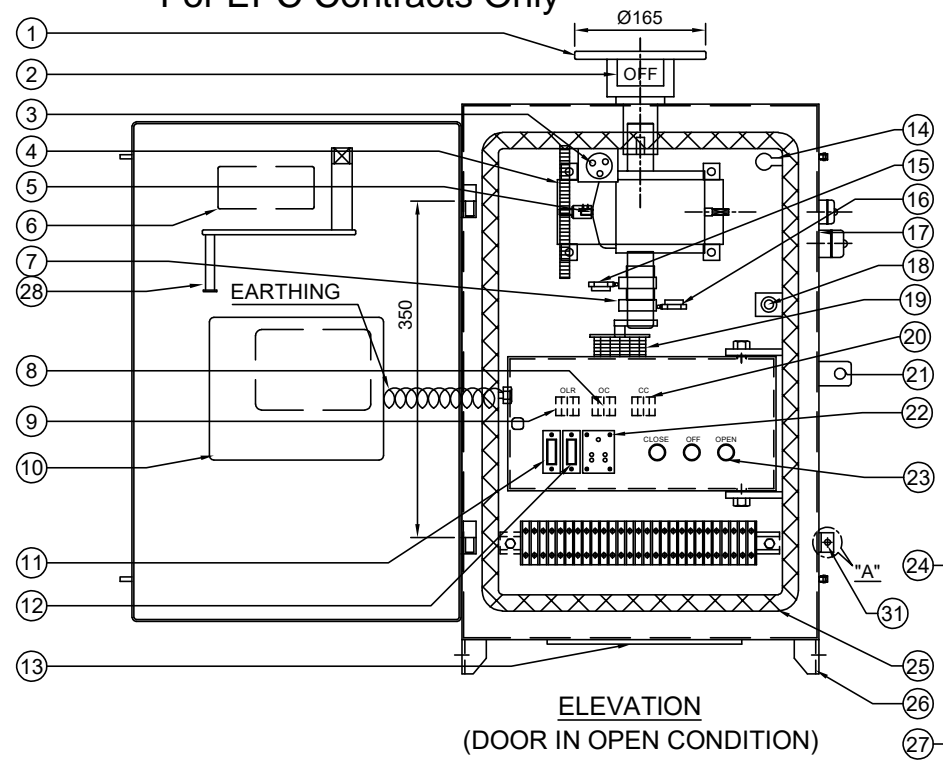

ELEVATION
(DOOR IN OPEN CONDITION)

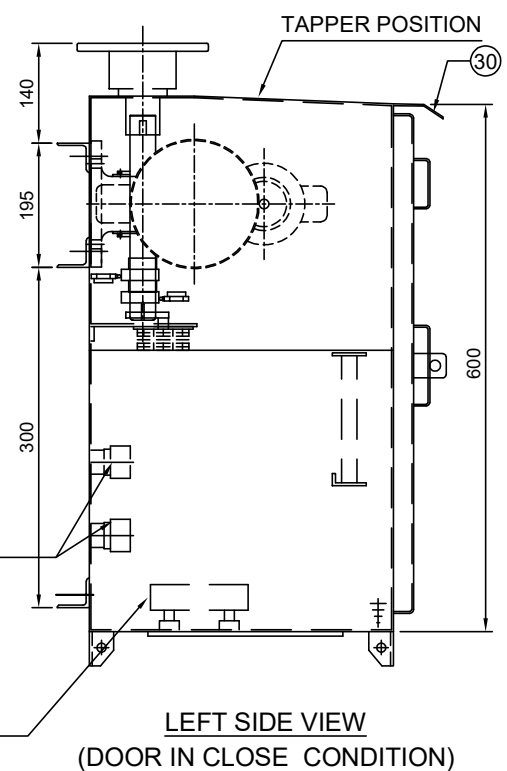

LEFT SIDE VIEW
(DOOR IN CLOSE CONDITION)

PART LIST:

1. OUTPUT FLANGE (10 mm THICK, 14 HOLES)
2. ON/OFF INDICATOR
3. GEAR BOX (SPUR / WORM & WORM SHAFT, RATIO 1 : 630)
4. THERMOSTAT (30 TO 85°C RECOMMENDED SETTING 40°)
5. MOTOR (Ø3, 415 Volts, 0.5 HP MOTOR)
6. CAUTION NAME PLATE
7. LIMIT SWITCH OPERATING CAM
8. OPENING CONTACTOR (OC)
9. OVER LOAD RELAY CUM SPP (OLR)
10. SCHEMATIC DIAGRAM
11. HEATER SWITCH (HS)
12. POWER SOCKET SWITCH (PSS)
13. DETACHABLE CABLE GLANDS FIXING PLATE (WITH GLANDS)
14. CUBICLE LAMP HOLDER (SUITABLE FOR " CFL " LAMP)
15. LIMIT SWITCH (LSO)
16. LIMIT SWITCH (LSC)
17. CUBICLE WITH DOOR (3 mm THICK ALU. SHEET)
18. DOOR OPERATED LIGHT SWITCH (LS)
19. AUX. SWITCH (6 NO + 6 NC)
20. CLOSING CONTACTOR (CC)
21. PROVISION FOR PAD LOCK
22. POWER SOCKET (PSS)
23. OPEN / CLOSE / OFF PUSH BUTTON (PBO / PBC / EPB)
24. TERMINAL BLOCK (STUD TYPE OF ELMEX OR ITS EQUIVALENT)
25. RUBBER GASKET (EPDM)
26. SUPPORT CLEATS (Alu. WELDED TO BOX)
27. HEATER, 80 WATTS, 240 V (LOCATED AWAY FROM THE CABLE ENTRY)
28. OPERATING HANDLE
29. MANUAL OPERATING CAP / COVER
30. RAIN SHADE
31. EARTHING TERMINAL (2 Nos. 65 x 65 x 5 ALU. ANGLE (WELDING TO BOX) WITH 1/2" x 2" BOLT WITH CHECK NUT AND WASHERS)

NOTE :

1. ALL DIMENSIONS ARE IN MILLIMETERS
2. CUBICLE WILL BE NATURAL FINISH FOR OUTSIDE AND INSIDE.
3. DEGREE OF PROTECTION IP : 55 AS PER IS/IEC : 60529
4. 20% SPARE TERMINALS WILL BE PROVIDED
5. WIRING WILL BE DONE WITH 1100 V. GRADE
 - a) FOR POWER CIRCUIT (AC SUPPLY) : 2.5 Sq.MM Cu. STRANDED
 - b) FOR AUXILIARY CIRCUIT (DC SUPPLY) : 2.5 Sq.MM Cu. STRANDED P.V.C. INSULATED CONDUCTOR
6. WEIGHT OF THE BOX : 80 Kg (Approx.)

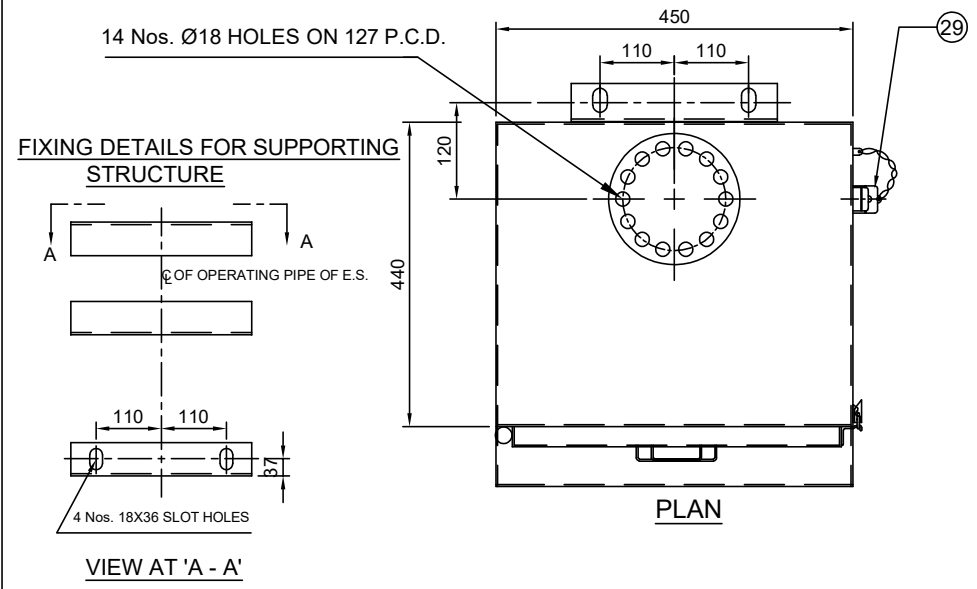

PLAN

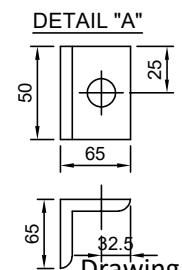
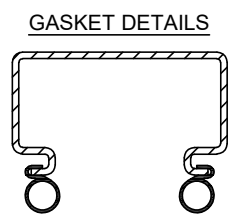

Drawing approval subject to valid vendor registration

Chief Engineer
Projects

REVISIONS			
D	C	B	A

CLIENT : M/s. TRANSMISSION CORPORATION OF ANDHRA PRADESH LIMITED		SCALE: N.T.S.	
TITLE: MOTOR OPERATING MECHANISM FOR E.S (FOLLOWER DRIVE FOR 420 kV)		DATE	27 - 02 - 2024
GR POWER SWITCHGEAR LTD., JEEDIMETLA HYDERABAD-500 055 INDIA		DRAWN	
		CHECKED	
		APPROVED	
DRG.NO:		REV	
4. HME 4250 08			

NOTE : DRAWING APPROVAL SUBJECT TO VALID TYPE TEST REPORTS.

TO BE CHECKED DURING ACCEPTANCE TESTS.

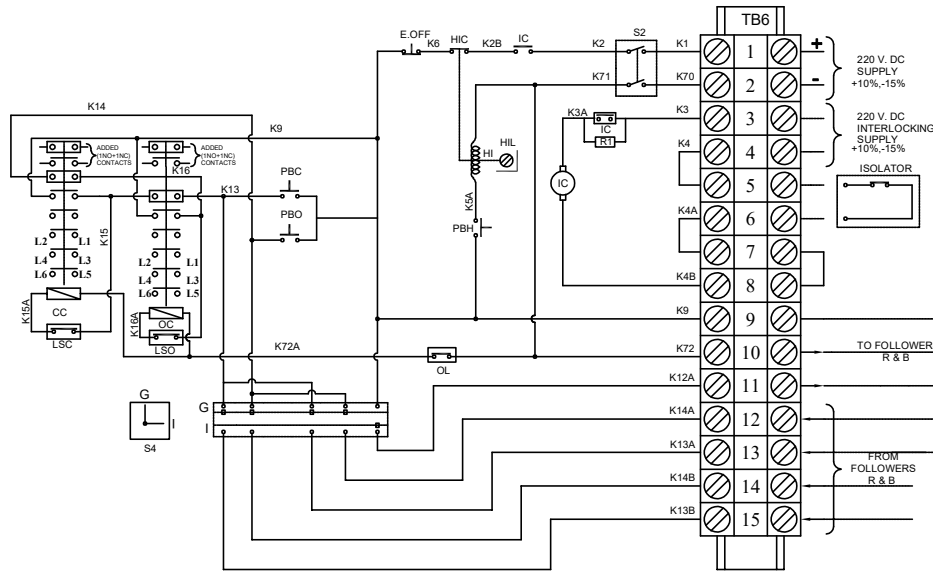

D.C. CONTROL CIRCUIT (Y POLE)

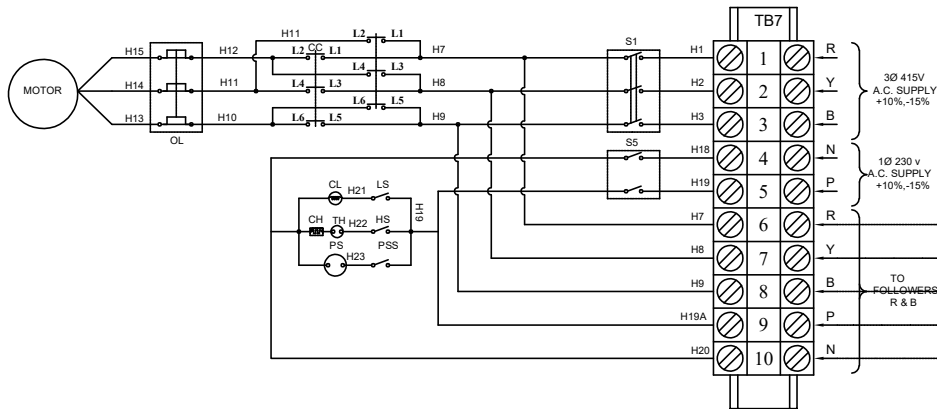

A.C. CONTROL CIRCUIT (Y POLE)

For EPC Contracts Only

FOR FOLLOWER DRIVES

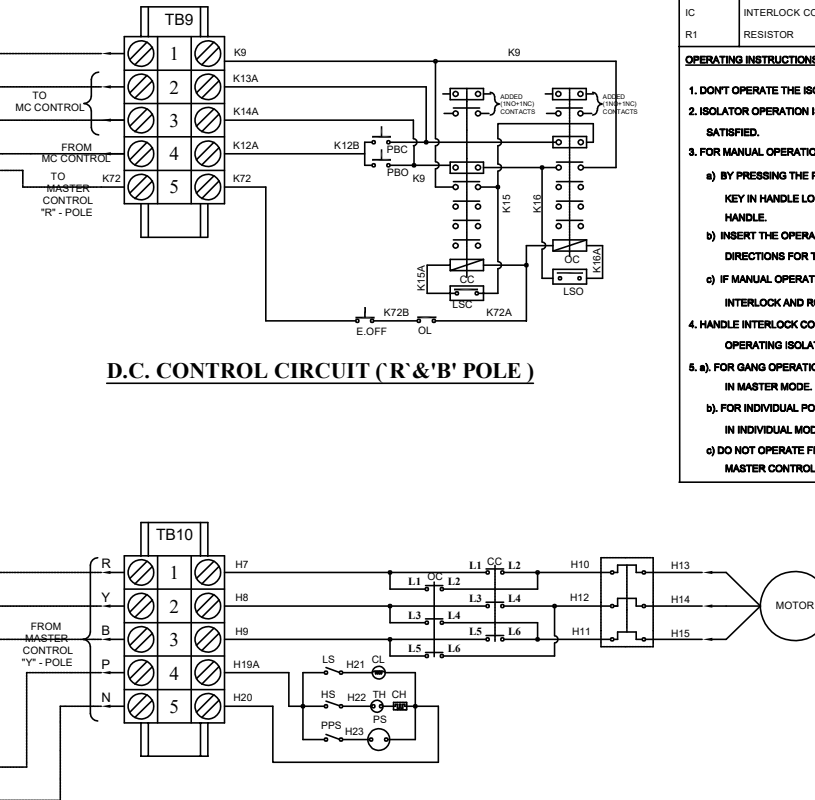

D.C. CONTROL CIRCUIT (R & B POLE)

A.C. CONTROL CIRCUIT (R & B POLES)

Drawing approval subject to valid vendor registration

LEGEND	DESCRIPTION	MAKE
HIC	HANDLE INTERLOCK CONTACT	SWITRON
M	MOTOR 3Ø 415 V, 0.5 HP	REMI / ELCEAN / CGL/HEMAL/HINDUSTAN
CH	CUBICLE HEATER 80 WATTS	RK ELECT./RAMANA ELECT.
S1	A.C. SUPPLY CONTROL SWITCH, 16 A MCB	C&S/EATON/HPL
S2	D.C. SUPPLY CONTROL SWITCH, 10 A MCB	C&S/EATON/HPL
S3	LOCAL/REMOTE SELECTOR SWITCH 10 A	SWITRON
S4	MASTER CONTROL SWITCH 16 A(MCB)	SWITRON
S5	Ø1 A.C. SUPPLY SWITCH (MCB) 10 A	C&S/EATON/HPL
OC,CC	OPEN/CLOSE CONTACTORS, 9 A	C&S/HPL
OL	OVER LOAD RELAY WITH SPP 1.0 TO 1.6 A	C&S/HPL
PBO,PBC	OPEN/CLOSE PUSH BUTTONS, 4 A	TEKNIQ/JAI BALAJI
LSO,LSC	OPEN/CLOSE LIMIT SWITCHES, 6 A	JAI BALAJI/MANI
PBH	MANUAL HANDLE PUSH BUTTONS, 4 A	TEKNIQ/JAI BALAJI
EPB	EMERGENCY PUSH BUTTON, 4 A	TEKNIQ/JAI BALAJI
HI	HANDLE INTERLOCK COIL, 20 WATTS	GRPSL
HIL	MANUAL HANDLE KEY INTERLOCK	RAMANA/PS POWER/EE
LS,SS,HS	LIGHT SOCKET, HEATER SWITCHES, 5A	MARU OR ITS EQUIVALENT
CL	CUBICLE LAMP HOLDER	MARU OR ITS EQUIVALENT
PS	POWER SOCKET, 5A	MARU OR ITS EQUIVALENT
TB	TERMINAL BLOCKS (UBT-4)	ELMEX/CONNECT WELL
TH	THERMOSTAT	BESL
PDTR	POLE DISCREPANCY TIMER (0.05 TO 30 SEC)	C&S
IC	INTERLOCK CONTACTOR 220 V, DC 7W (3 NO + 3 NC)	C&S/HPL
R1	RESISTOR	

OPERATING INSTRUCTIONS:

- DON'T OPERATE THE ISOLATOR WHEN THE 'CIRCUIT BREAKER' IS IN 'ON'
- ISOLATOR OPERATION IS POSSIBLE ONLY WHEN THE INTERLOCK CONDITIONS ARE SATISFIED.
- FOR MANUAL OPERATION FOLLOW THE FOLLOWING INSTRUCTIONS:-
 - BY PRESSING THE PUSH BUTTON (PBH) REMOVE THE CASTLE KEY AND KEEP THE KEY IN HANDLE LOCK AND ROTATE FOR GETTING WAY TO INSERT THE OPERATING HANDLE.
 - INSERT THE OPERATING HANDLE AND ROTATE IN CLOCK / ANTI CLOCK WISE DIRECTIONS FOR TO OPEN / CLOSE THE ISOLATOR RESPECTIVELY.
 - IF MANUAL OPERATION IS NOT NEEDED RESTORE THE CASTLE KEY IN THE HANDLE INTERLOCK AND ROTATE.
- HANDLE INTERLOCK CONTACT (HIC) FOR PREVENTING ELECTRICAL CLOSING WHILE OPERATING ISOLATOR THROUGH HANDLE
- FOR GANG OPERATION ENSURE THAT THE MASTER CONTROL SWITCH "MC" (S4) IS IN MASTER MODE. REMOTE / LOCAL GANG OPERATION IS POSSIBLE IN THE MODE
 - FOR INDIVIDUAL POLE ELECTRICAL OPERATION SET MASTER CONTROL SWITCH IN INDIVIDUAL MODE.
 - DO NOT OPERATE FROM REMOTE / LOCAL FOR GANG OPERATION WHEN THE MASTER CONTROL SWITCH IS IN INDIVIDUAL MODE.

Chief Engineer
Projects

REVISIONS				CLIENT : M/s. TRANSMISSION CORPORATION OF ANDHRA PRADESH LIMITED	
D	C	B	A	TITLE: SCHEMATIC DIAGRAM FOR MASTER & FOLLOWER DRIVE FOR E/S. OF 420 kV	
				SCALE: N.T.S.	DATE: 27-02-2024
				DRAWN: [Signature]	CHECKED: [Signature]
				APPROVED: [Signature]	DRG.NO: 4. HME 4250 09
				GR POWER SWITCHGEAR LTD., JEEDIMETLA HYDERABAD-500 055 INDIA	

For EPC Contracts Only

ISOLATOR NC CONTACTS TO BE WIRED AS PER THE FOLLOWING SEQUENCE

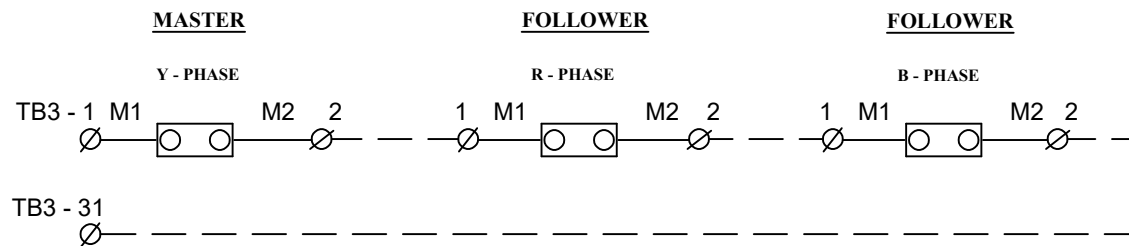

ISOLATOR NO CONTACTS TO BE WIRED AS PER THE FOLLOWING SEQUENCE

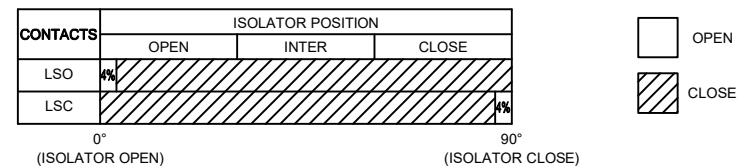
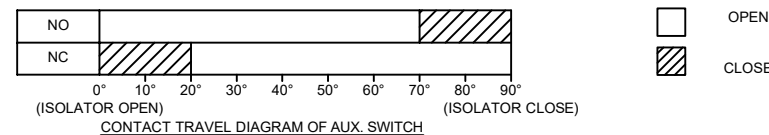
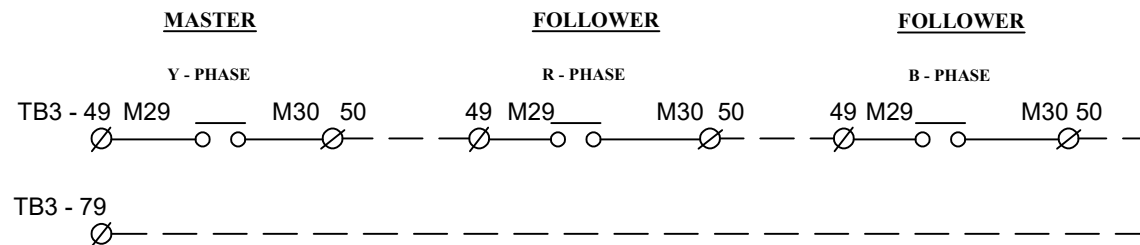

Drawing approval subject to valid vendor registration

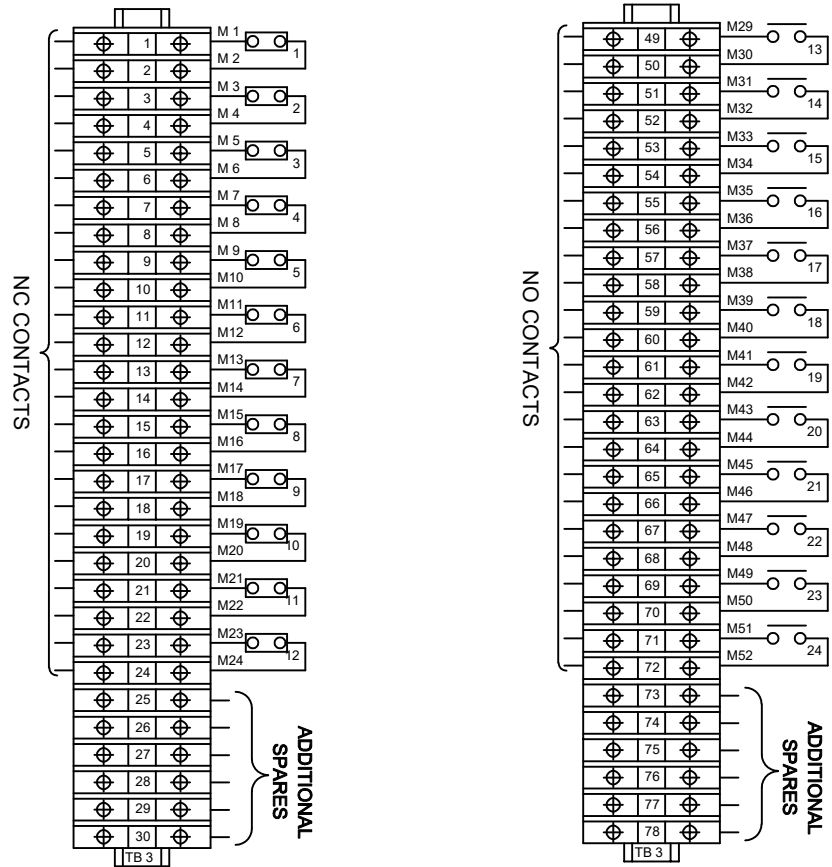

FOR ISOLATOR (FOR MASTER & FOLLOWER)

(12 NO / 12 NC)

Chief Engineer
Projects

NC SPARES

NO SPARES

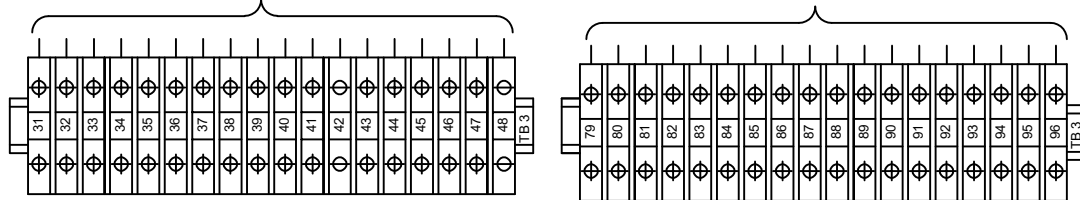

FOR ISOLATOR (IN MASTER OPERATING MECHANISM ONLY)

(12 NO / 12 NC)

REVISIONS			
D	C	B	A

CLIENT : M/s. TRANSMISSION CORPORATION OF ANDHRA PRADESH LIMITED

TITLE: **AUX. SWITCH DETAILS FOR 420 kV ISOLATOR**

SCALE: N.T.S.

DATE: 27-02-2024

DRAWN: [Signature]

CHECKED: [Signature]

APPROVED: [Signature]

DRG.NO: 4. HI 4250 10

REV: []

GR POWER SWITCHGEAR LTD.,
JEEDIMETLA HYDERABAD-500 055 INDIA

For EPC Contracts Only

ISOLATOR NC CONTACTS TO BE WIRED AS PER THE FOLLOWING SEQUENCE

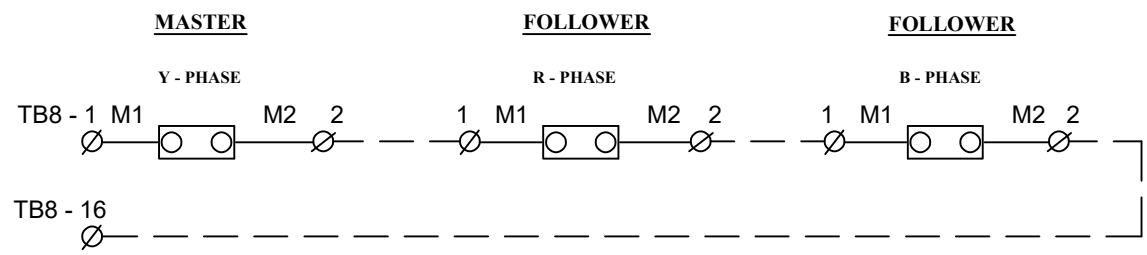

ISOLATOR NO CONTACTS TO BE WIRED AS PER THE FOLLOWING SEQUENCE

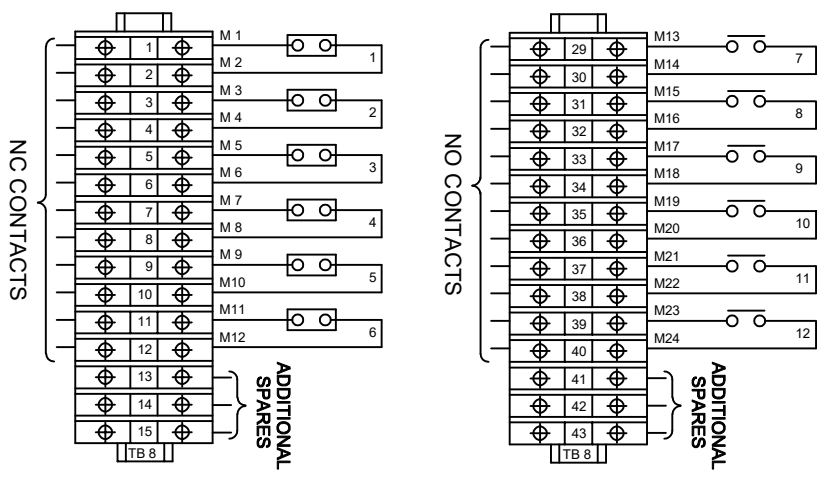
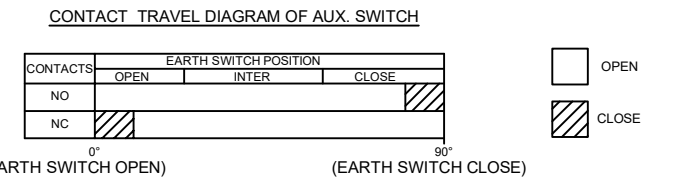
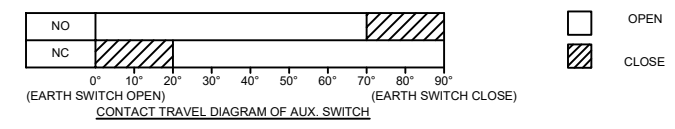
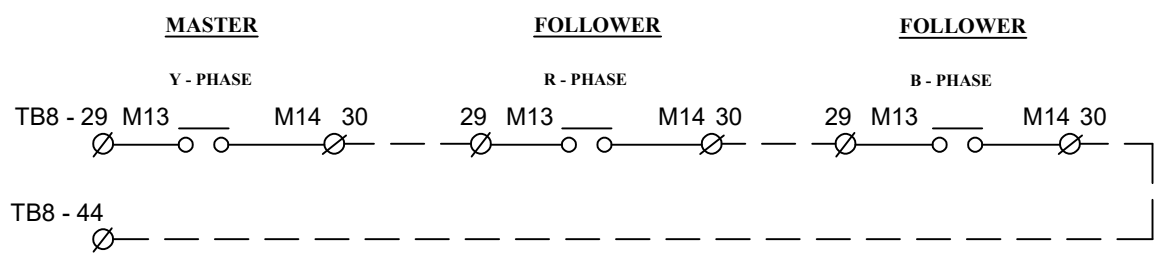

FOR EARTH SWITCH (FOR MASTER & FOLLOWER)
(6 NO / 6 NC)

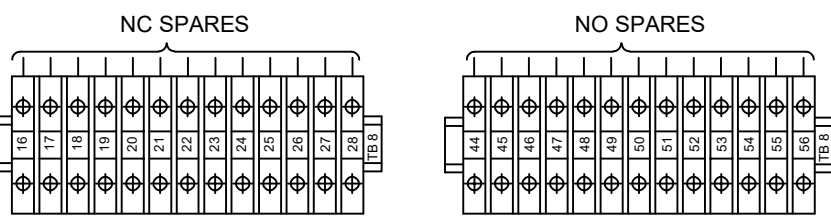

FOR EARTH SWITCH (IN MASTER OPERATING MECHANISM ONLY)
(6 NO / 6 NC)

NOTE : DRAWING APPROVAL SUBJECT TO VALID TYPE TEST REPORTS.
TO BE CHECKED DURING ACCEPTANCE TESTS.

Drawing approval subject to valid vendor registration

Chief Engineer
Projects

REVISIONS			
D	C	B	A

CLIENT : M/s. TRANSMISSION CORPORATION OF ANDHRA PRADESH LIMITED

TITLE: **INTERPOLE LOOPING DETAILS FOR 420 kV ISOLATOR**

SCALE: N.T.S.

DATE: 27-02-2024

DRAWN: [Signature]

CHECKED: [Signature]

APPROVED: [Signature]

DRG.NO: 4. HI 4250 10A

REV: []

GR POWER SWITCHGEAR LTD.,
JEEDIMETLA HYDERABAD-500 055 INDIA

NAME PLATE DETAILS FOR ISOLATOR

For EPC Contracts Only

NAME PLATE DETAILS FOR EARTH SWITCH

 MANUFACTURED & SUPPLIED BY GR POWER SWITCHGEAR LTD., JEEDIMETLA, HYDERABAD - 500 055	
CLIENT :	M/s.TRANSMISSION CORPORATION OF ANDHRA PRADESH LIMITED
PROJECT :	
CONTRACTOR :	
P.O. NO :	
TYPE :	HCB SL. NO : AS APPLICABLE YEAR OF Mfg. : 2024
RATING :	Un 420 KV ; In : 3150 A ; WEIGHT IN KG :
IMPLUSE(UI) :	1425 KV Peak ; SWITCHING(Us) : 1050 KV Peak ;
P.F. :	520 KV rms ; STC(lth) : 63 KA rms ; DURATION : 1 Sec ;
OPERATING MECHANISM :	MOTOR, 3 Ph., 415 V, 0.5 HP
CONTROL VOLTAGE :	220 V DC STANDARD : IEC - 62271-102
CREEPAGE DISTANCE :	31 mm/kV





 MANUFACTURED & SUPPLIED BY GR POWER SWITCHGEAR LTD., JEEDIMETLA, HYDERABAD - 500 055	
CLIENT :	M/s.TRANSMISSION CORPORATION OF ANDHRA PRADESH LIMITED
PROJECT :	
CONTRACTOR :	
P.O. NO :	
TYPE :	VB SL. NO : AS APPLICABLE YEAR OF Mfg. : 2024
RATING :	Un 420 KV ; In : 3150 A ; WEIGHT IN KG :
IMPLUSE(UI) :	1425 KV Peak ; SWITCHING(Us) : 1050 KV Peak ;
P.F. :	520 KV rms ; STC(lth) : 63 KA rms ; DURATION : 1 Sec ;
OPERATING MECHANISM :	MOTOR, 3 Ph., 415 V, 0.5 HP
CONTROL VOLTAGE :	220 V DC STANDARD : IEC - 62271-102
CREEPAGE DISTANCE :	31 mm/kV

NOTE : DRAWING APPROVAL SUBJECT TO VALID TYPE TEST REPORTS.
 TO BE CHECKED DURING ACCEPTANCE TESTS.

Chief Engineer
 Projects

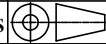
NOTES :

1. ENGRAVED LETTER SIZE : 3 mm
2. LETTER ETCHED WHITE ON BLACK BACKGROUND
3. MATERIAL : ALUMINUM
4. THICKNESS : 1 mm

CLIENT : M/s. TRANSMISSION CORPORATION OF ANDHRA PRADESH LIMITED			
TITLE: NAME PLATE DETAILS FOR 420 kV ISOLATOR & E.S			
SCALE:N.T.S			
DATE			27 - 02 - 2024
DRAWN			
CHECKED			
APPROVED			
DRG.NO:		REV	
4. HZ 4250 11			
 GR POWER SWITCHGEAR LTD., JEEDIMETLA HYDERABAD-500 055 INDIA			

ELEVATION

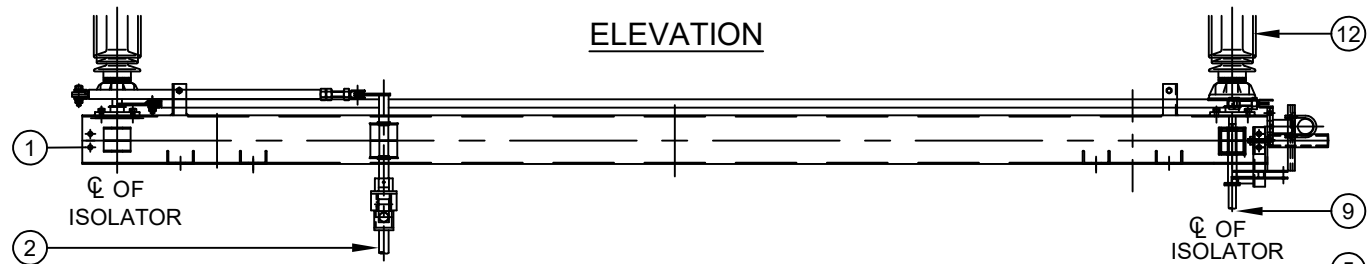

PLAN

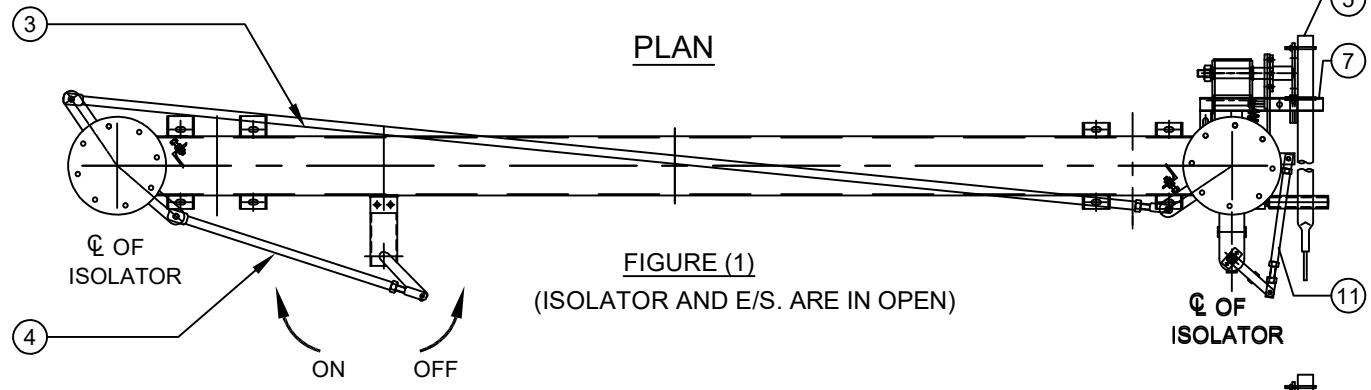

FIGURE (1)
(ISOLATOR AND E/S. ARE IN OPEN)

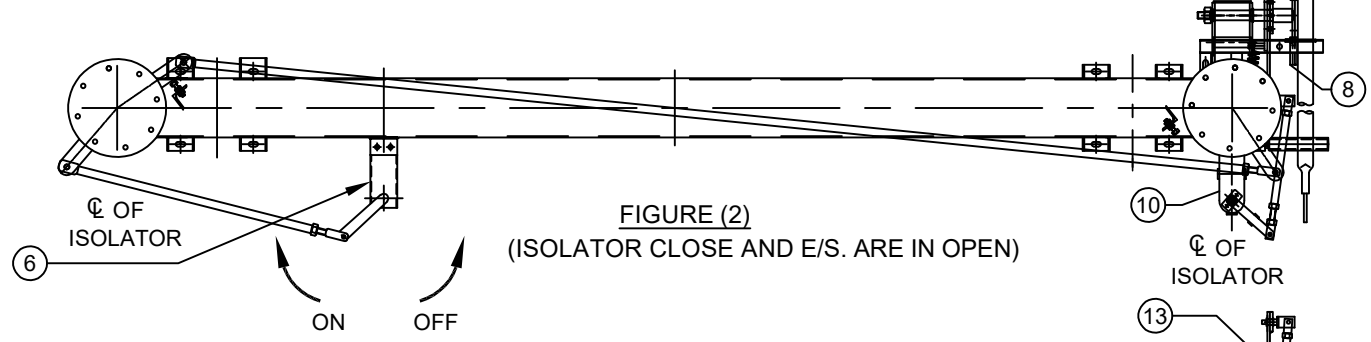

FIGURE (2)
(ISOLATOR CLOSE AND E/S. ARE IN OPEN)

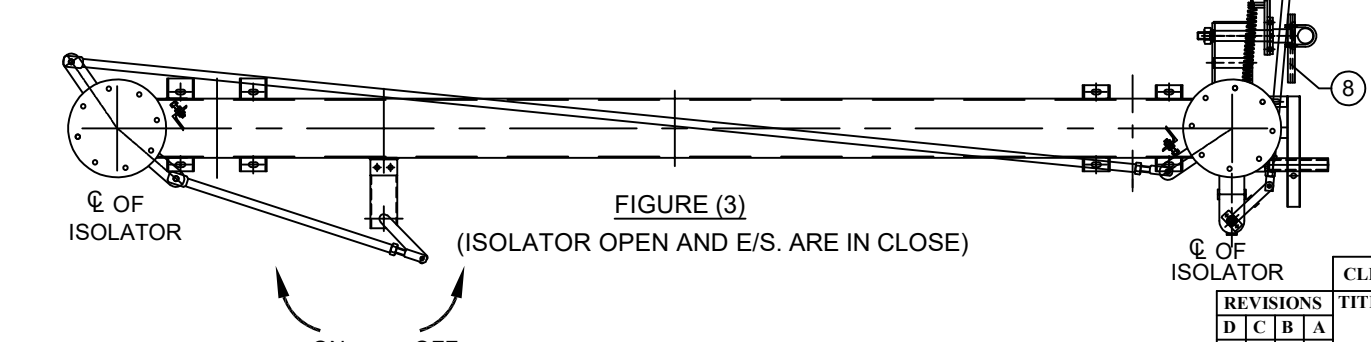

FIGURE (3)
(ISOLATOR OPEN AND E/S. ARE IN CLOSE)

CONSTRUCTION :
 ISOLATOR OPERATING MECHANISM OUT PUT SHAFT IS CONNECTED TO TOP OPERATING MECHANISM OF ISOLATOR (6) THROUGH DOWN OPERATING PIPE OF ISOLATOR (2). TOP OPERATING MECHANISM ONE SIDE IS CONNECTED TO ROTATING INSULATOR STACK (12), THROUGH A LINK TANDEM PIPE (3).
 E.S. OPERATING MECHANISM OUTPUT SHAFT IS CONNECTED TO TOP OPERATING MECHANISM OF E.S. (10) THROUGH DOWN OPERATING PIPE OF E.S. (9) TOP OPERATING MECHANISM IS CONNECTED TO TANDEM PIPE OF E.S. THROUGH LINK PIPE (11).

FUNCTION :
 WHILE ISOLATOR UNDER OPERATION MODE THE MECHANICAL INTERLOCK PIPE (7) WILL ROTATE ALONG WITH INSULATOR STACK (12) INTERLOCK LEVER (8) WILL ROTATE ALONG WITH E.S. MOVING CONTACT.

REFER FIG. (1) :- WHEN ISOLATOR IS IN "OFF" POSITION THE MECHANICAL INTERLOCK PIPE (7) WILL PERMIT THE CLOSE OR OPEN EARTH SWITCH.

REFER FIG. (2) :- WHEN ISOLATOR IS IN "ON" POSITION MECHANICAL INTERLOCK PIPE (7) WILL NOT PERMIT THE EARTH - SWITCH MOVING CONTACT (5) TO CLOSE.

REFER FIG. (3) :- WHEN EARTH SWITCH IS IN "ON" POSITION THE INTERLOCK LEVER (8) WILL NOT PERMIT THE INSULATOR STACK (12) TO CLOSE.

- PART LIST :**
1. BASE CHANNEL
 2. DOWN OPERATING PIPE FOR ISOLATOR
 3. LINK TANDEM PIPE
 4. TOP OPERATING MECHANISM LINK PIPE
 5. E/S. MOVING CONTACT
 6. TOP OPERATING MECHANISM FOR ISOLATOR
 7. MECHANICAL INTERLOCK PIPE
 8. INTERLOCK LEVER
 9. DOWN OPERATING PIPE FOR E.S.
 10. TOP OPERATING MECHANISM FOR E.S.
 11. TOP OPERATING MECHANISM LINK PIPE
 12. INSULATOR STACK
 13. COUNTER SPRING

For EPC Contracts Only

NOTE : DRAWING APPROVAL SUBJECT TO VALID TYPE TEST REPORTS TO BE CHECKED DURING ACCEPTANCE TESTS.

Drawing approval subject to valid vendor registration

Chief Engineer
Projects

CLIENT : M/s. TRANSMISSION CORPORATION OF ANDHRA PRADESH LIMITED

REVISIONS			
D	C	B	A

TITLE:
**MECHANICAL INTERLOCK BETWEEN
FOR 420 kV ISOLATOR & E/S**

SCALE:N.T.S	
DATE	27 - 02 - 2024
DRAWN	
CHECKED	
APPROVED	

**GR POWER SWITCHGEAR LTD.,
JEEDIMETLA HYDERABAD-500 055 INDIA**

DRG.NO:
4. HZ 4250 12

REV

NOTE : DRAWING APPROVAL SUBJECT TO VALID TYPE TEST REPORTS.

For EPC Contracts Only TO BE CHECKED DURING ACCEPTANCE TESTS.

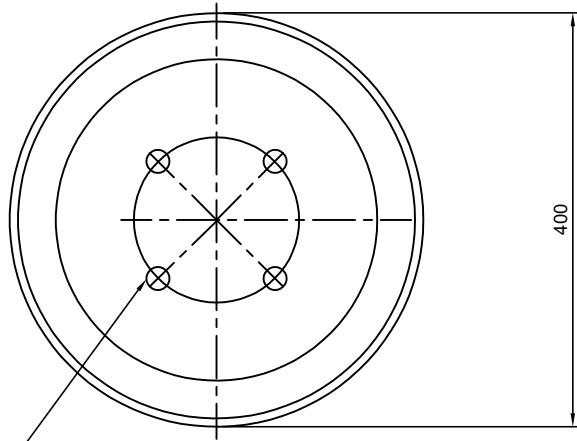

ELEVATION

4 NOS Ø 18 HOLES ON 127P.C.D.

CORONA SHIELD ON INSULATORS

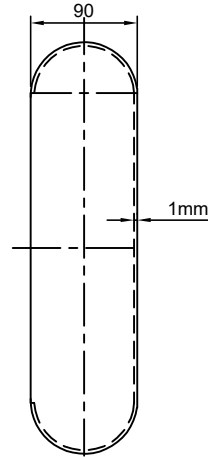

SIDE VIEW

Drawing approval subject to valid vendor registration

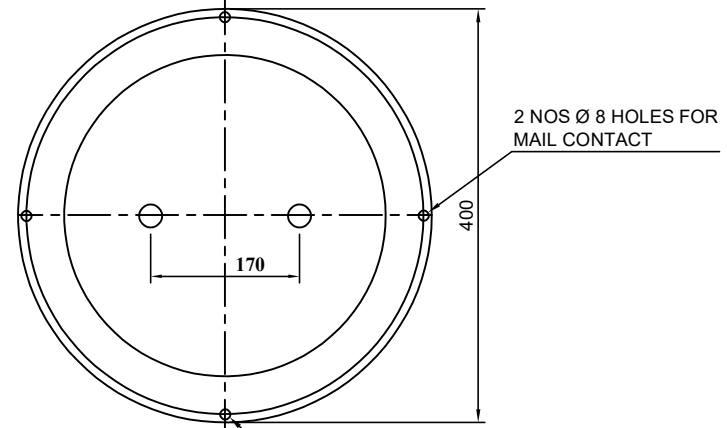

ELEVATION

2 NOS Ø 8 HOLES FOR FEMALE CONTACT

CORONA SHIELD ON MALE CONTACTS

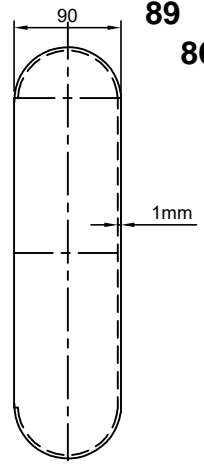

SIDE VIEW

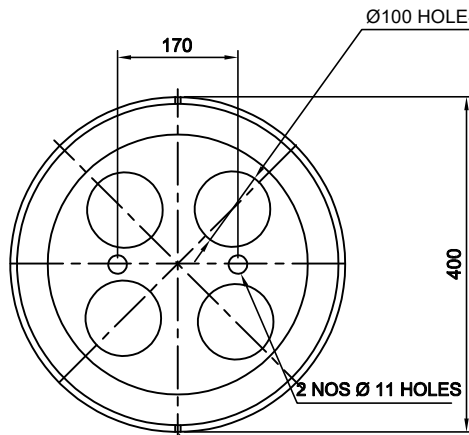

ELEVATION

2 NOS Ø 8 HOLES

CORONA SHIELD ON FEMALE CONTACTS

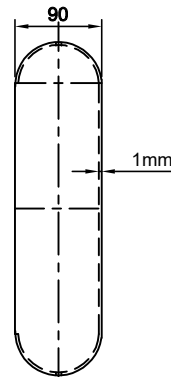

SIDE VIEW

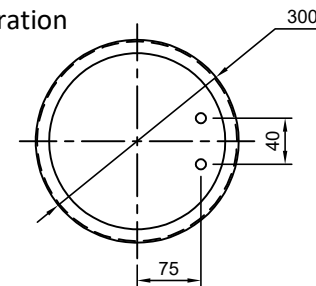

ELEVATION

CORONA SHIELD ON EARTH SWITCH

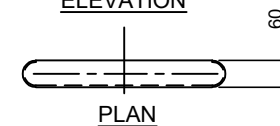

PLAN

Chief Engineer
Projects

NOTES :

1. ALL DIMENSIONS ARE IN MILLIMETERS
2. REMOVE EXCESS WELDING MATERIAL WITH TUBE DIAMETER
3. MANUFACTURING TOLERANCE FOR TUBE BENDING :
UP TO 50 mm --- ±9%; 51 TO 100 mm --- ±7%
4. MATERIAL SPECIFICATION CONFIRM TO ALLOY & TIMBER 63401 (E91E) WP
AS PER IS : 5082 - 1981

REVISIONS

D C B A

CLIENT : M/s. TRANSMISSION CORPORATION OF ANDHRA PRADESH LIMITED

TITLE:

CORONA SHIELD DETAILS

SCALE:N.T.S

DATE 27 - 02 - 2024

DRAWN

CHECKED

APPROVED



GR POWER SWITCHGEAR LTD.,
JEEDIMETLA HYDERABAD-500 055 INDIA

DRG.NO:

4. HO 4250 13

REV

GUARANTEED TECHNICAL PARTICULARS FOR 420 KV ISOLATOR

CLIENT:	M/s. TRANSMISSION CORPORATION OF ANDHRA PRADESH LIMITED
---------	---

Chief Engineer
Projects

S.No.	Description	DATA
1	Manufacturer's name, address and country	GR POWER SWITCHGEAR LIMITED, "KOTAMMA BHAVAN", Plot No.27/B, I.D.A., IV Phase, Jeedimetla HYDERABAD - 500 055. INDIA
2	Type Designation	Two Post Rotating Horizontal Centre Break "HCB"
3	Applicable Standard	IEC-62271-102
4	Outdoor/Indoor	Outdoor
5	Rated voltage	420 KV
6	Rated frequency	50 Hz
7	No. of poles	Three
8	Whether all three poles are ganged together mechanically/electrically	Electrically ganged operation
9	Rated normal current	
	a) Under site conditions	3150 Amps
	b) Under normal conditions as per IS/IEC	3150 Amps
10	Rated short time current for 1 sec. (KA rms)	63 KA
11	Rated peak short circuit current of (KA) and time	
	a) Isolator	157.5 KA peak
	b) Earthing Switch	157.5 KA peak
12	Rated short circuit making current	Earth Switch are class E0 hence it is not applicable
13	Rated magnetising/current/capacitive current capacity	0.7 Amps at 0.15 p.f. (Assigned)
14	Temperature rise over ambient temperature 50 deg. C at site corresponding to	
	a) Maximum continuous current (deg. C)	Within the limits of values as specified in Table 4 of (Page No.2) of IS: 9921 (Part II) of 1982 derated to 50 deg. C
	b) Short time current	

NOTE : DRAWING APPROVAL SUBJECT TO VALID TYPE TEST REPORTS.

TO BE CHECKED DURING ACCEPTANCE TESTS.

Drawing approval subject to valid vendor registration

S.No.	Description	DATA
15	<p>c) indicate the temperature value after derating</p> <p>Rated Insulation levels</p> <p>a) 1.2/50 microsecond lightning impulse withstand voltage</p> <p> i) to earth (KV peak)</p> <p> ii) across the open isolator (KV peak)</p> <p> - one terminal lightning impulse</p> <p> - opposite terminal power frequency (KV peak)</p> <p>b) 250/2500 microsecond switching impulse withstand voltage</p> <p> i) to earth (KV peak)</p> <p> ii) across the open isolator (KV peak)</p> <p> - one terminal lightning impulse</p> <p> - opposite terminal power frequency (KV peak)</p> <p>c) 1 minute power frequency withstand voltage</p> <p> - to earth</p> <p> - across the terminal of open isolator</p>	<p>75 deg. C at 45 deg ambient 65 deg. C at 50 deg ambient</p> <p>1425 KV (peak)</p> <p>1425 KV (peak)</p> <p>240 KV (peak)</p> <p>1050 KV peak</p> <p>900 KV (peak)</p> <p>345 KV (peak)</p> <p>520 KV (rms)</p> <p>610 KV (rms)</p> <p>320 KV</p> <p>Less than 1000 microvolts@267kVrms</p> <p>1600 N</p> <p>550 N</p> <p>Less than 12 secs.</p> <p>Less than 12 secs.</p> <p>Jaw & Fist type slide-in contacts</p> <p>Hard drawn Electrolytic Copper Strips Contacts: Hard drawn Electrolytic Copper. Contact arms are Electrolytic grade Aluminium drawn section box type</p>
16	Corona extinction voltage (KV rms)	320 KV
17	Radio interference voltage at 0.5 MHz, 1.0 MHz, 1.5 MHz and 2 MHz at... KV (micro-volts and corresponding KV rms)	Less than 1000 microvolts@267kVrms
18	Rated mechanical terminal loads for horizontal break Isolator (Newton)	
	a) Longitudinal	1600 N
	b) Transverse	550 N
19	Total operating time	
	a) Opening time	Less than 12 secs.
	b) Closing time	Less than 12 secs.
20	Main Contacts (fixed and moving)	
	a) Type	Jaw & Fist type slide-in contacts
	b) Material	Fixed: Moving:
		Hard drawn Electrolytic Copper Strips Contacts: Hard drawn Electrolytic Copper. Contact arms are Electrolytic grade Aluminium drawn section box type

NOTE : DRAWING APPROVAL SUBJECT TO VALID TYPE TEST REPORTS.

TO BE CHECKED DURING ACCEPTANCE TESTS.

Drawing approval subject to valid vendor registration

S.No.	Description	DATA
21	c) Whether contacts are silver plated d) Thickness of silver coating (mm) e) Contact area (sq.mm) f) Contact pressure (kg/cm.sq) g) Current density (Amp/cm.sq) - Moving blade - Terminal pad - Contacts - Terminal connectors h) Number of operations which the isolator can make without deterioration of contacts Auxiliary contacts a) Main Isolator i) Total number for purchaser's use - NO - NC ii) Rated voltage iii) Rated continuous current iv) Rated breaking current b) Earth Switch i) Total number for purchaser's use - NO - NC ii) Rated voltage iii) Rated continuous current iv) Rated breaking current c) Whether arcing contacts provided and if so give type and material used	Yes. 25 microns Line Contact High Pressure } As per standard 1000 operations 12 Nos. 12 Nos. 220 V DC 10 Amps 2 Amps DC with time constant of not less than 20 ms Chief Engineer Projects 6 Nos. 6 Nos. 220 V DC 10 Amps 2 Amps DC with time constant of not less than 20 ms Not Applicable
22	Insulators a) Name of Manufacturer, address & country b) Type (Solidcore) c) Applicable standard d) Number of insulator stacks per pole	Not Applicable

NOTE : DRAWING APPROVAL SUBJECT TO VALID TYPE TEST REPORTS.

TO BE CHECKED DURING ACCEPTANCE TESTS.

Drawing approval subject to valid vendor registration

S.No.	Description	DATA
	e) Number of insulators per stack f) 1 minute power frequency withstand voltage g) Lightning impulse withstand voltage (KV peak) h) Switching impulse withstand voltage/Visible Voltage discharge (KV peak) I) Corona extinction voltage (KV rms) j) Creepage distance k) Weight of each post insulator per stack l) Tensile strength m) Compressive strength n) Torsional strength o) Cantilever strength p) Pitch circle dia (mm)	NOT IN SCOPE OF M/S GR POWERSUPPLY Chief Engineer Projects
23	Minimum phase to phase clearance (mm)	7000 mm
24	a) Minimum phase to ground clearance (mm)	Equal to the dry arcing distance of the insulator selected
	b) Minimum between phases when isolator is open	3400 mm
25	Types of bearings	Ball Bearings
26	Locations of bearings	Below the rotating post insulators. One at the top and one at the bottom of the bearing housing
27	Type of lubricant for bearings	Grease lubricated for life time
28	Terminal clamps & connectors	
	a) Manufacturer's name	
	b) Applicable standard	
	c) Material	
	- Clamp body	
	- Bolts and Nuts	
	- Spring washers	
	- Liners if any	
	d) Rated current (Amp)	NOT IN SCOPE OF M/S GR POWERSUPPLY
	e) Rated terminal load (kg)	

NOTE : DRAWING APPROVAL SUBJECT TO VALID TYPE TEST REPORTS.

TO BE CHECKED DURING ACCEPTANCE TESTS.

GR POWER SWITCHGEAR LTD

WO.NO - 4250

S.No.	Description	DATA
29	<p>f) Weight of clamp complete with hardware (kg)</p> <p>g) Radio interference voltage (micro volts)</p> <p>h) Corona extinction voltage</p> <p>l) Maximum allowable span for aluminium tube with outer diameter of 114.2 mm and inside diameter of 9718 mm on equipment terminal pad with rated fault current and 7 m & 4.5 m phase to phase spacing for 420 KV & 245 KV Isolators respectively</p> <p>Operating mechanism</p> <p>a) Type of operating mechanism</p> <p>b) Name, address & country of manufacturer</p> <p>c) Whether interpole cabling included in scope of supply</p> <p>d) Whether separate operating mechanism provided for operation of isolator pole and earthing switch</p> <p>e) Electrical Operation</p> <ul style="list-style-type: none"> - Motor type (AC/DC) - Applicable standard - Rated voltage and current (Volt, Amp) - Type of enclosure and method of cooling - Power required for closing and opening operation - Running time of motor for closing and opening operation - Control supply for motor volt, power consumption <p>f) Type of manual operating mechanism for isolator pole and earthing switch</p> <p>g) Force required to operate</p> <p>h) Whether padlocking are included as per the specification</p> <p>l) Type of manual device</p>	<p>Chief Engineer Projects</p> <p>Main Switch: Motor operated Earth Switch: Motor operated</p> <p>GR POWER SWITCHGEAR LIMITED, Plot No.27/B, IDA, IV Phase, Jeedimetla, Hyderabad - 500 055. India</p> <p>Yes.</p> <p>Yes. Drawing approval subject to valid vendor registration</p> <p>AC - Squirrel Cage Induction Motor</p> <p>IS: 325</p> <p>415 V, 3 phase, 1.02 Amps</p> <p>IP - 55</p> <p>0.373 KW</p> <p>10 - 12 secs.</p> <p>415 V, 0.373 KW</p> <p>Main Switch: Emergency manual operation through operating handle Earth Switch: -do-</p> <p>30 kgm</p> <p>No</p> <p>Refer (f) above</p>
30	<p>Interlocking</p> <p>a) Details of mechanical interlock between isolator and earth switch enclosed (Yes/No)</p> <p>b) Details of electrical interlock for isolator and earth</p>	<p>Yes.</p>

NOTE : DRAWING APPROVAL SUBJECT TO VALID TYPE TEST REPORTS.

TO BE CHECKED DURING ACCEPTANCE TESTS.

S.No.	Description	DATA
31	<p>switch enclosed. (Yes/No)</p> <p>c) Details of electrical interlock provided to satisfy Cl. 8.4 of Technical Specification. (Yes/No)</p> <p>d) Details of electrical scheme to provide remote alarm for pole discrepancy. (Yes/No)</p> <p>e) Details of electrical interlock to bring back all three poles to open position in case any pole fails to close within specified time (Yes./No)</p> <p>f) Details of provisions to cut of supply to the motor during manual operation and provision for de-coupling the motor. (Yes./No)</p> <p>g) Arrangement provided to prevent electrical or manual operation unless interlock are satisfied</p> <p>h) Resistance of operating and interlock coils</p> <p>Control Cabinets/Marshalling box/MOM Panel</p> <p>a) Manufacturer's name, address & country</p> <p>b) Standard to which conforming</p> <p>c) Thickness of sheet (mm) Top/Bottom/Side/Back/Door leaf</p> <p>d) Degree of protection provided</p> <p>e) Colour of finish paint</p> <p>- Outside</p> <p>- Inside</p> <p>f) Control wiring</p> <p>- Current rating (Amp)</p> <p>- Voltage rating (Volts)</p> <p>- Size and material of conductor</p> <p>g) Terminal blocks</p> <p>- Name & address of manufacturer</p> <p>- Current rating (Amp)</p> <p>- Voltage rating (Volts)</p> <p>h) Space heater rating at 240 Volts (watts)</p> <p>I) Whether all cabling for wiring out contacts to control cabinet included in scope of supply</p>	<p>Yes.</p> <p>Yes.</p> <p>Yes.</p> <p>Yes.</p> <p>Yes.</p> <p>Yes.</p> <p>Yes.</p> <p>1.885 killo-ohms for operating coil 6.19 killo-ohms for interlocking coil</p> <p>GR POWER SWITCHGEAR LIMITED, Plot No.27/B, I.D.A., IV Phase, Jeedimetla, Hyderabad - 500 055. INDIA</p> <p>IS /IEC 60529</p> <p>3 mm thick aluminium sheet</p> <p>IP-55</p> <p>Natural Finish</p> <p>Natural Finish</p> <p>16 Amps</p> <p>1100 V</p> <p>2.5 sq.mm Copper</p> <p>STUD TYPE OF ELMEX OR ITS EQUIVALENT</p> <p>25 Amps</p> <p>1100 V</p> <p>80 Watts</p> <p>Yes.</p> <p>Chief Engineer Projects</p>

NOTE : DRAWING APPROVAL SUBJECT TO VALID TYPE TEST REPORTS.

TO BE CHECKED DURING ACCEPTANCE TESTS.

S.No.	Description	DATA
32	j) Provision of lock with keys (Yes/No)	Yes.
	k) Dimensioned drawing (External & Internal)	Yes. Enclosed
	l) Control cabinet/marshalling box internal lighting lamp and door switch for controlling.	Yes. Enclosed
	m) Weight	80 kgs (approx.)
	n) Plinth mounted/structure mounted	Structure mounted
	Size and Weight	
	a) Weight of each pole	Please refer enclosed drawings
	b) Space requirement I.e. length.	-do-
	c) Dimensions	
	- 3 phase isolator	-do-
- Isolator-cum-earthing switch (mm x mm x mm)	-do-	
d) Size of largest part	To be submitted later	
33	A. TANDEM PIPE	
	a) Size	32NB
	b) Class	Class B
	c) Material	GI
	B. DOWN PIPE	
	a) Internal/External dia (mm)	50NB
	b) Class	"B"
c) Material	G. I.	
34	Enclosures to the bidding document.	
	Whether the following are enclosed (Yes./No)	
	a) Type test report for main equipment and auxiliaries	Yes.
	b) Drawings as per Section-General	Yes.
	c) Technical literature for isolator, operating mechanism and support insulators.	Yes.

for GR POWER SWITCHGEAR LTD.,



Authorized Signatory

NOTE : DRAWING APPROVAL SUBJECT TO VALID TYPE TEST REPORTS.

TO BE CHECKED DURING ACCEPTANCE TESTS.

Drawing approval subject to valid vendor registration

Chief Engineer
Projects

Drawing approval subject to valid vendor registration