

245 KV CURRENT TRANSFORMER TYPE: IMB 245

CLIENT:
(AS APPLICABLE)

END CUSTOMER:
APTRANSCO

W.O. NO.:
(AS APPLICABLE)

PROJECT:
(AS APPLICABLE)

P.O. NO.:
(AS APPLICABLE)

QTY.:
(AS APPLICABLE)

CT RATIO:
600/1

We reserve all rights in this document and in the information contained there in reproduction, use or disclosure to third parties without express authority is strictly forbidden ©ABB.

Ⓐ New drg. prepared.

Ⓑ Change in sr no. 3

This drawing is a COMPUTER ORIGINAL and does not require signature for its authentication

Drawing approval subject to valid vendor registration

SR. NO.	REFERENCE OF STD DRGS/ DOCUMENTS	REV.	DESCRIPTION
1.	1HYT903320-048	A	GENERAL ARRANGEMENT
2.	1HYT903320-049	A	RATING PLATE
3.	1HYT903320-050	B	SECONDARY TERMINAL BOX

Chief Engineer/Construction

NOTE : DRAWING APPROVAL SUBJECT TO VALID TYPE TEST REPORTS, TO BE CHECKED DURING ACCEPTANCE TESTS.

Prepared: SR	Checked: PDS	Approved: SN
Without Sep. PL.: <input type="checkbox"/>	Same PL. Same No.: <input type="checkbox"/>	Sep. PL. Other No.: <input type="checkbox"/>
Derived by:	Supersedes:	Supersedes by:
A 2021-01-12		
B 2021-01-21		

LIST OF DOCUMENTS FOR IMB 145 TYPE CT



Scale NTS

T.Sh. 1

Sheets 1



1HYT903320-047

This document is COMPUTER ORIGINAL and does not need signature for its authentication

Revision Details:
A New drg. prepared.

We reserve all rights in this document and in the information contained therein. Reproduction, use or disclosure to third parties without express authority is strictly forbidden. © ABB

Drawing approval subject to valid vendor registration

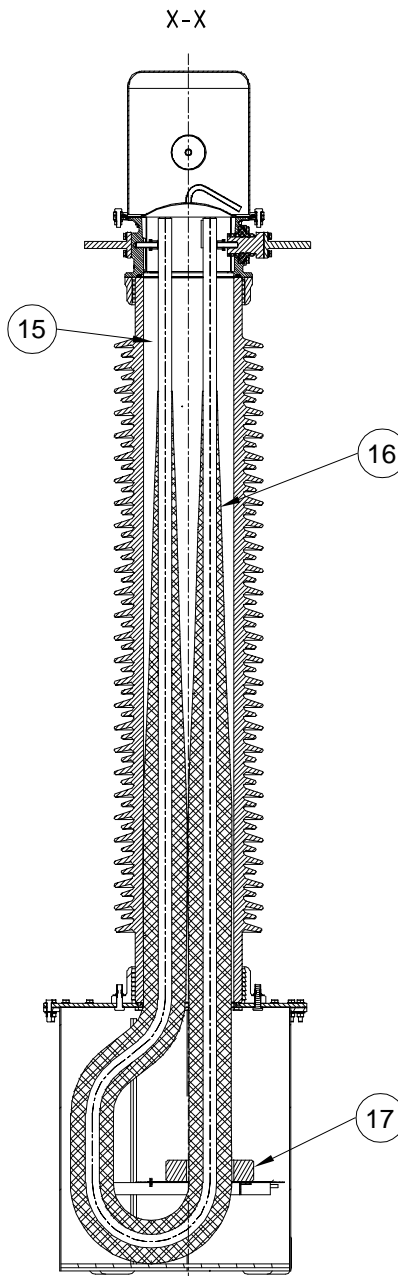
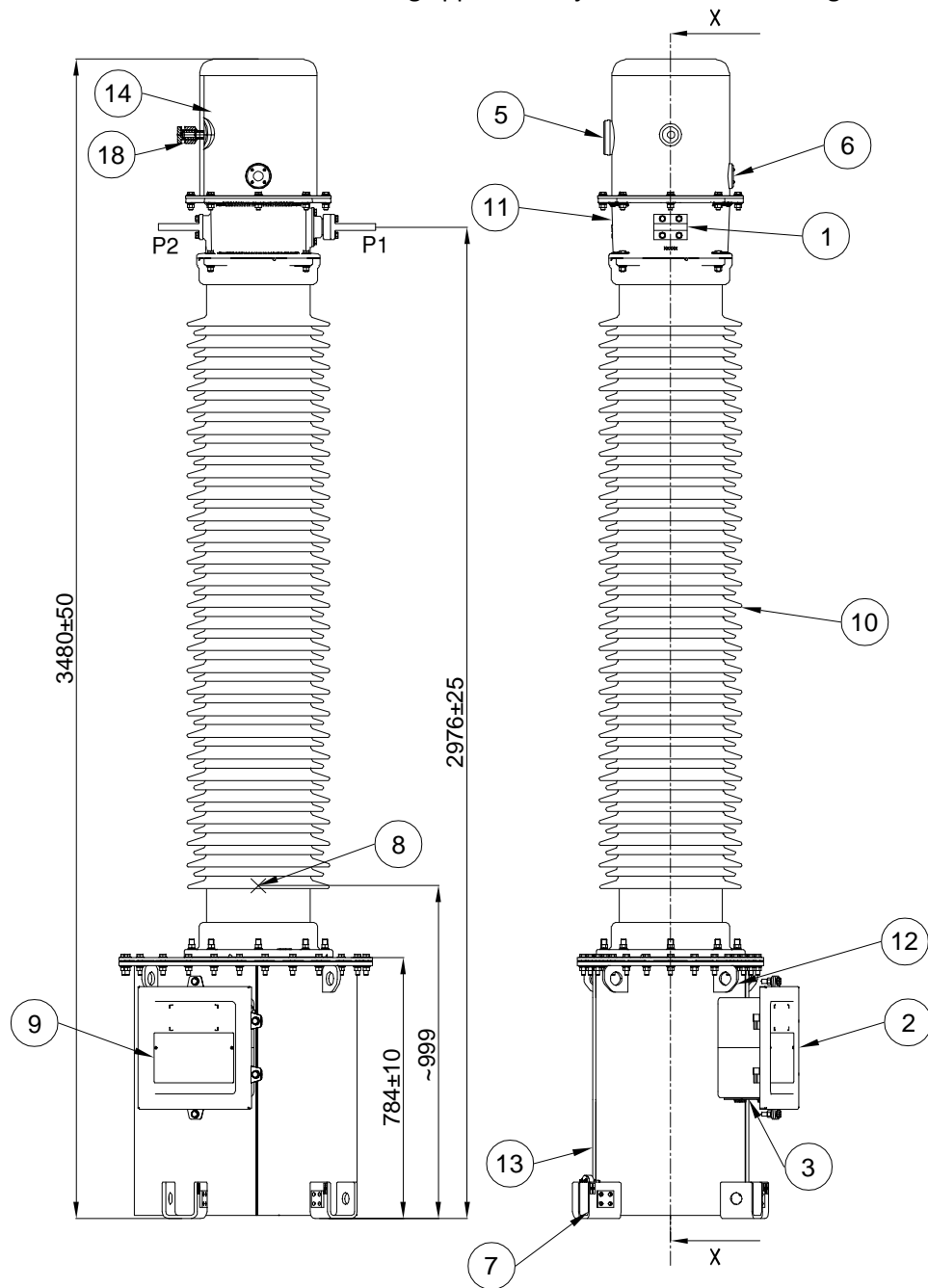

DETAILS OF LIFTING LUG (12)

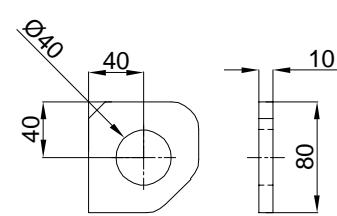

DETAILS OF EARTHING TERMINAL (7)

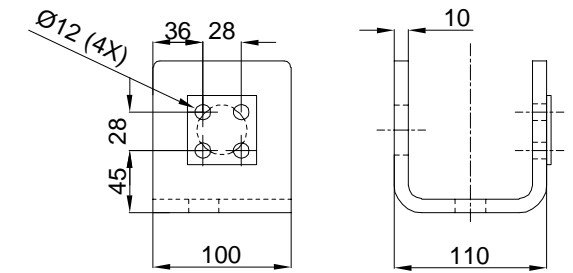

DETAILS OF PRIMARY TERMINAL (1)

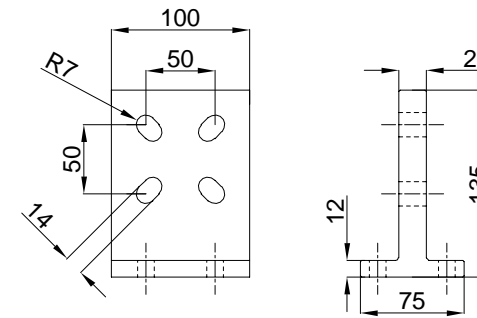

*HOT DIP GALVANISED ON OUTER SURFACE & PAINTED ON INNER SURFACE
INNER SURFACE PAINTED WITH OIL RESISTIVE PAINT

18	PRESSURE RELEASE DEVICE	-	SS / BRASS
17	CORE STACK	-	-
16	PRIMARY WINDING	-	PRIMARY CONDUCTOR (ALU)
15	TRANSFORMER OIL	~140kg	EHV GRADE - IEC:60296
14	OIL EXPANSION SYSTEM	1	TANK - ALU. EXP. SYSTEM - N2 GAS.
13	BOTTOM TANK AND TANK COVER	1	M.S HDG*
12	LIFTING LUG	4	M.S HDG*
11	CONNECTION HEAD	1	ALU.
10	INSULATOR	1	PORCELAIN
9	NAME PLATE	1	ALU.
8	CENTRE OF GRAVITY	-	-
7	EARTH CLAMP	4	S.S. WELDED OVER M.S.
6	OIL LEVEL INDICATOR	1	TOUGHENED GLASS
5	OIL FILLING COVER	1	ALU.
4	OIL DRAIN PLUG WITH BLANKING PLATE	1	M.S HDG*
3	REMOVABLE UNDRILLED GLAND PLATE	1	M.S HDG*
2	SECONDARY TERMINAL BOX	1	M.S HDG*
1	PRIMARY TERMINAL	2	ALU.
Sr. No.	Item Description	Qty.	Material

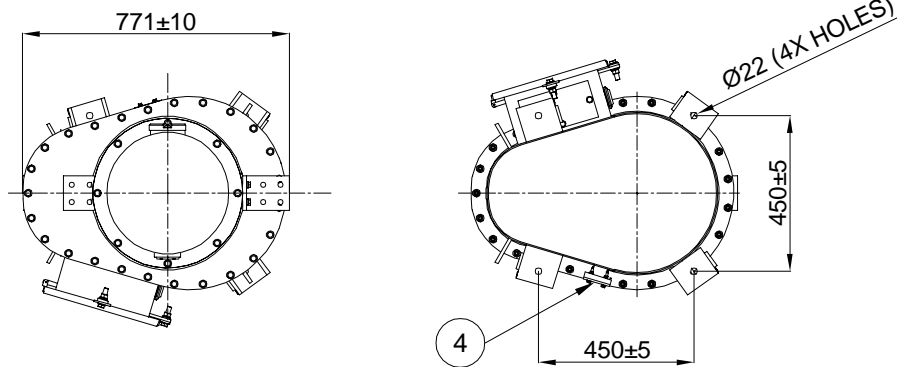

NOTES:

Chief Engineer/Construction

- 1) DEVIATION FOR DIMENSIONS WITHOUT SPECIFIED TOLERANCES AS PER IS: 2102 - (EXTRA COARSE).
- 2) ALL NUTS, BOLTS AND WASHERS ARE OF STAINLESS STEEL/ MS HOT DIP GALVANIZED
- 3) ALL DIMENSIONS ARE IN mm.
- 4) TOTAL WEIGHT 1050 kg approx.
- 5) CREEPAGE DISTANCE 6125 mm.
- 6) ALL FERROUS PARTS EXPOSED TO ATMOSPHERE ARE HOT DIP GALVANIZED.
- 7) GENERAL TOLERANCE AS PER IS:2768-C

NOTE : DRAWING APPROVAL SUBJECT TO VALID TYPE TEST REPORTS, TO BE CHECKED DURING ACCEPTANCE TESTS.

Revision		245 kV OUTDOOR CURRENT TRANSFORMER TYPE IMB 245	GENERAL ARRANGEMENT DRAWING (Small Tank)	Prepared: SR	Checked: SNP	Approved: SN	file: 3320-048	Total sh. 1
A	2021-01-12			ABB APPSIL			1HYT903320-048	Sh.No. 1

Drawing approval subject to valid vendor registration

250

ABB Current transformer APPSIL Production year - YYYY Made in India

Serial number	nnnnnnn	Type	IMB 245	Frequency	50 Hz
Insulation level	245/460/1050	Standard	IEC: 61869-1,2	Temperature range	-5 to +50 °C
Rated pri. normal current	600A	Total mass(Approx)	1050 kg	Total creepage minimum	6125mm
Max continous primary current	720A	Insulation oil(Approx)	140 kg	Ith	40/1 kA/s
GA Drawing	1HYT903320-048	Suitable for Hot line washing	Yes	Idyn	100 kAp



RATIO	600/1
CORE-1	1S1-1S2
CORE-2	-
CORE-3	-
CORE-4	-
CORE-5	-

AUX. REACTOR CONNECTION DETAIL FOR CORE ONLY
 1.CONNECT SHORTING LINK BETWEEN ____ FOR THE RATIO OF ____ RESPECTIVELY. TAKE OUTPUT FROM ____.
 2.DO NOT CONNECT SHORTING LINK FOR THE RATIO OF ____.

CORE	CORE-1	CORE-2	CORE-3	CORE-4	CORE-5
I A	600/1	-	-	-	-
Vk V/ B VA	5	-	-	-	-
CI	0.2S	-	-	-	-
ISF/ALF	<5	-	-	-	-
Io mA	-	-	-	-	-
Rct Ω	-	-	-	-	-

END CUSTOMER: APTRANSCO
 ABB WORKS ORDER NO: (AS APPLICABLE)
 PROJECT: (AS APPLICABLE)

Caution 1)Ensure D3(Tan Delta) Bushing connection with Earth
 2)Secondary terminals must be short circuited before burden is disconnected

165

Serial number nnnnnnn to be decided when manufactured
 Production year yyyy = Actual year,date & month of Production
 Material: Aluminium 2mm Thk.
 Letter height 3 mm

NOTE : DRAWING APPROVAL SUBJECT TO VALID TYPE TEST REPORTS, TO BE CHECKED DURING ACCEPTANCE TESTS.

Chief Engineer/Construction

Revision		245 kV OUTDOOR CURRENT TRANSFORMER TYPE IMB 245	RATING PLATE	Prepared: SR	Checked: PDS	Approved: SN	File: 3320-049	Total sh. 1
A	2021-01-12			ABB APPSIL			1HYT903320-049	Sh.No. 1

This drawing is a COMPUTER ORIGINAL and does not require signatures for its authentication

Revision Details:
 (A) New drg prepared.

We reserve all rights in this document and in the information contained there in. Reproduction, use or disclosure to third parties without express authority is strictly forbidden. © ABB.

A

B

C

D

E

F

A

B

C

D

E

F

This document is COMPUTER ORIGINAL and does not need signature for its authentication

Revision Details:
 (B) Gland plate thickness added BOM created reactor detail added

Revision Details:
 (A) New Drawing prepared

We reserve all rights in this document and in the information contained there in. Reproduction or disclosure to third parties without express authority is strictly forbidden @ABB.

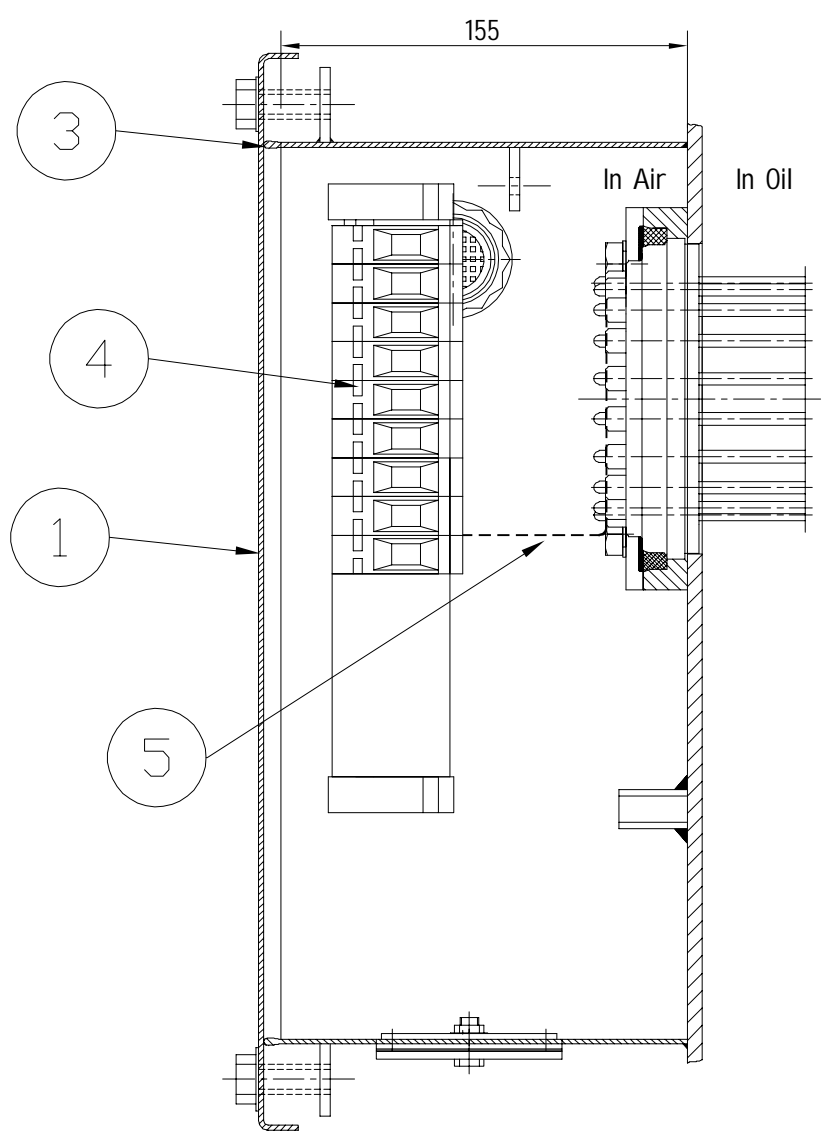

Section-AA

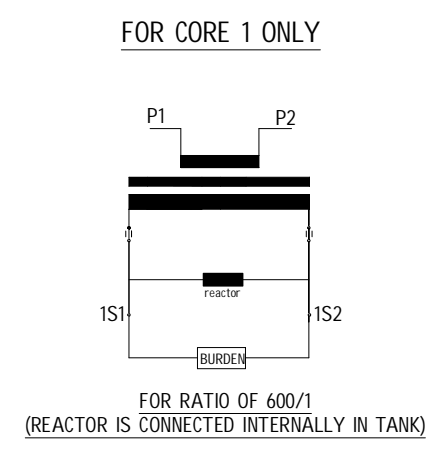
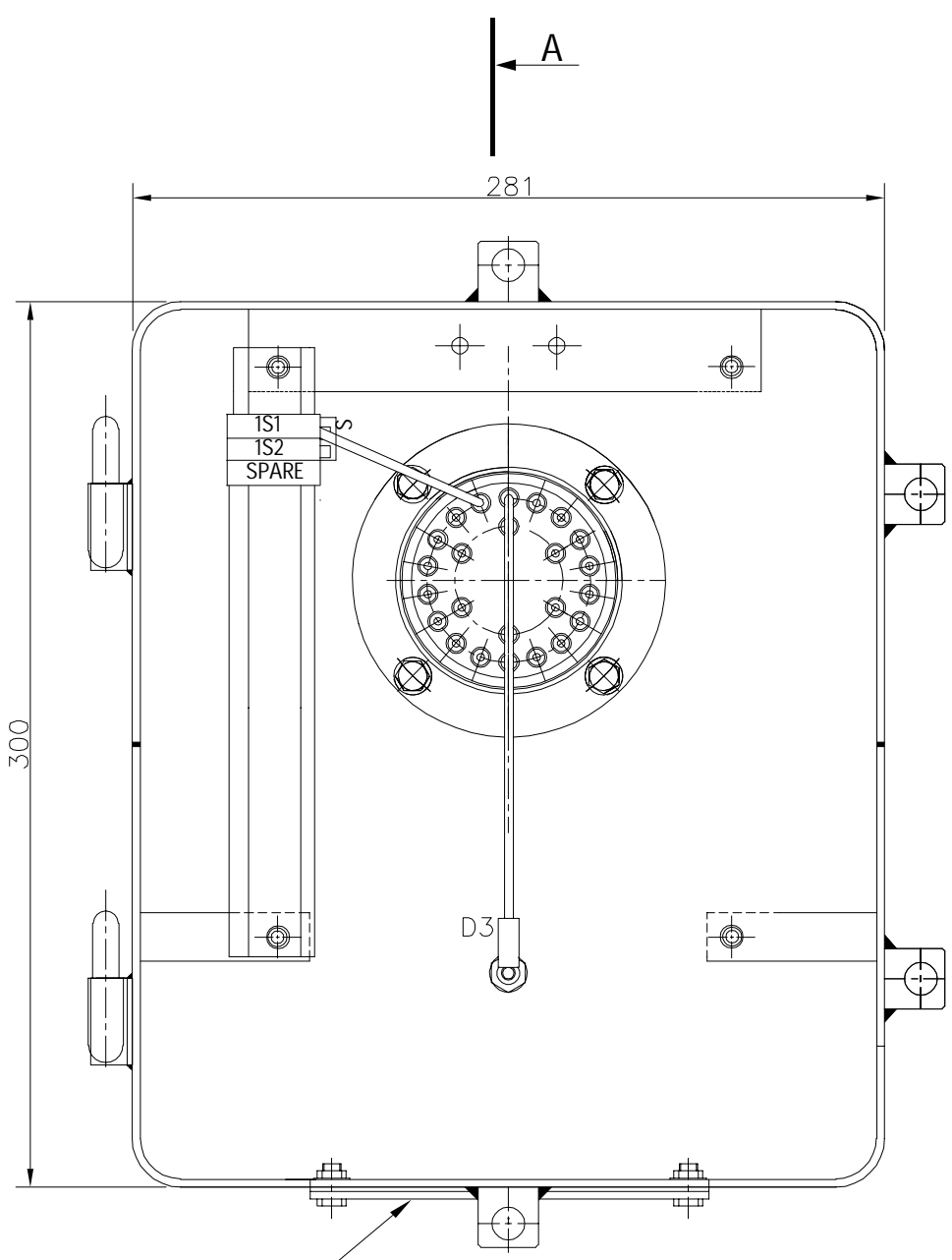

NOTE : DRAWING APPROVAL SUBJECT TO VALID TYPE TEST REPORTS, TO BE CHECKED DURING ACCEPTANCE TESTS.

- NOTES : -
- 1) DEGREE OF PROTECTION IP 55
 - 2) THE SECONDARY TERMINAL BOX IS HOT DIP GALVANISED
 - 3) D3 TERMINAL IS FOR THE MEASUREMENT OF POWER FACTOR AND LOSS ANGLE
 - 4) THE BOX IS SUITABLE FOR ACCOMMODATING SECONDARY CABLES OF 1100 V
 - 5) STEEL SHEET 3.15 mm THICK HOT ROLLED
 - 6) ALL DIMENSIONS ARE IN mm. GENERAL TOLERANCE AS PER ISO: 2768-c
 - 7) NO. OF WIRES SHOWN IN THE TERMINAL BLOCK ARE INDICATIVE ONLY

(2) D3=Tan δ measuring terminal

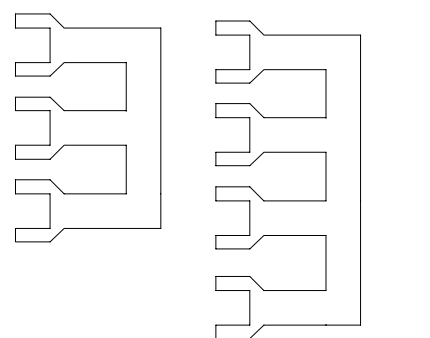

S-Shorting link

Chief Engineer/Construction

Drawing approval subject to valid vendor registration

5	COPPER WIRE
4	SERIES TERMINAL STUD TYPE
3	EPDM GASKET
2	UNDRILLED GLAND PLATE (3mm Thk.)
1	COVER
SR NO.	ITEM DESCRIPTION

Revision		CURRENT TRANSFORMER TYPE : IMB 245 SEC. TERMINAL BOX : DETAILS	DRAWN: SR	CHECKED: PDS	APPRD: SN	file: 3320-050	TOTAL SH. 1
A	2021-01-13		ABB APPSIL			1HYT903320-050	Sh. NO.
B	2021-01-21						1

NOTE : DRAWING APPROVAL SUBJECT TO VALID TYPE TEST REPORTS, TO BE CHECKED DURING ACCEPTANCE TESTS.

Annexure-A
GUARANTEED TECHNICAL PARTICULARS FOR
CURRENT TRANSFORMERS (245kV CT: 600 / 1 A)

1	Type of tank/Installation Dead/Live Tank Type	Dead tank, Single phase, Oil Filled, Outdoor Type
2	Type of mounting	Pedestal Mounting
3	Manufacturer's Name and address and Country of Manufacture	APPSIL (Formerly - ABB India Ltd) Maneja, Vadodara – 390013 India
4	Whether Conforming to IEC 61869 standard	Yes
5 a) i)	Primary and Secondary winding made out of	Primary – Aluminum, Secondary – Copper
ii)	Primary windings -Design density for short circuit current -Conductivity of metal used -	Aluminum - 44.64 Amp/mm ² (approx.) - As per IEC
b)	i) Area of cross section of primary winding	896 mm ² (approx.)
	ii) Area of cross section of secondary winding	Metering : 0.82 mm ² (approx.)
c)	Material used for providing secondary terminals	Brass (Primary Terminal will be Al)
d)	Material used for providing secondary terminals	Brass
e)	Whether Primary is Rigid Bar type in case of live tank	Not applicable
6	Rated primary voltage (kV rms)	220 KV / root3
7	Rated highest voltage (kV rms)	245 KV
8	Rated frequency (Hz)	50 Hz
9	Rated primary current (A)	600 A
10	Rated secondary current (A)	1
11	Ratio taps (on secondary side only)	On Secondary Side
12	Type of insulation	Class A
13	Seismic acceleration (g)	0.3 g vertical
14	RIV at 1.1 x Rated voltage (mv)	< 500 micro volts
15	Tank material and Tank coating	Mild Steel, HDG
16	Hardware exposed to atmosphere	HDG
17	Bolts, Nuts and Washers	MS Hot dip galvanized.
18	Porcelain housing and it make (Single piece only)	Hollow type, IEC/BHEL/ABIL/ADI/Modern or Equivalent Make
19	Sealing (Nitrogen gas cushion/Metal bellow)	Nitrogen cushion
20	Instrument security factor	<5 (For Metering core only)
21	Whether Tan Delta test tap provided	Yes
22	Whether secondary terminal plate is of molded epoxy resin type	Yes
23	Whether primary terminal bushings are of molded Epoxy cast resin/Glass fiber reinforced Polymer	Molded cast resin & Porcelain

Drawing approval subject to valid vendor registration

Chief Engineer/Construction

NOTE : DRAWING APPROVAL SUBJECT TO VALID TYPE TEST REPORTS, TO BE CHECKED DURING ACCEPTANCE TESTS.

24	Whether all seals are of "O" ring type	Yes "O" ring & Flat gasket				
25	Whether all "O" Rings are fixed in machined grooves with adequate space for compression'	Yes				
26	Whether the main hollow insulator has the flanges cemented at both ends	Yes				
27	Whether "O" Rings are of Nitrile butyl rubber or Viton	Yes (NBR)				
28	Whether the Short circuit Ampere-turns of the CT being supplied is same as type tested CTs	Yes				
29	Tan Delta	Shall be less than 0.350%				
30	Whether ratio selection is achieved only in secondary	Yes				
31	Whether ratio selection is achieved only in secondary	Yes				
32	Whether Non return drain valve for oil sampling is arranged for 132kV and above CT/IVT	Bolt Type				
33	Acceptable limit of temperature	As per IS/IEC				
34	Partial Discharge Level	< 5 at $U_m \times 1.2/\sqrt{3}$, < 10 at U_m (where U_m is highest system voltage)				
35	Rated short time withstand current for 1 sec. duration (kA rms)	40 kA				
36	Rated dynamic withstand current (kAp)	100 kA				
37	Rated continuous thermal current (pu) where pu = rated current	120% of rated primary current				
38	1.2/50 micro second impulse withstand voltage (kVp)	1050				
39	One minute power frequency withstand voltage (kV rms) of primary winding (Dry)	460				
40	One minute power frequency withstand voltage of secondary winding (kV rms)	3				
41. a)	Minimum total creepage distance of insulator bushing (mm)	6125 mm (25mm/kV) Porcelain Insulator				
b)	Protected creepage of distance of bushing (mm)	Not Applicable				
42	Details of Cores	Core-I	Core-II	Core-III	Core-IV	Core-V
42.1	Current Ratios A/A	600				
42.2	Output burden (VA)	5				
42.3	Class of accuracy	0.2S				
42.4	Accuracy limit factor / ISF	<5				
42.5	Min. knee point voltage (kpv) in volts	-				
42.6	Secondary resistance corrected to 75 deg.C in ohms	-				

Drawing approval subject to valid vendor registration

Chief Engineer/Construction

42.7	Max. Exciting current (mA) at - 20% of knee point voltage - 50% of knee point voltage - 100% of knee point voltage	- - -				
42.8	Application	Metering				
43	Weight of oil (Kg.)	140 Kg (approx.)				
44	Approximate weight of Copper used (Kgs)	2.5 Kg.				
45	Approximate weight of Steel used (Kgs)	130 kg.				
46	Total Weight (Kg.)	1050 kG. (approx.)				
47	Mounting details	450x450 (Please refer GA enclosed)				
48	Overall dimensions	Please refer GA drawing enclosed				
49	Characteristics (whether graphs enclosed):					
a)	Ratio and phase angle curves	Yes				
b)	Magnetization curves	Yes				
c)	Ratio correction factor curves	NA				
50	Core					
a)	Area of cross section (sq.cm.)	NA				
b)	Flux density at rated primary current and rated burden	As per Standard design practice				
c)	Grade	Nano Core For Metering Core				

Chief Engineer/Construction

NOTE : DRAWING APPROVAL SUBJECT TO VALID TYPE TEST REPORTS, TO BE CHECKED DURING ACCEPTANCE TESTS.

Drawing approval subject to valid vendor registration