

245 KV CURRENT TRANSFORMER TYPE: IMB 245

CLIENT:
(AS APPLICABLE)

END CUSTOMER: Drawing approval subject to valid vendor registration
APTRANSCO

W.O. NO.:
(AS APPLICABLE)

PROJECT:
(AS APPLICABLE)

P.O. NO.:
(AS APPLICABLE)

QTY.:
(AS APPLICABLE)

CT RATIO:
1600-1200-800/1-1-1-1-1

SR. NO.	REFERENCE OF STD DRGS/ DOCUMENTS	REV.	DESCRIPTION
1.	1HYT903320-035	A	GENERAL ARRANGEMENT
2.	1HYT903320-036	B	RATING PLATE
3.	1HYT903320-037	B	SECONDARY TERMINAL BOX
4.	1HYT903320-038	A	MAGNETIZATION CURVE

Chief Engineer/Construction

NOTE : DRAWING APPROVAL SUBJECT TO VALID TYPE TEST REPORTS, TO BE CHECKED DURING ACCEPTANCE TESTS.

Prepared: SR	Checked: PDS	Approved: SN
Without Sep. PL.: <input type="checkbox"/>	Same PL. Same No.: <input type="checkbox"/>	Sep. PL. Other No.: <input type="checkbox"/>
Derived by:	Supersedes:	Supersedes by:
A 2021-01-12		
B 2021-01-29		

LIST OF DOCUMENTS FOR
IMB 145
TYPE CT

Scale NTS
T.Sh. 1



1HYT903320-034

Sheets
1

We reserve all rights in this document and in the information contained there in. Reproduction, use or disclosure to third parties without express authority is strictly forbidden ©ABB.

Ⓐ New drg. prepared.

Ⓑ Change in sr no. 1,3

This drawing is a COMPUTER ORIGINAL and does not require signature for its authentication

NOTE : DRAWING APPROVAL SUBJECT TO VALID TYPE TEST REPORTS, TO BE CHECKED DURING ACCEPTANCE TESTS.

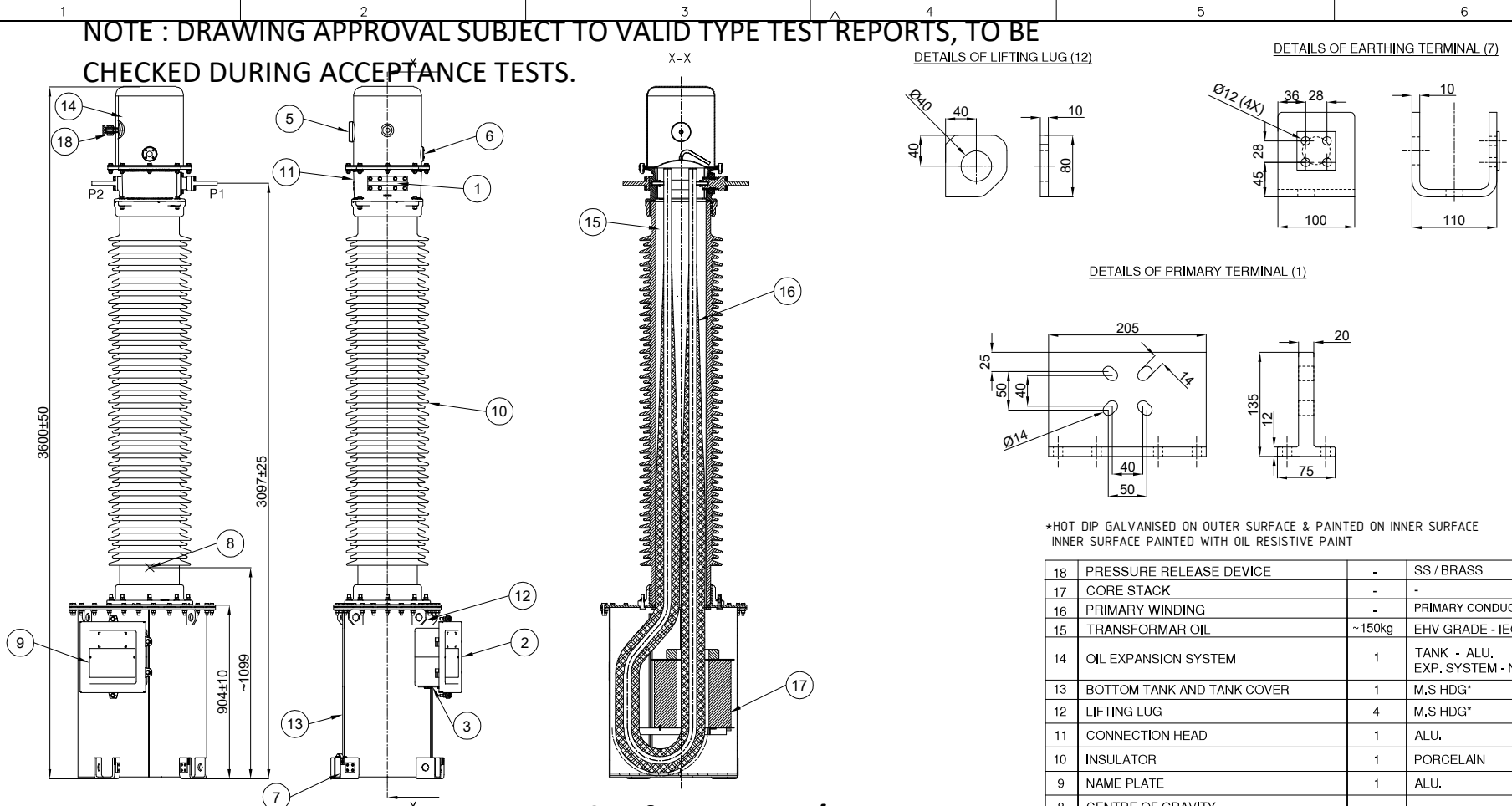

*HOT DIP GALVANISED ON OUTER SURFACE & PAINTED ON INNER SURFACE
INNER SURFACE PAINTED WITH OIL RESISTIVE PAINT

18	PRESSURE RELEASE DEVICE	-	SS / BRASS
17	CORE STACK	-	-
16	PRIMARY WINDING	-	PRIMARY CONDUCTOR (ALU)
15	TRANSFORMER OIL	~ 150kg	EHV GRADE - IEC:60296
14	OIL EXPANSION SYSTEM	1	TANK - ALU, EXP. SYSTEM - N2 GAS,
13	BOTTOM TANK AND TANK COVER	1	M,S HDG*
12	LIFTING LUG	4	M,S HDG*
11	CONNECTION HEAD	1	ALU.
10	INSULATOR	1	PORCELAIN
9	NAME PLATE	1	ALU.
8	CENTRE OF GRAVITY	-	-
7	EARTH CLAMP	4	S.S. WELDED OVER M.S.
6	OIL LEVEL INDICATOR	1	TOUGHENED GLASS
5	OIL FILLING COVER	1	ALU.
4	OIL DRAIN PLUG WITH BLANKING PLATE	1	M,S HDG*
3	REMOVABLE UNDRILLED GLAND PLATE	1	M,S HDG*
2	SECONDARY TERMINAL BOX	1	M,S HDG*
1	PRIMARY TERMINAL	2	ALU.
Sr. No.	Item Description	Qty.	Material

Chief Engineer/Construction

NOTES:

- 1) DEVIATION FOR DIMENSIONS WITHOUT SPECIFIED TOLERANCES AS PER IS: 2102 - (EXTRA COARSE).
- 2) ALL NUTS, BOLTS AND WASHERS ARE OF STAINLESS STEEL/ MS HOT DIP GALVANIZED
- 3) ALL DIMENSIONS ARE IN mm.
- 4) TOTAL WEIGHT 1150 kg approx.
- 5) CREEPAGE DISTANCE 6125 mm.
- 6) ALL FERROUS PARTS EXPOSED TO ATMOSPHERE ARE HOT DIP GALVANIZED.
- 7) GENERAL TOLERANCE AS PER IS:2768-C

Drawing approval subject to valid vendor registration

This document is COMPUTER ORIGINAL and does not need signature for its authentication

Revision Details:
(A) New drg. prepared.

We reserve all rights in this document and in the information contained therein. Reproduction, use or disclosure to third parties without express authority is strictly forbidden. © ABB

Revision	
A	2021-01-12

245 kV OUTDOOR CURRENT TRANSFORMER TYPE IMB 245

GENERAL ARRANGEMENT DRAWING (Medium Tank)

Prepared: SR
Checked: SNP
Approved: SN

file: 3320-035

Total sh. 1
Sh.No. 1

ABB APPSIL

1HYT903320-035

1

2

3

4

5

6

This drawing is a COMPUTER ORIGINAL and does not require signatures for its authentication

Revision Details:
 (B) Typo error in aux. reactor note corrected.
 Accuracy class revised to 0.2S

Revision Details:
 (A) New drg prepared.

We reserve all rights in this document and in the information contained there in. Reproduction, use or disclosure to third parties without express authority is strictly forbidden. © ABB.

ABB Current transformer APPSIL Production year - YYYY Made in India

Serial number	nnnnnn	Type	IMB 245	Frequency	50 Hz
Insulation level	245/460/1050	Standard	IEC: 61869-1,2	Temperature range	-5 to +50 °C
Rated pri. normal current	1600A	Total mass(Approx)	1150 kg	Total creepage minimum	6125mm
Max continous primary current	1920A	Insulation oil(Approx)	150 kg	Ith	40/1 kA/s
GA Drawing	1HYT903320-035	Suitable for Hot line washing	Yes	Idyn	100 kAp

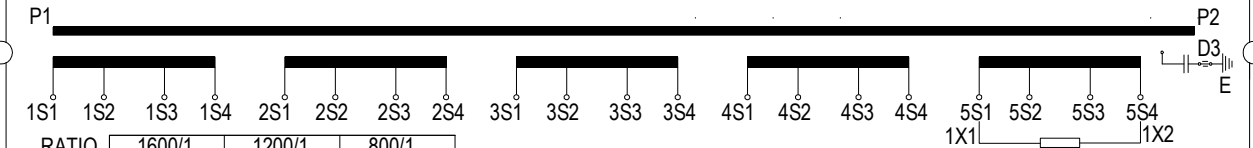

RATIO	1600/1	1200/1	800/1		
CORE-1	1S1-1S4	1S1-1S3	1S1-1S2	AUX. REACTOR CONNECTION DETAIL FOR CORE 5 ONLY 1.CONNECT SHORTING LINK BETWEEN 1X1-5S1 & 1X2-5S4 FOR THE RATIO OF 1600/1 RESPECTIVELY. TAKE OUTPUT FROM 1X1-1X2. 2.DO NOT CONNECT SHORTING LINK FOR THE RATIO OF 1200/1 & 800/1.	
CORE-2	2S1-2S4	2S1-2S3	2S1-2S2		
CORE-3	3S1-3S4	3S1-3S3	3S1-3S2		
CORE-4	4S1-4S4	4S1-4S3	4S1-4S2		
CORE-5	5S1-5S4	5S1-5S3	5S1-5S2		
CORE	CORE-1	CORE-2	CORE-3	CORE-4	CORE-5
I A	1600-1200-800/1	1600-1200-800/1	1600-1200-800/1	1600-1200-800/1	1600-1200-800/1
Vk V/B VA	>1600/1200/800	>1600/1200/800	>1600/1200/800	>1600/1200/800	20
CI	PX	PX	PX	PX	0.2S
ISF/ALF	-	-	-	-	<5
Io mA	<15/20/30 at Vk	<15/20/30 at Vk	<15/20/30 at Vk	<15/20/30 at Vk	-
Rct Ω	<8/6/4	<8/6/4	<8/6/4	<8/6/4	-

END CUSTOMER: APTRANSCO
 ABB WORKS ORDER NO: (AS APPLICABLE)
 PROJECT: (AS APPLICABLE)

Caution 1)Ensure D3(Tan Delta) Bushing connection with Earth
 2)Secondary terminals must be short circuited before burden is disconnected

Serial number nnnnnn to be decided when manufactured
 Production year yyyy = Actual year,date & month of Production
 Material: Aluminium 2mm Thk.
 Letter height 3 mm

Drawing approval subject to valid vendor registration

NOTE : DRAWING APPROVAL SUBJECT TO VALID TYPE TEST REPORTS, TO BE CHECKED DURING ACCEPTANCE TESTS.

Chief Engineer/Construction

Revision		245 kV OUTDOOR CURRENT TRANSFORMER TYPE IMB 245	RATING PLATE	Prepared: SR	Checked: PDS	Approved: SN	File: 3320-036	Total sh. 1
A	2021-01-12			ABB APPSIL			1HYT903320-036	Sh.No. 1
B	2021-01-29							1

NOTE : DRAWING APPROVAL SUBJECT TO VALID TYPE TEST REPORTS, TO BE CHECKED DURING ACCEPTANCE TESTS.

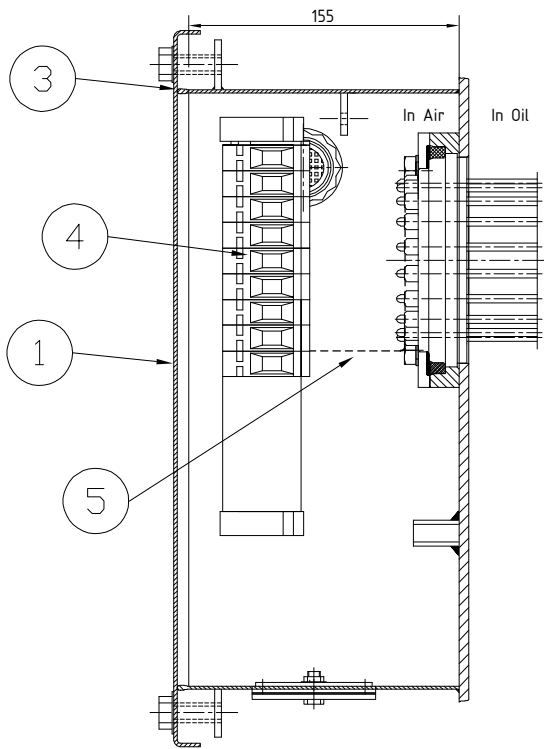

Section-AA

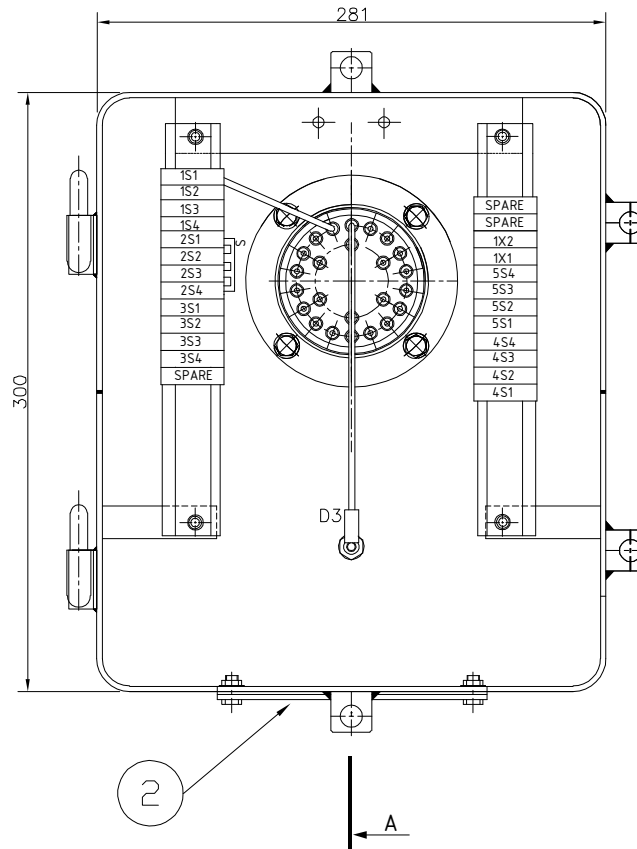

D3=Tan δ measuring terminal

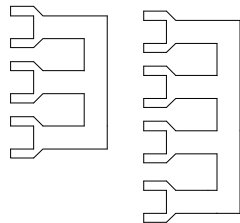

S-Shorting link

AUX. REACTOR CONNECTION WITH CORE 5 (METERING)

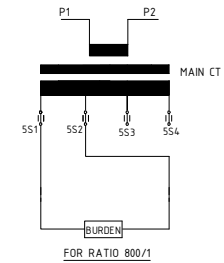
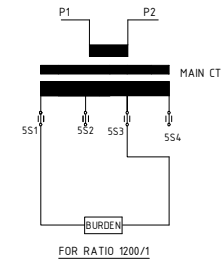
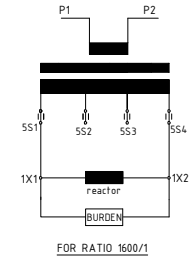

Drawing approval subject to valid vendor registration

NOTES : -

- 1) DEGREE OF PROTECTION IP 55
- 2) THE SECONDARY TERMINAL BOX IS HOT DIP GALVANISED
- 3) D3 TERMINAL IS FOR THE MEASUREMENT OF POWER FACTOR AND LOSS ANGLE
- 4) THE BOX IS SUITABLE FOR ACCOMMODATING SECONDARY CABLES OF 1100 V
- 5) STEEL SHEET 3.15 mm THICK HOT ROLLED
- 6) ALL DIMENSIONS ARE IN mm. GENERAL TOLERANCE AS PER ISO: 2768-c
- 7) NO. OF WIRES SHOWN IN THE TERMINAL BLOCK ARE INDICATIVE ONLY

5	COPPER WIRE
4	SERIES TERMINAL STUD TYPE
3	EPDM GASKET
2	UNDRILLED GLAND PLATE (3mm Thk.)
1	COVER
SR NO.	ITEM DESCRIPTION

Chief Engineer/Construction

We reserve all rights in this document and in the information contained there in. Reproduction or disclosure to third parties without express authority is strictly forbidden. @ABB.

Revision Details:
 (B) Gland plate thickness added BOTH created

Revision Details:
 (A) New Drawing prepared

Revision		
A	2021-01-13	
B	2021-01-21	

CURRENT TRANSFORMER
 TYPE : IMB 245
 SEC. TERMINAL BOX : DETAILS

DRAWN:
 SR
ABB APPSIL

CHECKED:
 PDS

APPRD.:
 SN

file: 3320-037

1HYT903320-037

TOTAL SH.
 1
 Sh. NO.
 1

Item	Core	Current Ratio	Sec. Resistance At 75° C. Ohms	C1	C2
10	1,2,3,4	1600/1	<8	16.49	0.048
		1200/1	<6	12.37	0.064
		800/1	<4	8.24	0.096

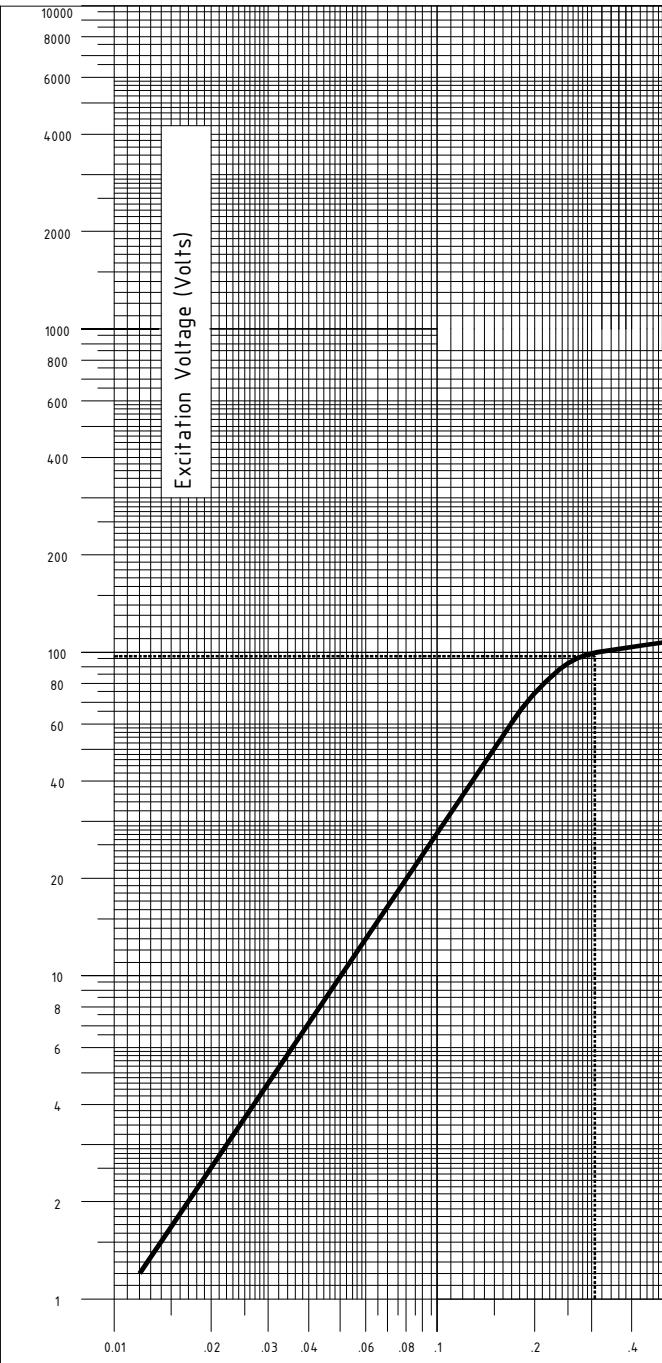

Notes:

1. The exciting current calculated from this graph does not take into account the current drawn by the protective device.
2. The values on the Voltage scale are to be multiplied by C1, while those on the current scale by C2.

Calculated Excitation Curve of Current Transformer Type: **IMB245**

CORE 1,2,3,4 RATIO: 1600-1200-800/1, CLASS OF ACCURACY: PX
 Vk >1600/1200/800 V, Rct < 8/6/4 Ohms, Io < 15/20/30mA at Vk

(A) New drg. prepared.

Drawing approval subject to valid vendor registration

Chief Engineer/Construction

NOTE : DRAWING APPROVAL SUBJECT TO VALID TYPE TEST REPORTS, TO BE CHECKED DURING ACCEPTANCE TESTS.

This document is COMPUTER ORIGINAL and does not need signature for its authentication

Drn: SR Chkd: PDS Apprd: SN



filename: 3320-038

1HYT903320-038

NOTE : DRAWING APPROVAL SUBJECT TO VALID TYPE TEST REPORTS, TO BE CHECKED DURING ACCEPTANCE TESTS.

Annexure-A
GUARANTEED TECHNICAL PARTICULARS FOR
CURRENT TRANSFORMERS (245kV CT: 1600-1200-800/1-1-1-1 A)

1	Type of tank/Installation Dead/Live Tank Type	Dead tank, Single phase, Oil Filled, Outdoor Type
2	Type of mounting	Pedestal Mounting
3	Manufacturer's Name and address and Country of Manufacture	APPSIL (Formerly - ABB India Ltd) Maneja, Vadodara – 390013 India
4	Whether Conforming to IEC 61869 standard	Yes
5 a) i)	Primary and Secondary winding made out of	Primary – Aluminum, Secondary – Copper
ii)	Primary windings -Design density for short circuit current - Conductivity of metal used -	Aluminum - 19.37 Amp/mm ² (approx.) - As per IEC
b)	i) Area of cross section of primary winding	2065 mm ² (approx.)
	ii) Area of cross section of secondary winding	PX : 1.17 mm ² (approx.) Metering : 0.82 mm ² (approx.)
c)	Material used for providing secondary terminals	Brass (Primary Terminal will be Al)
d)	Material used for providing secondary terminals	Brass
e)	Whether Primary is Rigid Bar type in case of live tank	Not applicable Drawing approval subject to valid vendor registration
6	Rated primary voltage (kV rms)	220 KV / root3
7	Rated highest voltage (kV rms)	245 KV
8	Rated frequency (Hz)	50 Hz
9	Rated primary current (A)	1600-1200-800 A
10	Rated secondary current (A)	1
11	Ratio taps (on secondary side only)	On Secondary Side
12	Type of insulation	Class A
13	Seismic acceleration (g)	0.3 g vertical
14	RIV at 1.1 x Rated voltage (mv)	< 500 micro volts
15	Tank material and Tank coating	Mild Steel, HDG
16	Hardware exposed to atmosphere	HDG
17	Bolts, Nuts and Washers	MS Hot dip galvanized.
18	Porcelain housing and it make (Single piece only)	Hollow type, IEC/BHEL/ABIL/ADI/Modern or Equivalent Make
19	Sealing (Nitrogen gas cushion/Metal bellow)	Nitrogen cushion
20	Instrument security factor	<5 (For Metering core only)
21	Whether Tan Delta test tap provided	Yes
22	Whether secondary terminal plate is of molded epoxy resin type	Yes
23	Whether primary terminal	Molded cast resin & Porcelain

Chief Engineer/Construction

NOTE : DRAWING APPROVAL SUBJECT TO VALID TYPE TEST REPORTS, TO BE CHECKED DURING ACCEPTANCE TESTS.

	bushings are of molded Epoxy cast resin/Glass fiber reinforced Polymer					
24	Whether all seals are of "O" ring type	Yes "O" ring & Flat gasket				
25	Whether all "O" Rings are fixed in machined grooves with adequate space for compression'	Yes				
26	Whether the main hollow insulator has the flanges cemented at both ends	Yes				
27	Whether "O" Rings are of Nitrile butyl rubber or Viton	Yes (NBR)				
28	Whether the Short circuit Ampere-turns of the CT being supplied is same as type tested CTs	Yes	Drawing approval subject to valid vendor registration			
29	Tan Delta	Shall be less than 0.350%				
30	Whether ratio selection is achieved only in secondary	Yes				
31	Whether ratio selection is achieved only in secondary	Yes				
32	Whether Non return drain valve for oil sampling is arranged for 132kV and above CT/IVT	Bolt Type				
33	Acceptable limit of temperature	As per IS/IEC				
34	Partial Discharge Level	< 5 at $U_m \times 1.2/\sqrt{3}$, < 10 at U_m (where U_m is highest system voltage)				
35	Rated short time withstand current for 1 sec. duration (kA rms)	40 kA				
36	Rated dynamic withstand current (kAp)	100 kA				
37	Rated continuous thermal current (pu) where pu = rated current	120% of rated primary current				
38	1.2/50 micro second impulse withstand voltage (kVp)	1050				
39	One minute power frequency withstand voltage (kV rms) of primary winding (Dry)	460				
40	One minute power frequency withstand voltage of secondary winding (kV rms)	3				
41. a)	Minimum total creepage distance of insulator bushing (mm)	6125 mm (25mm/kV) Porcelain Insulator				
b)	Protected creepage of distance of bushing (mm)	Not Applicable				
42	Details of Cores	Core-I	Core-II	Core-III	Core-IV	Core-V
42.1	Current Ratios A/A	1600-1200-800 /1	1600-1200-800 /1	1600-1200-800 /1	1600-1200-800 /1	1600-1200-800 /1
42.2	Output burden (VA)	-	-	-	-	20

Chief Engineer/Construction

42.3	Class of accuracy	PX	PX	PX	PX	0.2S
42.4	Accuracy limit factor / ISF	-	-	-	-	<5
42.5	Min. knee point voltage (kpv) in volts	>1600-1200-800	>1600-1200-800	>1600-1200-800	>1600-1200-800	-
42.6	Secondary resistance corrected to 75 deg.C in ohms	8-6-4@ Ohms	8-6-4@ Ohms	8-6-4@ Ohms	8-6-4@ Ohms	-
42.7	Max. Exciting current (mA) at - 20% of knee point voltage - 50% of knee point voltage - 100% of knee point voltage	- - 15-20-30	- - 15-20-30	- - 15-20-30	- - 15-20-30	- - -
42.8	Application	PX	PX	PX	PX	Metr.
43	Weight of oil (Kg.)	150 Kg (approx.)				
44	Approximate weight of Copper used (Kgs)	27 Kg.				
45	Approximate weight of Steel used (Kgs)	220 kg.				
46	Total Weight (Kg.)	1150 kg (approx.)				
47	Mounting details	450x450 (Please refer GA enclosed)				
48	Overall dimensions	Please refer GA drawing enclosed				
49	Characteristics (whether graphs enclosed):					
a)	Ratio and phase angle curves	Yes				
b)	Magnetization curves	Yes				
c)	Ratio correction factor curves	NA				
50	Core					
a)	Area of cross section (sq.cm.)	37.12 sq. cm. (PX Core)				
b)	Flux density at rated primary current and rated burden	As per Standard design practice				
c)	Grade	M4 (Or equivalent) For PX Core Nano Core For Metering Core				

Chief Engineer/Construction

NOTE : DRAWING APPROVAL SUBJECT TO VALID TYPE TEST REPORTS, TO BE CHECKED DURING ACCEPTANCE TESTS.

Drawing approval subject to valid vendor registration