

NOTE: 1. DRAWING APPROVAL SUBJECT TO VALID TYPE TEST REPORTS, TO BE CHECKED DURING ACCEPTANCE TESTS
2. FOR EPC CONTRACTS ONLY

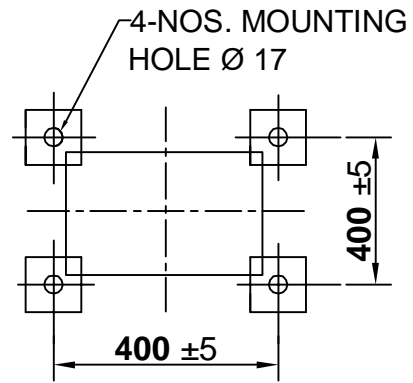
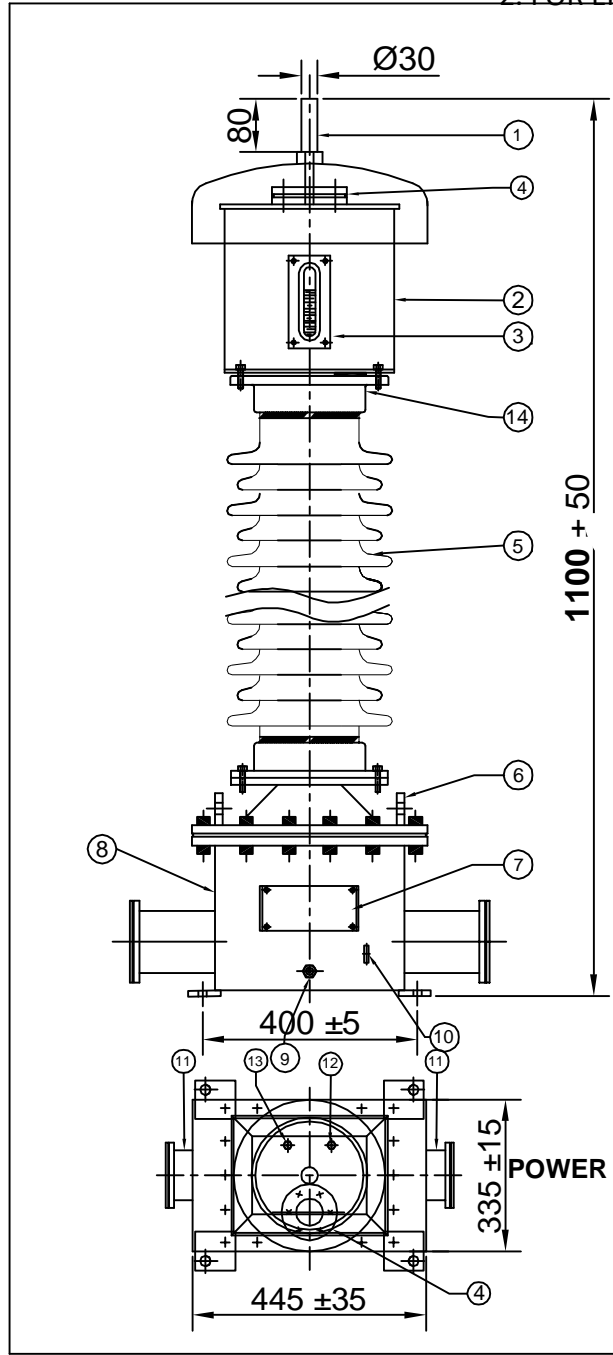

MOUNTING DETAILS

S.No.	DESCRIPTION	QTY	MATL
1	H.T TERMINAL		NICKLE PLATED COPPER
2	OIL EXPANSION CHAMBER	1	M.S
3	OIL LEVEL INDICATOR	1	Al+Glass
4	PRESSURE RELEASE DEVICE	1	AL+Bakelite
5	BUSHING	1	PORCELAIN
6	LIFTING PLUG	2	M.S
7	NAME AND RATING PLATE	1	AL.Anodised
8	TANK WITH COVER	1	M.S
9	OIL DRAIN PLUG	1	M.S
10	EARTHING FLAT 80x50x8mm THICK	2	M.S
11	SECONDARY TERMINAL BOX	2	M.S
12	NITROGEN VALVE	1	BRASS
13	OIL FILLING PLUG	1	M.S
14	BUSHING CLAMP (CEMENTED)	2	GI/CI

NOTES:

- 1. ALL FERROUS PARTS EXPOSED TO THE ATMOSPHERE SHALL BE PAINTED WITH P.U PAINT SHADE 631 OF IS: 5.
- 2. MAKE OF BUSHING: IEC/MODERN/BHEL/ABIL/CJI/GENESIS
- 3. TOTAL CREEPAGE DISTANCE :- 1116 mm (Min.)
- 4. QUANTITY OF OIL :- 20 LITRES APPROX.
- 5. TOTAL WEIGHT OF PT : 130 KGS APPROX.
- 6. ALL HARDWARE SHALL BE HOT DIP GALVANIZED.
- 7. TRANSFORMER OIL AS PER IEC : 60296.
- 8. ALL GASKETS SHALL BE FIXED IN PROPERLY MACHINED GROOVES.
- 9. ALL GASKETS SHALL BE MADE OF NITRILE BUTYL RUBBER.

**CHIEF ENGINEER
POWER SYSTEMS, PLANNING & DESIGN
APTRANSCO**

REV.	REVISION DESCRIPTION	DATED INITIALS
R0	FOR APPROVAL	06.01.2021

CLIENT : TRANSMISSION CORPORATION OF ANDHRA PRADESH LIMITED				PROJECT NAME : AS APPLICABLE	
UNLESS OTHERWISE SPECIFIED		DATE	NAME	MATERIAL	<div style="border: 1px solid black; padding: 2px; display: inline-block;">MEHRU</div> MEHRU ELECTRICAL & MECHANICAL ENGINEERS (P) LTD.
DGN.	06.01.2021	SPS	AS ABOVE		
DRN.	06.01.2021	AKASH			
CHD.	06.01.2021	BLS			
SCALE:	N.T.S				
TITLE :					
GENERAL ARRANGEMENT DRAWING FOR 33KV POTENTIAL TRANSFORMER					
SHEET No. 1 OF 5					DRG.NO ME-33PT-GA-01

MEHRU VOLTAGE TRANSFORMER

SR.No.		REF.STD.	IS: 16227
TYPE	Outdoor Oil Cooled	RATIO	33 kV / $\sqrt{3}$
Highest System Voltage	36 kV		110V/ $\sqrt{3}$ - 110V/ $\sqrt{3}$
PHASE	Single	BURDEN	50 VA - 10 VA
Insulation level	70/170 kV	CLASS	0.2 - 0.2
Thermal Burden	60 VA	Simultaneous Burden	50 VA - 10 VA
Frequency	50 Hz	Type	Earthed
Voltage Factor	1.2	TIME CONT. &	1.5
		TIME FOR	30 Sec
		YEAR OF MFG.	2021

TOTAL WEIGHT OF VT : 130 KGS APPROX.
 QUANTITY OF OIL :- 20 LITRES APPROX. TOTAL CREEPAGE DISTANCE :- 1116 mm (Min.)

MADE IN INDIA BY
MEHRU ELECTRICAL AND MECHANICAL ENGINEERS (P) LTD.
 E-1247 RIICO INDUSTRIAL AREA , PHASE I , EXT GHATAL , BHIWADI-301 019

SUITABLE FOR HOT LINE WASHING CONNECTION DIAGRAM

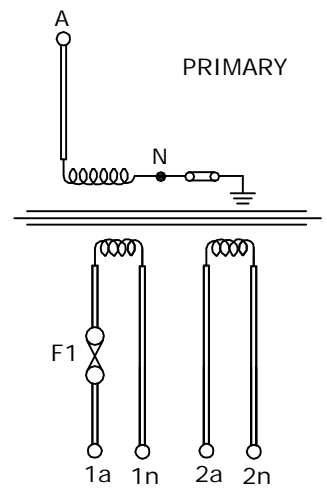

CAUTION :
 1. DO NOT REMOVE EARTH LINK WHEN IN OPERATION.

115 ±10

195 ±15

NOTES: -

1. THICKNESS OF RATING PLATE 1.2 mm
2. MATERIAL OF NAME PLATE SHALL BE AL. ANODIZED.
3. SERIAL NUMBER SHALL BE ENGRAVING BEFORE THE DISPATCH.

- NOTE: 1. DRAWING APPROVAL SUBJECT TO VALID TYPE TEST REPORTS, TO BE CHECKED DURING ACCEPTANCE TESTS**
2. FOR EPC CONTRACTS ONLY

**CHIEF ENGINEER
 POWER SYSTEMS, PLANNING & DESIGN
 APTRANSCO**

RO	FOR APPROVAL	06.01.2021
REV.	REVISION DESCRIPTION	DATED INITIALS

CLIENT : TRANSMISSION CORPORATION OF ANDHRA PRADESH LIMITED				PROJECT NAME : AS APPLICABLE	
UNLESS OTHERWISE SPECIFIED 1. ALL DIMENSIONS ARE IN mm. 2. TOLERANCE WHEREVER NOT INDICATED ±5%	DGN.	06.01.2021	SPS	MATERIAL AL.ANODIZED	 MEHRU ELECTRICAL & MECHANICAL ENGINEERS (P) LTD.
	DRN.	06.01.2021	AKASH		
	CHD.	06.01.2021	BLS		
	SCALE:	N.T.S			
TITLE :			NAME PLATE DRAWING FOR 33KV POTENTIAL TRANSFORMER		
SHEET No.			3 OF 5		
DRG.NO			ME-33PT-NP-01		

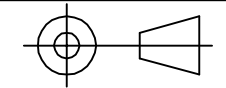

NOTE: 1. DRAWING APPROVAL SUBJECT TO VALID TYPE TEST REPORTS, TO BE CHECKED DURING ACCEPTANCE TESTS
 2. FOR EPC CONTRACTS ONLY

S.No.	DESCRIPTION	QTY	MATL
1	H.T TERMINAL		NICKLE PLATED COPPER
2	OIL EXPANSION CHAMBER	1	M.S
3	OIL LEVEL INDICATOR	1	Al-Glass
4	L.T COIL WITH PAPER INSULATION	1	CU./PAPER
5	BUSHING	1	PORCELAIN
6	LIFTING PLUG	2	M.S
7	NAME AND RATING PLATE	1	AL,Anodised
8	TANK WITH COVER	1	M.S
9	OIL DRAIN PLUG	1	M.S
10	EARTHING FLAT 80x50x8mm THICK.	2	M.S
11	SECONDARY TERMINAL BOX	2	M.S
12	NITROGEN VALVE	1	BRASS
13	OIL FILLING PLUG	1	M.S
14	H.T COIL WITH PAPER INSULATION	1	CU./PAPER
15	PRESSURE RELEASE DEVICE	1	ALU.+Bakelite
16	BUSHING GASKET	2	N.B.R
17	STACK LAMINATION	1	CRGO
18	BUSHING CLAMP (CEMENTED)	2	GI/CI

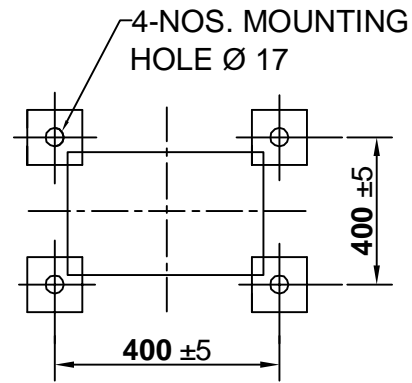
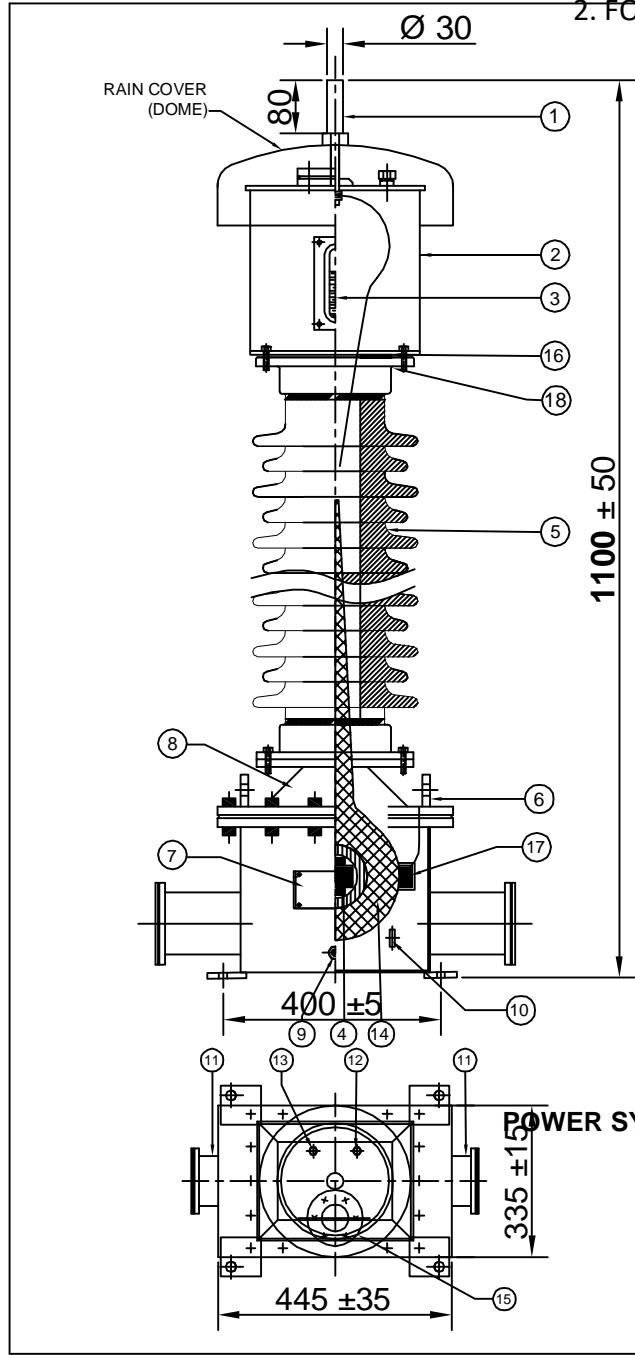

MOUNTING DETAILS

NOTES :

1. ALL FERROUS PARTS EXPOSED TO THE ATMOSPHERE SHALL BE PAINTED WITH P.U PAINT SHADE 631 OF IS: 5.
2. MAKE OF BUSHING: IEC/MODERN/BHEL/ABIL/CJI/GENESIS
3. TOTAL CREEPAGE DISTANCE :- 1116 mm (Min.)
4. QUANTITY OF OIL :- 20 LITRES APPROX.
5. TOTAL WEIGHT OF PT : 130 KGS APPROX.
6. ALL HARDWARE SHALL BE HOT DIP GALVANIZED.
7. TRANSFORMER OIL AS PER IEC : 60296.
8. ALL GASKETS SHALL BE FIXED IN PROPERLY MACHINED GROOVES.
9. ALL GASKETS SHALL BE MADE OF NITRILE BUTYL RUBBER.

CHIEF ENGINEER
POWER SYSTEMS, PLANNING & DESIGN
APTRANSCO

REV.	REVISION DESCRIPTION	DATED INITIALS
R0	FOR APPROVAL	06.01.2021

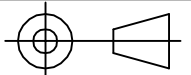
CLIENT : TRANSMISSION CORPORATION OF ANDHRA PRADESH LIMITED PROJECT NAME : AS APPLICABLE			
UNLESS OTHERWISE SPECIFIED	DATE	NAME	MATERIAL
1. ALL DIMENSIONS ARE IN mm. 2. TOLERANCE WHEREVER NOT INDICATED ±5%	DGN.	06.01.2021	SPS
	DRN.	06.01.2021	AKASH
	CHD.	06.01.2021	BLS
	SCALE:	N.T.S	
TITLE :			 MEHRU ELECTRICAL & MECHANICAL ENGINEERS (P) LTD.
SECTIONAL ARRANGEMENT DRAWING FOR 33KV POTENTIAL TRANSFORMER			
SHEET No. 2 OF 5			 DRG.NO ME-33PT-SE-01

Drawing approval subject to valid vendor registration

NOTE: 1. DRAWING APPROVAL SUBJECT TO VALID TYPE TEST REPORTS, TO BE CHECKED DURING ACCEPTANCE TESTS
2. FOR EPC CONTRACTS ONLY

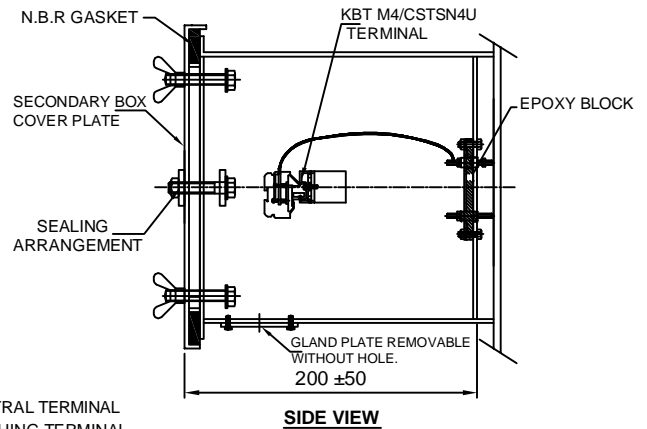
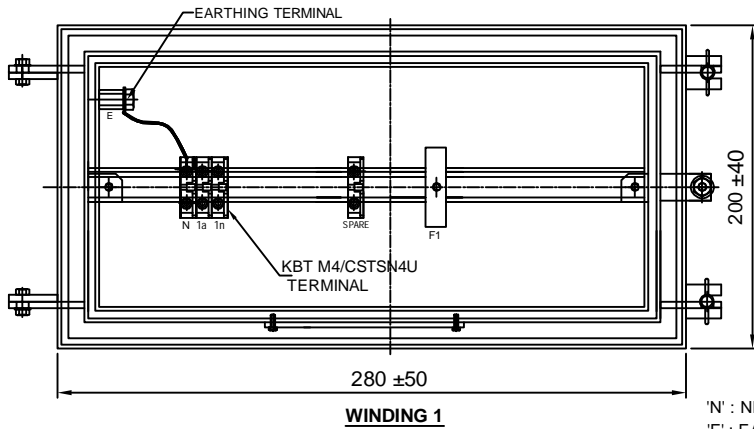
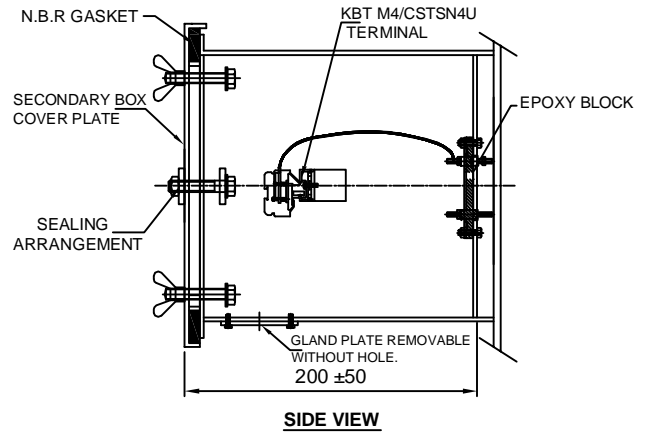
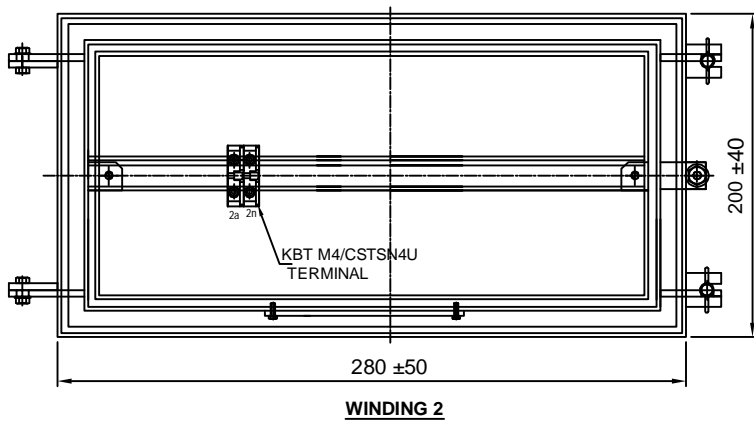

'N': NEUTRAL TERMINAL
'E': EARTHING TERMINAL
F1: FUSE 6Amp.

NOTES:-

1. SECONDARY TERMINAL BOX SHALL BE PROVIDED REMOVABLE GLAND PLATE WITHOUT HOLE.
2. SECONDARY TERMINAL BOX SHALL BE PROVIDED WITH COVER.
3. M.S SHEET THICKNESS FOR TERMINAL BOX 3.0mm. & FOR COVER 2.0mm.
4. MATERIAL OF GASKET: NITRILE BUTYL RUBBER GASKET.
5. DEGREE OF PROTECTION : IP 55
6. 20% SPARE TERMINAL SHALL BE PROVIDED.

Drawing approval subject to valid vendor registration

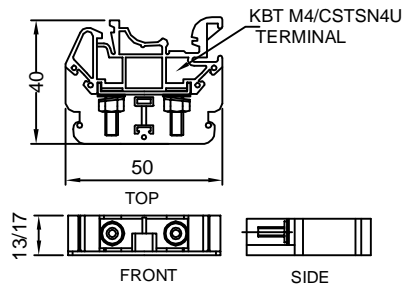

MATERIAL: POLYAMIDE
MAKE: ELMEX/CONNECTWELL

TERMINAL (DETAIL)

RO	FOR APPROVAL	06.01.2021
REV.	REVISION DESCRIPTION	DATED INITIALS

CLIENT : TRANSMISSION CORPORATION OF ANDHRA PRADESH LIMITED			
PROJECT NAME : AS APPLICABLE			
UNLESS OTHERWISE SPECIFIED	DATE	NAME	MATERIAL
1. ALL DIMENSIONS ARE IN mm. 2. TOLERANCE WHEREVER NOT INDICATED ±5%	DGN.	06.01.2021	SPS
	DRN.	06.01.2021	AKASH
	CHD.	06.01.2021	BLS
	SCALE:	N.T.S	
TITLE :			M.S
SECONDARY TERMINAL BOX DRAWING FOR 33kV POTENTIAL TRANSFORMER			
SHEET No. 4 OF 5			MEHRU MEHRU ELECTRICAL & MECHANICAL ENGINEERS (P) LTD.
			DRG. NO. ME-33PT-STB-01

4620255/2021/EEMRT-ENE51

GUARANTEE TECHNICAL PARTICULARS OF 33kV POTENTIAL TRANSFORMER		
S.NO	DESCRIPTION	33kV
1	Type Applicable Standard	IS-16227
2	Manufacturer's type designation	Outdoor, Oil Cooled, Electromagnetic Type, Voltage Transformer
3	Mounting of tank (bottom)	Bottom
4	System rated voltage/highest voltage (kv)	33/36
5	Rated primary voltage (kv)	33kV/ $\sqrt{3}$
6	Secondary winding details	
	(a)No.ofsecondary windings	2
	(b)Rated secondary voltage(V)	110 V/ $\sqrt{3}$ 110V/ $\sqrt{3}$
	©Rated burden VA (simultaneous)	50VA 10VA
	(d)Class of accuracy	Wdg:1: - 0.2 Wdg:2- 0.2

NOTE: 1. DRAWING APPROVAL SUBJECT TO VALID TYPE TEST
REPORTS, TO BE CHECKED DURING ACCEPTANCE TESTS
2. FOR EPC CONTRACTS ONLY

CHIEF ENGINEER
POWER SYSTEMS, PLANNING & DESIGN
APTRANSCO

4620255/2021/EEMRT-ENE51

7	Maximum ratio error with % rated burden and 5 % normal primary voltage	In limits as per IS 16227
8	Maximum phase angle error with % rated burden and 5 % normal primary voltage	In limits as per IS 16227
9	Temperature rise at 1.1 times rated voltage with rated burden deg.C	50deg C
10	Rated voltage factor and time	1.2 continuous & 1.5 for 30 seconds
11	Temperature rise for item-10 above deg.C	
12	Impulse withstand test voltage (kv) peak	170
13	One minute power frequency withstand test voltage on secondary (kv rms)	3
14	One minute power frequency withstand test voltage on primary (kv rms)	70
15	Total creepage distance of the bushing mm	31 mm/kV i.e. 1116 mm
16	Grade of oil	EHV IS 335/IEC 60296
17	Quantity of insulating oil (Litres)	20Ltr Approx
18	Weight of oil (kg)	16kgs Approx.
19	Total weight including oil (kg)	130kG Approx
20	Whether sealed (if so type of sealing)	PRD
21	Over all dimensions	
	Height (mm)	1100±50mm

NOTE: 1. DRAWING APPROVAL SUBJECT TO VALID TYPE TEST REPORTS, TO BE CHECKED DURING ACCEPTANCE TESTS
2. FOR EPC CONTRACTS ONLY

4620255/2021/EEMRT-ENE51

	Length (mm)	400±5mm
	Breadth (mm)	400±5mm
b)	Partial discharge level	<10 pC at Um & <5 pc at 1.2Um/√3
22	Weight of Steel	35 kgs (Approx.)
	Weight of copper	6 kgs (Approx.)

NOTE: 1. DRAWING APPROVAL SUBJECT TO VALID TYPE TEST
 REPORTS, TO BE CHECKED DURING ACCEPTANCE TESTS
 2. FOR EPC CONTRACTS ONLY

**CHIEF ENGINEER
 POWER SYSTEMS, PLANNING & DESIGN
 APTRANSCO**

Drawing approval subject to valid vendor registration