

Description		400-SFM-60AA	
Title : Guaranteed Technical Particulars		Doc.No.: S3GTP-400SP	
Equipment : SF6 Gas Circuit Breaker		Spring-Spring Type:400-SFM-60AA	
1	GENERAL	Unit	Without PIR
a)	Name of the Manufacturer		CG Power and Industrial Solutions Limited
b)	Country of Manufacture		India
c)	Type of Circuit Breaker		SF6 Gas Insulated
d)	Manufacturer's type designation		400-SFM-60AA
e)	Standard applicable		IEC-62271-100
f)	Rated Voltage	kV (rms)	420
g)	Rated Current		
i.	under normal condition at 40 degree C ambient	A	Upto 4000
ii.	under site condition at 50 degree C ambient	A	Upto 4000
h)	Rated Frequency	Hz	50
i)	Number of poles	No.	3
j)	Whether gang operated		
i.	Electrically		Yes
ii.	Mechanically		No
k)	Whether dead tank or live tank		Live tank
l)	Type of installation		Outdoor
m)	Number of breaks per pole	No	2
n)	Latching current	kAp	125
2	GUARANTEED RATINGS		
a)	Rated short circuit breaking currents		
i.	Symmetrical component at rated voltage	kA	63
ii.	DC component	%	51.34%
iii.	Asymmetrical breaking current at rated voltage	kA	77.9
b)	Rated short circuit making current OR Short circuit peak withstand current		
i.	at higher rated voltage	kA (peak)	125
ii.	at lower rated voltage	kA (peak)	125
c)	Break time		
i.	Rated Break time	ms	</=40
d)	Rated Closing time	ms	</=90
e)	Rated Opening time	ms	</=25
f)	Rated Arcing time	ms	</=20
g)	First pole to clear factor		1.3
h)	Rated Close open time	ms	</=60 ms
i)	Rated Short-time withstand current		
i.	1 second	kA	63
ii.	3 second	kA	63
j)	Rated operating duty		O-0.3s-CO-3min-CO
k)	Maximum breaking capacity under kilometric faults and rated TRV characteristics		L90 & L75 As per IEC-62271-100
l)	Rated Out of Phase Current		
i)	Rated out-of-phase breaking current OR Rated breaking capacity under asynchronous condition	kA	15.75
ii)	Rated out-of-phase Making current	kA	1.1 kA
m)	Rated line charging breaking current	A	600
n)	Rated cable charging breaking current	A	600
o)	Rated single capacitor bank breaking current	A	600
	Rated inductive current	A	
p)	Corresponding over voltage during breaking capacitive current	p.u.	< 2.3
q)	Rated shunt reactor breaking current	A	315
r)	Maximum arc duration and corresponding breaking current under lockout pressure	ms, kA	20, 50
s)	Rated Small fault current breaking capacity	kA	5
t)	Maximum temperature rise for main contacts over an ambient temperature of 50 degree C	°C	< 55 degree C
u)	Rated supply voltage and pick up range for		
i.	Trip coil	V DC	220,(70 to 110%)
ii.	Close coil	V DC	220, (85 to 110%)
v)	Normal power consumption at rated supply voltage of		
i.	Trip Coil	W	3 x 400 W at 220 VDC
ii.	Close Coil	W	3 x 400 W at 220 VDC
w)	Rated pressure and limits of operation for extinguishing medium at 20 deg.C		
i.	for operating mechanism	(kg/cm ²)	NA
ii.	for extinguishing medium	(kg/cm ²) - gauge	7; 6 to 7
x)	Minimum dead time for		
i.	Three phase reclosing	ms	300
ii.	Single phase reclosing	ms	300
y)	Data on Restriking voltage		
i.	Rated Breaking currents	%	100% 60% 30% 10%
ii.	TRV Peak	kV (peak)	624 669 687 787
iii.	Amplitude factor		1.4 1.5 1.54 1.53
iv.	First pole to clear factor		1.3 1.3 1.3 1.5

Chief Engineer/Projects
APTRANSCO/VIS/Vijayawada.

	v. Rate of rise of restriking voltage	kV/μS	2	3	5	7
	2) No. of breaker operations before maintenance					
	i. at rated interrupting capacity		10			
	ii. at 50% of rated interrupting capacity		40			
	iii. at rated normal current		1500			
	iv. at 50% of rated normal current		6000			
	aa) Maximum pole discrepancy during					
	i. Opening	ms	</=3.3			
	ii. Closing	ms	</=5			
	iii. Within pole	ms	</=2.5			
	bb) Minimum time interval between each make / break operations	ms	Suitable for Operating seq. O-0.3sec-CO-3min-CO			
	cc) Pre-Insertion Resistor					
	i. Value per pole	Ohms	400			
	ii. Insertion time	ms	8 - 12			
	iii. Thermal Rating for the duty C-1m-O-CO-2m-C-1m-O-CO for terminal fault with maximum time setting		Adequate			
	iv. Thermal Rating for the same duty as in (iii) above for reclosing against trapped charges		Adequate			
	dd) Grading Capacitor		Not required			
	i. Capacitance value	Drawing approval subject to valid vendor registration				
	ii. Overvoltage withstand capacity					
	Continuous	kV	145			
	10 minutes	kV	220			
	1 minute	kV	400			
	5 seconds	kV	440			
3	DIELECTRIC WITHSTANDS OF COMPLETE BREAKER					
	a) One minute dry and wet power withstand voltage					
	i. Between live terminal	kV (rms)	520			
	ii. Between terminal with breaker contacts open & ground	kV (rms)	610 with breaker contacts open and 520 to ground			
	b) 1.2/50 micro second impulse withstand voltage					
	i. Between live terminal	kV (peak)	+/-1425			
	ii. Between terminal with breaker contacts open & ground	kV (peak)	+/-1425 impulse on one terminal and 240kV(peak) power frequency voltage on other terminal			
	c) 250/2500 micro second switching impulse withstand voltage					
	i. Between live terminals and ground	kV (peak)	+/-1050			
	ii. Between terminals with breaker contacts open	kV (peak)	+/-900 switching impulse on one terminal and 345 kVp P.F. voltage on other terminal			
	c) Creepage distance					
	i. To earth	mm	25 mm/kv			
	ii. Across interruptor	mm	25 mm/kv			
	d) Maximum radio interference voltage at 1.1 Ur /root 3	μV	</=1000 @ 267 kV			
	e) Visible Corona discharge voltage	kV (rms)	346 kV rms min			
4	OPERATING MECHANISM					
	4.1 SPRING CHARGING MECHANISM					
	a) Type of operating mechanism		Motorised Spring charged mechanism			
	i. Closing		Spring			
	ii. Opening		Spring			
	b) Type Designation		SOM 2-5			
	c) No. of operations possible with stored energy		O-C-O			
	4.2 DETAILS OF SPRING CHARGING MOTOR					
	a) Type of Motor		Universal			
	b) Type of Mounting		Neck Mounted			
	c) Direction of rotation as viewed from non-driving end		Clockwise			
	d) Rated supply voltage and operating range	V AC	1 Ph, 240, 85-110%			
	e) Motor Wattage	W	750w input 360w output			
	f) Rated speed at rated voltage and frequency on no load	rpm	775			
	g) Full load current at rated voltage and frequency	A	6A at 240V, 50Hz AC			
	h) Efficiency of motor at rated voltage and frequency	%	50			
	i) Starting current		< 600% at full load current			
	j) Stator winding insulation class		B			
	k) Weight	kg	5.5 approx.			
	l) Maximum time for charging the spring	sec.	15			
	m) Whether indication of spring charged condition provided in control cabinet		Yes			
	n) Make of Motor		KPT/MEIWA/FAL/RALLYWF			
5	DATA ON SF6 GAS					
	a) Quantity of SF6 per pole	kg	27			
	b) Guaranteed maximum leakage rate	%/annum	Less than 1% per annum			
	c) Rated pressure of SF6 gas in operating chamber at 20°C	kg/cm ² gauge	7			
	d) Operating pressure range	kg/cm ² gauge	6.0 - 7.0			

1. Minimum 300mm plinth shall be maintained for CT/PT/CVT/Isolators/IV/LA/Breakers in the Substation during foundation works to ensure safe live to ground clearance as per IS rules.
 2. Since the supply of terminal connectors is not in the scope of manufacturer as mentioned in the drawings. The EPC contractor shall be instructed to supply the same in line with CT/PT/CVT/Isolator/IV/LA/Breakers requirement and compatibility.

NOTE: 1. DRAWING APPROVAL SUBJECT TO VALID TYPE TEST REPORTS, TO BE CHECKED DURING ACCEPTANCE TESTS
 2. FOR EPC CONTRACTS ONLY

Chief Engineer/Projects
 APTRANSCO/VS/Vijayawada.

8826877/2024/EE MRT-ENE51

e)	Filling ratio		0.75
f)	Capacity of SF6 gas cylinder	kg	50
g)	Spare gas provided		20%
h)	Whether breakers are dispatched filled with gas		Partially filled to 0.5 to 1 kg/cm ² dispatched filled with gas for transportation & storage to be topped at site
i)	Parameters of SF6 gas		As per IEC-60376
j)	Gas pressure settings at 20°C)		
i.	Low pressure alarm at	kg/cm ² gauge	6.5 +/- 0.3
ii.	Lockout pressure for		
a)	Opening	kg/cm ² gauge	6 +/- 0.3
b)	Closing	kg/cm ² gauge	6 +/- 0.3
6	GENERAL DIMENSIONS		
a)	Over all Dimensions		
i.	Length	mm	15600
ii.	Width	mm	5300
iii.	Height	mm	7400
b)	Weight of complete breaker for foundation design	kg	9800
c)	Weight of each pole	kg	3267
d)	Weight of Mechanism + Housing	kg	1000
e)	Weight of the heaviest part of the breaker	kg	2200 (Pole)
f)	Impact loading for foundation design		
i.	Downwords	kg	8000
ii.	Upwords	kg	5000
g)	Terminal Load		
i.	Cantilver strength - Horizontal	kg	100
ii.	Cantilver strength - Vertical	kg	125
h)	Seismic level	g	0.3
i)	Minimum clearance in air		
i.	Between live parts (without PIR)	mm	as per GA
i.	Between live parts (with PIR)	mm	as per GA
ii.	Between phases (Centre to Centre)	mm	as per GA
iii.	Live parts to earth	mm	as per GA
iv.	Live parts to ground level including plinth of 300 mm	mm	as per GA
j)	Noise level distance of		
i.	0M from the breaker	db	< 140
ii.	50 M from the breaker	db	< 140
iii.	100M from the breaker	db	< 140
iv.	150M from the breaker	db	< 140
k)	Packing Dimensions		
i.	Interrupter Assy (Total 3 nos)	mm	
ii.	Support Assy (Total 3 nos)	mm	
iii.	Mechanism Housing Assy. (Total 3 nos)	mm	
iv.	Marshalling box (Total 1 no)	mm	
7	CONSTRUCTIONAL DETAILS		
a)	Weight of absorbant per pole	gm	1000
b)	Whether arcing contacts are provided		Yes
c)	Type and material of arcing contacts		Tulip, Copper-Tungsten
d)	Type and Material of main contacts		Multifinger crown, Copper-Ag alloy
e)	Whether main contacts are silver plated / Silver plating thickness		Yes / 15 microns
f)	Contact pressure on main contacts	kg/mm2	0.3
g)	Length of contact separation	mm	2 x 113
h)	Length of contact travel		2 x 140
i)	Rate of contact travel		
j)	Main contact resistance	μΩ	< 100
k)	Whether the making & breaking contacts are hermetically sealed		Yes
l)	No. of spare auxiliary contacts provided for Owner's use		
i.	Normally Open when breaker is open		10/11/12
ii.	Normally Closed when breaker is open		10/11/12
m)	Rated voltage of auxiliary contacts	V DC	220
n)	Type of auxiliary contacts		Rotary
o)	Continuous Current Carrying Capacity	A	20 for contact in series with coil and 10A for all other and spare contacts
p)	DC breaking current with 20 ms time constant	A	7.5 A at 264 VDC for contact in series with coil and 2A for all other and spare contacts
q)	Whether auxiliary contacts are silver plated		Yes
r)	Finish of exposed ferrous parts		Hardware are HDG/SS/DACRO
s)	Finish paint		As per customer requirement
i.	Offered to Domestic Customer's		Shade 631 of IS 5
ii.	Offered to International Customer's		
t)	Finish for Support Structure OR Columns		Hot Dip Galvanised
u)	Make of support porcelains		ARGILON-GERMANY/LIAONING SHUANGLING/FUSHUN HIGH TECH ELECTRIC/ LILING HUAXIN/LILING PUKOU INSULATORS/PRATHAMESH CERAMICS/IEC/ MODERN/ABIL

NOTE: 1. DRAWING APPROVAL SUBJECT TO VALID TYPE TEST REPORTS, TO BE CHECKED DURING ACCEPTANCE TESTS
2. FOR EPC CONTRACTS ONLY

Chief Engineer/Projects
APTRANSCO/VS/Vijayawada.

IF IN DOUBT ASK!

DRG.NO.:CG-420CSD-25MM-GA

1 / 3

RO

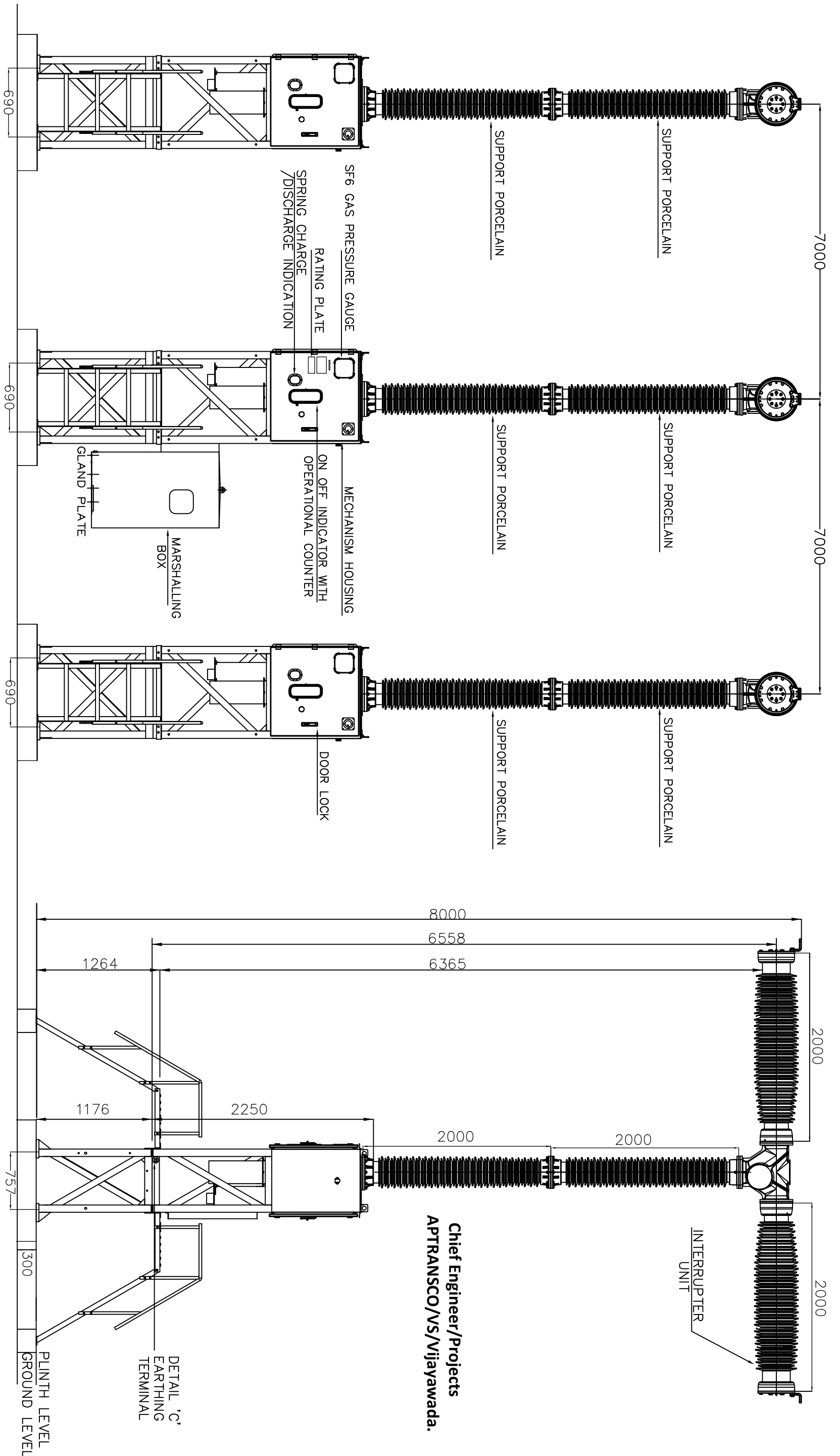

Drawing approval subject to valid vendor registration

- NOTE: 1. DRAWING APPROVAL SUBJECT TO VALID TYPE TEST REPORTS, TO BE CHECKED DURING ACCEPTANCE TESTS
2. FOR EPC CONTRACTS ONLY

NO	REVISION	2	NAME	DATE	DATE: 13.03.24	ALL DIMENSIONS ARE IN mm	DRG.NO.:CG-420CSD-25MM-GA	1 / 3	RO
5			NAME	CUSTOMER: APTRANSCO					
4			DRN	RSB	STD APPROVAL 25MM/KV CREEPAGE WITH CSD				
3			CHD	NSR			FOR: 420KV, 63 KA, SP SPR		
2			APPD	GNP			GCB TYPE: 400-SFM-60AA		
1			SCALE:	N.T.S.					
TITLE: GENERAL ARRANGEMENT							THIRD ANGLE PROJECTION		
 CG Power and Industrial Solutions Limited <small>SMITCHEGARA DIVISION SS,AMBAD, NASHIK.</small>									

IF IN DOUBT ASK!

NOTE: 1. DRAWING APPROVAL SUBJECT TO VALID TYPE TEST REPORTS, TO BE CHECKED DURING ACCEPTANCE TESTS
2. FOR EPC CONTRACTS ONLY

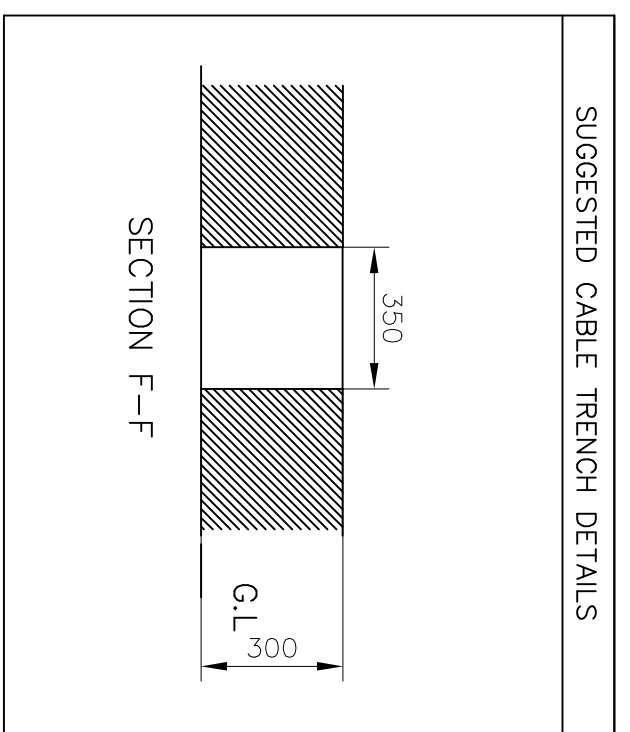
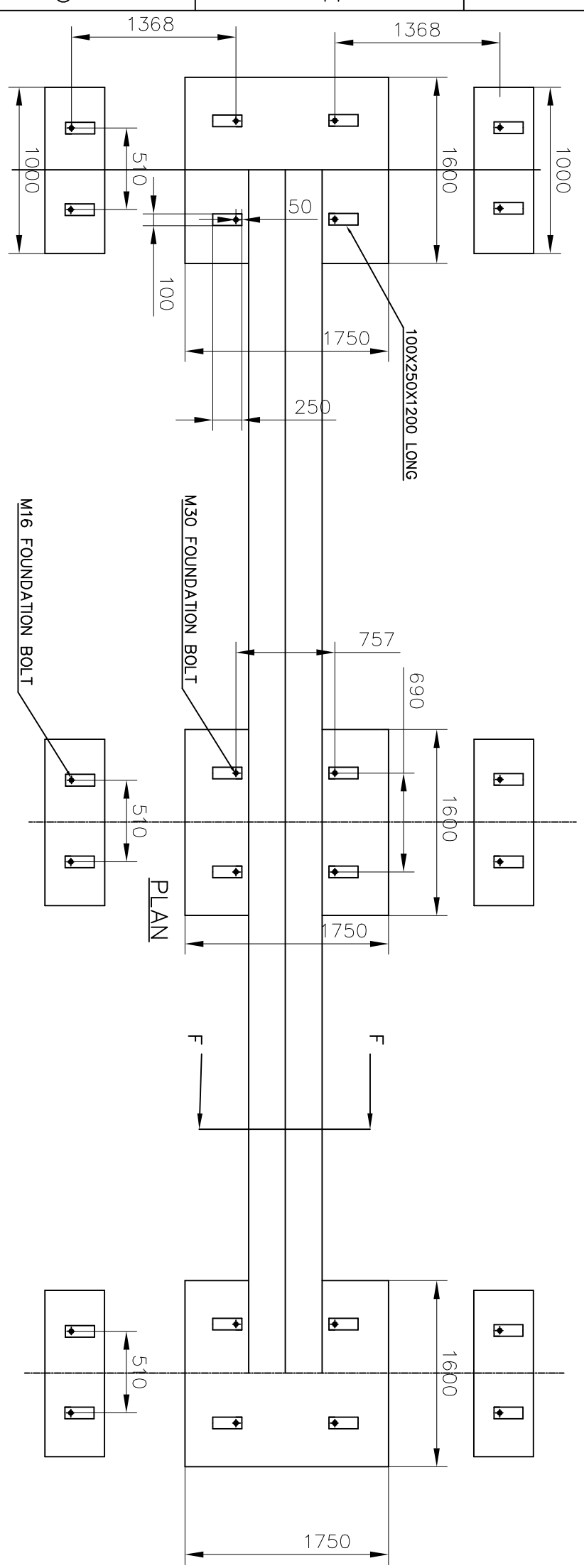

Drawing approval subject to valid vendor registration

Chief Engineer/Projects
APTRANSCO/VS/Vijayawada.

DETAILS OF TERMINAL PAD. MATERIAL :- ALUMINIUM THICKNESS :- 22mm		FOUNDATION BOLT FOR BREAKER		FOUNDATION BOLT FOR LADDER		EARTHING PAD DETAILS 'C'	
REVISION		NAME		DATE		TITLE: GENERAL ARRANGEMENT	
1		DRN	RSB	STD APPROVAL	25MM/KV CREEPAGE WITH CSD	THIRD ANGLE PROJECTION	
2		CHD	NSR	APPD	GNP	FOR: 420KV, 63 KA, SP SPR GCB TYPE: 400-SFM-60AA	
3		SCALE: N.T.S.		DRG.NO.:CG-420CSD-25MM-GA			
4		ALL DIMENSIONS ARE IN mm				CG Power and Industrial Solutions Limited SWITCHGEAR DIVISION SSAMBAD, NARSIPK	
5						2 / 3 RO	

NOTE: 1. DRAWING APPROVAL SUBJECT TO VALID TYPE TEST REPORTS, TO BE CHECKED DURING ACCEPTANCE TESTS
2. FOR EPC CONTRACTS ONLY

IF IN DOUBT ASK!

- NOTE:-
1. WEIGHT MECH.HOUSING =530kg/HSG (APPROX)
 2. TOTAL WEIGHT (3 PH) EXCLUDING SUPPORT STRUCTURE = 5600 kg (APPROX)
 3. SF6 GAS WEIGHT (3 PH) = 50 kg
 - 4a. OPERATING LOAD FOR FOUNDATION DESIGN PER PHASE 3200 kg/PHASE DOWNWARD, 1200kg/PHASE UPWARD
 - 4b. OPERATING LOAD FOR FOUNDATION DESIGN PER PHASE INCLUDING DEAD WEIGHT 8000 kg/PHASE DOWNWARD, 5000kg/PHASE UPWARD
 5. ALL EXPOSED FERROUS HARDWARES ARE HOT DIP GALVANISED OR S.STEEL
 6. INTER PHASE CABLE FROM EACH PHASE TO MARSHALLING BOX IS IN CGPISL SCOPE
 7. CREEPAGE DISTANCE TO GROUND IS 10500mm.
CREEPAGE DISTANCE ACROSS INTERRUPTER IS 10500mm.
 8. TYPE OF BREAKER: 400-SFM-60AA.
 9. STD APPLICATION : IEC-62271-100.
 10. RATED VOLTAGE = 420 kV rms.
 11. RATED CURRENT = UP TO 4000 A
 12. RATED OPERATING DUTY = 0-0.3 SEC-CO-3MIN-CO.
 13. RATED SF6 GAS PRESSURE = 6.5kg/cm² (g) AT 20°.
 14. HOUSING AND MB ARE PAINTED/POWDER COATED WITH 631 OF IS:5 EXT & INT.
 15. CABLE GLANDS & ANCHOR BOLTS ARE IN CGPISL SCOPE OF SUPPLY.
 16. PORCELAIN MAKE: MODERN/ABIL/IEC
 17. SUPPORT STRUCTURE IS HOT DIP GALVANISED WITH THICKNESS 127 MICRON

Chief Engineer/Projects
APTRANSCO/VS/Vijayawada.

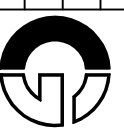
5		NAME	CUSTOMER: APTRANSCO	TITLE: GENERAL ARRANGEMENT	THIRD ANGLE PROJECTION
4		DRN	STD APPROVAL 25MM/KV CREEPAGE WITH CSD	FOR: 420KV, 63 KA, SP SPR	 CG Power and Industrial Solutions Limited <small>SWITCHGEAR DIVISION SA,AMBAD, NASHIK</small>
3		CHD	NSR	GCB TYPE: 400-SFM-60AA	
2		APPD	GNP		
1		SCALE:	N.T.S.		
NO	REVISION	NAME	DATE	DATE:13.03.24	ALL DIMENSIONS ARE IN mm

NO	REVISION	2	NAME	DATE	13.03.24	ALL DIMENSIONS ARE IN mm
1						
2						
3						
4						
5						
NAME		CUSTOMER: APTRANSCO				
DRN		STD APPROVAL 25MM/KV CREEPAGE WITH CSD				
CHD		NSR				
APPD		GNP				
SCALE:		N.T.S.				
TITLE:		SCHEMATIC DIAGRAM				
WITH CSD						
FOR:		420KV, 63 KA, SP SPR				
GCB TYPE:		400-SFM-60AA				
DRG.NO.:		CG-420CSD-25MM-SCH				
THIRD ANGLE PROJECTION						

© CSD BYPASS SWITCH (4POLE 440VAC/DC 25A) IN LOCATED IN CRP AND NOT IN CGP/SL SCOPE OF SUPPLY
* CONTACTS OF MULTIPLICATION RELAY(CO AND CF CONTACTOR) REFER SHEET EHS-6388-08-01 FOR MORE DETAILS

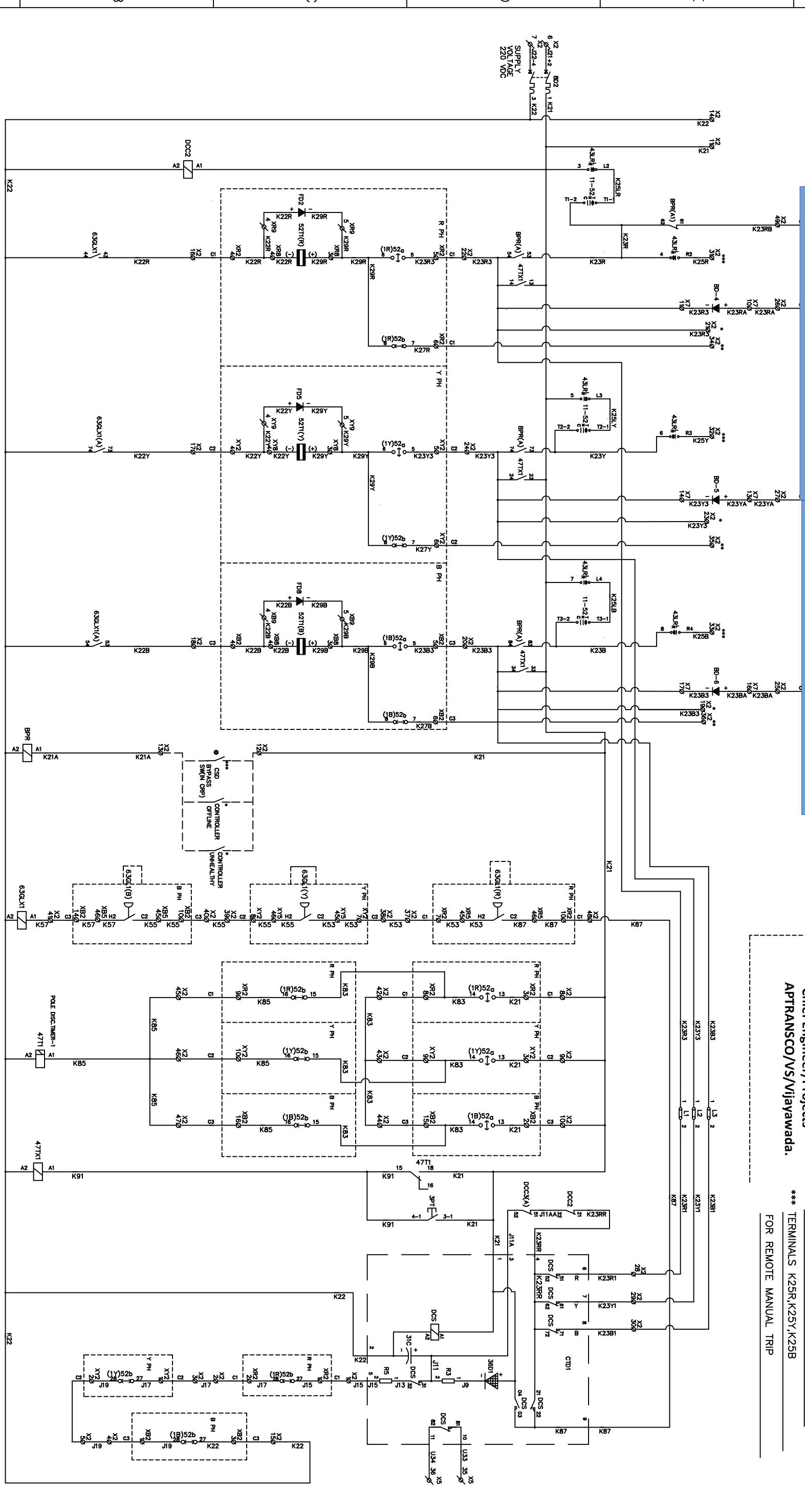

Chief Engineer/Projects
APTRANSCO/VS/Vijayawada.

- NOTE:-
- * TERMINALS K23R,K23Y,K23B FOR PROTECTION TRIP & TRIP SUPERVISION RELAY (POST CLOSING)
 - ** TERMINALS K27R,K27Y,K27B FOR PRECLOSING TRIP CIRCUIT SUPERVISION.
 - *** TERMINALS K25R,K25Y,K25B FOR REMOTE MANUAL TRIP

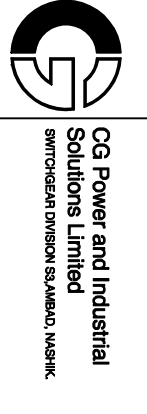

CG Power and Industrial Solutions Limited
SWITCHGEAR DIVISION SA/AMBD, NASHIK

IF IN DOUBT ASK!

NO	REVISION	2	NAME	DATE	13.03.24	ALL DIMENSIONS ARE IN mm
1						
2						
3						
4						
5						
6						
7						
8						

© CSD BYPASS SWITCH (4POLE 440VAC/DC 25A) IN LOCATED IN CRP AND NOT IN CGPISL SCOPE OF SUPPLY
* CONTACTS OF MULTIPLICATION RELAY(CO AND CF CONTACTOR) REFER SHEET EHS-6388-08-01 FOR MORE DETAILS

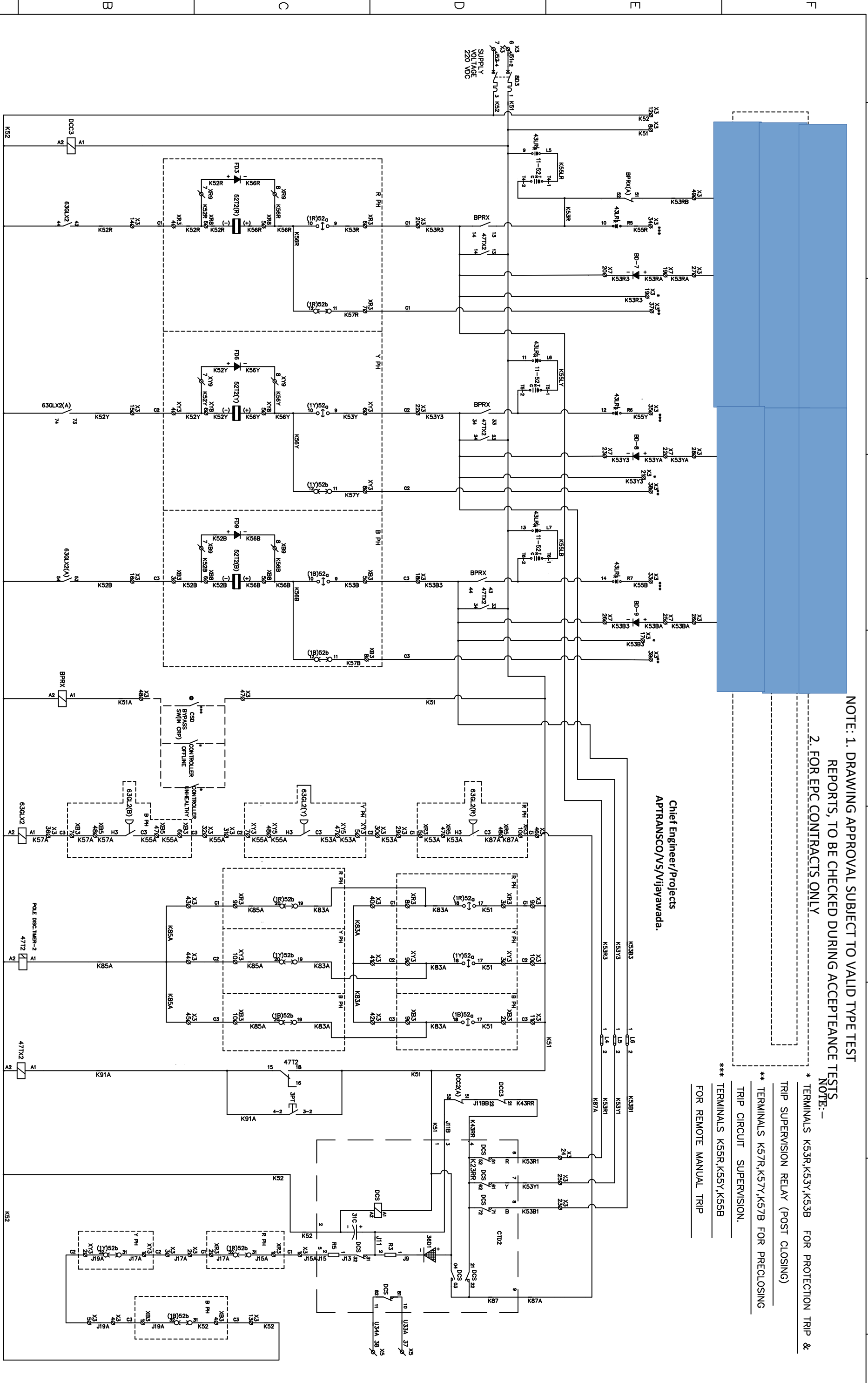

Chief Engineer/Projects
APTRANSCO/Vs/Vijayawada.

- *** TERMINALS K53R,K53Y,K53B FOR PROTECTION TRIP & TRIP SUPERVISION RELAY (POST CLOSING)
- ** TERMINALS K57R,K57Y,K57B FOR PRECLOSING TRIP CIRCUIT SUPERVISION.
- *** TERMINALS K55R,K55Y,K55B FOR REMOTE MANUAL TRIP

NOTE: 1. DRAWING APPROVAL SUBJECT TO VALID TYPE TEST REPORTS, TO BE CHECKED DURING ACCEPTANCE TESTS
2. FOR EPC CONTRACTS ONLY

TITLE: SCHEMATIC DIAGRAM WITH CSD

THIRD ANGLE PROJECTION

FOR: 420KV, 63 KA, SP SPR
GCB TYPE: 400-SFM-60AA



IF IN DOUBT ASK!

NO	REVISION	2	NAME	DATE	DATE:13.03.24	ALL DIMENSIONS ARE IN mm
1						
2						
3						
4						
5						

Drawing approval subject to valid vendor registration

NOTE: 1. DRAWING APPROVAL SUBJECT TO VALID TYPE TEST REPORTS, TO BE CHECKED DURING ACCEPTANCE TESTS
2. FOR EPC CONTRACTS ONLY

Chief Engineer/Projects
APTRANSCO/VS/Vijawada.

TITLE: SCHEMATIC DIAGRAM WITH CSD	THIRD ANGLE PROJECTION
FOR: 420KV, 63 KA, SP SPR	CG Power and Industrial Solutions Limited
GCB TYPE: 400-SFM-60AA	SWITCHGEAR DIVISION SA.AMBAD, NASHIK
DRG.NO.:CG-420CSD-25MM-SCH	

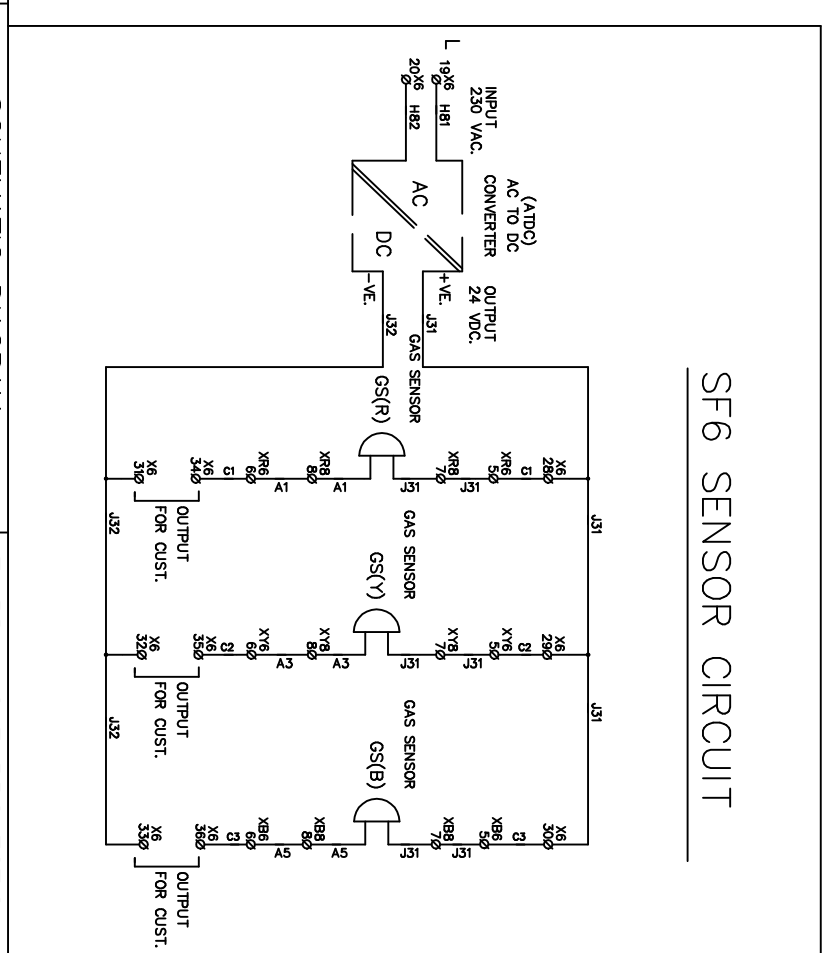
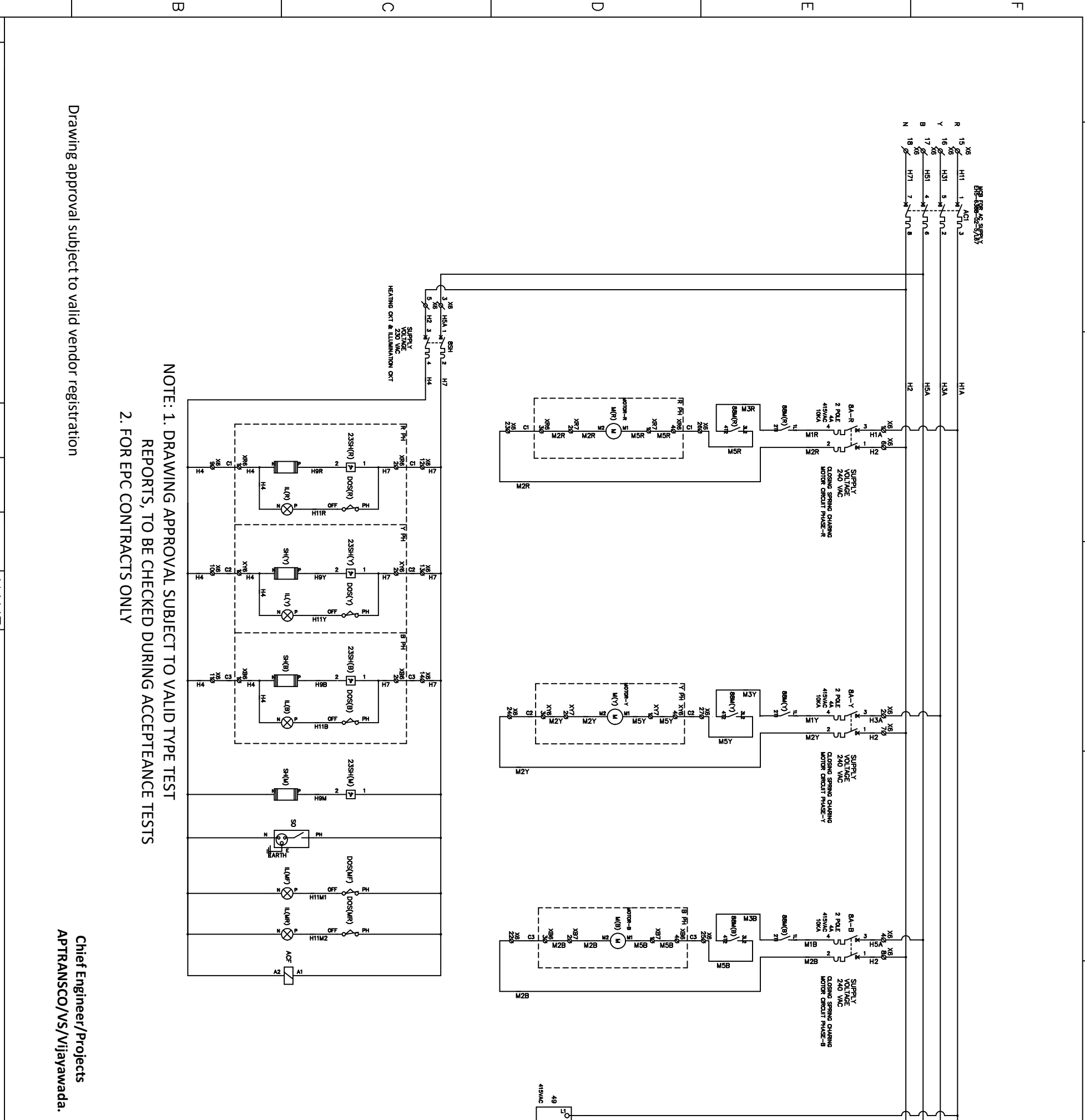

1. Minimum 300mm plinth shall be maintained for CT/PT/CVT/Isolators/IV/LA/Breakers in the Substation during foundation works to ensure safe live to ground clearance as per IE rules.
2. Since the supply of terminal connectors is not in the scope of manufacturer as mentioned in the drawings. The EPC contractor shall be instructed to supply the same in line with CT/PT/CVT/Isolator/IVT/LA/Breakers requirement and compatibility.

IF IN DOUBT ASK!

DRG.NO.:CG-420CSD-25MM-SCH

6 / 7 RO

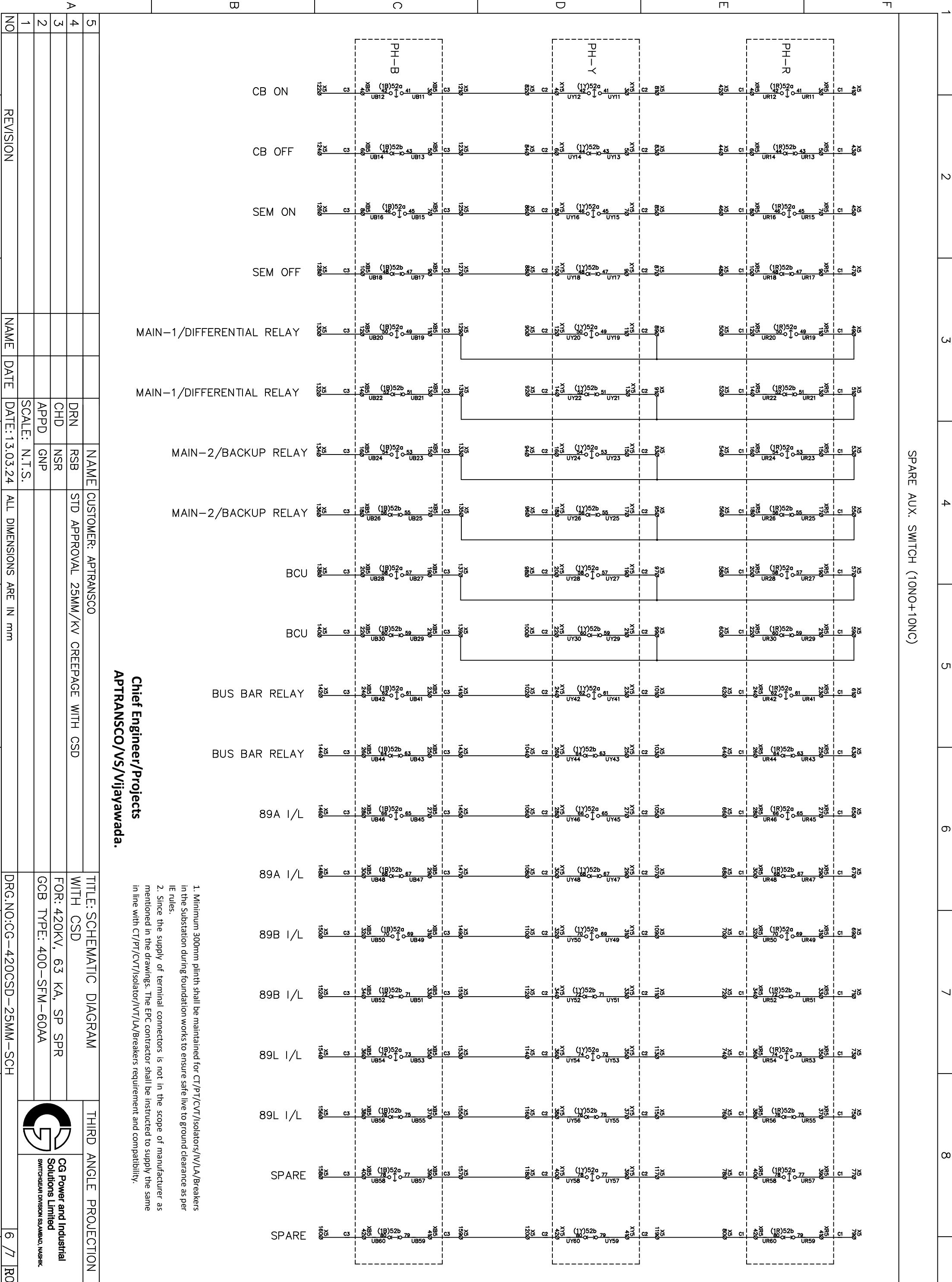

NO	REVISION	NAME	DATE	ALL DIMENSIONS ARE IN mm
1				
2				
3				
4				
5				

Chief Engineer/Projects
APTRANSCO/VS/Vijayawada.

1. Minimum 300mm plinth shall be maintained for CT/PT/CVT/Isolators/V/LA/Breakers in the Substation during foundation works to ensure safe live to ground clearance as per IE rules.
2. Since the supply of terminal connectors is not in the scope of manufacturer as mentioned in the drawings. The EPC contractor shall be instructed to supply the same in line with CT/PT/CVT/Isolator/V/LA/Breakers requirement and compatibility.

TITLE: SCHEMATIC DIAGRAM WITH CSD	THIRD ANGLE PROJECTION
FOR: 420KV, 63 KA, SP SPR	
GCB TYPE: 400-SFM-60AA	
DRG.NO.:CG-420CSD-25MM-SCH	

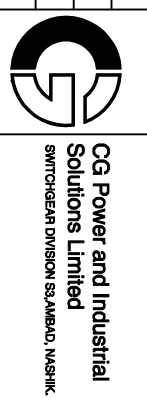

IF IN DOUBT ASK!

NO	REVISION	NAME	DATE	DATE	ALL DIMENSIONS ARE IN mm	QUANT	RATING1	RATING2	MFG
3PT		PUSH BUTTON (RED) (2NO)				1	250VDC	10A	TEKNIC /GRAITECH /DSQUARE
BA-B		MINIATURE CIRCUIT BREAKER(MCB),C CURVE			1	2 POLE	4A	SCHNEIDER/SIEMENS/EATON	
BA-R		MINIATURE CIRCUIT BREAKER(MCB),C CURVE			1	2 POLE	4A	SCHNEIDER/SIEMENS/EATON	
BA-Y		MINIATURE CIRCUIT BREAKER(MCB),C CURVE			1	2 POLE	4A	SCHNEIDER/SIEMENS/EATON	
B01		MINIATURE CIRCUIT BREAKER(DC MCB),C CURVE			1	2 POLE	16A	SCHNEIDER/SIEMENS/EATON	
B02		MINIATURE CIRCUIT BREAKER(DC MCB),C CURVE			1	2 POLE	16A	SCHNEIDER/SIEMENS/EATON	
B03		MINIATURE CIRCUIT BREAKER(DC MCB),C CURVE			1	2 POLE	16A	SCHNEIDER/SIEMENS/EATON	
B04		MINIATURE CIRCUIT BREAKER(DC MCB),C CURVE			1	2 POLE	16A	SCHNEIDER/SIEMENS/EATON	
B8H		MINIATURE CIRCUIT BREAKER(MCB),C CURVE			1	2 POLE	16A	SCHNEIDER/SIEMENS/EATON	
11-52		TRIP-NEUTRAL-CLOSE SW. 7 POLE,(7+7C) 3 POSITION, 45deg ANGLE, SPRING RETURN.			1	660V AC/DC	32A	SMITRON /SHIRKE	
23SH(B)		THERMOSTAT FOR HEATER CONTROL			1	230 VAC		APT/VELICO/ELEXPERC	
23SH(M)		THERMOSTAT FOR HEATER CONTROL			1	230 VAC		APT/VELICO/ELEXPERC	
23SH(R)		THERMOSTAT FOR HEATER CONTROL			1	230 VAC		APT/VELICO/ELEXPERC	
23SH(Y)		THERMOSTAT FOR HEATER CONTROL			1	230 VAC		APT/VELICO/ELEXPERC	
43LR		LOCAL-REMOTE SWITCH (9L+9R), 2 POSITION, 90deg, STAY PUT TYPE			1	660V AC/DC	32A	SMITRON /SHIRKE	
47T1		POLE DISCREPANCY TIMER			1	24V-240V DC/AC	0.1sec-1200h	OMRON /SELEC	
47T2		POLE DISCREPANCY TIMER			1	24V-240V DC/AC	0.1sec-1200h	OMRON /SELEC	
47TX1		AUXILIARY CONTACTOR 4NO			1	220VDC		SCHNEIDER/SIEMENS/EATON	
47TX2		AUXILIARY CONTACTOR 4NO			1	220VDC		SCHNEIDER/SIEMENS/EATON	
49		PHASE FAILURE RELAY			1	415VAC		SCHNEIDER/SIEMENS/EATON	
52C(B)		CLOSE COIL FOR 400kV SP SPR/245kV SP GO			1	220 VDC	121 ohm +/- 5%	POWERINST/ECS/SUN ENGG	
52C(R)		CLOSE COIL FOR 400kV SP SPR/245kV SP GO			1	220 VDC	121 ohm +/- 5%	POWERINST/ECS/SUN ENGG	
52C(Y)		CLOSE COIL FOR 400kV SP SPR/245kV SP GO			1	220 VDC	121 ohm +/- 5%	POWERINST/ECS/SUN ENGG	
52T(B)		TRIP COIL(1)			1	220 VDC	121 ohm +/- 5%	POWERINST/ECS/SUN ENGG	
52T(R)		TRIP COIL(1)			1	220 VDC	121 ohm +/- 5%	POWERINST/ECS/SUN ENGG	
52T(Y)		TRIP COIL(1)			1	220 VDC	121 ohm +/- 5%	POWERINST/ECS/SUN ENGG	
52T2(B)		TRIP COIL(2)			1	220 VDC	121 ohm +/- 5%	POWERINST/ECS/SUN ENGG	
52T2(R)		TRIP COIL(2)			1	220 VDC	121 ohm +/- 5%	POWERINST/ECS/SUN ENGG	
52T2(Y)		TRIP COIL(2)			1	220 VDC	121 ohm +/- 5%	POWERINST/ECS/SUN ENGG	
52Y(B)		AUXILIARY CONTACTOR 2NO+2NC			1	220VDC		SCHNEIDER/SIEMENS/EATON	
52Y(R)		AUXILIARY CONTACTOR 2NO+2NC			1	220VDC		SCHNEIDER/SIEMENS/EATON	
52Y(Y)		AUXILIARY CONTACTOR 2NO+2NC			1	220VDC		SCHNEIDER/SIEMENS/EATON	
63GA(B)		GAS DENSITY SWITCH ALARM (NO):ON-6.0 kg/sq.cm,OFF-6.5 kg/sq.cm at 200C			1			REGENCY ELECTRIC/TAFAAG	
63GA(R)		GAS DENSITY SWITCH ALARM (NO):ON-6.0 kg/sq.cm,OFF-6.5 kg/sq.cm at 200C			1			REGENCY ELECTRIC/TAFAAG	
63GA(Y)		GAS DENSITY SWITCH ALARM (NO):ON-6.0 kg/sq.cm,OFF-6.5 kg/sq.cm at 200C			1			REGENCY ELECTRIC/TAFAAG	
63GL1(B)		GAS DENSITY SWITCH LOCKOUT (NO):OFF-5.5 kg/sq.cm,ON-6.0 kg/sq.cm at 200C			1			REGENCY ELECTRIC/TAFAAG	
63GL1(R)		GAS DENSITY SWITCH LOCKOUT (NO):OFF-5.5 kg/sq.cm,ON-6.0 kg/sq.cm at 200C			1			REGENCY ELECTRIC/TAFAAG	
63GL1(Y)		GAS DENSITY SWITCH LOCKOUT (NO):OFF-5.5 kg/sq.cm,ON-6.0 kg/sq.cm at 200C			1			REGENCY ELECTRIC/TAFAAG	
63GL2(B)		GAS DENSITY SWITCH LOCKOUT (NO):OFF-5.5 kg/sq.cm,ON-6.0 kg/sq.cm at 200C			1			REGENCY ELECTRIC/TAFAAG	
63GL2(R)		GAS DENSITY SWITCH LOCKOUT (NO):OFF-5.5 kg/sq.cm,ON-6.0 kg/sq.cm at 200C			1			REGENCY ELECTRIC/TAFAAG	
63GL2(Y)		GAS DENSITY SWITCH LOCKOUT (NO):OFF-5.5 kg/sq.cm,ON-6.0 kg/sq.cm at 200C			1			REGENCY ELECTRIC/TAFAAG	
63GLX1		AUXILIARY CONTACTOR 2NO+2NC			1	220VDC		SCHNEIDER/SIEMENS/EATON	
63GLX1(A)		ADD ON BLOCK (4NO)			1			SCHNEIDER/SIEMENS/EATON	
63GLX2		AUXILIARY CONTACTOR 2NO+2NC			1	220VDC		SCHNEIDER/SIEMENS/EATON	
63GLX2(A)		ADD ON BLOCK (4NO)			1			SCHNEIDER/SIEMENS/EATON	

NOTES:-

- AUXILIARY SWITCHES ARE SHOWN FOR OPEN BREAKER.
- AUXILIARY CONTACTORS CONTACTS ARE SHOWN IN DE-ENERGISED POSITION.
- GAS PRESSURE SWITCH IS SHOWN FOR NO GAS PRESSURE.
- LOCAL REMOTE CHANGEOVER SWITCH IS SHOWN IN REMOTE POSITION.
 - ARE OPEN CONTACTS
 - ARE CLOSE CONTACTS.
 - CHANGEOVER CONTACT.
- SIZE OF WIRE =1.5 sq.mm. MULTI STRANDED COPPER(FLEXIBLE) CONDUCTOR PVC INSULATED.
- COLOUR OF WIRE FOR AC CIRCUIT-R,Y,B & BLACK, FOR DC CIRCUIT & SPARE CONTACTS-GRAY & FOR EARTHING-GREEN.
- STUD TYPE TERMINAL BLOCKS ARE PROVIDED.
- CONTINUOUS CURRENT CARRYING CAPACITY OF TRIP COIL IS 50ma TO CATER FOR TRIP COIL SUPERVISION.
- 52a CONTACTS ARE OPEN WHEN BREAKER IS OPEN.
- 52b CONTACTS ARE CLOSE WHEN BREAKER IS OPEN.
- *ø* TERMINAL ARE WIRED UPTO TERMINAL BLOCKS FOR REMOTE CONTROL PANEL OF CIRCUIT BREAKER.
- THE COMPONENTS IN THIS BILL OF MATERIAL ARE MANUFACTURED BY DIFFERENT OEM'S & MAY HAVE DIFFERENT RATINGS MENTIONED ON COMPONENTS. HOWEVER, CG STANDS FOR THE GUARANTEE FOR THE GUARANTEE FOR ITS PERFORMANCE & SUITABILITY AS PER THE REQUIREMENTS.

NO	REVISION	NAME	DATE	DATE	ALL DIMENSIONS ARE IN mm	TITLE: BILL OF MATERIAL	THIRD ANGLE PROJECTION
5							
4							
3		DRN				FOR: 420KV, 63 KA, SP SPR	
2		CHD				GCB TYPE: 400-SFM-60AA	
1		APPD					
1		SCALE: N.T.S.					
1						DRG.NO.:CG-420CSD-25MM-BOM	

CG Power and Industrial Solutions Limited

 SWITCHGEAR DIVISION 53,AMBAD, NASHIK

Chief Engineer/Projects
APTRANSOCO/VS/Vijayawada.

IF IN DOUBT ASK!

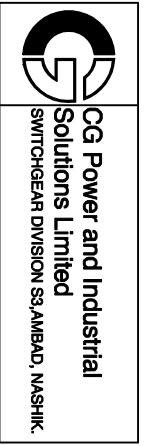
Drawing approval subject to valid vendor registration



MADE IN INDIA

GAS CIRCUIT BREAKER

TYPE: 400-SFM-60AA	STD. IEC62271-100	CLASS: C2-M2
RATED VOLTAGE	420 kV	RATED LIGHTNING IMPULSE WITHSTAND VOLTAGE
RATED FREQUENCY	50 Hz	1425kVp
RATED NORMAL CURRENT	4000A	RATED SHORT CIRCUIT BREAKING CURRENT
FIRST POLE TO CLEAR FACTOR	1.3	63kA
RATED SF6 GAS PRESSURE	6.5kg/cm ² g(AT 20°C)	RAT.OPR.SEQ. 0-0.3SEC-CO-3MIN-CO
TOTAL WT. 5600 kg	GAS WT 50 kg	RATED SWITCHING IMPULSE WITHSTAND VOLTAGE
RATED DURATION OF SHORT CIRCUIT CURRENT	63kA 3 SECS.	RATED POWER FREQUENCY WITHSTAND VOLTAGE
SF6 GAS MAXIMUM WORKING PRESSURE	6.5kg/cm ² g(AT 20°C)	SF6 GAS ALARM PRESSURE
SF6 GAS LOCKOUT PRESSURE	5.5kg/cm ² g(AT 20°C)	MINIMUM CREEPAGE DISTANCE:
		10500 mm.

NOTE: 1. DRAWING APPROVAL SUBJECT TO VALID TYPE TEST REPORTS, TO BE CHECKED DURING ACCEPTANCE TESTS
2. FOR EPC CONTRACTS ONLY

SCAN QR CODE FOR PRODUCT MANUAL			
RATED COIL VOLTAGE - TRIPPING	220V DC	RATED COIL VOLTAGE - CLOSING	220V DC
MOTOR VOLTAGE	230V AC	AUX CIRCUIT VOLTAGE	1φ, 230V AC, 50HZ.
YEAR: **			
CUSTOMER: APTRANSCO			
STD APPROVAL 25MM/KV CREEPAGE WITH CSD			

SR. NO. : *

MATERIAL: S.S AISI 2mm THK
DEPTH OF LETTER 0.5THK

* SR. NO: _____ QTY.: _____ NOS

** CURRENT YEAR OF MANUFACTURING

Chief Engineer/Projects
APTRANSCO/VS/Vijayawada.

5				NAME	CUSTOMER: APTRANSCO	TITLE: RATING PLATE	THIRD ANGLE PROJECTION
4				DRN	STD APPROVAL 25MM/KV CREEPAGE WITH CSD	FOR: 420KV, 63 KA, SP SPR	CG Power and Industrial Solutions Limited SWITCHGEAR DIVISION SS,AMBAD, NASHIK
3				CHD		GCB TYPE: 400-SFM-60AA	
2				APPD			
1				SCALE: N.T.S.			
NO	REVISION	2	3	NAME	DATE	DATE: 13.03.24	DRG.NO.:CG-420CSD-25MM-RP
1		2	3				1 / 1

IF IN DOUBT ASK!

NOTE: 1. DRAWING APPROVAL SUBJECT TO VALID TYPE TEST REPORTS, TO BE CHECKED DURING ACCEPTANCE TESTS
2. FOR EPC CONTRACTS ONLY

Drawing approval subject to valid vendor registration

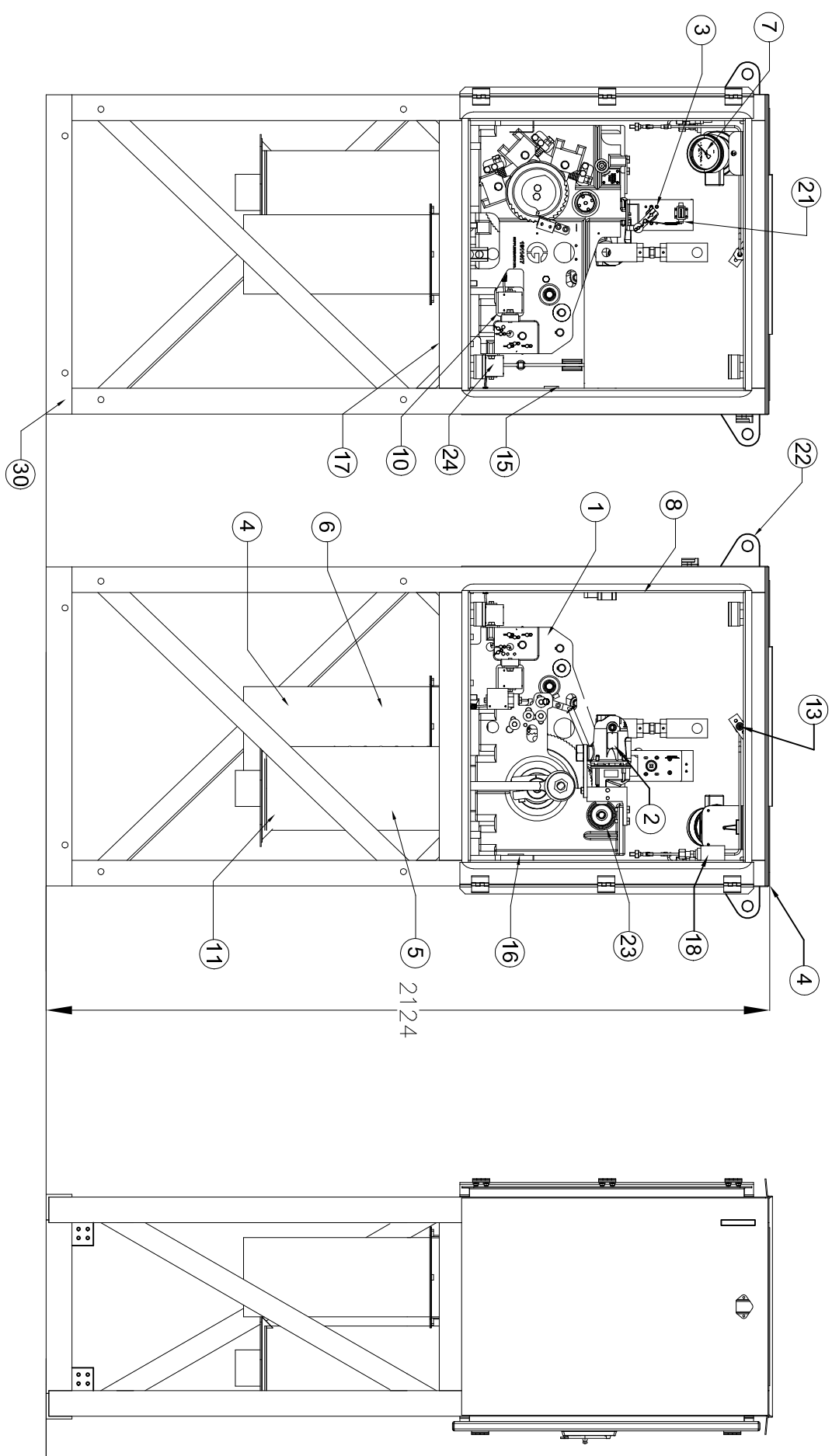

QTY.	ITEM	DESCRIPTION
1	1	MECHANISM ASSEMBLY
1	2	MOTOR
1	3	AUX SWITCHES ASSEMBLY
1	4	MECHANISM HOUSING ASSEMBLY
1	5	CLOSING SPRING ASSEMBLY
1	6	TRIP SPRING ASSEMBLY WITH SHOCK ABSORBER
1	7	GAS PRESSURE GAUGE* / GAS PRESSURE SWITCH & GAUGE**
1	8	TERMINAL BLOCKS
1	9	CLOSING COIL ASSEMBLY
1	10	TRIP COIL-1 COIL ASSEMBLY
1	11	COVER FOR CLOSING SPRING
1	12	COVER FOR TRIPPING SPRING
1	13	GAS PRESSURE PORT
1	14	CONTROL PANEL
1	15	THERMOSTAT
1	16	SPACE HEATER
1	17	GLAND PLATE
1	18	GAS PRESSURE SWITCH*
1	19	ILLUMINATION LAMP
1	20	MECH.ON/OFF INDICATOR
1	21	MECH.OPERATING COUNTER
2	22	LIFTING HOOK
1	23	MANUAL SPRING CHARGING PORT
1	24	TRIP COIL-2 COIL ASSEMBLY

FRONT VIEW

REAR VIEW

SIDE VIEW

- NOTE:
1. TOLERANCE ON OVERALL DIM ± 2 %
 2. THIS DRAWING IS INDICATIVE .THE POSITION OF COMPONENT MAY CHANGE IN MANUFACTURING STAGE.
 3. IN CASE OF GAS DENSITY SWITCH:
 * FOR SAGINOMIYA MAKE GAUGE AND SWITCH ARE SEPARATE/
 ** FOR REGENCY ELECTRIC GAUGE AND SWITCH ARE COMBINE
 - 4) INGRESS OF PROTECTION IP 55
 - 5) GAS PRESSURE GAUGE IS PROVIDED WITH RED, GREEN AND YELLOW COLOUR ZONE
 - 6) MATERIAL : M.S. SHEET 3.0 mm THK

Chief Engineer/Projects
APTRANSCO/Vs/Vijayawada.

NO	REVISION	2	NAME	DATE	DATE:13.03.24	ALL DIMENSIONS ARE IN mm
1						
2						
3						
4						
5						

TITLE: MECHANISM HOUSING	THIRD ANGLE PROJECTION
CUSTOMER: APTRANSCO	
DRN	RSB
CHD	NSR
APPD	GNP
SCALE: N.T.S.	
FOR: 420KV, 63 KA, SP SPR	
GCB TYPE: 400-SFM-60AA	
DRG.NO.:CG-420CSD-25MM-MH	

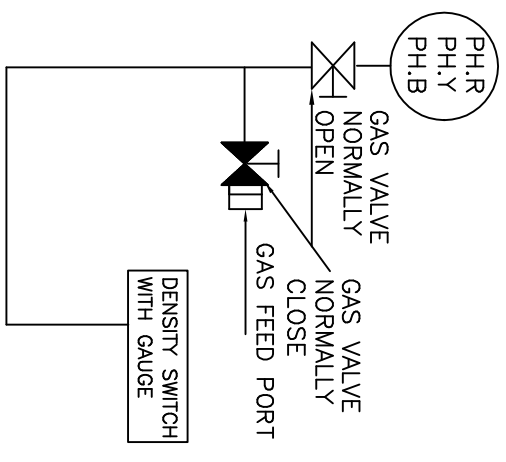

CG Power and Industrial Solutions Limited
 SWITCHGEAR DIVISION SS,AMBAD, NASHIK

IF IN DOUBT ASK!

NOTE: 1. DRAWING APPROVAL SUBJECT TO VALID TYPE TEST REPORTS, TO BE CHECKED DURING ACCEPTANCE TESTS
2. FOR EPC CONTRACTS ONLY

Drawing approval subject to valid vendor registration

1. Minimum 300mm plinth shall be maintained for CT/PT/CVT/Isolators/IV/LA/Breakers in the Substation during foundation works to ensure safe live to ground clearance as per IE rules.
2. Since the supply of terminal connectors is not in the scope of manufacturer as mentioned in the drawings. The EPC contractor shall be instructed to supply the same in line with CT/PT/CVT/Isolator/VT/LA/Breakers requirement and compatibility.

- NOTES:
1. DEGREE OF PROTECTION OF IP:55
 2. FINISH :- PAINTED/POWDER COATED AS PER 631 OF IS:5.
 3. TOLERANCE ON OVERALL DIM $\pm 2\%$
 4. THIS DRAWING IS INDICATIVE. THE POSITION OF COMPONENT MAY CHANGE IN MANUFACTURING STAGE.

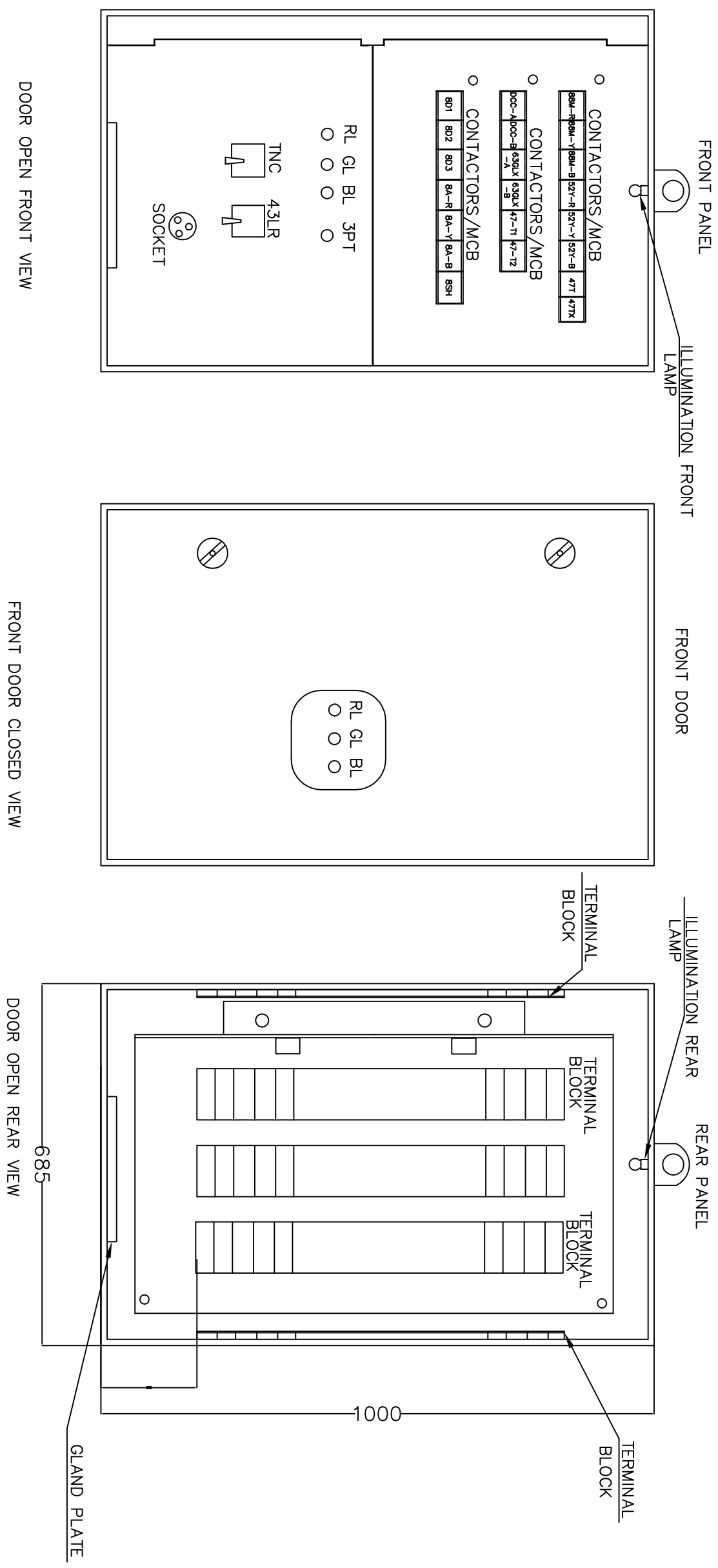

NO	REVISION	2	NAME	DATE	DATE:13.03.24	ALL DIMENSIONS ARE IN mm	DRG.NO.:CG-420CSD-25MM-MB
1							
2							
3							
4							
5							

5							
4							
3							
2							
1							

TITLE: MARSHALLING BOX DETAILS	THIRD ANGLE PROJECTION
FOR: 420KV, 63 KA, SP SPR	CG Power and Industrial Solutions Limited
GCB TYPE: 400-SFM-60AA	SWITCHGEAR DIVISION, SA. AMBAD, NASHIK
DRG.NO.:CG-420CSD-25MM-MB	1 / 1 RO

NAME: APTRANSCO
CUSTOMER: APTRANSCO
STD APPROVAL 25MM/KV CREEPAGE WITH CSD

Chief Engineer/Projects
APTRANSCO/Vs/Vijayawada.

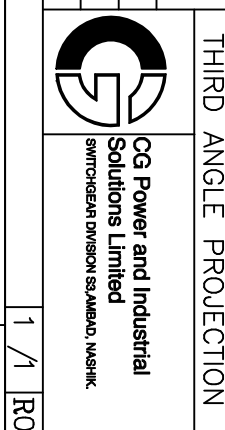

IF IN DOUBT ASK!

NOTE: 1. DRAWING APPROVAL SUBJECT TO VALID TYPE TEST REPORTS, TO BE CHECKED DURING ACCEPTANCE TESTS
 2. FOR EPC CONTRACTS ONLY

Drawing approval subject to valid vendor registration

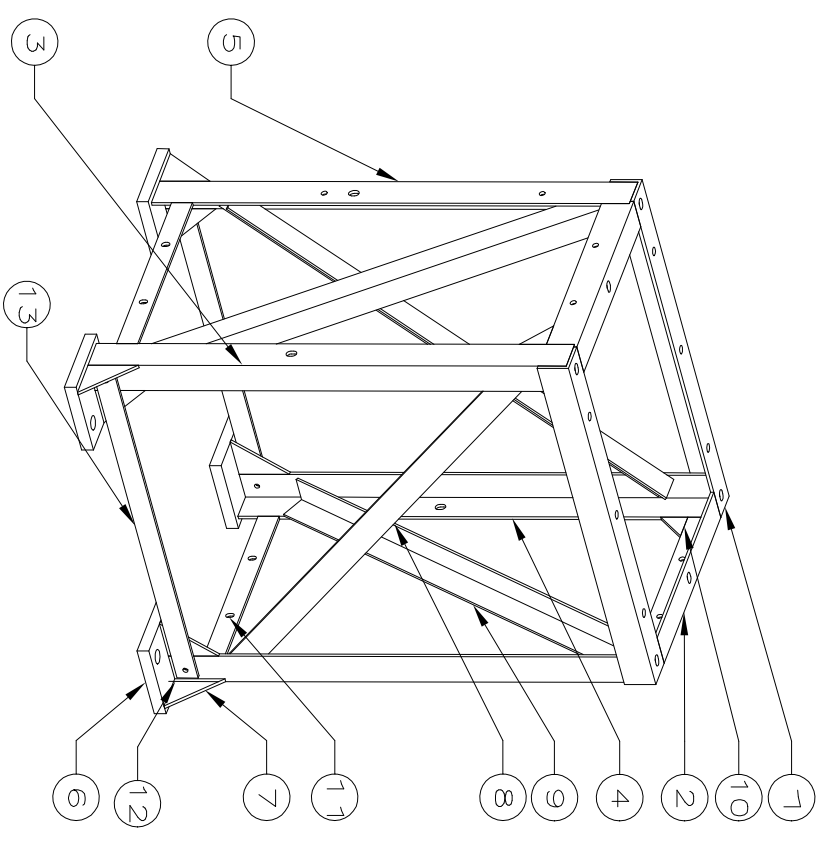
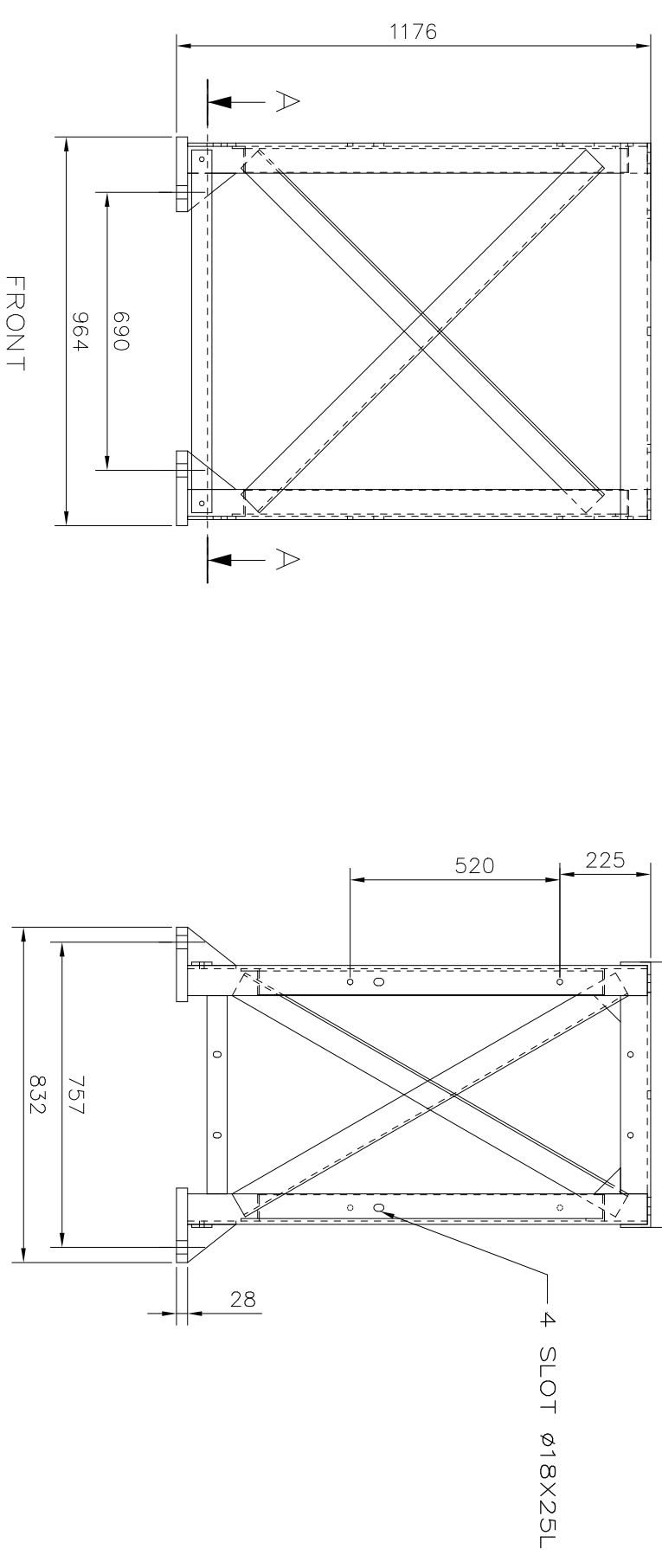
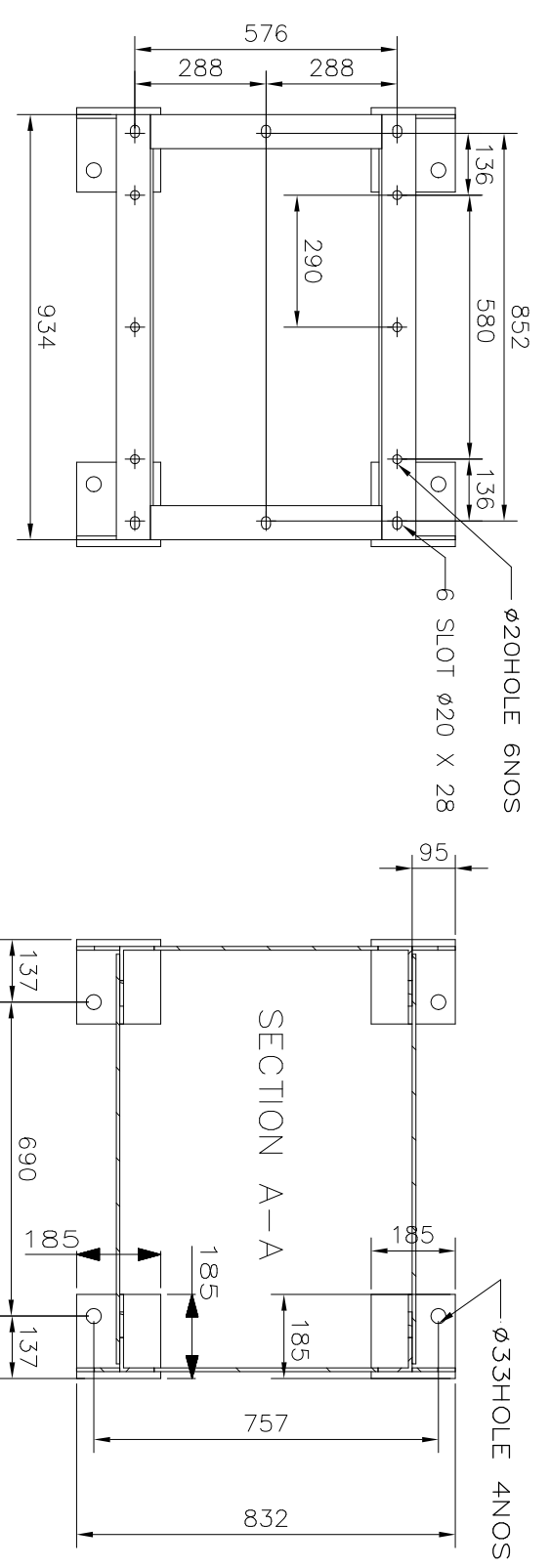

SR NO	DESCRIPTION	SIZE	QTY
1	TOP FRONT AND REAR ANGLE	8THKX75X75	2
2	TOP SIDE ANGLE	8THKX75X75	2
3	VERTICAL LEG	8THKX75X75	1
4	VERTICAL LEG	8THKX75X75	1
5	VERTICAL LEG	8THKX75X75	1
6	BASE PLATE	28THKX185X185	4
7	BOTTOM GUSSET	8THKX95X120	8
8	FRONT REAR CROSS BRACING	6THKX65X65	2
9	SIDE CROSS BRACING	6THKX65X65	2
10	TOP GUSSET	8THKX65X65	2
11	CABLE TRAY SUPPORT	8THKX50	2
12	VERTICAL LEG	8THKX75X75	1
13	SUPPORT PLATE	8THKX50	2

NOTE : 1) MINIMUM WEIGHT OF ZINC COATING 900 gm/sq.m OR MINIMUM THICKNESS OF COATING 127 MICRON FOR MEMBERS THICKER THAN 6MM FOR MEMBERS LOWER THAN 6MM THK MINIMUM THICKNESS OF COATING IS 86 MICRON MIN
 2) ALL DIMENSIONS ARE IN mm
 3) DIMENSIONS IN BRACKETS ARE FOR REFERENCE ONLY

Chief Engineer/Projects
APTRANSCO/VS/Vijayawada.

DIMENSIONS IN BRACKETS ARE FOR REFERENCE ONLY

UNSPECIFIED TOLERANCE		
MACHINE CUT	MEDIUM	COARSE
NOMINAL SIZE	1 TO 4	±0.3
	OVER 4 TO 16	±0.2
	OVER 16 TO 63	±0.3
	OVER 63 TO 250	±0.5
	OVER 250 TO 1000	±0.8
	OVER 1000 TO 2000	±1.2
	OVER 2000 TO 4000	±1.8

NO	REVISION	NAME	DATE	ALL DIMENSIONS ARE IN mm
1				
2				
3				
4				
5				

NO	REVISION	NAME	DATE	ALL DIMENSIONS ARE IN mm
1				
2				
3				
4				
5				

TITLE: SUPPORT STRUCTURE DETAILS
 FOR: 420KV, 63 KA, SP SPR
 GCB TYPE: 400-SFM-60AA

DRG.NO.:CG-420CSD-25MM-SS

THIRD ANGLE PROJECTION

CG Power and Industrial Solutions Limited
 SWITCHGEAR DIVISION SS,AMBAD, NASHIK

NO	REVISION	NAME	DATE	ALL DIMENSIONS ARE IN mm
1				
2				
3				
4				
5				
6				
7				
8				

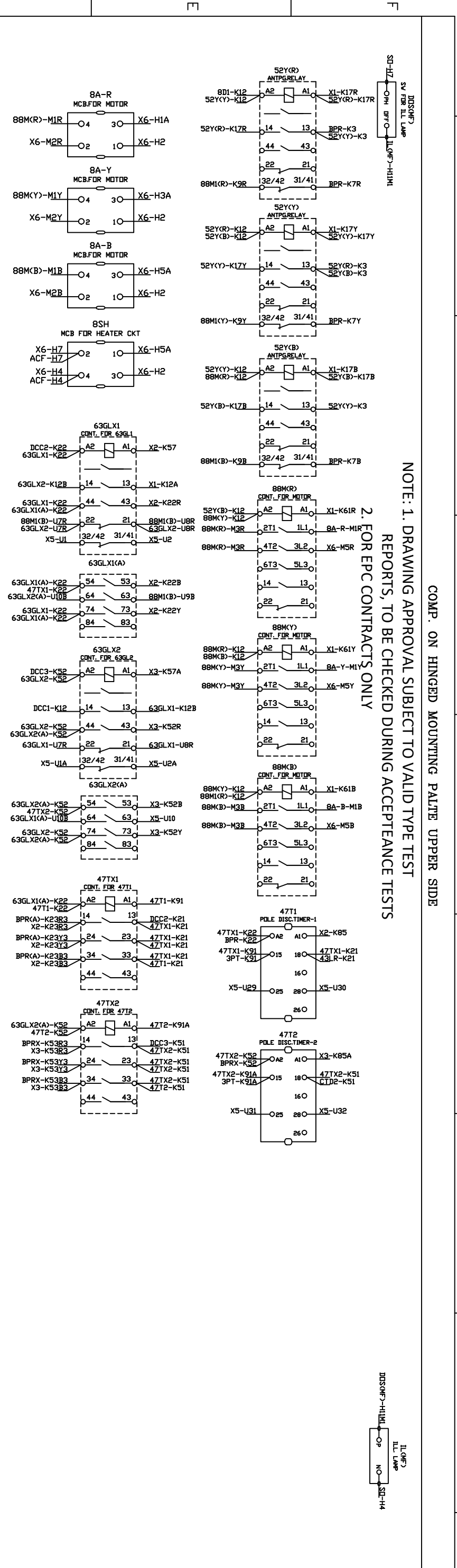
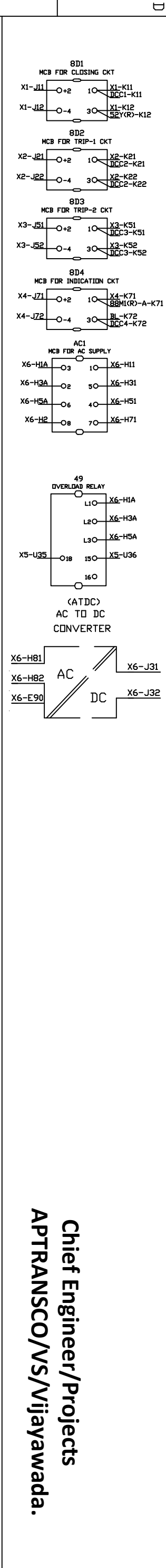
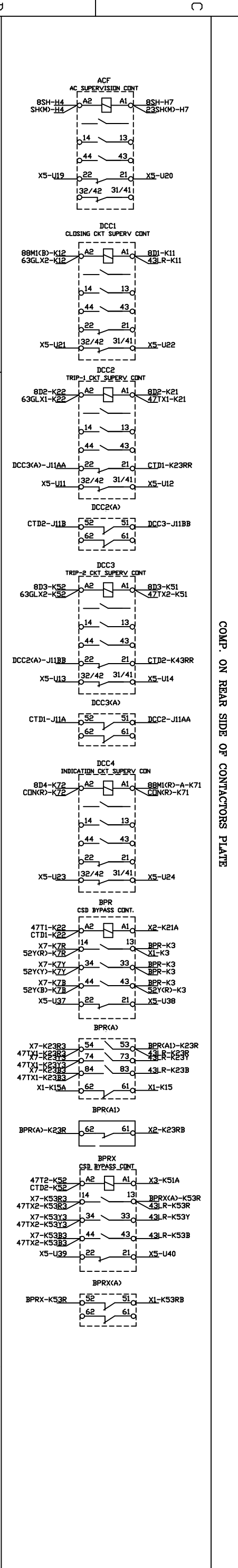
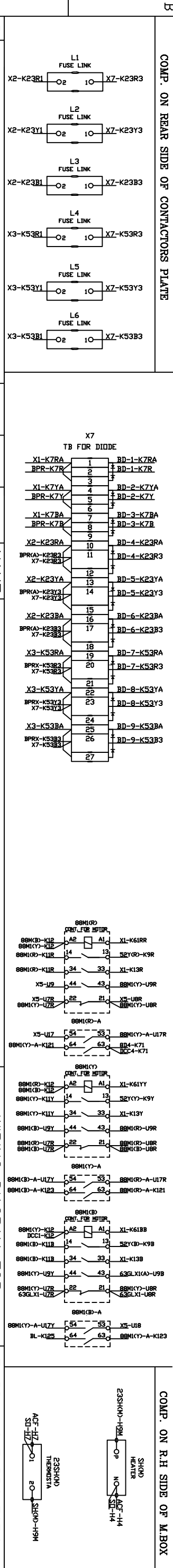

NOTE: 1. DRAWING APPROVAL SUBJECT TO VALID TYPE TEST REPORTS, TO BE CHECKED DURING ACCEPTANCE TESTS
2. FOR EPC CONTRACTS ONLY

Chief Engineer/Projects
APTTRANSCO/VS/Vijayawada.

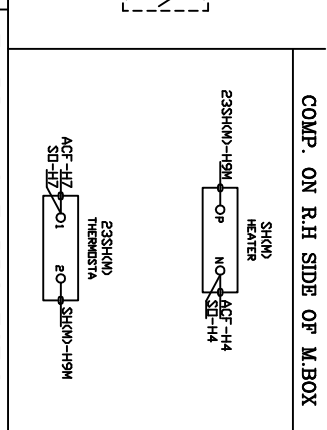

TITLE: WIRING DIAGRAM FOR M BOX CONTACTOR PLATE
FOR: 420KV, 63 KA, SP SPR
GCB TYPE: 400-SFM-60AA
DRG.NO.:CG-420CSD-25MM-WIR

CG Power and Industrial Solutions Limited
SINGHDEVI DIVISION SAAMBA, NASHIK

IF IN DOUBT ASK!

NO	REVISION	NAME	DATE	SCALE	ALL DIMENSIONS ARE IN mm
1					
2					
3					
4					
5					
6					
7					
8					
9					
10					
11					
12					
13					
14					
15					
16					
17					
18					
19					
20					
21					
22					
23					
24					
25					
26					
27					
28					
29					
30					
31					
32					
33					
34					
35					
36					
37					
38					
39					
40					
41					
42					
43					
44					
45					
46					
47					
48					
49					
50					

COMP. ON REAR SIDE OF CONTROL PANEL

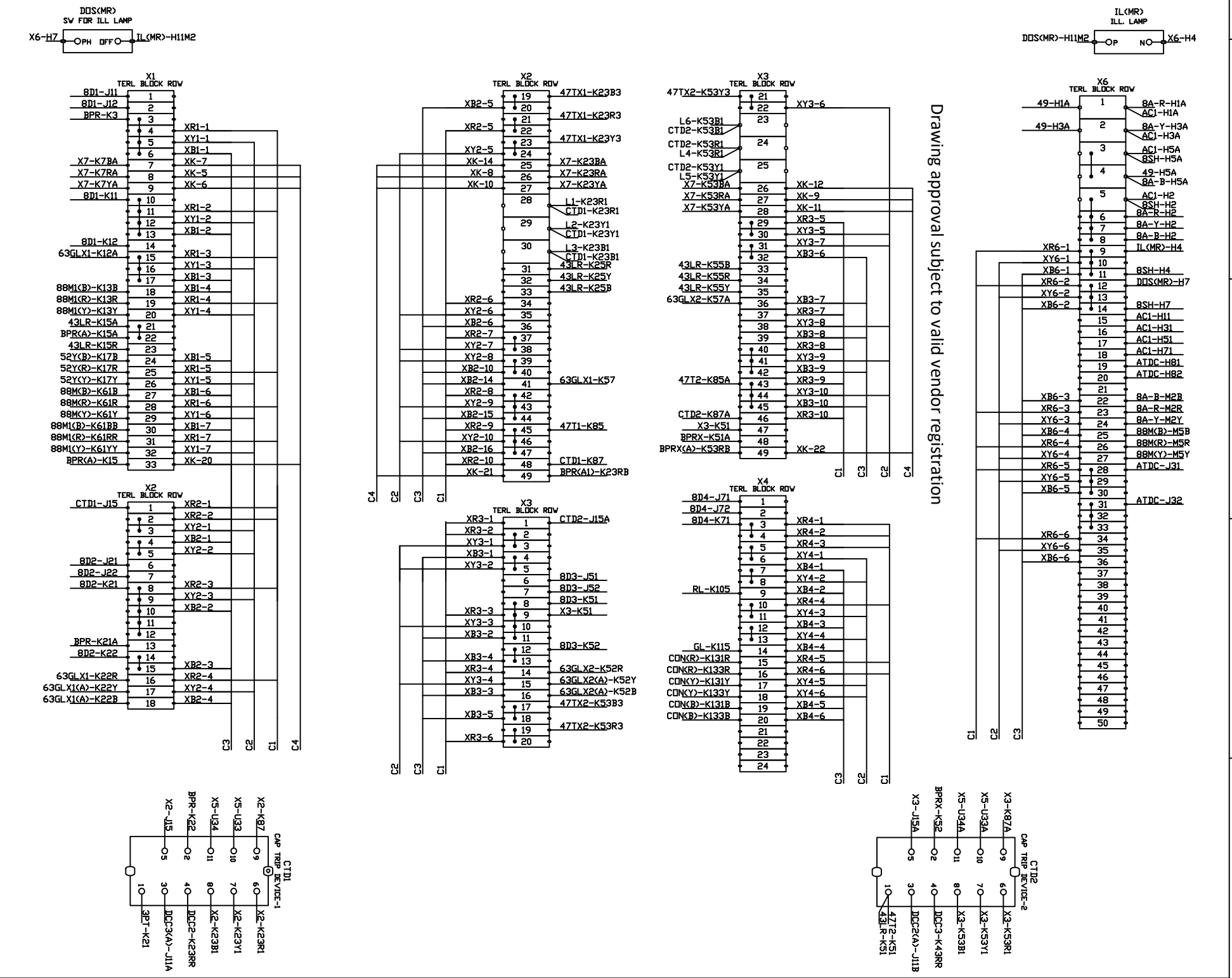

Drawing approval subject to valid vendor registration

COMP. ON FRONT SIDE OF CONTROL PANEL

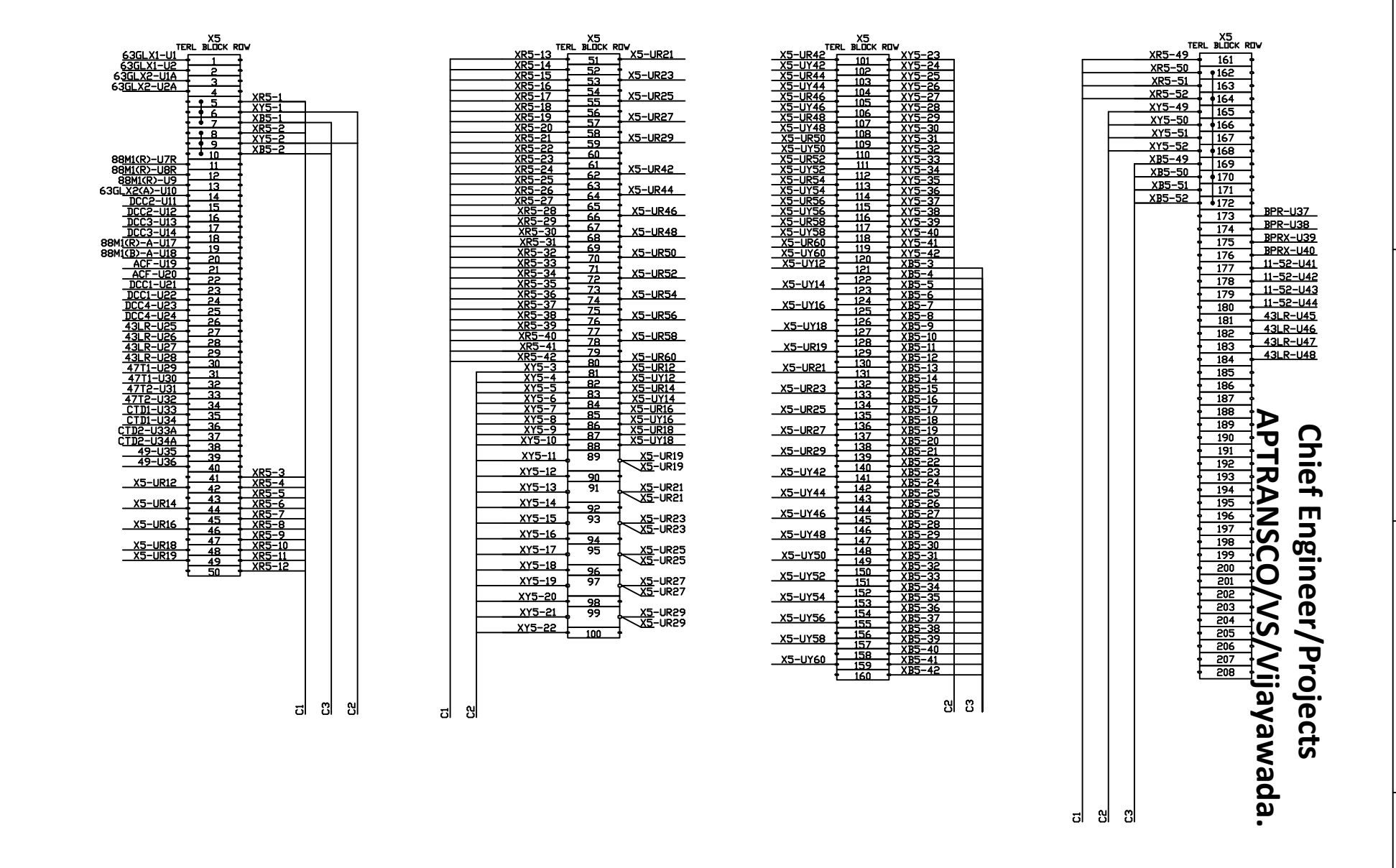

Chief Engineer/Projects
 APTRANSCO/VS/Vijayawada.

TITLE: WIRING DIAGRAM FOR	THIRD ANGLE PROJECTION
M BOX TERL BLOCK PLATE	
FOR: 420KV, 63 KA, SP SPR	
GCB TYPE: 400-SFM-60AA	
DRG.NO.:CG-420CSD-25MM-WIR	
CG Power and Industrial Solutions Limited	
SMITHCHIEF DIVISION SA/AM/AD, NS/SH/IK	



IF IN DOUBT ASK!

COMPONENTS MECH. HOUSING REAR OF HSG

COMPONENTS ON AUX SW MTG PLATE

NOTE: 1. DRAWING APPROVAL SUBJECT TO VALID TYPE TEST REPORTS, TO BE CHECKED DURING ACCEPTANCE TESTS
2. FOR EPC CONTRACTS ONLY

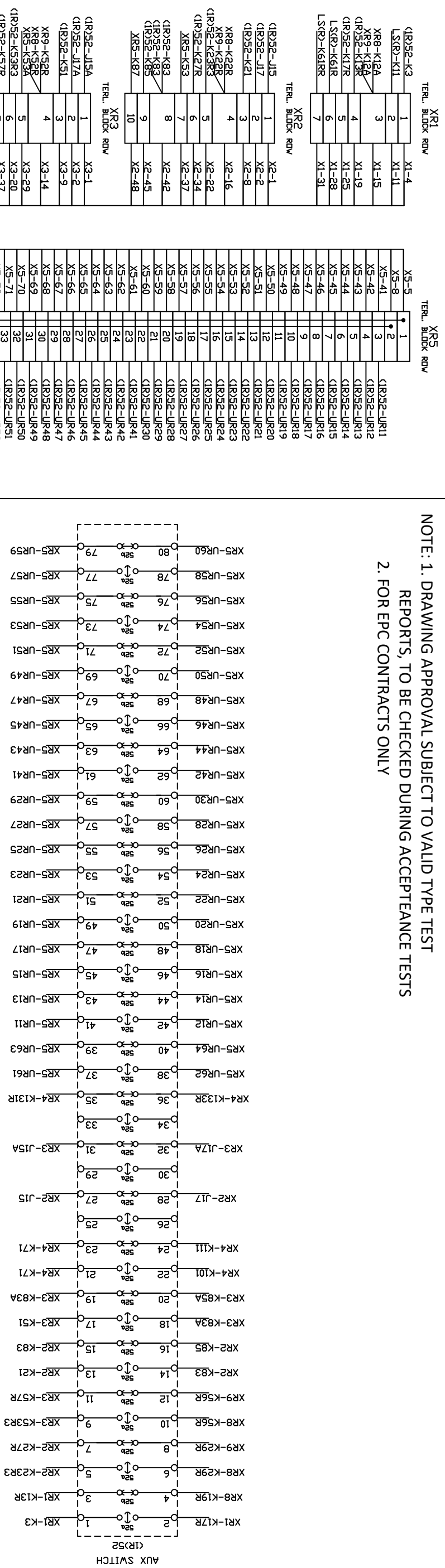

Chief Engineer/Projects
APTRANSCO/Vs/Vijayawada.

1. Minimum 300mm plinth shall be maintained for CT/PT/CVT/Isolators/IV/LA/Breakers in the Substation during foundation works to ensure safe live to ground clearance as per IE rules.
2. Since the supply of terminal connectors is not in the scope of manufacturer as mentioned in the drawings. The EPC contractor shall be instructed to supply the same in line with CT/PT/CVT/Isolator/IVT/LA/Breakers requirement and compatibility.

COMP. ON PR. SW. MTG. PLATE

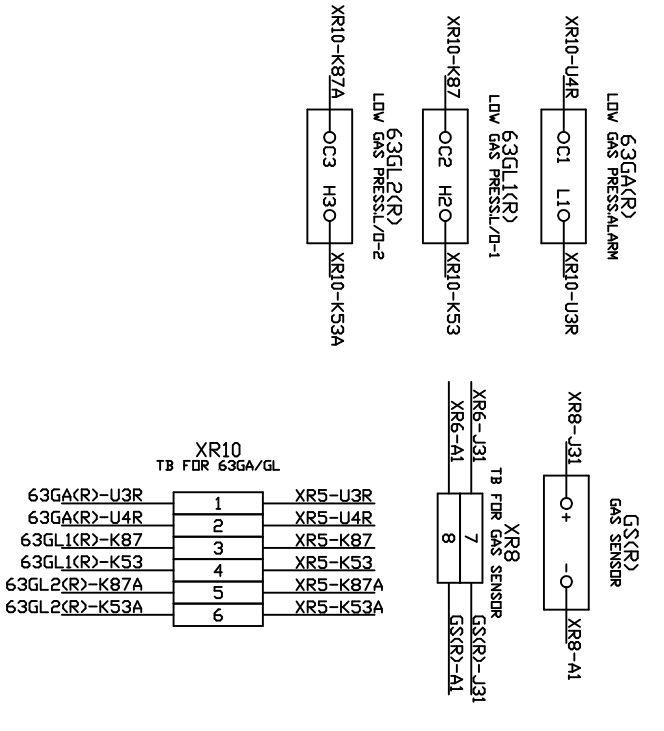

COMPONENTS ON MECH HSG

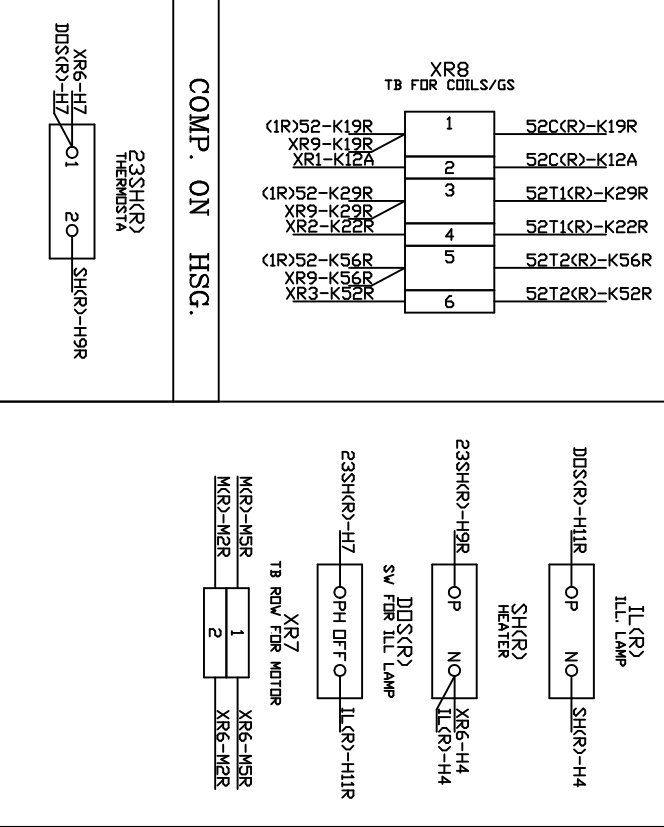

COMP. ON MECH FRAME

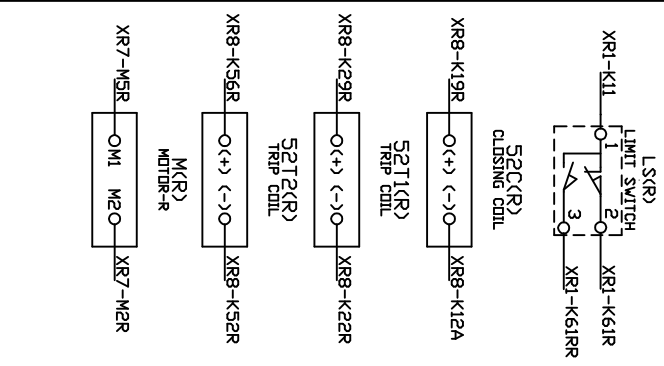

Drawing approval subject to valid vendor registration

NAME CUSTOMER: APTRANSCO

TITLE: WIRING DIAGRAM FOR MECH HSG PHASE-R

THIRD ANGLE PROJECTION

NO	REVISION	NAME	DATE	DATE: 13.03.24	ALL DIMENSIONS ARE IN mm	DRG.NO.:CG-420CSD-25MM-WIR
1						
2						
3						
4						
5						
6						
7						
8						
9						
10						

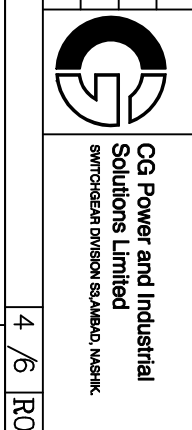

IF IN DOUBT ASK!

COMPONENTS MECH. HOUSING REAR OF HSG

COMPONENTS ON AUX SW MTG PLATE

NOTE: 1. DRAWING APPROVAL SUBJECT TO VALID TYPE TEST REPORTS, TO BE CHECKED DURING ACCEPTANCE TESTS
2. FOR EPC CONTRACTS ONLY

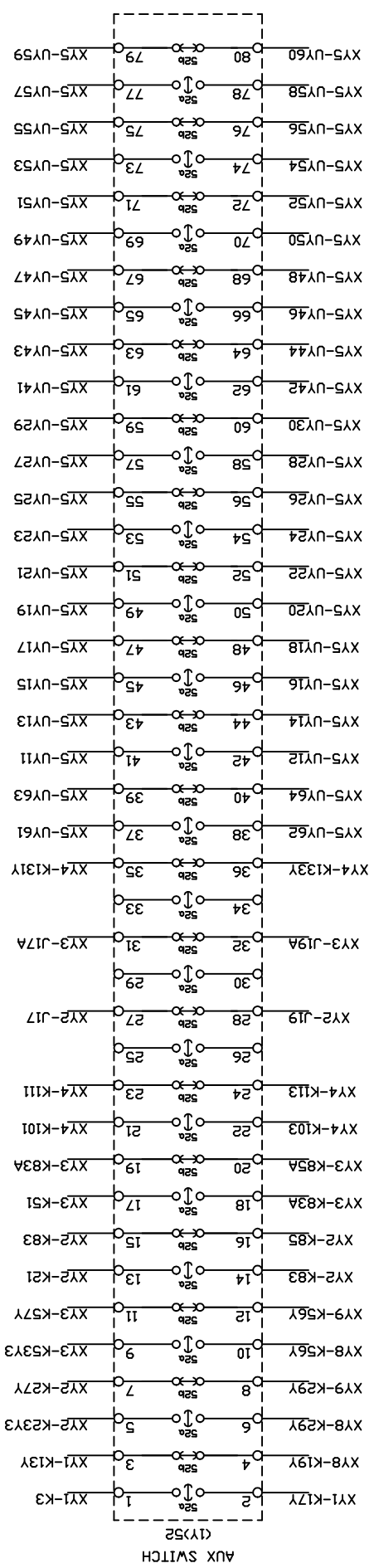

1. Minimum 300mm plinth shall be maintained for CT/PT/CVT/Isolators/V/LA/Breakers in the Substation during foundation works to ensure safe live to ground clearance as per IE rules.
2. Since the supply of terminal connectors is not in the scope of manufacturer as mentioned in the drawings. The EPC contractor shall be instructed to supply the same in line with CT/PT/CVT/Isolator/V/LA/Breakers requirement and compatibility.

Chief Engineer/Projects
APTRANSCO/VS/Vijayawada.

COMP. ON PR. SW. MTG. PLATE

COMPONENTS ON MECH HSG

COMPO ON MECH FRAME

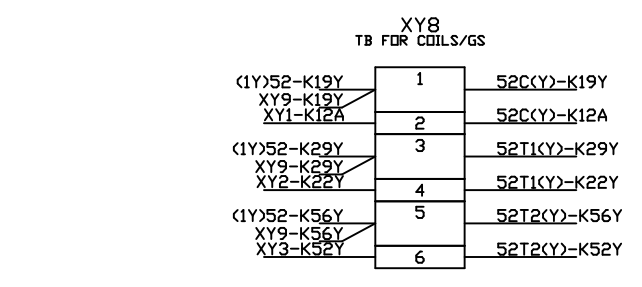
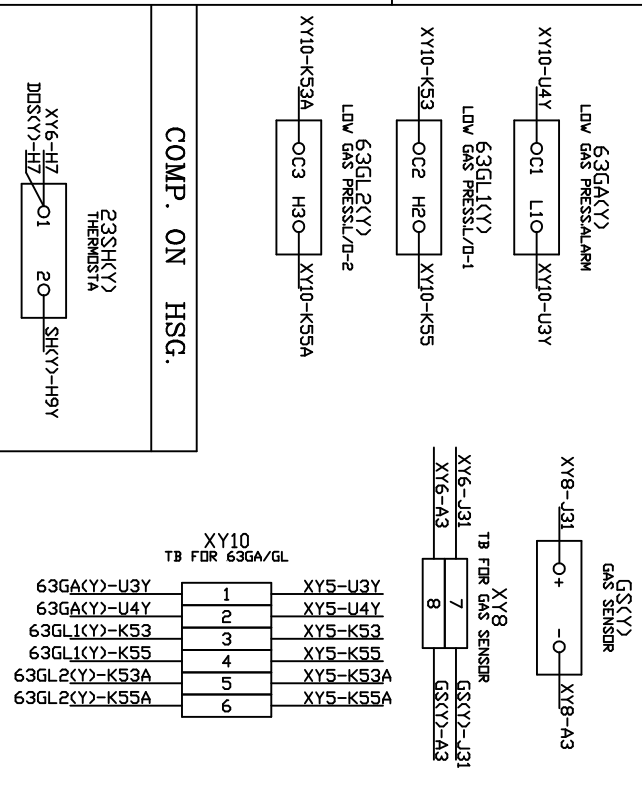
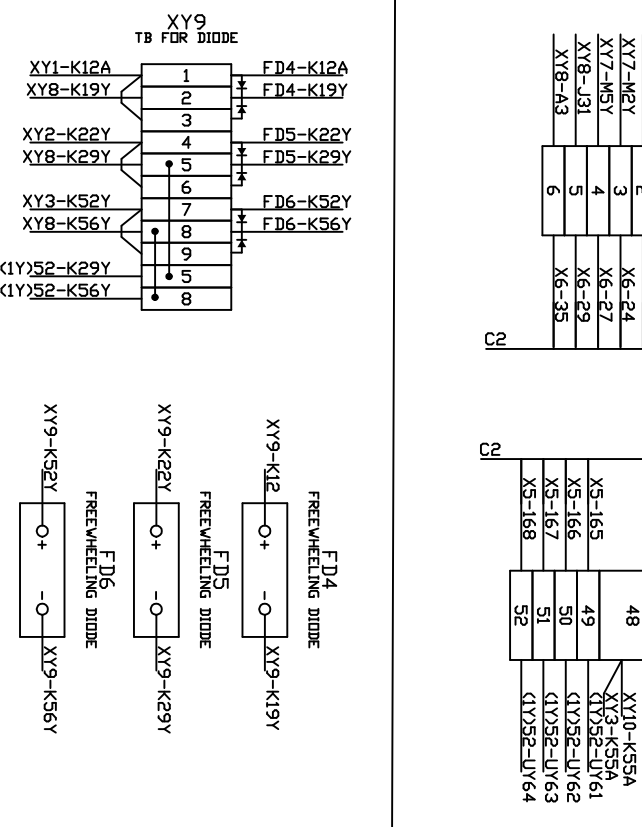

NO	REVISION	NAME	DATE	CUSTOMER	APPROVAL	SCALE	DATE	TITLE	THIRD ANGLE PROJECTION
1				APTRANSCO	DRN	N.T.S.	13.03.24	MECH HSG PHASE-Y	CG Power and Industrial Solutions Limited
2					NSR			FOR: 420KV, 63 KA, SP SPR	Solutions Limited
3					GNP			GCB TYPE: 400-SFM-60AA	SWITCHGEAR DIVISION SA/AMAD, NASHIK
4									
5									

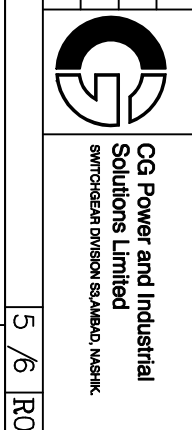

IF IN DOUBT ASK!

COMPONENTS MECH. HOUSING REAR OF HSG

COMPONENTS ON AUX SW MTG PLATE

NOTE: 1. DRAWING APPROVAL SUBJECT TO VALID TYPE TEST REPORTS, TO BE CHECKED DURING ACCEPTANCE TESTS
2. FOR EPC CONTRACTS ONLY

1. Minimum 300mm plinth shall be maintained for CT/PT/CVT/Isolator/s/V/LA/Breakers in the Substation during foundation works to ensure safe live to ground clearance as per I.E rules.
2. Since the supply of terminal connectors is not in the scope of manufacturer as mentioned in the drawings. The EPC contractor shall be instructed to supply the same in line with CT/PT/CVT/Isolator/V/LA/Breakers requirement and compatibility.

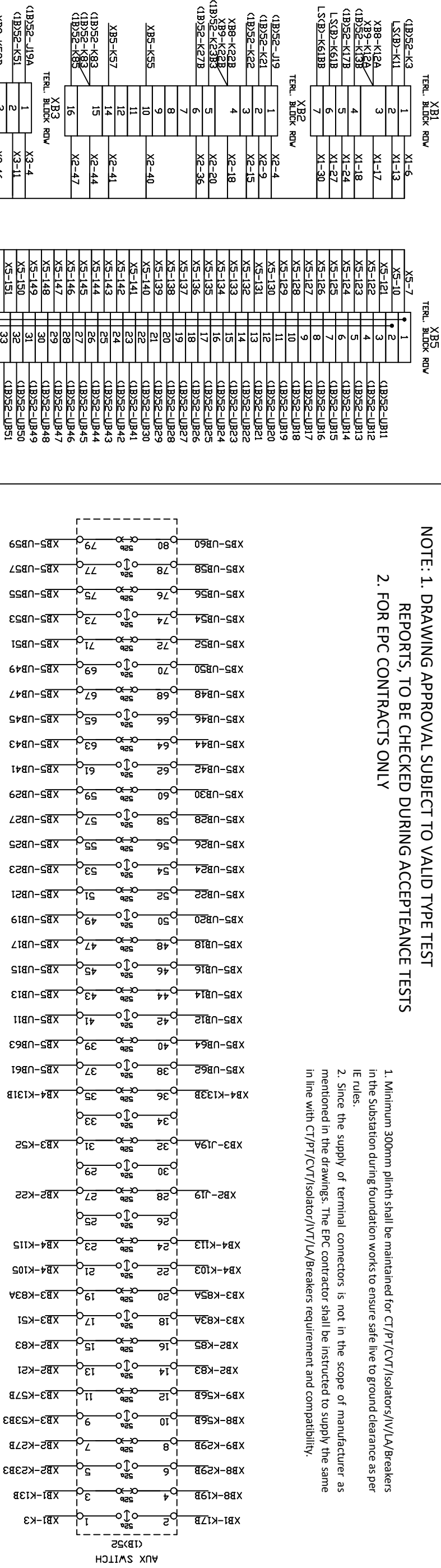

Chief Engineer/Projects
APTRANSCO/VS/Vijayawada.

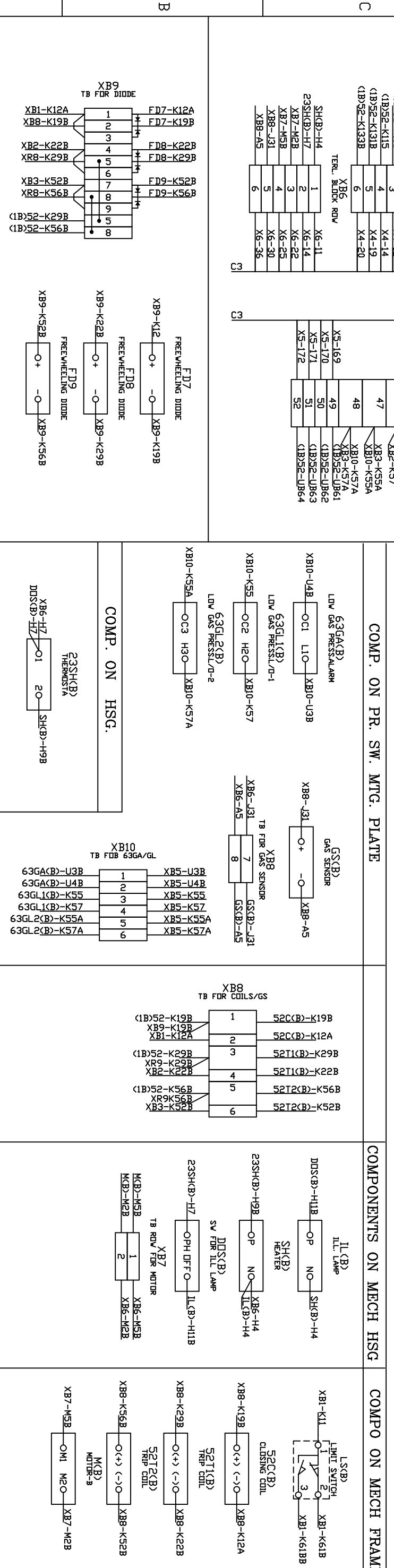

NO	REVISION	NAME	DATE	DATE:13.03.24	ALL DIMENSIONS ARE IN mm	DRG.NO.:CG-420CSD-25MM-WIR
1						
2						
3						
4						
5						

TITLE: WIRING DIAGRAM FOR
MECH HSG PHASE-B

FOR: 420KV, 63 KA, SP SPR

GCB TYPE: 400-SFM-60AA

THIRD ANGLE PROJECTION

CG Power and Industrial Solutions Limited
SINGHDEVI DIVISION SAAMBAO, NASHIK

IF IN DOUBT ASK!

NOTE: 1. DRAWING APPROVAL SUBJECT TO VALID TYPE TEST REPORTS, TO BE CHECKED DURING ACCEPTANCE TESTS
2. FOR EPC CONTRACTS ONLY

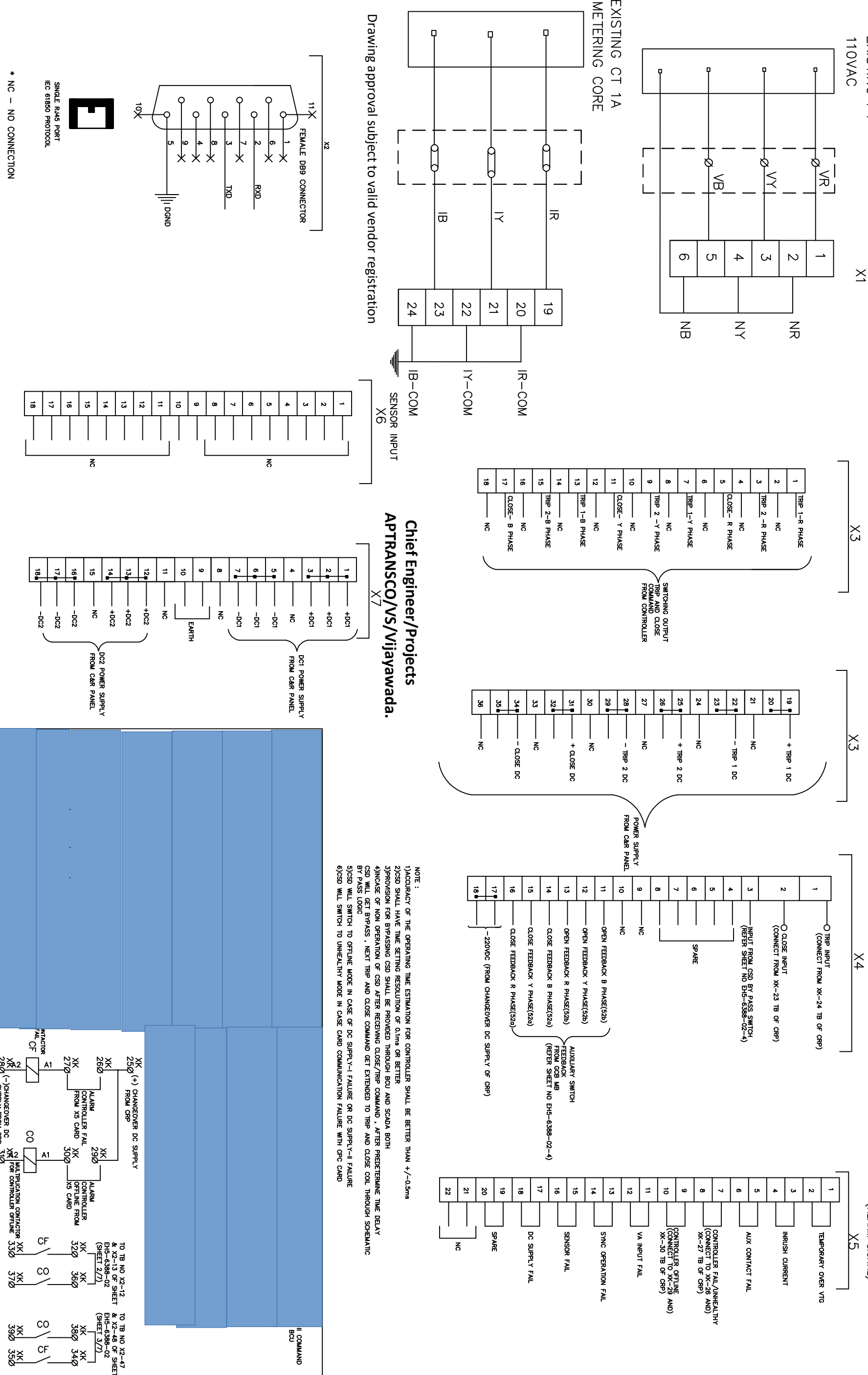

Drawing approval subject to valid vendor registration

Chief Engineer/Projects
APTRANSCO/VS/Vijayawada.

- NOTE :
- 1)ACCURACY OF THE OPERATING TIME ESTIMATION FOR CONTROLLER SHALL BE BETTER THAN +/-0.5ms
 - 2)CSD SHALL HAVE TIME SETTING RESOLUTION OF 0.1ms OR BETTER
 - 3)PROVISION FOR BYPASSING CSD SHALL BE PROVIDED THROUGH BCU AND SCADA BOTH
 - 4)IN CASE OF NON OPERATION OF CSD AFTER RECEIVING CLOSE/TRIP COMMAND , AFTER PREDETERMINE TIME DELAY CSD WILL GET BYPASS , NEXT TRIP AND CLOSE COMMAND GET EXTENDED TO TRIP AND CLOSE COIL THROUGH SCHEMATIC BY PASS LOGIC
 - 5)CSD WILL SWITCH TO OFFLINE MODE IN CASE OF DC SUPPLY-I FAILURE OR DC SUPPLY-II FAILURE
 - 6)CSD WILL SWITCH TO UNHEALTHY MODE IN CASE CARD COMMUNICATION FAILURE WITH CRC CARD

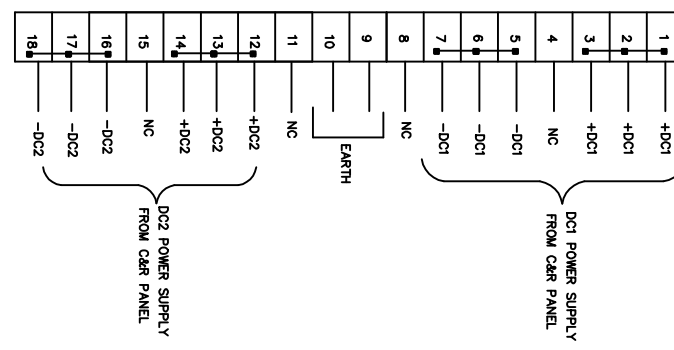
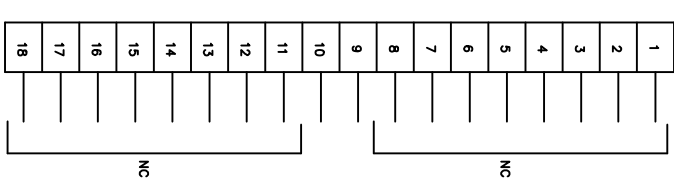
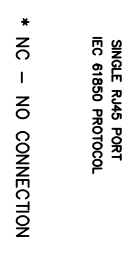

NO	REVISION	2	NAME	DATE	DATE:13.03.24	ALL DIMENSIONS ARE IN mm
1						
2						
3						
4						
5						

NAME	DRN	CHD	APPD	SCALE: N.T.S.
CUSTOMER: APTRANSCO	NSR	NSR	GNP	
STD APPROVAL 25MM/KV CREEPAGE WITH CSD				
TITLE: CSD GA AND TERMINAL DIAGRAM				
FOR: 420KV, 63 KA, SP SPR				
GCB TYPE: 400-SFM-60AA				
DRG.NO:CG-420CSD-25MM-CSD				

THIRD ANGLE PROJECTION

TO TB NO X2-12 & X2-13 OF SHEET EHS-6388-02 (SHEET 2/7)

TO TB NO X2-47 & X2-48 OF SHEET EHS-6388-02 (SHEET 3/7)

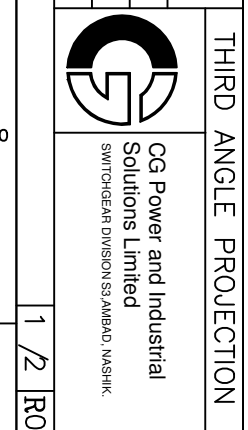

IF IN DOUBT ASK!

SYNC INTELLECT FRONT VIEW

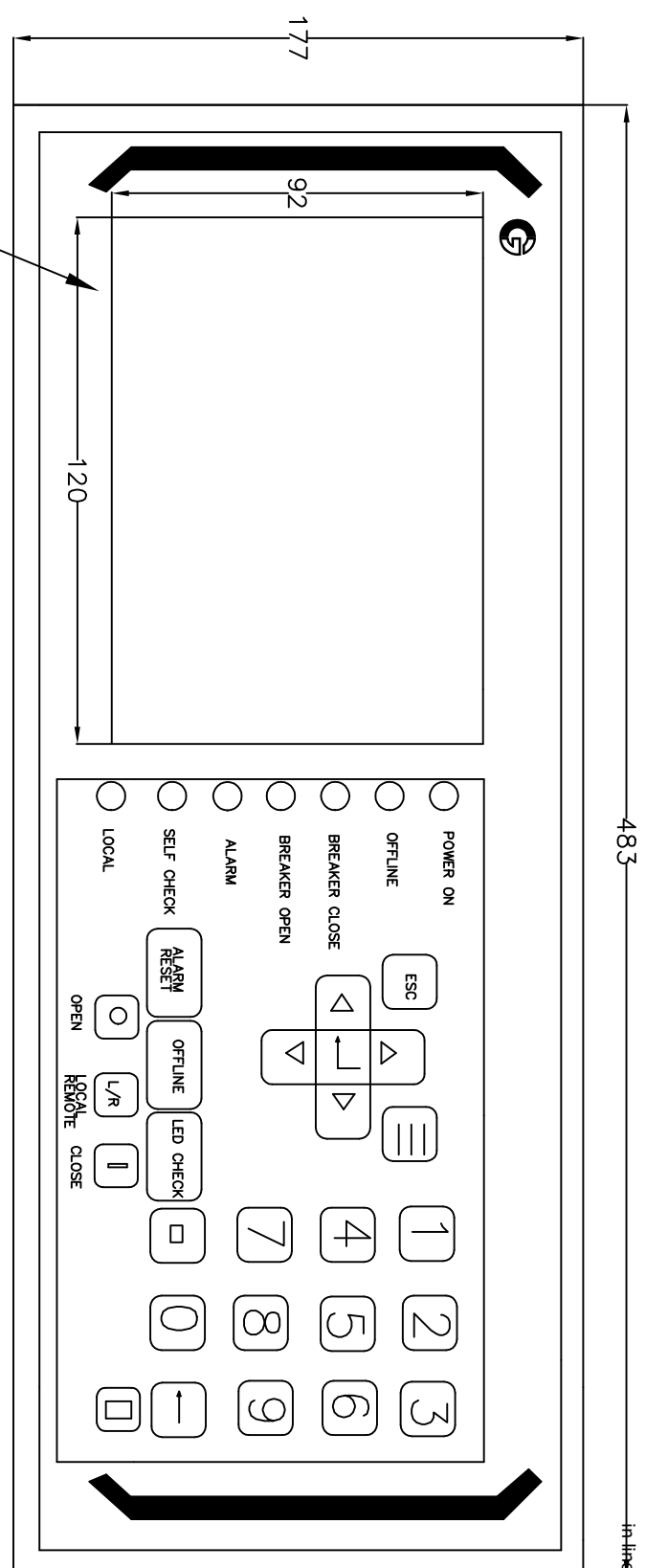

1. Minimum 300mm plinth shall be maintained for CT/PT/CVT/Isolators/IV/LA/Breakers in the Substation during foundation works to ensure safe live to ground clearance as per IE rules.
2. Since the supply of terminal connectors is not in the scope of manufacturer as mentioned in the drawings. The EPC contractor shall be instructed to supply the same in line with CT/PT/CVT/Isolator/IVT/LA/Breakers requirement and compatibility.

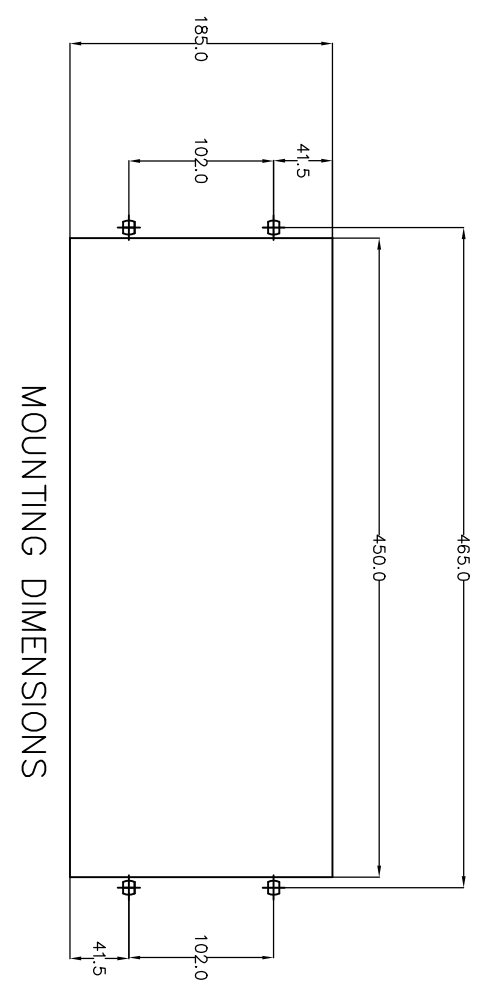

TECHNICAL DETAILS ARE MENTIONED IN USER MANUAL
MOUNTING : 19 INCH RACK MOUNTED

SYNC INTELLECT REAR VIEW

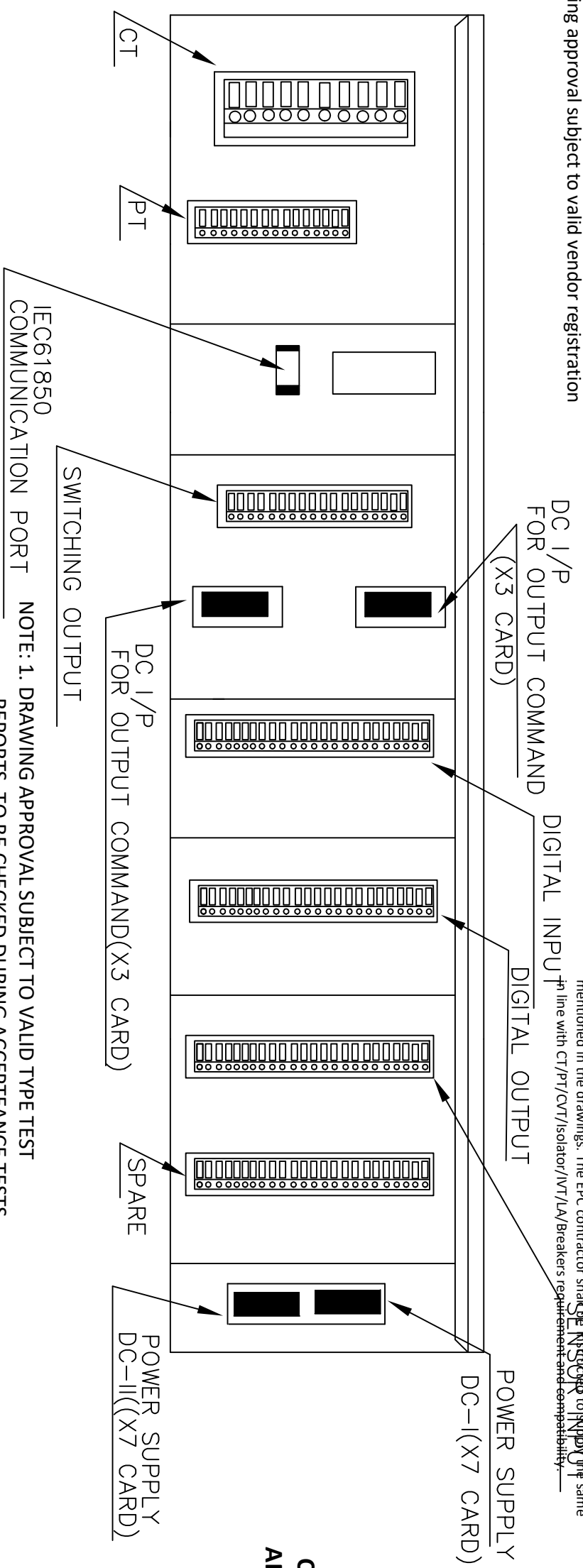

1. Minimum 300mm plinth shall be maintained for CT/PT/CVT/Isolators/IV/LA/Breakers in the Substation during foundation works to ensure safe live to ground clearance as per IE rules.
2. Since the supply of terminal connectors is not in the scope of manufacturer as mentioned in the drawings. The EPC contractor shall be instructed to supply the same in line with CT/PT/CVT/Isolator/IVT/LA/Breakers requirement and compatibility.

Chief Engineer/Projects
APTRANSCO/VS/Vijawada.

NO	REVISION	NAME	DATE	ALL DIMENSIONS ARE IN mm	DRG.NO.:CG-420CSD-25MM-CSD
1					
2					
3					
4					
5					

NAME	DATE	NAME	DATE
DRN	RSB	CHD	NSR
APPD	GNP	SCALE:	N.T.S.

TITLE:	CSD GA AND TERMINAL DIAGRAM
FOR:	420KV, 63 KA, SP SPR
GCB TYPE:	400-SFM-60AA

NAME	CUSTOMER: APTRANSCO
DRN	STD APPROVAL 25MM/KV CREEPAGE WITH CSD
APPD	GNP

THIRD ANGLE PROJECTION

NOTE: 1. DRAWING APPROVAL SUBJECT TO VALID TYPE TEST REPORTS, TO BE CHECKED DURING ACCEPTANCE TESTS
2. FOR EPC CONTRACTS ONLY

CG Power and Industrial Solutions Limited
SWITCHEAR DIVISION SANGHVI NASHIK