

NOTE : DRAWING APPROVAL SUBJECT TO VALID TYPE TEST REPORTS, TO BE

CHECKED DURING ACCEPTANCE TESTS. ANNEXURE – I

SHEET No.: 1 OF 7

GUARANTEED TECHNICAL PARTICULARS FOR 33 KV OIL IMMERSSED CURRENT TRANSFORMERS

CTR : 1600-1200-800/1-1-1-1AMPs. (BAR PRIMARY)

01.	Type of tank/Installation	Live tank/Outdoor			
02.	Manufacturer's Name and address and Country of Manufacture	Vishal Transformers & Switchgears Pvt. Ltd., Rithani, Delhi Road, Meerut – 250 103, INDIA			
03.	Conforming to standard	IS: 16227:2016			
04.	Rated voltage/ highest voltage (KV rms)	33/36			
05.	Rated primary current (A)	1600-1200-800			
06.	Rated secondary current (A)	1 A			
07.	Ratio taps (on secondary side only)	On secondary side only			
08.	Type of insulation	A			
09.	Primary Stud/ Secondary Stud	Electrolytic Copper stud of 50 mm diameter X 115mm Length / M6 Nickle plated brass			
10.	Partial Discharge level	< 10 pc at Um < 5 pc at 1.2 Um/√3			
11.	Thickness of the matel tank	5mm top & bottom. 3.15mm tank side			
12.	Tank material and Tank coating	M.S/SS With paint shade 631 of IS-5			
13.	Hardware exposed to atmosphere	SS			
	Sealing arrangement(gasket & groove)	1. Insulator interfaces at top and base trolly using gasket. 2. Secondary terminals epoxy moulded block interfaces using gasket 3. Oil level indicator and primary stud interfaces with tank using gasket.			
14.	Porcelain housing and it's make (Single piece only as per clause 3.1.2)	Condenser type hollow insulator, CJI/ Genesis Make or any other standard make with cemented flange			
15.	Rated continuous thermal current	1.2 times continuous			
16.	Temperature rise over ambient	<50deg.centigrade			
17.	O-RING AND GASKETS	Nitrile Butyl Rubber			
18.	Acceptable limit of temperature	95 deg. C			
19.	Whether CT is hermetically sealed	yes			
20.	Rated short time withstand current for 1 sec. Duration (KA rms)	25			
21.	Rated dynamic withstand current (KAP)	62.5			
22.	Current density at STC Rating	<180 A/ sq.mm			
23.	1.2/50 micro second Impulse withstand voltage (KVP)	170			
24.	One minute power frequency withstand voltage (KV rms) of primary winding (Dry)	70 Drawing approval subject to valid vendor registration			
25.	One minute power frequency withstand voltage of secondary winding (KV rms)	3			
26.	a) Minimum total creepage distance of insulator bushing (mm) b) Protected creepage of distance of bushing (mm)	900 400 Chief Engineer Power Systems, Planning & Design APTransco			
27.	Details of Core Core No.	Core-I ProtectionI	Core-II Diff. Protection	Core-III Metering	Core- IV Metering
27.1	Current Ratios A/A	1600-1200-800/1	1600-1200-800/1	1600-1200-800/1	1600-1200-800/1
27.2	Output burden (VA)	15	-	15	5
27.3	Class of accuracy	5P	PX	0.2S	0.2S

FOR EPC CONTRACTS ONLY

				SHEET No.: 2 OF 7	
27.4	Instument Security Factor (ISF)			<5@ All ratio	
27.5	Accuracy limit factor	10	-	-	-
27.6	Min. knee point voltage (kpv) at all ratio	-	40I(RCT+10)	-	-
27.7	Exciting current (I _{ext})	-	<30mA at 1600 A, <40 mA at 1200 A, <50 mA at 800A	-	-
28	Weight of oil (Kg.)	25 ±2(Approx.)			
29.	Weight of steel	34 Kgs (Approx)			
30.	Weight of copper	18 Kgs (Approx.)			
31.	Mounting details	400mmx 400mm.+/-2			
32.	Overall dimensions	As per GA Drawing			
33	Whether all O-rings/ gasket are fixed in grooves	yes			

Vishal Transformers & Switchgears (P) Ltd

(V.S. Negi)
G.M. (Marketing)

Chief Engineer
Power Systems, Planning & Design
APTransco

NOTE : DRAWING APPROVAL SUBJECT TO VALID TYPE TEST REPORTS, TO BE CHECKED DURING ACCEPTANCE TESTS.

FOR EPC CONTRACTS ONLY

NOTE: DRAWING APPROVAL SUBJECT TO VALID TYPE TEST REPORTS, TO BE

CHECKED DURING ACCEPTANCE TESTS,
(SHOWN IN SEPARATE DWG.)

BILL OF MATERIAL

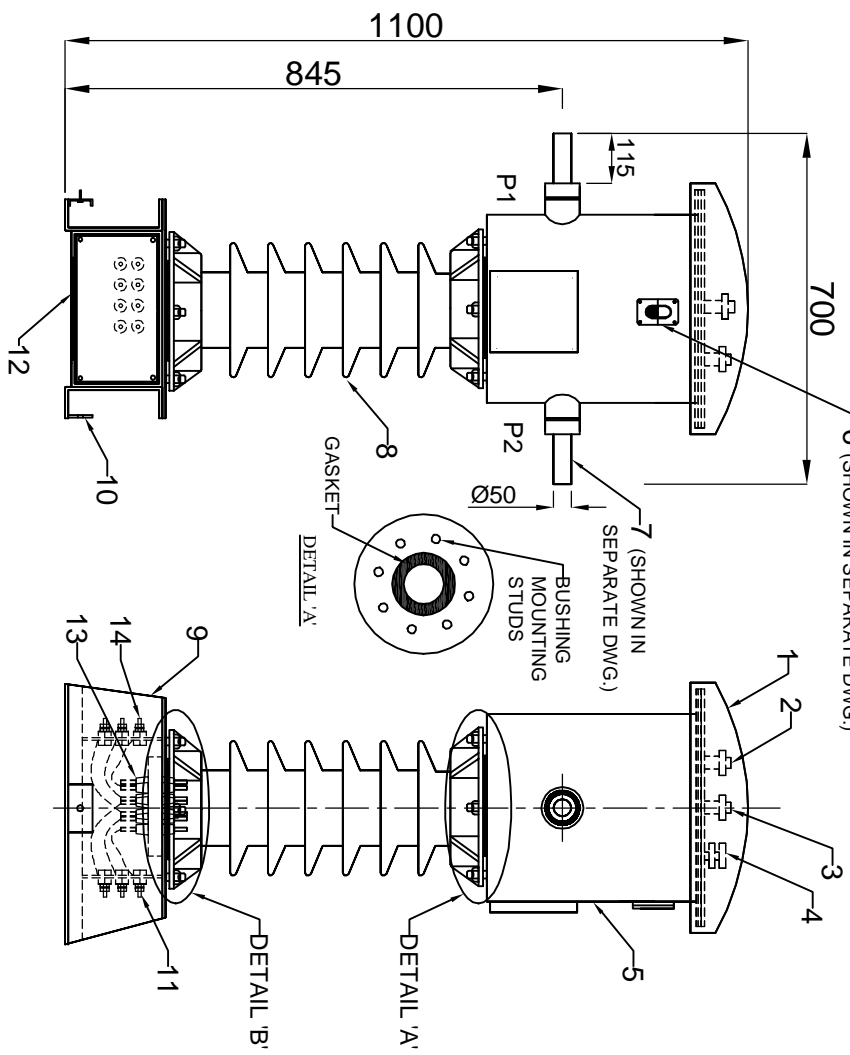

Drawing approval subject to valid vendor registration

S.No.	ITEM	MATE. / SPEC.	QTY.
1.	DOME SHAPE RAIN COVER	M.S.	1No.
2.	OIL FILLING PORT	M.S. (HDG)	1No.
3.	NITROGEN VALVE	M.S. (HDG) / BRASS	1No.
4.	PRESSURE RELIEF VALVE (SPRING TYPE)	BRASS	1No.
5.	MAIN TANK	M.S. / S.S.	1No.
6.	OIL LEVEL INDICATOR	ALUMINIUM & GLASS	1No.
7.	PRIMARY TERMINAL	TINNED COPPER Ø50mm x 115mm LENGTH PORCELAIN/GENESIS/ JAI PUR GLASS/ EOL.	2Nos.
8.	H.T. BUSHING WITH CEMENTED FLANGE	M.S.	1No.
9.	MOUNTING BASE	M.S.	1No.
10.	EARTHING PAD	M.S., 50 x 8 x 60(L)mm	2Nos.
11.	SECONDARY TERMINAL BOX (FOR CORE I & II)	NICKELLED BRASS, M6	1No.
12.	REMOVABLE GLAND PLATE WITHOUT HOLE	M.S.	2Nos.
13.	SECONDARY TERMINAL PLATE	EPOXY RESIN WITH NICKELLED BRASS STUDS / TEFLON WIRES	1No.
14.	SECONDARY TERMINAL BOX (FOR CORE III & IV) WITH SEPARATOR	NICKELLED BRASS, M6	2Nos.

NOTE :-

1. CREEPAGE DISTANCE OF H.T. BUSHING :- 900 mm (MIN).
2. TANK SHALL BE PAINTED WITH MIN 2-COATS OF ZINC RICH EPOXY PRIMER & ONE COAT OF PU PAINT SHADE NO.- 631 OF IS : 5 EXTERNALLY.
3. THE INNER SURFACE SHALL BE PAINTED WITH OIL RESISTANCE PAINT.
4. ALL HARDWARES EXPOSED TO ATMOSPHERE SHALL BE SS.
5. ALL GASKET SHALL BE MADE OF NITRILE BUTYL RUBBER & HOUSED IN PROPERLY MACHINED GROOVES.
6. DETAIL 'A' & 'B' : GASKET ARRANGEMENT IN MACHINED GROOVE FOR BUSHING MOUNTING ON BOTH SIDE.
7. METERING CORE (4th) SHALL BE PROVIDED IN SEPARATE SECONDARY BOX WITH SEALING ARRANGEMENT.

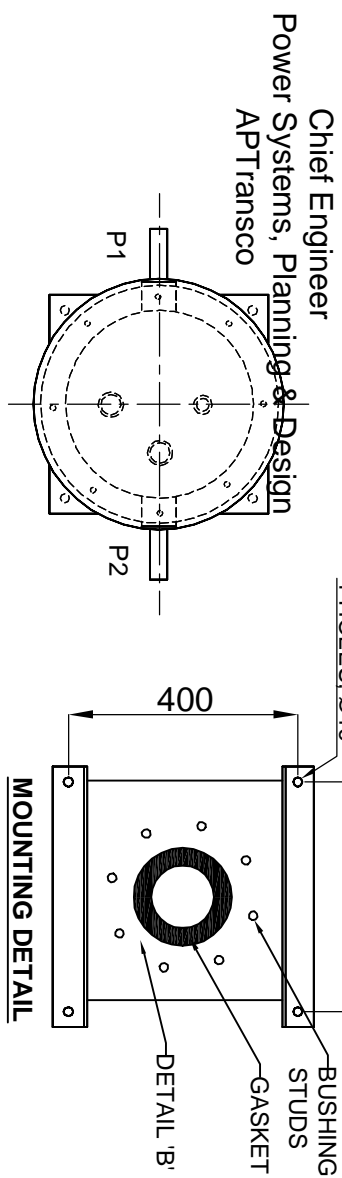

4-HOLE S. Ø16
BUSHING MOUNTING
STUDS
GASKET
DETAIL 'B'
MOUNTING DETAIL

VISHAL TRANSFORMERS & SWITCHGEARS (P) LTD.
RITWAN, DELHI ROAD, MEERUT U.P (INDIA)

SCALE	BOM NO.	NAME	SIGN.	DATE
N.T.S.		VISHESH		
		GAURAV		
		M.P.S.		

DRG. REF.

REV. NO.	DESCRIPTION	REV. BY	APPD. BY	DATE

TOLERANCE: ±10%
WEIGHT: 110±20 KG.

TITLE
GENERAL ARRANGEMENT DRAWING OF
33KV OIL IMMERSED CT (BAR PRIMARY)
(RATIO:1600-1200-800/1-1-1-1A)

DRAWING NO. :-
GA-013321-313

SHEET NO:- 3 OF 7

REV. 00

FOR EPC CONTRACTS ONLY

NOTE : DRAWING APPROVAL SUBJECT TO VALID TYPE TEST REPORTS, TO BE CHECKED DURING ACCEPTANCE TESTS.



33KV CURRENT TRANSFORMER

S.No.	MADE TO	IS-16227 : 2016
RATIO	BURDEN	15 / - / 15 / 5 VA
HSV / INS. LEVEL	ACC. CLASS	5P / PX / 0.2S / 0.2S
S.T.C.	A.L.F./S.F.	10 for PROT. < 5 at all ratio for MET.
I. Dyn.	Vk.(PS CORE)	> 40 I (Rct + 10) at all ratio
CLASS OF INS.	Rct.(PS CORE)	< 8 Ω at 800/1A < 12 Ω at 1200/1A < 16 Ω at 1600/1A
FREQUENCY	Iext.(PS CORE)	< 50mA at 800/1A < 40mA at 1200/1A < 30mA at 1600/1A
TYPE	TOTAL WEIGHT	110±20 Kg.
YEAR OF MFG.	PROP. OF	APTRANSKO
OIL QUANTITY	TYPE OF INSULATING OIL	IEC 60296
CONTINUOUS CURRENT RATING - 120 %	TEMPERATURE CATEGORY :	-5°C to 40°C
P.O. No.		
MFD. BY:	VISHAL TRANSFORMERS & SWITCHGEARS (P) LTD. MEERUT (INDIA) 250103	

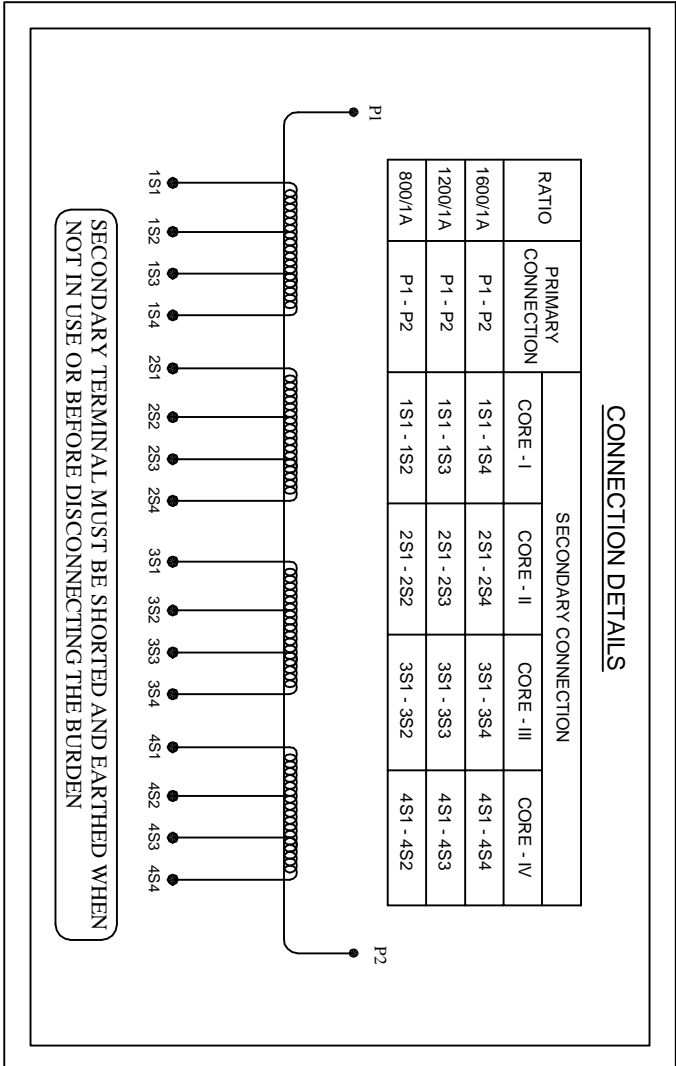

Chief Engineer
Power Systems, Planning & Design
APTransco

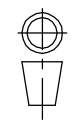

SCALE : N.T.S.
BOM NO. :

DRN.	VISHESH	NAME		SIGN.		DATE	
CHK.	GAURAV						
APPD.	M.P.S.						
DRG. REF.		GA-013321-313					

REV. NO.	DESCRIPTION	REV. BY	APPD. BY	DATE
TOLERANCE:-		WEIGHT:-		

TITLE
RATING & CIRCUIT DIAGRAM PLATE
CT RATIO : 1600-1200-800/1-1-1-1A (BAR PRIMARY)

DRAWING NO. :-
NP-013321-313

SHEET NO:- 4 OF 7

NOTE : DRAWING APPROVAL SUBJECT TO VALID TYPE TEST REPORTS, TO BE CHECKED DURING ACCEPTANCE TESTS.

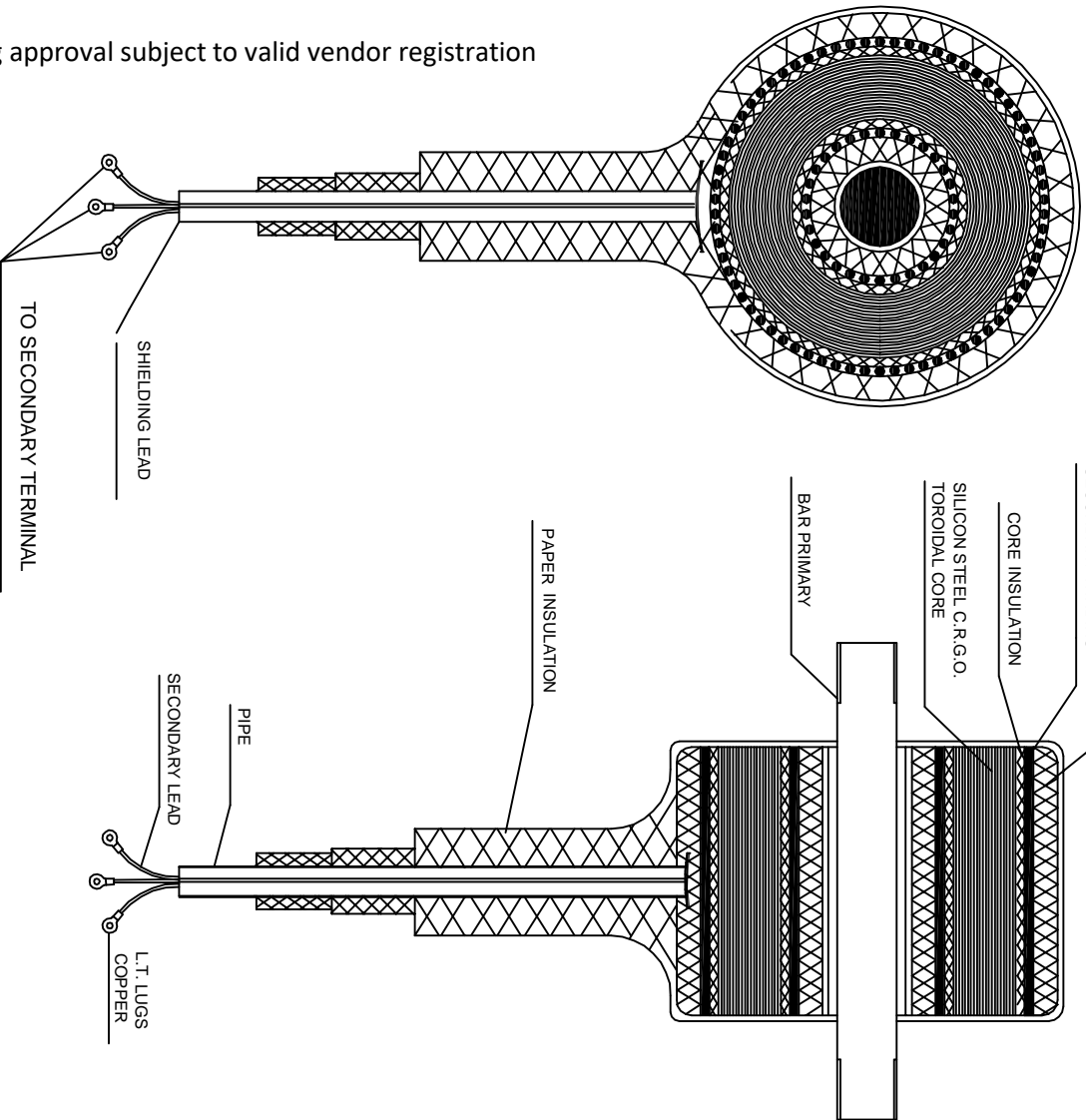

Drawing approval subject to valid vendor registration

Chief Engineer
Power Systems, Planning & Design
APTtransco

FOR EPC CONTRACTS ONLY

DESIGN DATA :

PRIMARY WINDING :

- 1) Area of cross section : 1962.5 Sqmm
- 2) No. of turns : Single (Bar Primary)
- 3) Conductor material : Electrolytic Copper
- 4) Weight of conductor : 12 Kgs approx

SECONDARY WINDING :

- 1) Area of cross section :
 Core-I : 20SWG (0.655Sqmm)
 Core-II : 18SWG (1.165Sqmm) 0 to 800 Turns, 21SWG (0.518Sqmm) 801 to 1600 Turns
 Core-III : 21SWG (0.518Sqmm)
 Core-IV : 21SWG (0.518Sqmm)
- 2) No. of secondary turns : 1600 with taps at 1200 & 800 Turns (For all cores)
- 3) Conductor material : Super enamel copper wire

VISHAL TRANSFORMERS & SWITCHGEARS (P) LTD.
 RTNANI, DELHI ROAD, MEERUT U.P (INDIA)



SCALE : N.T.S.
 BOM NO.

DRN.	NAME	SIGN.	DATE
CHK.	VISHESH GAURAV		
APPD.	M.P.S.		

DRG. REF.
 GA-013321-313

TITLE
SECTIONAL VIEW OF INTERNAL JOB FOR 33KV LT CT
CT RATIO : 1600-1200-800/1-1-1A (BAR TYPE)

DRAWING NO. :-
SEC-013321-313
 SHEET NO:- 5 OF 7
 REV. 00

REV. NO.	DESCRIPTION	REV. BY	APPD. BY	DATE

ALL DIMENSIONS ARE IN MM.

TOLERANCE:-

WEIGHT:-

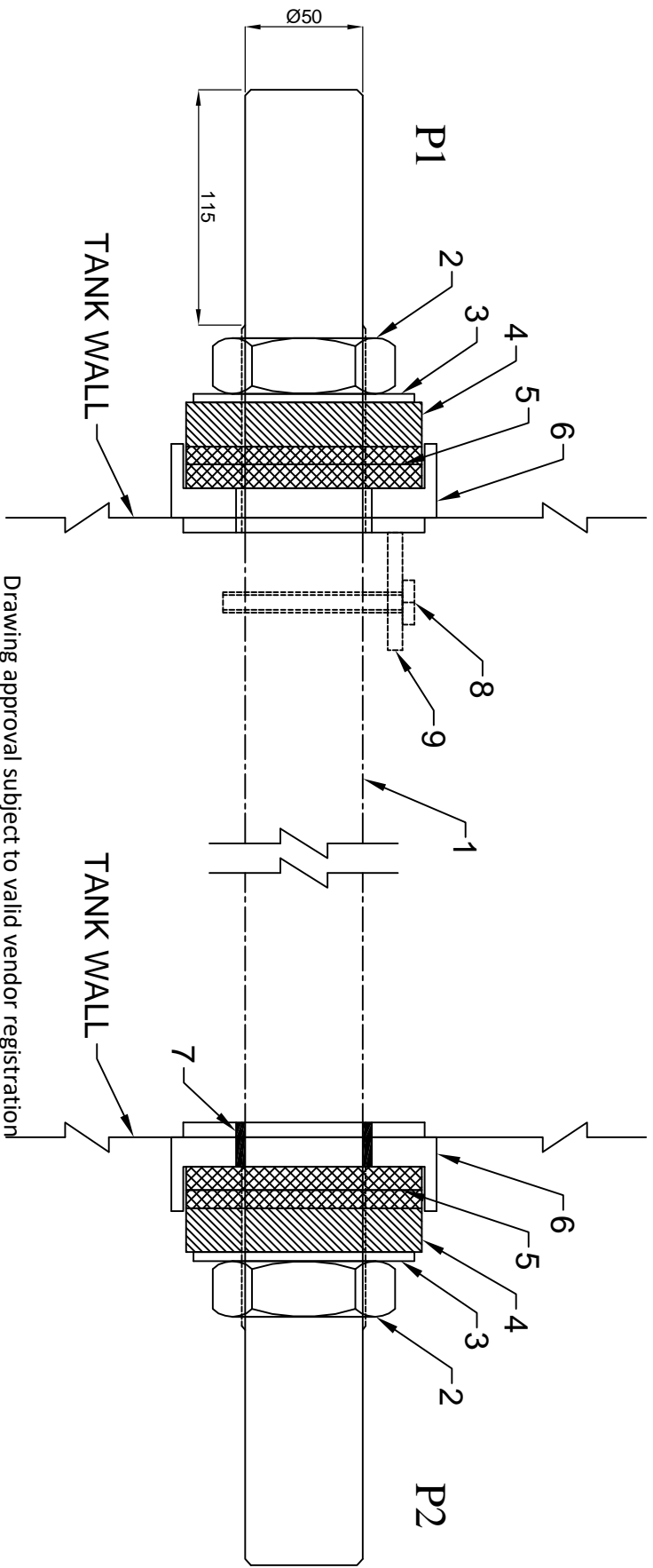

BILL OF MATERIAL

S.No.	ITEM	MATE. / SPEC.	QTY.
1.	PRIMARY (BAR TYPE)	TINNED COPPER	1 No.
2.	MAIN NUT	BRASS	1 No. EACH SIDE
3.	BRASS WASHER	BRASS TH.-3mm	1 No. EACH SIDE
4.	BUSHING WASHER	F.R.P.	1 No. EACH SIDE
5.	GASKET WASHER FOR OIL SEALING	NITRILE BUTYL RUBBER	2 Nos. EACH SIDE
6.	BUSH (WELDED WITH TANK)	M.S. / S.S.	1 No. EACH SIDE
7.	ISOLATING SLEEVE (ONLY ON P2 SIDE)	POLYESTER	1 No.
8.	PRIMARY ROD STOPPER PIN	M.S. (6mm dia)	1 No.
9.	STRIP WELDED WITH TANK (FOR HOLDING STOPPER PIN)	M.S.	1 No.

FOR EPC CONTRACTS ONLY

Drawing approval subject to valid vendor registration

Chief Engineer
 Power Systems, Planning & Design
 APTransco

NOTE : DRAWING APPROVAL SUBJECT TO VALID TYPE TEST REPORTS, TO BE CHECKED DURING ACCEPTANCE TESTS.

VISHAL TRANSFORMERS & SWITCHGEARS (P) LTD.
 RITHANI, DELHI ROAD, MEERUPT U.P (INDIA)

SCALE N.T.S.	BOM NO.	NAME VISHESH	SIGN.	DATE
		CHK. GAURAV		
		APPD. M.P.S.		
DRG. REF. GA-013321-313				

REV. NO.	DESCRIPTION	REV. BY	APPD. BY	DATE
TOLERANCE:-				

TITLE		DRAWING NO.:- PRI.TER.-50115	REV.
EMERGENCE OF PRIMARY TERMINAL FOR 33kV CT			
CT RATIO : 1600-1200-800/1-1-1A (BAR TYPE)		SHEET NO:- 6 OF 7	00

ALL DIMENSIONS ARE IN MM.

Drawing approval subject to valid vendor registration

BILL OF MATERIAL

S.No.	ITEM	MATE. / SPEC.	QTY.
1.	BASE PLATE (WELDED WITH TANK)	M.S.	1No.
2.	TOP PLATE	ALUMINIUM	1No.
3.	PRISMATIC GLASS	-	1No.
4.	GASKET	NITRILE BUTYL RUBBER	1No.
5.	ALLEN KEY BOLT	-	4Nos.

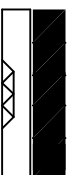
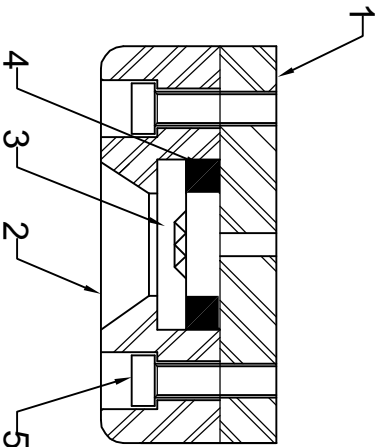
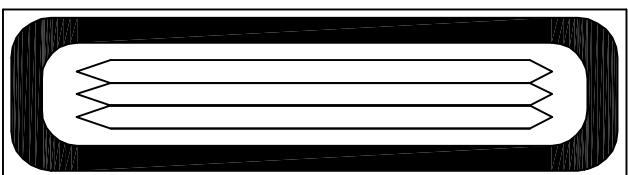
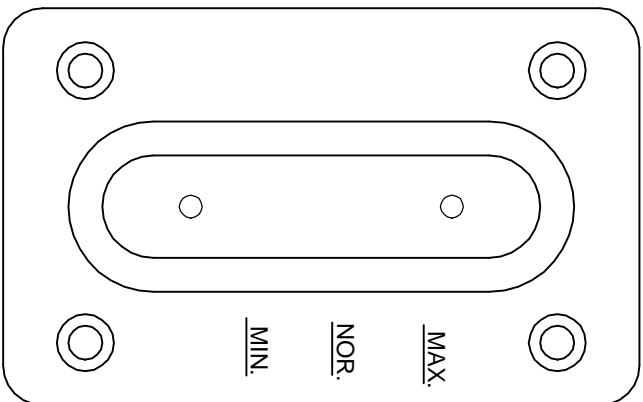

Chief Engineer
Power Systems, Planning & Design
APTransco

NOTE : DRAWING APPROVAL SUBJECT TO VALID TYPE TEST REPORTS, TO BE CHECKED DURING ACCEPTANCE TESTS.

FOR EPC CONTRACTS ONLY

VISHAL TRANSFORMERS & SWITCHGEARS (P) LTD.
RITHANI, DELHI ROAD, MEERUT U.P (INDIA)



SCALE
N.T.S.

BOM NO.

DRG. REF.
GA-013321-313

DRN.	NAME	SIGN.	DATE
CHK.	VISHESH GAURAV		
APPD.	M.P.S.		

TITLE
OIL LEVEL INDICATOR FOR 33KV CT
(CT RATIO : 1600-1200-800/1-1-1-1A)

DRAWING NO. :- OLI-065

REV.NO.	DESCRIPTION	REV. BY	APPD. BY	DATE
TOLERANCE:-	-	WEIGHT:-	-	

ALL DIMENSIONS ARE IN MM.